

2-Color Display High-Precision Digital Pressure Switch

ZSE40A(F)/ISE40A Series



RoHS

IP65

M8 connector type



Applicable fluid

Air, Non-corrosive gas, Non-flammable gas

Can copy to up to **10** switches simultaneously.

The settings of the master sensor (source of copy) can be copied to the slave sensors.

- Reducing setting labor
- Minimizing risk of mistakes in setting

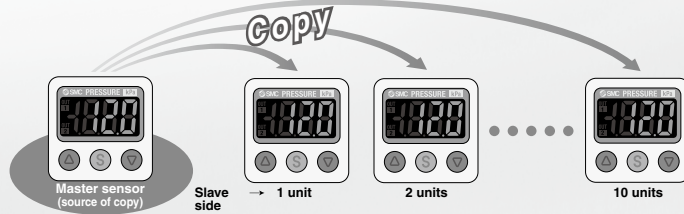

Easy handling!



Raised rubber switch buttons for easy and comfortable operation

3-step setting

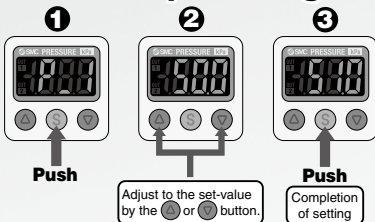

2-color display

See abnormal values at a glance.



ZSE20
ISE20
ZSE30
ISE30
ZSE40
ISE40
ZSE10
ISE10
ISE70
ZSE80
ISE80
PS
ISA3
ISA2
ISE35
PSE
IS
ISG
ZSM1

Piping Variations

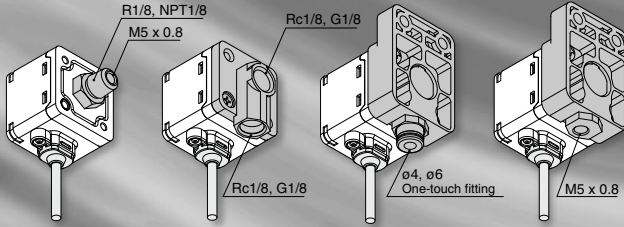

Space-saving

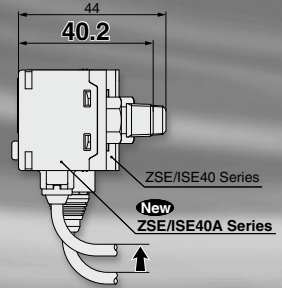

Mounting Variations

Bracket A

Bracket B

Bracket D

Direct mounting
(Wall mounting)

Panel mounting

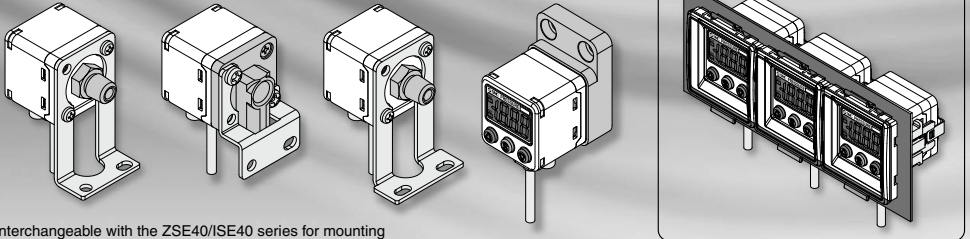

Interchangeable with the ZSE40/ISE40 series for mounting

Series

Series	ZSE40A (vacuum pressure)	ZSE40AF (compound pressure)	ISE40A (positive pressure)
Rated pressure range	0.0 to -101.3 kPa	-100.0 to 100.0 kPa	-0.100 to 1.000 MPa 1 MPa
Set pressure range	10.0 to -105.0 kPa	-105.0 to 105.0 kPa	-0.105 to 1.050 MPa
Withstand pressure	500 kPa	500 kPa	1.5 MPa
Min. unit setting	0.1 kPa	0.1 kPa	0.001 MPa
Output	<ul style="list-style-type: none"> • NPN or PNP open collector 2 outputs (with copy function) • NPN or PNP open collector 2 outputs + Analog output (voltage or current)/Auto-shift input 		
Piping	R1/8, NPT1/8 (With M5 female thread), Rc1/8, G1/8, M5 female thread ø4, ø6 One-touch fitting		

Secret code setting function.....

A function to prevent operation by anyone other than the designated operator while the keys are locked.



An optional 3-digit value is entered.

* The set-value can be checked while the keys are locked.

Power-saving function.....

The display can be turned off to save the power consumption. (Power consumption reduced by max. 20%)



The value disappears and decimal points start flashing.

Resolution conversion function.....

The flickering on the display can be eliminated.



1/1000



1/100

(Only the displayed value is changed, and there is no effect on the accuracy.)

MPa/kPa switching function.....

The indication unit for vacuum, compound pressure and positive pressure can be integrated into either MPa or kPa.



kPa Stick the label (enclosed with the product) of a desired unit seal.

2-Color Display High-Precision Digital Pressure Switch

CE c  RoHS

ZSE40A(F)/ISE40A Series

How to Order

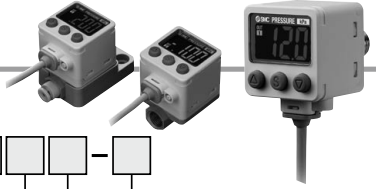

Rated pressure range
ISE40A -0.1 to 1.000 MPa

For positive pressure

ISE40A - 01 - X - M [] [] []

For vacuum/
compound pressure

ZSE40A - 01 - Y - M [] [] []

Rated pressure range
ZSE40A 0.0 to -101.3 kPa
ZSE40AF -100.0 to 100 kPa

Piping specifications

Option 2

Symbol	Calibration certificate (Note)
NII	—
K	○

(Note) All texts in both English and Japanese

Made to Order

Symbol	Specifications/Description
X501	Lead wire length 3 m
X531	M12 4-pin pre-wired connector (Lead wire length 100 mm)

(Note) Refer to page 66 for details.

Option 1	Description	Piping specifications
01	R1/8 (With M5 female thread)	R1/8, NPT1/8 M5 x 0.8
N01	NPT1/8 (With M5 female thread)	
W1	Rc1/8	Rc1/8, G1/8
WF1*	G1/8*1	Rc1/8, G1/8
M5*	M5 x 0.8 (Female thread)	M5 x 0.8
C4*	ø4 One-touch fitting	
C6*	ø6 One-touch fitting	ø4, ø6 One-touch fitting

* Made to Order
 * Conforming to ISO228-1.

Combination of piping specifications with option 1 and part numbers of options

Option 1		Piping							
Description	Symbol	Part no.	01	N01	W1	WF1	M5	C4	C6
Bracket A	A	ZS-24-A	○	○	○	○	×	×	×
Bracket B	B	ZS-24-B	×	×	○	○	×	×	×
Bracket D	D	ZS-24-D	○	○	○	○	×	×	×
Panel mount adapter	E	ZS-35-C	○	○	×	×	×	×	×
Panel mount adapter + Front protective cover	F	ZS-35-F	○	○	×	×	×	×	×
		ZS-35-G	×	×	○	○	○	○	○

Output specifications

X	NPN open collector 2 outputs (with copy function)
Y	PNP open collector 2 outputs (with copy function)
R	NPN open collector 2 outputs + Analog voltage/Auto-shift switching
T	PNP open collector 2 outputs + Analog voltage/Auto-shift switching
S	NPN open collector 2 outputs + Analog current/Auto-shift switching
V	PNP open collector 2 outputs + Analog current/Auto-shift switching

When optional parts are required separately, use the following part numbers to place an order.

Options 1/Part No.

Part no.	Option
ZS-24-A	Bracket A Mounting screw M3 x 5L, M4 x 5L (2 pcs. for each)
ZS-24-B	Bracket B Mounting screw M4 x 5L (2 pcs.)
ZS-24-D	Bracket D Mounting screw M3 x 5L, M4 x 5L (2 pcs. for each)
ZS-35-C	Panel mount adapter (Piping: For 01/N01)
ZS-35-D	Panel mount adapter (Piping: For W1/WF1/M5/C4/C6)
ZS-35-F	Panel mount adapter + Front protective cover (Piping: For 01/N01)
ZS-35-G	Panel mount adapter + Front protective cover (Piping: For W1/WF1/M5/C4/C6)

Unit specifications

NII	With unit switching function (Note 1)
M	Fixed SI unit (Note 2)
P	With unit switching function (Note 1) (Initial value psi)

Note 1) Under the New Measurement Law, sales of switches with the unit switching function are not allowed for use in Japan.
 Note 2) Unit: kPa, MPa

Option 1*

Option 1*	Description
NII	None
A	Bracket A
B	Bracket B
D	Bracket D
E	Panel mount adapter 01/N01
F	Panel mount adapter + Front protective cover 01/N01

* Some options are unavailable depending on the piping specifications. Refer to "Combination of piping specifications with option 1 and part numbers of options".

- ZSE20
- ISE20
- ZSE30
- ISE30
- ZSE40
- ISE40
- ZSE10
- ISE10
- ISE70
- ZSE80
- ISE80
- PS
- ISA3
- ISA2
- ISE35
- PSE
- IS
- ISG
- ZSM1

ZSE40A(F)/ISE40A Series

How to Order [For M8 (3 pins) connector]



Rated pressure range

ISE40A	-0.1 to 1.000 MPa
---------------	-------------------

For positive pressure

ISE40A - 01 - N - M L [] []

For vacuum

ZSE40A - 01 - N - M L [] []

Rated pressure range

ZSE40A	0.0 to -101.3 kPa
---------------	-------------------

Piping specifications

01	R1/8 (M5 female threaded)
N01	NPT1/8 (M5 female threaded)

Output specifications

N	NPN open collector 1 output
P	PNP open collector 1 output

Unit specifications

Nil	With unit display switching function <small>Note 1)</small>
M	Fixed SI unit <small>Note 2)</small>
P	With unit switching function (Initial value psi) <small>Note 1)</small>

Note 1) Under the New Measurement Law, Unit specifications sales of switches with the unit switching function are not allowed for use in Japan.



Note 2) Unit kPa, MPa

Option 2

Symbol	Operation manual <small>Note)</small>	Calibration certificate <small>Note)</small>
Nil	●	—
Y	—	—
K	●	●
T	—	●

Note) All texts in both English and Japanese

Option 1

Nil	None
A	Bracket A 
D	Bracket D 

M8 connector type*

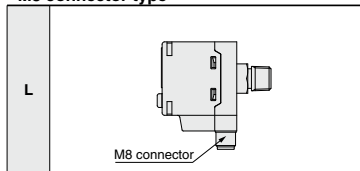

* No lead wires are connected.

Options 1/Part No.

When optional parts are required separately, use the following part numbers to place an order.

Part no.	Option
ZS-24-A	Bracket A Mounting screw M3 x 5L, M4 x 5L (2 pcs. for each)
ZS-24-D	Bracket D Mounting screw M3 x 5L, M4 x 5L (2 pcs. for each)

2-Color Display High-Precision Digital Pressure Switch **ZSE40A(F)/ISE40A Series**

Refer to pages 11 and 12 for Pressure Switch Precautions. For details about the Specific Product Precautions, refer to the Operation Manual on the SMC website, <http://www.smcworld.com>

Specifications

Model		ZSE40A (vacuum pressure)	ZSE40AF (compound pressure)	ISE40A (positive pressure)	
Rated pressure range		0.0 to -101.3 kPa	-100.0 to 100.0 kPa	-0.100 to 1.000 MPa	
Display/Set pressure range		10.0 to -105.0 kPa	-105.0 to 105.0 kPa	-0.105 to 1.050 MPa	
Withstand pressure		500 kPa	500 kPa	1.5 MPa	
Display/Minimum unit setting		0.1 kPa	0.1 kPa	0.001 MPa	
Applicable fluid		Air, Non-corrosive gas, Non-flammable gas			
Power supply voltage		12 to 24 VDC $\pm 10\%$, Ripple (p-p) 10% or less (with power supply polarity protection)			
Current consumption		45 mA or less			
Switch output		NPN or PNP open collector 1 output or 2 outputs			
Maximum load current		80 mA			
Maximum applied voltage		28 V (at NPN output)			
Residual voltage		1 V or less			
Response time		2.5 ms (with anti-chattering function: 20, 100, 500, 1000, 2000 ms)			
Short circuit protection		Yes			
Repeat accuracy		$\pm 0.2\%$ F.S. ± 1 digit			
Hysteresis	Hysteresis mode	Variable (0 or above) ^{Note 1)}			
	Window comparator mode				
Analog output	^{Note 2)} Voltage output	Output voltage (Rated pressure range)	1 to 5 V $\pm 2.5\%$ F.S.	0.6 to 5 V $\pm 2.5\%$ F.S.	
		Linearity	$\pm 1\%$ F.S.		
		Output impedance	Approx. 1 k Ω		
	^{Note 3)} Current output	Output current (Rated pressure range)	4 to 20 mA $\pm 2.5\%$ F.S.	2.4 to 20 mA $\pm 2.5\%$ F.S.	
		Linearity	$\pm 1\%$ F.S.		
		Load impedance	Maximum load impedance: 300 Ω (Power supply voltage 12 V) 600 Ω (Power supply voltage 24 V) Minimum load impedance: 50 Ω		
Auto-shift input		Non-voltage input (Reed or Solid state), Low level: 0.4 V or less, 5 ms or longer input			
Display		3 1/2-digit, 7-segment, 2-color LCD (Red/Green)			
Display accuracy		$\pm 2\%$ F.S. ± 1 digit (Ambient temperature of 25 $\pm 3^\circ\text{C}$)			
Indicator light		Lights up when output is turned ON. OUT1, OUT2: Orange			
Environment	Enclosure	IP65			
	Operating temperature range ^{Note 4)}	Operating: -5 to 50°C , Stored: -10 to 60°C (No freezing or condensation)			
	Operating humidity range	Operating/Stored: 35 to 85% RH (No condensation)			
	Withstand voltage	1000 VAC for 1 minute between terminals and housing			
	Insulation resistance	50 M Ω or more (500 VDC measured via megohmmeter) between terminals and housing			
Temperature characteristics		$\pm 2\%$ F.S. (25°C reference)			
Lead wire		Oilproof heavy-duty vinyl cable 5 cores $\phi 3.5$, 2 m Conductor area: 0.15 mm ² (AWG26) Insulator O.D.: 0.95 mm			
Standards		CE, UL/CSA (E216656), RoHS			

Note 1) If the applied pressure fluctuates around the set-value, the hysteresis must be set to a value more than the fluctuating width, otherwise chattering will occur.

Note 2) When the analog voltage output is selected, the analog current output cannot be selected.

Note 3) When the analog current output is selected, the analog voltage output cannot be selected.

Note 4) UL temperature rating: The maximum ambient temperature is 50°C .

Piping Specifications

Part no.		O1	N01	W1	WF1	M5	C4	C6
Port size		R1/8 (With M5 female thread)	NPT1/8 (With M5 female thread)	Rc1/8	G1/8	M5 x 0.8 female thread	$\phi 4$ One-touch fitting	$\phi 6$ One-touch fitting
Material of parts in contact with fluid	Sensor pressure receiving area	Silicon						
	Piping port	C3602 (Electroless nickel plating) O-ring: HNBR			ZDC2 O-ring: HNBR		ZDC2, POM, Stainless steel 304, C3604 (Electroless nickel plating) O-ring: HNBR, NBR	
Weight		78 g	79 g	97 g	104 g	101 g		
M8 connector		45 g	46 g	-		-		

ZSE40A(F)/ISE40A Series

Set Pressure Range and Rated Pressure Range



Set the pressure within the rated pressure range.

The set pressure range is the range of pressure that is possible in setting.

The rated pressure range is the range of pressure that satisfies the specifications (accuracy, linearity, etc.) on the switch.

Although it is possible to set a value outside the rated pressure range, the specifications will not be guaranteed even if the value stays within the set pressure range.

Switch		Pressure range				
		-100 kPa	0	100 kPa	500 kPa	1 MPa
For vacuum pressure	ZSE40A	-101.3 kPa	0	100 kPa	500 kPa	1 MPa
		-105 kPa	10 kPa			
For compound pressure	ZSE40AF	-100 kPa	100 kPa	100 kPa	500 kPa	1 MPa
		-105 kPa	105 kPa			
For positive pressure	ISE40A	-100 kPa	100 kPa	100 kPa	500 kPa	1 MPa
		-105 kPa	105 kPa			1.05 MPa
		(-0.105 MPa)				

 Rated pressure range of switch
 Set pressure range of switch

Analog Output

Voltage output

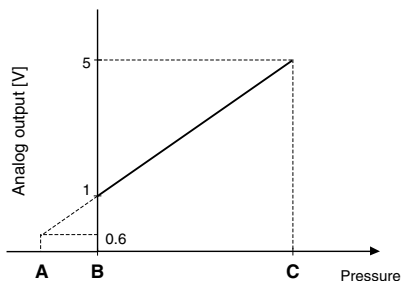

Current output

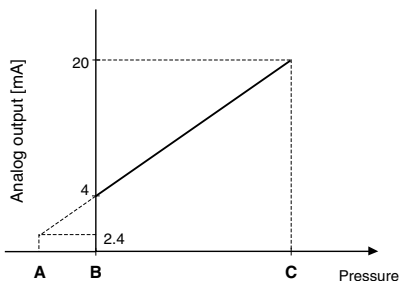

Range	Rated pressure range	A	B	C
For vacuum pressure	0.0 to -101.3 kPa	10.1 kPa	0	-101.3 kPa
For compound pressure	-100.0 to 100.0 kPa	—	-100.0 kPa	100.0 kPa
For positive pressure	-0.100 to 1.000 MPa	-0.100 MPa	0	1.000 MPa

Internal Circuits and Wiring Examples

**-X
NPN (2 outputs) + Copy function**

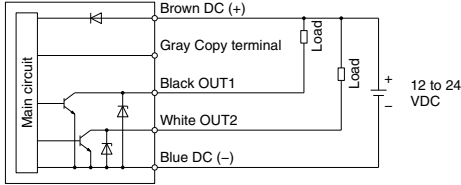

**-Y
PNP (2 outputs) + Copy function**

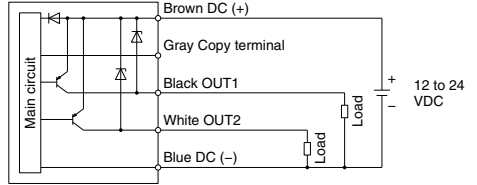

**-R/-S
-R: NPN (2 outputs) + Analog voltage output
-S: NPN (2 outputs) + Analog current output**

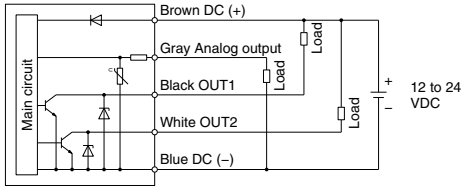

**-R/-S
NPN (2 outputs) + Auto-shift input**

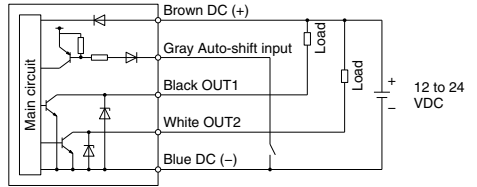

**-T/-V
-T: PNP (2 outputs) + Analog voltage output
-V: PNP (2 outputs) + Analog current output**

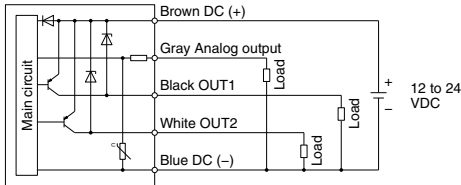

**-T/-V
PNP (2 outputs) + Auto-shift input**

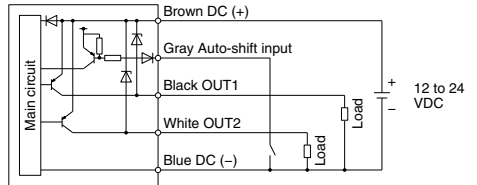

For M8 connector, 3 pins

**-N
NPN (1 output)**

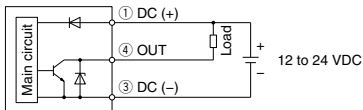

**-P
PNP (1 output)**

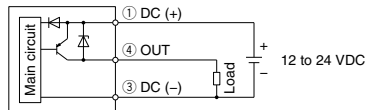

ZSE20

ZSE30

ZSE40

ISE10

ISE70

ZSE80

ISE80

PS

ISA3

ISA2

ISE35

PSE

IS

ISG

ZSM1

ZSE40A(F)/ISE40A Series

Dimensions (For details about lead wires, refer to the product specifications.)

ZSE40A(F)/ISE40A-01

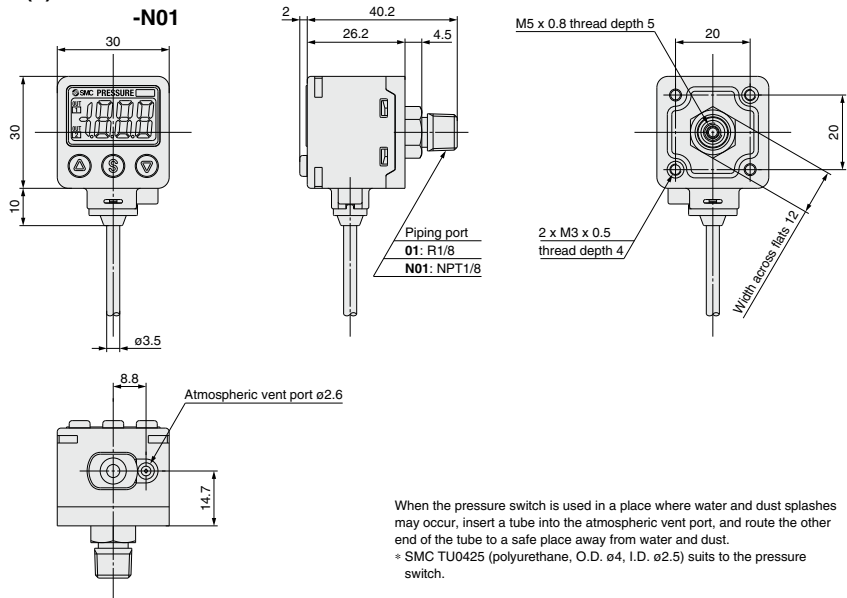

ZSE40A(F)/ISE40A-W1

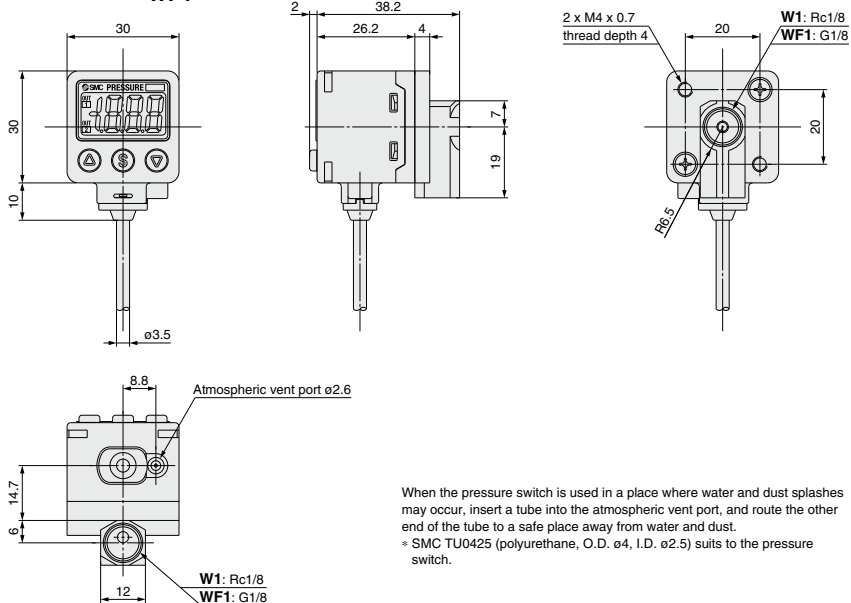

2-Color Display High-Precision Digital Pressure Switch **ZSE40A(F)/ISE40A Series**

Dimensions/For M8 (3-pin) connector

ZSE40A/ISE40A-01-□-□L
-N01-□-□L

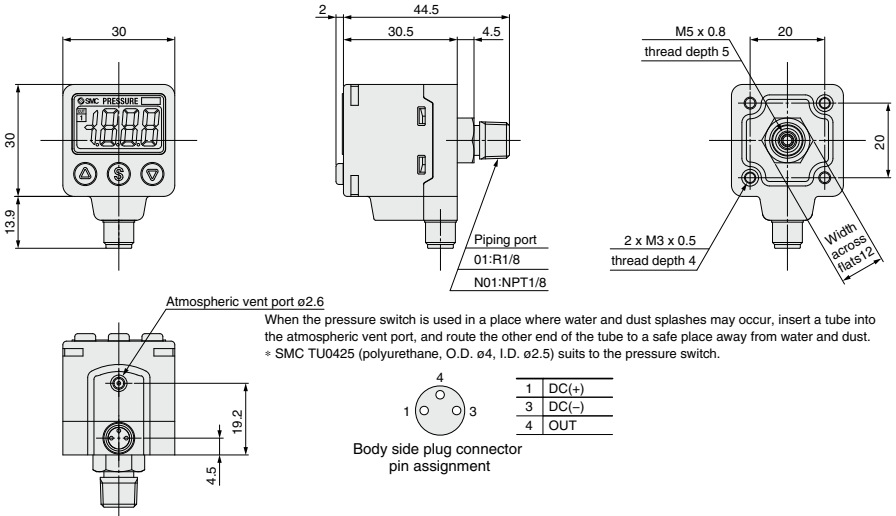

M8 (3-pin) cable with connector

V100-49-1-□

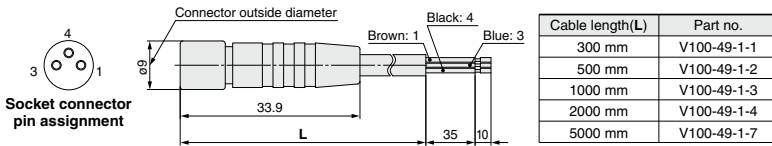

PCA-1557772

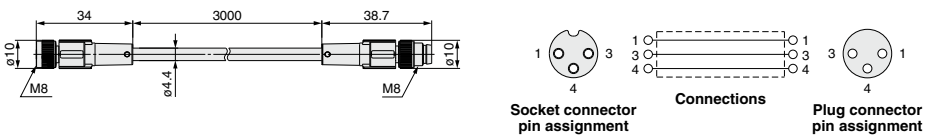

ZSE20
ISE20
ZSE30
ISE30
ZSE40
ISE40
ZSE10
ISE10
ISE70
ZSE80
ISE80
PS
ISA3
ISA2
ISE35
PSE
IS
ISG
ZSM1

ZSE40A(F)/ISE40A Series

Dimensions (For details about lead wires, refer to the product specifications.)

ZSE40A(F)/ISE40A-C4 -C6

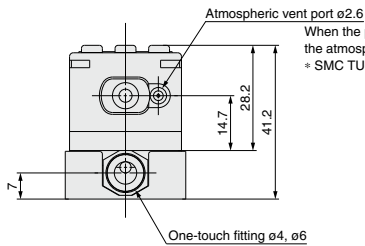
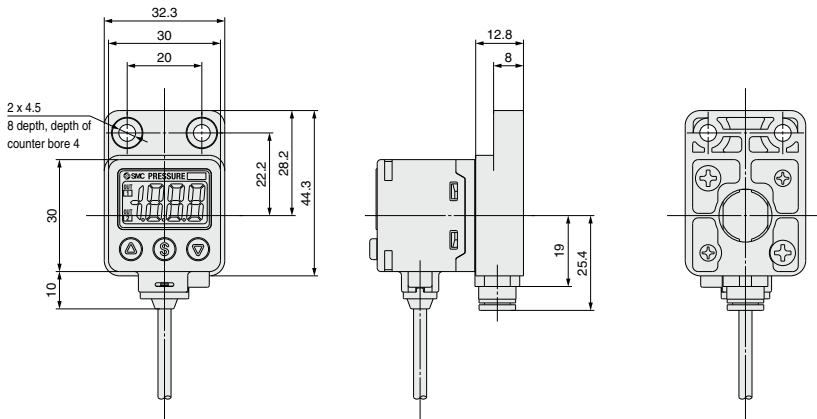

When the pressure switch is used in a place where water and dust splashes may occur, insert a tube into the atmospheric vent port, and route the other end of the tube to a safe place away from water and dust.
* SMC TU0425 (polyurethane, O.D. ø4, I.D. ø2.5) suits to the pressure switch.

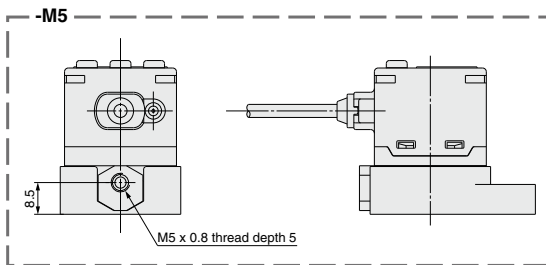

2-Color Display High-Precision Digital Pressure Switch **ZSE40A(F)/ISE40A Series**

Dimensions (For details about lead wires, refer to the product specifications.)

ZSE40A(F)/ISE40A-01-□-□A□

-N01-□-□A□

With bracket A

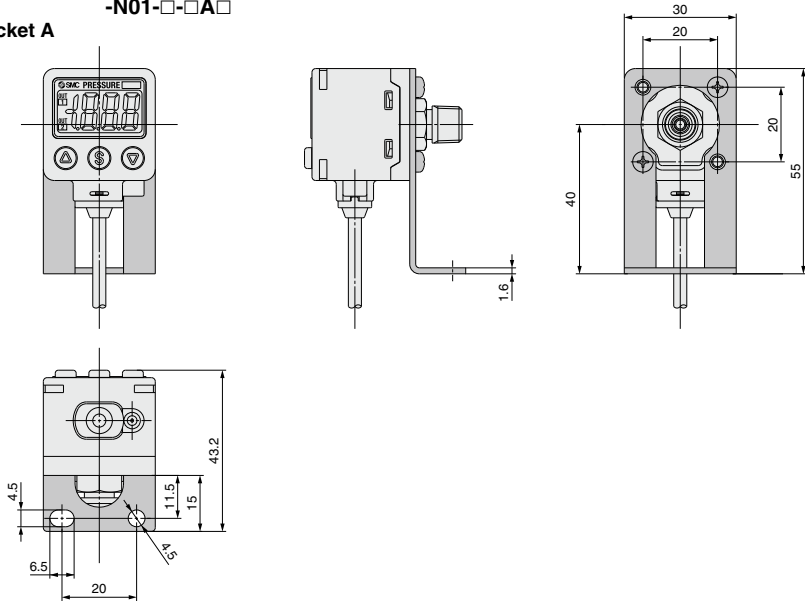

For M8 (3-pin) connector

ZSE40A/ISE40A-01-□-□LA

-N01-□-□LA

With bracket A

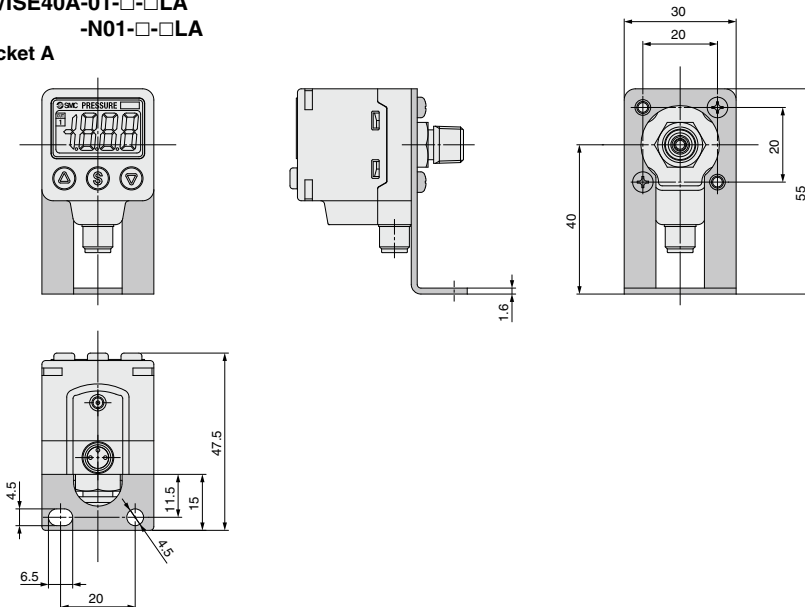

ZSE20
ISE20

ZSE30
ISE30

**ZSE40
ISE40**

ZSE10
ISE10

ISE70

ZSE80
ISE80

PS

ISA3

ISA2

ISE35

PSE

IS

ISG

ZSM1

ZSE40A(F)/ISE40A Series

Dimensions (For details about lead wires, refer to the product specifications.)

ZSE40A(F)/ISE40A-01-□-□D□

-N01-□-□D□

With bracket D

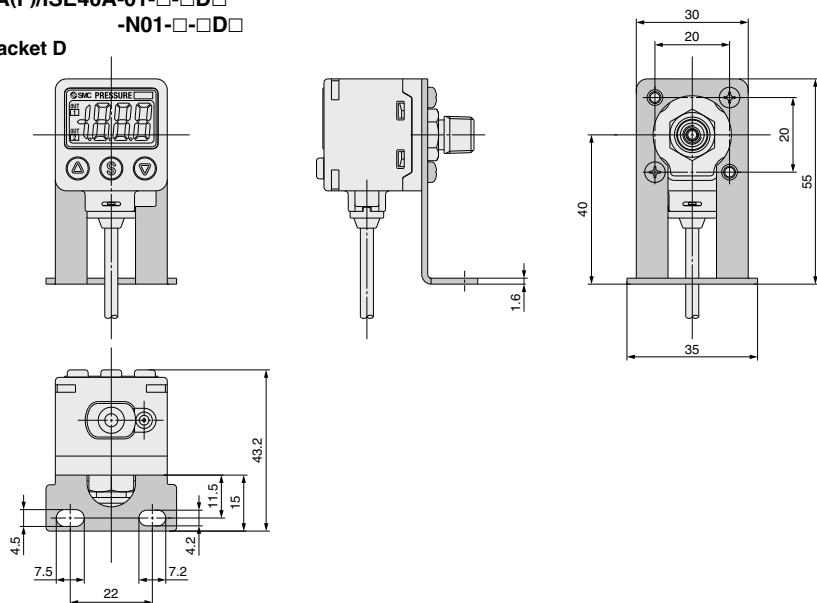

For M8 (3-pin) connector

ZSE40A/ISE40A-01-□-□LD

-N01-□-□LD

With bracket D

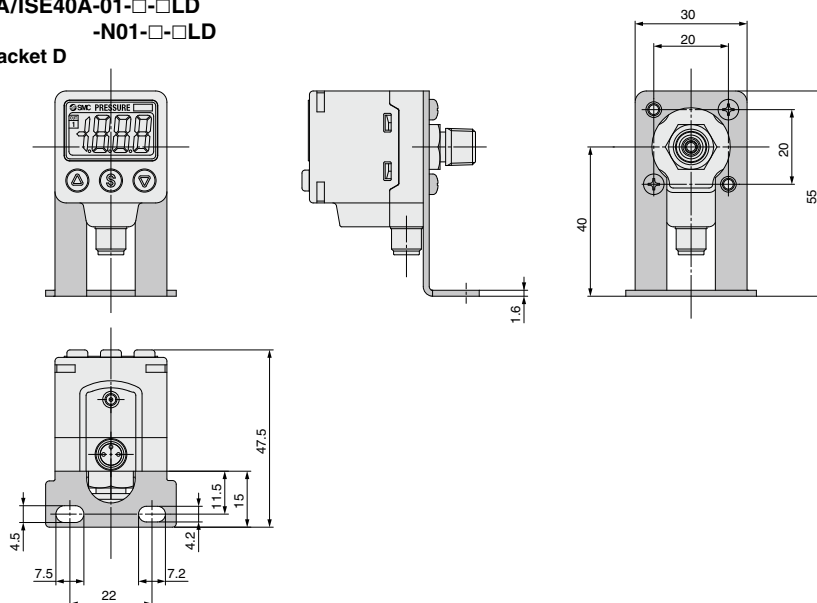

2-Color Display High-Precision Digital Pressure Switch **ZSE40A(F)/ISE40A Series**

Dimensions (For details about lead wires, refer to the product specifications.)

ZSE40A(F)/ISE40A-W1-□-□A□
-WF1-□-□A□

With bracket A

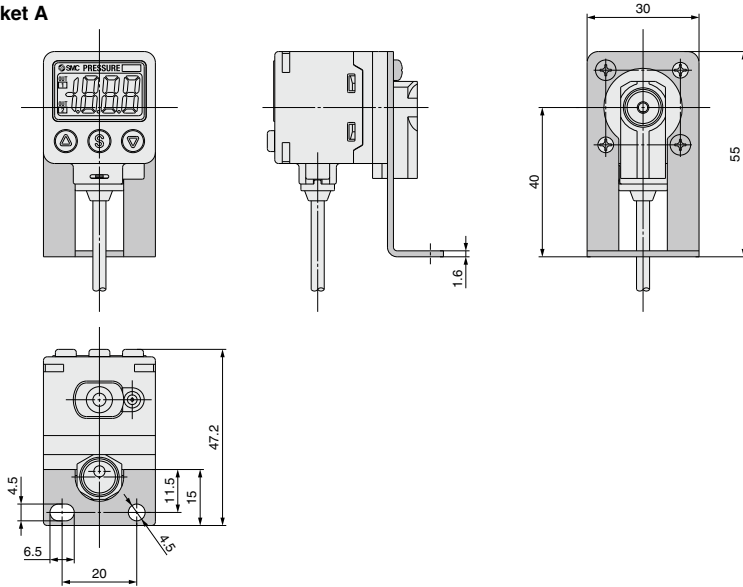

ZSE40A(F)/ISE40A-W1-□-□B□
-WF1-□-□B□

With bracket B

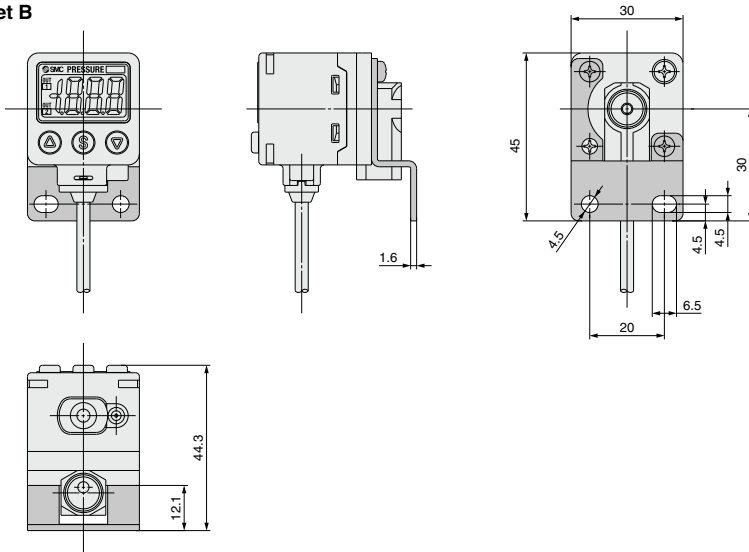

ZSE20
ISE20
ZSE30
ISE30
ZSE40
ISE40
ZSE10
ISE10
ISE70
ZSE80
ISE80
PS
ISA3
ISA2
ISE35
PSE
IS
ISG
ZSM1

ZSE40A(F)/ISE40A Series

Dimensions (For details about lead wires, refer to the product specifications.)

ZSE40A(F)/ISE40A-W1-□-□D□
-WF1-□-□D□

With bracket D

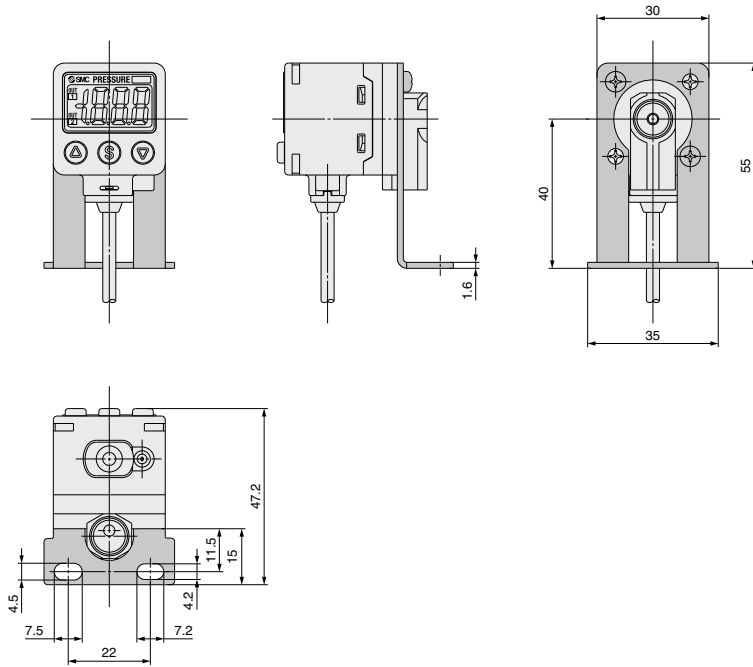

2-Color Display High-Precision Digital Pressure Switch **ZSE40A(F)/ISE40A Series**

Dimensions (For details about lead wires, refer to the product specifications.)

ZSE40A(F)/ISE40A-01-□-□E□
-N01-□-□E□

Panel mount adapter

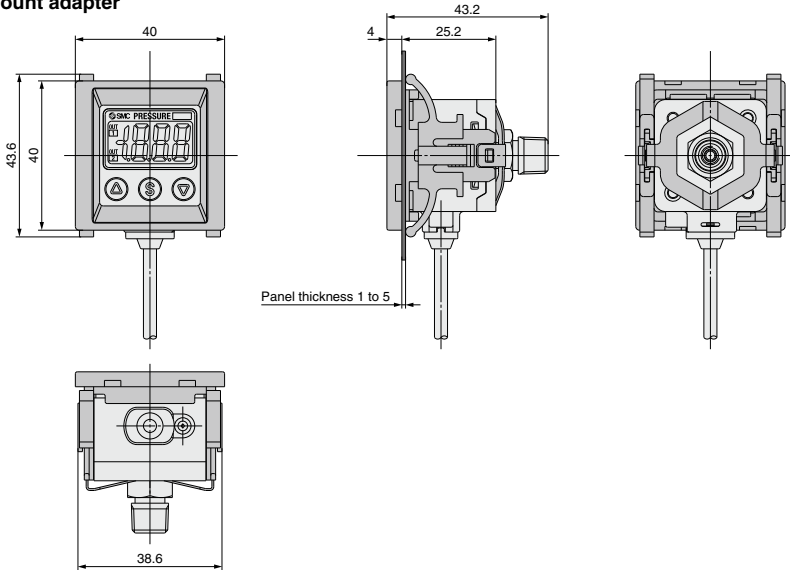

ZSE40A(F)/ISE40A-01-□-□F□
-N01-□-□F□

Panel mount adapter + Front protective cover

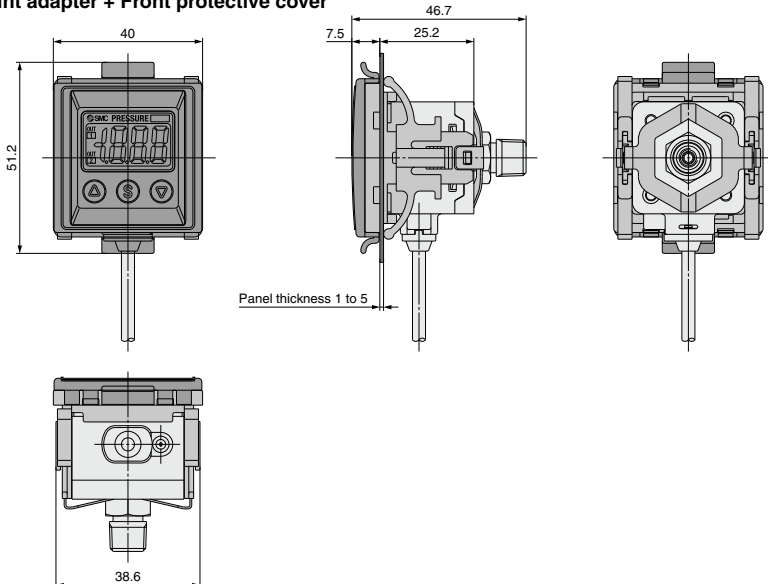

ZSE20
ISE20
ZSE30
ISE30
ZSE40
ISE40
ZSE70
ISE70
ZSE80
ISE80
PS
ISA3
ISA2
ISE35
PSE
IS
ISG
ZSM1

ZSE40A(F)/ISE40A Series

Dimensions (For details about lead wires, refer to the product specifications.)

ZSE40A(F)/ISE40A-W1-□-□E□

-WF1-□-□E□

Panel mount adapter

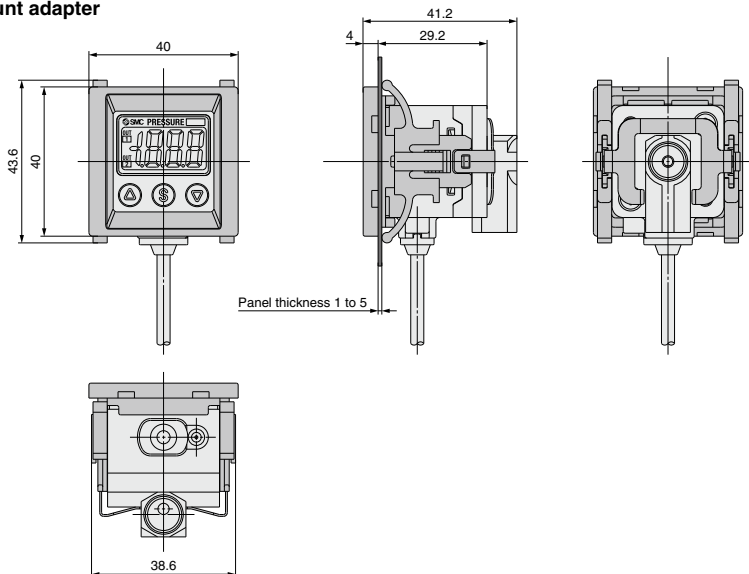

ZSE40A(F)/ISE40A-W1-□-□F□

-WF1-□-□F□

Panel mount adapter + Front protective cover

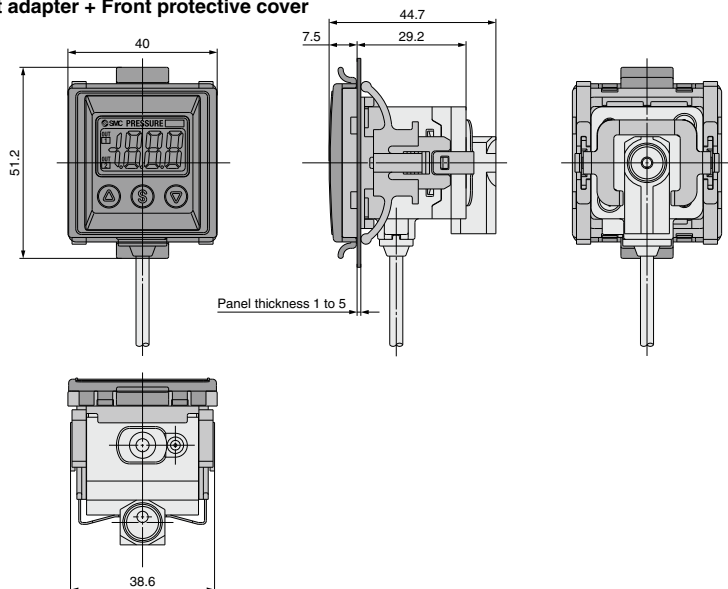

2-Color Display High-Precision Digital Pressure Switch **ZSE40A(F)/ISE40A Series**

Dimensions (For details about lead wires, refer to the product specifications.)

**ZSE40A(F)/ISE40A-C4-□E□
-C6-□E□**

Panel mount adapter

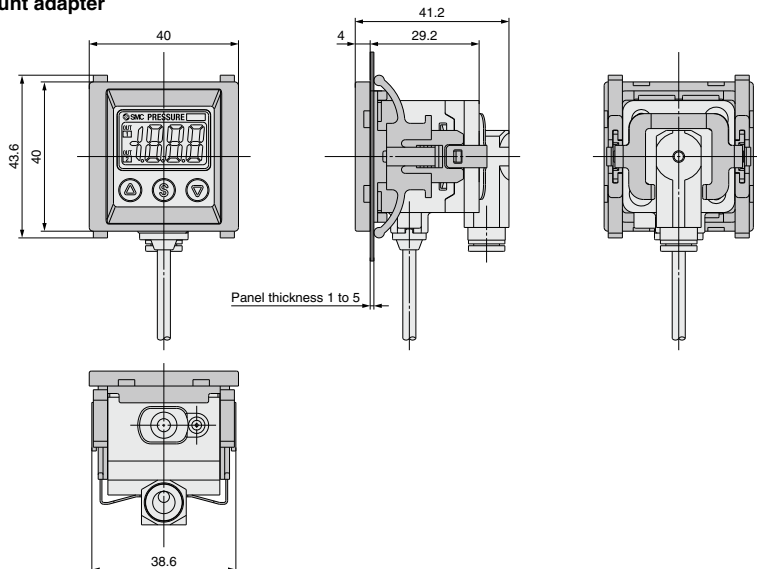

**ZSE40A(F)/ISE40A-C4-□F□
-C6-□F□**

Panel mount adapter + Front protective cover

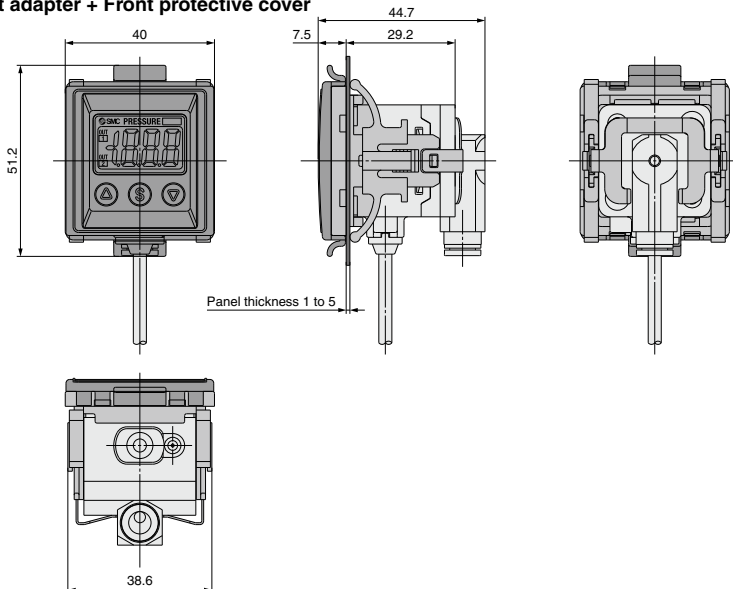

ZSE20
ISE20
ZSE30
ISE30
ZSE40
ISE40
ZSE10
ISE10
ISE70
ZSE80
ISE80
PS
ISA3
ISA2
ISE35
PSE
IS
ISG
ZSM1

ZSE40A(F)/ISE40A Series

Dimensions

Panel fitting dimensions

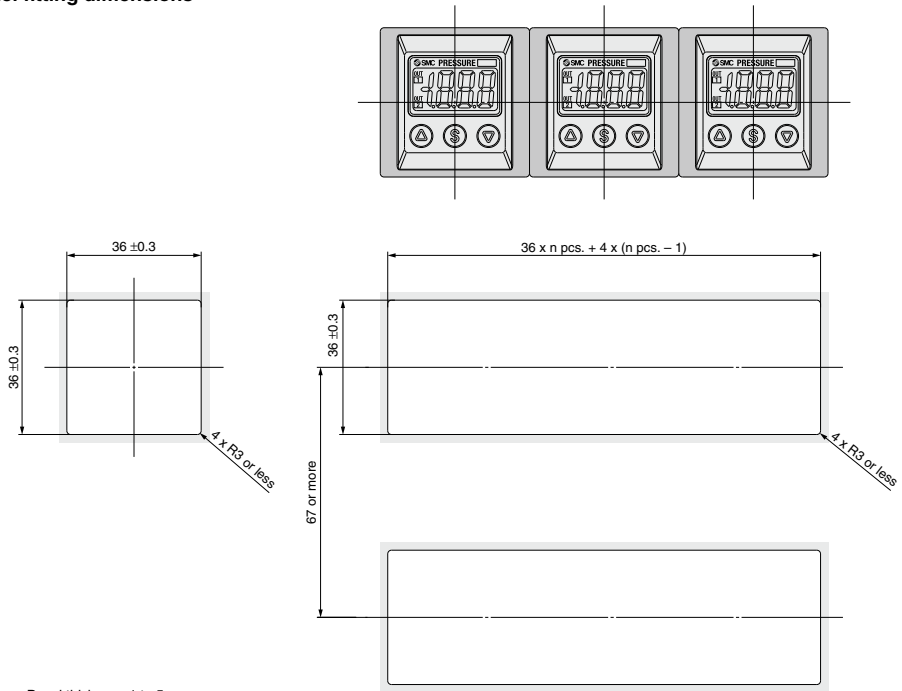

Note) This is the minimum value for the piping method O1 or N01.

Take the piping material and tubing into account for design. When the corner is to have radius, it must be R3 or less.

The F□ in () shows the function code number. Refer to the Operation Manual for the details of operation procedures and function codes.

Function Details

A Copy function (F97)

The settings of the master sensor can be copied to the slave sensors, reducing setting labor and minimizing risk of mistakes in setting.

Can copy to up to 10 switches simultaneously.
(Maximum transmission distance 4 m)

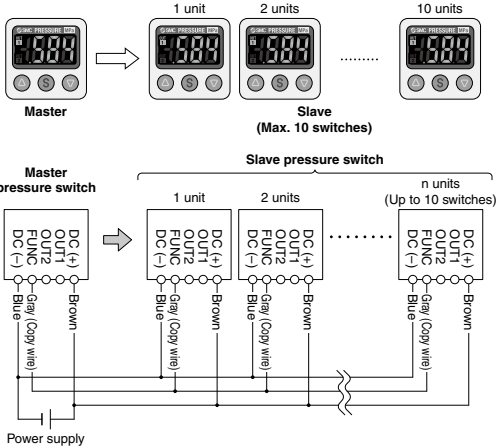

- 1) Wire as shown in the left figure.
- 2) Select the slave switch which is to be the master, and change it into a master using the buttons. (In the default setting, all switches are set as slaves.)
- 3) Press the  button of the master switch to start copying.

B Auto-preset function (F4)

Auto-preset function, when selected in the initial setting, calculates and stores the set-value from the measured pressure. The optimum set-value is determined automatically by repeating vacuum and break with the target workpiece several times.

Suction Verification

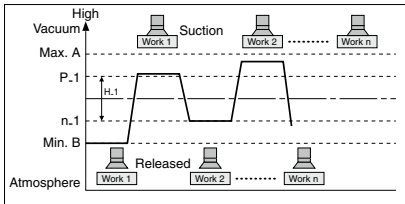

Formula for Obtaining the Set-Value

P ₁ or P ₂	H ₁ or H ₂
$P_{1} (P_{2}) = A - (A-B)/4$	$H_{1} (H_{2}) = (A-B) / 2$
$n_{1} (n_{2}) = B + (A-B)/4$	

C Display calibration function (F6)

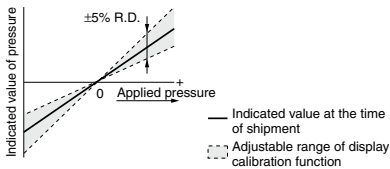

Fine adjustment of the indicated value of the pressure sensor can be made within the range of $\pm 5\%$ of the read value. (The scattering of the indicated value can be eliminated.)



Note) When the display calibration function is used, the set pressure value may change ± 1 digit.

D Peak/Bottom value indication

This function constantly detects and updates the maximum (minimum) value and allows to hold the maximum (minimum) pressure value.

When the   buttons are simultaneously pressed for 1 second or longer, while "holding", the hold value will be reset.

E Keylock function

Prevents operation errors such as accidentally changing setting values.

F Zero-clear function

This function clears and resets the zero value on the display of measured pressure.

For the pressure switch with analog output, the analog output shifts according to the indication. The indicated value can be adjusted within $\pm 7\%$ F.S. of the pressure when ex-factory. (ZSE40AF (for compound pressure) $\pm 3.5\%$ F.S.)

ZSE20
ISE20
ZSE30
ISE30
ZSE40
ISE40
ZSE10
ISE10
ISE70
ZSE80
ISE80
PS
ISA3
ISA2
ISE35
PSE
IS
ISG
ZSM1

ZSE40A(F)/ISE40A Series

Function Details

G Error indication function

Error name	Error code	Description	Action
Overcurrent error	Er1	Load current of 80 mA or more is applied to the switch output (OUT1).	Eliminate the cause of the over current by turning off the power supply, and then turn on it again.
	Er2	Load current of 80 mA or more is applied to the switch output (OUT2).	
Residual pressure error	Er3	During zero-clear operation, pressure over $\pm 7\%$ F.S. is applied. (ZSE40AF (compound) $\pm 3.5\%$ F.S.) After 1 second, the mode will reset to measurement mode. $\pm 1\%$ F.S. of the zero-clear range varies between individual products.	Perform zero-clear operation again after restoring the applied pressure to an atmospheric pressure condition.
Applied pressure error	HHH	Supply pressure exceeds the maximum set pressure.	Reset applied pressure to a level within the set pressure range.
	LLL	Supply pressure is below the minimum set pressure.	
Auto-shift error	Or	The value measured at the time of auto-shift input is outside the set pressure range. * After displaying the error code for about 1 second, the switch returns to the measuring mode.	The controller does not respond to the auto-shift signal. Check the equipment and machinery for this point.
System error	Er0	Internal data error	Turn off the power supply and then turn on it again. If the failure cannot be solved, please contact SMC for investigation.
	Er4		
	Er6		
	Er7		
	Er8		
	Er9		

If the failure cannot be solved after the above instructions are performed, please contact SMC for investigation.

H Anti-chattering function (F3)

A large bore cylinder or ejector consumes a large volume of air in operation and may experience a temporary drop in the supply pressure. This function prevents detection of such temporary drops in the supply pressure as an error.

Available response time settings
20 ms, 100 ms, 500 ms, 1000 ms, 2000 ms

<Principle>

This function averages pressure values measured during the response time set by the user and then compares the average pressure value with the pressure set point value to output the result on the switch.

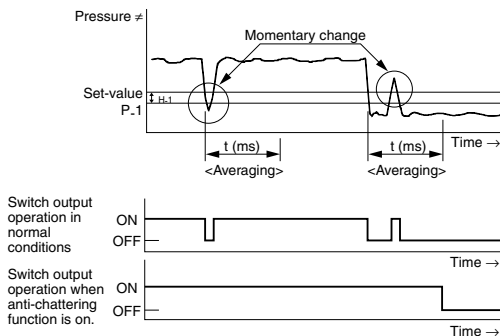

I Display unit switching function (F0)

Display units can be switched with this function.

Display unit	Pa		GF	bRr	P5 i	inH	mmH
	kPa	MPa*	kgf/cm ²	bar	psi	inHg	mmHg
Minimum unit setting	0.1	0.001	0.001	0.001	0.01	0.1	1
ZSE40A (vacuum pressure)	0.1	0.001	0.001	0.001	0.02	0.1	1
ZSE40AF (compound pressure)	0.1	0.001	0.001	0.001	0.02	0.1	1
ISE40A (positive pressure)	1	0.001	0.01	0.01	0.1		

* The ZSE40A (vacuum pressure) and ZSE40AF (compound pressure) will have different setting and display resolution when the unit is set to MPa.

The **F** in () shows the function code number. Refer to the Operation Manual for the details of operation procedures and function codes.

J Power-saving mode (F80)

Power-saving mode can be selected. It shifts to the power-saving mode without button operation for 30 seconds. It is set to the normal mode (Power-saving mode is OFF.) when ex-factory. (Decimal points and operation indicator light (only when the switch output is turned ON.) blink in the power-saving mode.)

K Setting of secret code (F81)

Users can select whether a secret code must be entered to release key lock. At the time of shipment from the factory, it is set such that the secret code is not required.

L Auto-shift function (F5)

When there are large fluctuations in the supply pressure, the switch may fail to operate correctly. The auto-shift function compensates such supply pressure fluctuations. It measures the pressure at the time of auto-shift signal input and uses it as the reference pressure to correct the set-value on the switch.

Set-value correction by auto-shift function

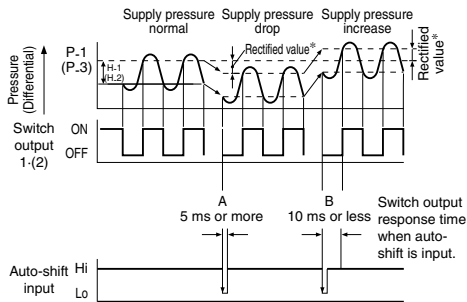

* Rectified value

When the auto-shift is selected, "000" will be displayed for about 1 second, and the pressure value at that point will be saved as a rectified value "C.5". Based on the saved rectified values, the set-value ^{Note)} of "P_1", "H_1", "P_2", and "H_2" will likewise be rectified.

Note) When an output is reversed, "n_1", "H_1", "n_2", and "H_2" will be rectified.

Settable Range for Auto-Shift Input

	Set pressure range	Settable range
Compound pressure	-105.0 to 105.0 kPa	-210 to 210 kPa
Vacuum pressure	10.0 to -105.0 kPa	115.0 to -115.0 kPa
Positive pressure	-0.105 to 1.050 MPa	-1.155 to 1.155 MPa

Auto-shift zero

The basic function of auto-shift zero is the same as the function for auto-shift. Also, it corrects values on the display, based on a pressure value of "0", when the auto-shift is selected.

Connection example of auto-shift function

Output specifications: -R/-S PNP (2 outputs) + Auto-shift input

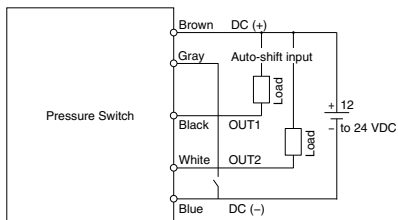

Output specifications: -T/-V PNP (2 outputs) + Auto-shift input

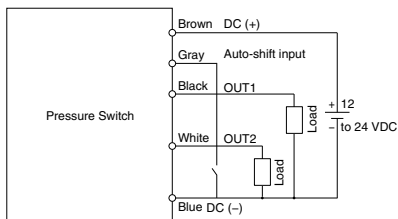

ZSE20
ISE20
ZSE30
ISE30
ZSE40
ISE40
ZSE10
ISE10
ISE70
ZSE80
ISE80
PS
ISA3
ISA2
ISE35
PSE
IS
ISG
ZSM1

ZSE40A(F)/ISE40A Series Made to Order

Please contact SMC for detailed dimensions, specifications and lead times.



1 Lead Wire Length 3 m

Symbol
-X501

It has a lead wire extended to 3 meters.

How to Order

* Refer to "How to Order" on page 47 for standard specifications.

ZSE40A(F)/ISE40A - □ - □ - □ - X501

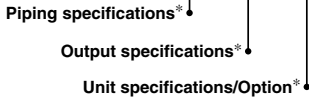

2 M12 4-pin Pre-wired Connector (Lead wire length 100 mm)

Symbol
-X531

How to Order

* Refer to "How to Order" on page 47 for standard specifications.

ZSE40A(F)/ISE40A - □ - □ - □ - X531

