

Isolated RS485 Interface With Handshake

Functional Diagram

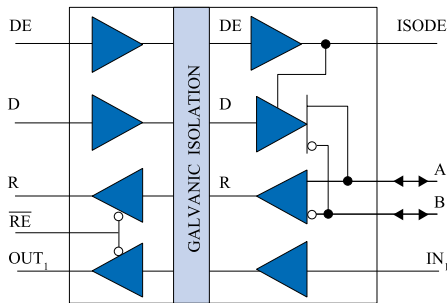

Features

- 2500 V_{RMS} Isolation (1 min)
- 25 ns Maximum Propagation Delay
- 35 Mbaud Data Rate
- 1 ns Pulse Skew (typ.)
- Designed for Multi-point Transmission on Long Bus Lines in Noisy Environments
- ±60 mA Driver Output Capability
- Thermal Shutdown Protection
- Meets or Exceeds ANSI RS-485 and ISO 8482:1987 (E)
- -40°C to +85°C Temperature Range
- 16 Pin SOIC Package
- PROFIBUS International Component Recognition
- UL1577 Approval (pending)
- IEC 61010-1 Approval (pending)

Function Table

V _{ID} (A-B)	DE	\overline{RE}	ISODE	R	D	MODE
≥ 0.2V	L	L	L	H	X	Receive
≤ -0.2V	L	L	L	L	X	Receive
-7 < V _{ID} < 12	X	H	X	Z	X	Receive/Drive
≥ 1.5	H	L	H	H	H	Drive
≤ -1.5	H	L	H	L	L	Drive
Open	L	L	L	H	X	Receive

RE ₁	IN ₁	OUT ₁
L	L	L
L	H	H
H	X	Z

H= High Level
L= Low Level
X= Irrelevant
Z= High Impedance

Applications

- PROFIBUS/RS485
- RS-485 Systems
- Multiple Data Point Transmission

Description

The IL485W is a galvanically isolated, high speed differential bus transceiver, designed for bidirectional data communication on balanced transmission lines. The IL485W uses patented* IsoLoop® technology and is the first isolated RS-485 interface available in a standard 16 pin SOIC package, which meets the ANSI Standards EIA/TIA-422-B and RS485.

The IL485W has current limiting and thermal shutdown features to protect against output short circuits and bus contention situations where these may cause excessive power dissipation.

With a 1 nsec pulse skew and 16 nsec propagation delay, the IL485W is ideal for PROFIBUS applications. Use of DE/ISODE and IN₁/OUT₁ allows the IL485W to perform the handshaking operations of RTSAS and DTSAS of PROFIBUS.

isoLoop® is a registered trademark of NVE Corporation
* US Patent number 5,831,426; 6,300,617 and others

Ordering Information

IL485W	Standard Part Number
IL485WE	Lead Free
IL485WTR	Tape and Reel
IL485WETR	Lead Free/Tape and Reel

IL485W^{isoLoop®}

Absolute Maximum Ratings

Parameters	Symbol	Min.	Max.	Units
Storage Temperature	T_S	-65	150	°C
Ambient Operating Temperature	T_A	-40	85	°C
Voltage Range at A or B Bus Pins		-7	12	Volts
Supply Voltage ⁽¹⁾	V_{DD1}, V_{DD2}	-0.5	7	Volts
Digital Input Voltage		-0.5	5.5	Volts
Digital Output Voltage		-0.5	$V_{DD} + 0.1$	Volts
Continuous Total Power Dissipation			725 377	mWatts (25°C) mWatts (85°C)
Maximum Output Current	I_O		95	mA
Lead Solder Temperature (10s)			260	°C
ESD	2kV Human Body Model			

Insulation Specifications

Parameter	Condition	Min.	Typ.	Max.	Units
Creepage Distance (External)		8.077			mm
Barrier Impedance			$>10^{14} 7$		ΩpF
Leakage Current	240 V_{RMS} 60Hz		0.2		μA

Recommended Operating Conditions

Parameters	Symbol	Min.	Max.	Units
Supply Voltage	V_{DD1}, V_{DD2}	4.5	5.5	Volts
Input Voltage at any bus terminal (separately or common mode)	V_I V_{IC}		12 -7	Volts
High-level Digital Input Voltage	V_{IH}	3		Volts
Low-Level Digital Input Voltage	V_{IL}		0.8	Volts
Differential Input Voltage ⁽²⁾	V_{ID}		+12/-7	Volts
High-Level Output Current (Driver)	I_{OH}		-60	mA
High-Level Digital Output Current (Receiver)	I_{OH}		8	mA
Low-Level Output Current (Driver)	I_{OL}		60	mA
Low-Level Digital Output Current (Receiver)	I_{OL}		8	mA
Operating Free Air Temperature	T_A	-40	85	°C
Digital Input Signal Rise and Fall Times	t_{IR}, t_{IF}	DC Stable		

IEC61010-1

TUV Certificate Numbers: *Pending*

Classification as Table 1.

Model	Pollution Degree	Material Group	Max Working Voltage	Package Type
IL485W	II	III	300 V_{RMS}	16-SOIC (0.3") ✓

UL 1577

Component Recognition program. File #: *Pending*

Rated 2500Vrms for 1min.

Driver Section

All Specifications are T_{min} to T_{max} unless otherwise stated.

Parameter	Symbol	Min.	Typ. ⁽⁶⁾	Max.	Units	Test Conditions
Input Clamp Voltage	V_{IK}			-1.5	V	$I_L = -18mA$
Output Voltage	V_O	0		6	V	$I_O = 0$
Differential Output Voltage	$ V_{OD1} $	1.5		6	V	$I_O = 0$
Differential Output Voltage ⁽⁶⁾	$ V_{OD2} $	1.5	2.5	5	V	$R_L = 54\Omega$
Differential Output Voltage	V_{OD3}	1.5		5	V	$V_{test} = -7$ to 12V
Change in Magnitude of ⁽⁷⁾ Differential Output Voltage	$\Delta V_{OD} $			± 0.2	V	$R_L = 54$ or 100Ω
Common Mode Output Voltage	V_{OC}			3 -1	V	$R_L = 54$ or 100Ω
Change in Magnitude of ⁽⁷⁾ Common Mode Output Voltage	$\Delta V_{OC} $			± 0.2	V	$R_L = 54$ or 100Ω
Output Current ⁽⁹⁾	I_O			1 -0.8	mA mA	Output Disabled $V_O = 12$ $V_O = -7$
High Level Input Current	I_{IH}			10	μA	$V_I = 3.5$ V
Low Level Input Current	I_{IL}			-10	μA	$V_I = 0.4$ V
Short-Circuit Output Current	I_{OS}			-250 -150 250	mA	$V_O = -6$ $V_O = 0$ $V_O = 8$
Supply Current ($V_{DD2} = +5V$) ($V_{DD1} = +5V$)	I_{DD2} I_{DD1}		27 5	34 10	mA mA	No Load (Outputs Enabled)
Switching Characteristics						
Parameter	Symbol	Min.	Typ. ⁽⁶⁾	Max.	Units	Test Conditions
Maximum Data Rate		35			Mbd	$R_L = 54\Omega$, $C_L = 50pF$
Differential Output Delay Time	$t_D(OD)$		16	25	ns	$R_L = 54\Omega$, $C_L = 50pF$
Pulse Skew ⁽¹⁰⁾	$t_{SK(P)}$		1	6	ns	$R_L = 54\Omega$, $C_L = 50pF$
Differential Output Transition Time	$t_T(OD)$		8	10	ns	$R_L = 54\Omega$, $C_L = 50pF$
Output Enable Time To High Level	t_{PZH}		31	65	ns	$R_L = 54\Omega$, $C_L = 50pF$
Output Enable Time To Low Level	t_{PZL}		22	35	ns	$R_L = 54\Omega$, $C_L = 50pF$
Output Disable Time From High Level	t_{PHZ}		28	50	ns	$R_L = 54\Omega$, $C_L = 50pF$
Output Disable Time From Low Level	t_{PLZ}		16	32	ns	$R_L = 54\Omega$, $C_L = 50pF$
Skew Limit ⁽³⁾	$t_{SK(LIM)}$		2	8	ns	$R_L = 54\Omega$, $C_L = 50pF$

IL485W^{ISOLOOP®}

Receiver Section

All Specifications are T_{\min} to T_{\max} unless otherwise stated.

Parameter	Symbol	Min.	Typ. ⁽⁵⁾	Max.	Units	Test Conditions
Positive-going Input Threshold Voltage	V_{IT+}			0.2	V	$V_O = 2.7V, I_O = -0.4mA$
Negative-going Input Threshold Voltage	V_{IT-}	-0.2			V	$V_O = 0.5V, I_O = 8mA$
Hysteresis Voltage ($V_{IT+} - V_{IT-}$)	V_{HYS}		60		mV	
High Level Digital Output Voltage	V_{OH}	$V_{DD} - 0.2$			V	$V_{ID} = 200mV, I_{OH} = -20\mu A$
Low Level Digital Output Voltage	V_{OL}			0.2	V	$V_{ID} = -200mV, I_{OL} = 20\mu A$
High-impedance-state output current	I_{OZ}			± 20	μA	$V_O = 0.4$ to $(V_{DD2} - 0.5)$ V
Line Input Current ⁽⁸⁾	I_I			1 -0.8	mA	Other Input ⁽¹¹⁾ = 0V $V_I = 12V$ $V_I = -7V$
Input Resistance	r_I		50		k Ω	
Supply Current ($V_{DD2} = +5$)	I_{DD2}		27	34	mA	No Load (Outputs Enabled)
($V_{DD1} = +5$)	I_{DD1}		5	10	mA	
Switching Characteristics						
Parameter	Symbol	Min.	Typ. ⁽⁵⁾	Max.	Units	Test Conditions
Maximum Data Rate		35			Mbd	$R_L = 54\Omega, C_L = 50pF$
Propagation Time ⁽⁹⁾	t_{PD}		24	32	ns	$V_O = -1.5$ to $1.5V, C_L = 15pF$
Pulse Skew ⁽¹⁰⁾	$t_{SK(P)}$		1	6	ns	$V_O = -1.5$ to $1.5V, C_L = 15pF$
Skew Limit ⁽³⁾	$t_{SK(lim)}$		2	8	ns	$R_L = 54\Omega, C_L = 50pF$
Output Enable Time To High Level	t_{PZH}		17	24	ns	$C_L = 15pF$
Output Enable Time To Low Level	t_{PZL}		30	45	ns	$C_L = 15pF$
Output Disable Time From High Level	t_{PHZ}		30	45	ns	$C_L = 15pF$
Output Disable Time From Low Level	t_{PLZ}		18	27	ns	$C_L = 15pF$

Electrostatic Discharge Sensitivity

This product has been tested for electrostatic sensitivity to the limits stated in the specifications. However, NVE recommends that all integrated circuits be handled with appropriate care to avoid damage. Damage caused by inappropriate handling or storage could range from performance degradation to complete failure.

Notes:

1. All Voltage values are with respect to network ground except differential I/O bus voltages.
2. Differential input/output voltage is measured at the noninverting terminal A with respect to the inverting terminal B.
3. Skew limit is the maximum difference in any two channels in one device.
4. The power-off measurement in ANSI Standard EIA/TIA-422-B applies to disabled outputs only and is not applied to combined inputs and outputs.
5. All typical values are at $V_{DD1}, V_{DD2} = 5V$ and $T_A = 25^\circ C$.
6. The minimum V_{OD2} with a 100Ω load is either $\frac{1}{2}V_{OD1}$ or $2V$, whichever is greater.
7. $\Delta|V_{OD}|$ and $\Delta|V_{OC}|$ are the changes in magnitude of V_{OD} and V_{OC} , respectively, that occur when the input is changed from one logic state to the other.
8. This applies for both power on and power off, refer to ANSI standard RS-485 for exact condition. The EIA/TIA-422-B limit does not apply for a combined driver and receiver terminal.
9. Includes 8 ns read enable time. Maximum propagation delay is 25 ns after read assertion.
10. Pulse skew is defined as the $|t_{PLH} - t_{PHL}|$ of each channel.

Application Notes:

Power Consumption

Isoloop[®] devices achieve their low power consumption from the manner by which they transmit data across the isolation barrier. By detecting the edge transitions of the input logic signal and converting these to narrow current pulses a magnetic field is created around the GMR Wheatstone bridge. Depending on the direction of the magnetic field, the bridge causes the output comparator to switch following the input logic signal. Since the current pulses are narrow, about 2.5ns wide, the power consumption is independent of mark-to-space ratio and solely dependent on frequency. This has obvious advantages over optocouplers whose power consumption is heavily dependent on its on-state and frequency.

The approximate power supply current per channel for

$$\text{Isoloop}^{\text{®}} \text{ is: } I(\text{input}) = 40 \left(\frac{f}{f_{\text{max}}} \right) \left(\frac{1}{4} \right) \text{ mA}$$

where f = operating frequency
 $f_{\text{max}} = 50 \text{ MHz}$

Power Supplies

It is recommended that low ESR ceramic capacitors be used to decouple the supplies. Both V_{DD1} and V_{DD2} should be bypassed with 47 nF capacitors. These should be placed no further than 1 cm from the device pins for proper operation. In addition, V_{DD2} should have a 10 μF tantalum capacitor connected in parallel with the 47 nF capacitor.

Soldering Profile

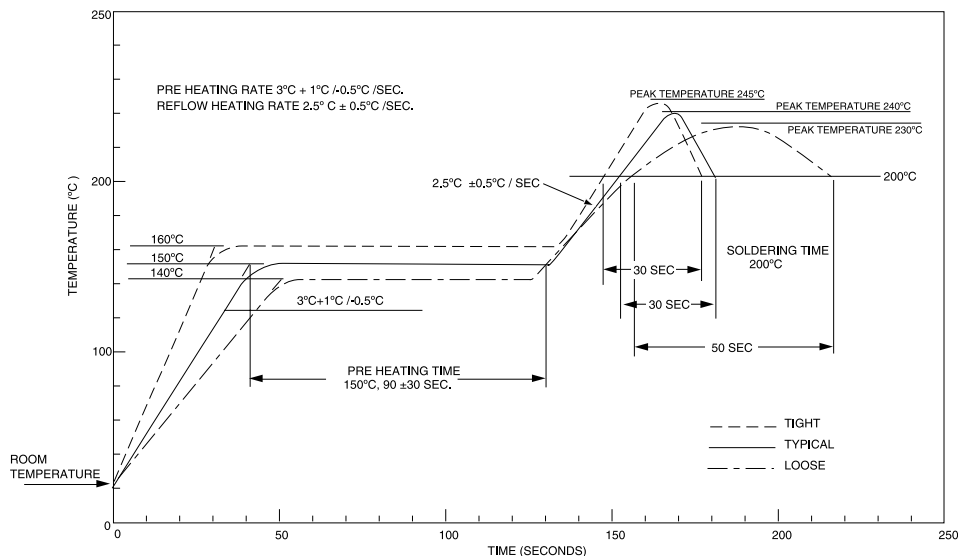

IL485W^{isoLOOP®}

Pin Configuration

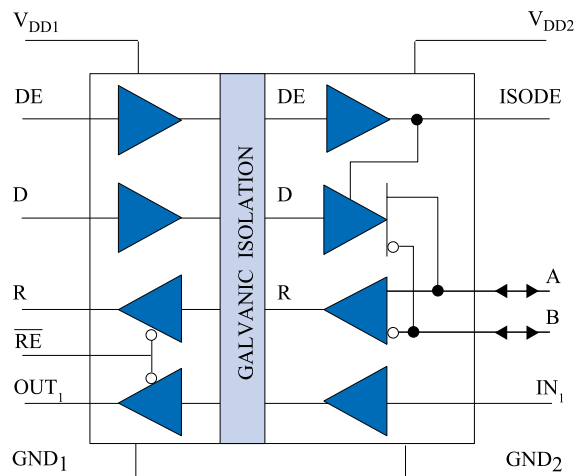
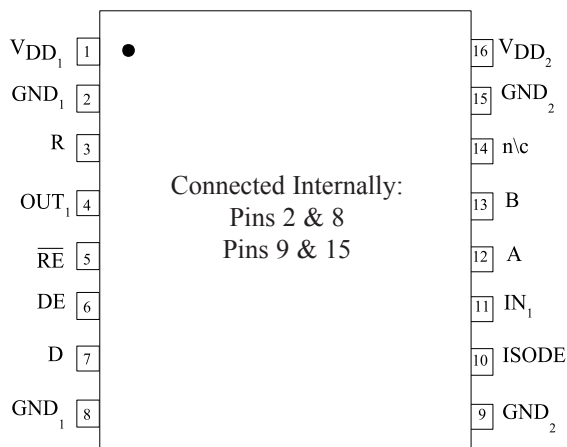

Pin Description

Pin	Mnemonic	Description
1	V _{DD1}	Input Power Supply
2	GND ₁	Input Power Supply Ground Return
3	R	Output Data from Bus
4	OUT ₁	Output From Auxiliary Isolation Channel
5	\overline{RE}	Read Data Enable (if \overline{RE} is high, R is high Impedence)
6	DE	Drive Enable
7	D	Data Input to Bus
8	GND ₁	Input Power Supply Ground Return
9	GND ₂	Output Power Supply Ground Return
10	ISODE	Isolated DE Output for use in Profibus applications where the state of the drive enable node needs to be monitored
11	IN ₁	Input to the Auxiliary Isolation Channel
12	A	'A' Bus Connection to RS485 (True)
13	B	'B' Bus Connection to RS485 (Inverse)
14	nc	No Internal Connection
15	GND ₂	Output Power Supply Return
16	V _{DD2}	Output Power Supply

0.3" SOIC-16 Package

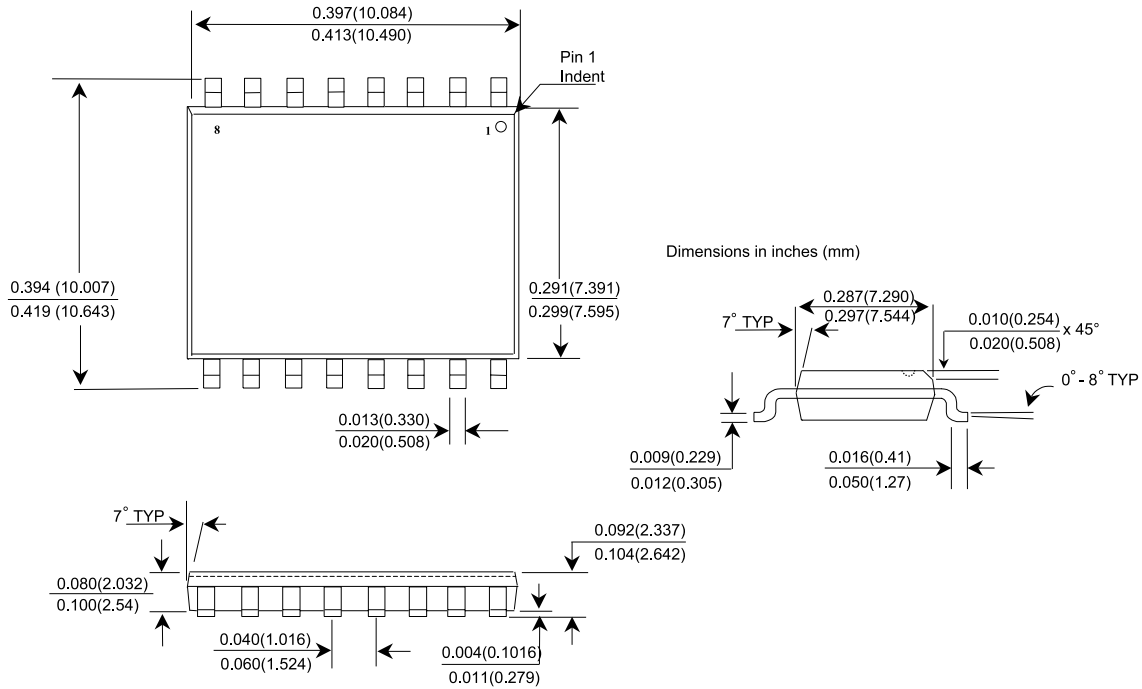

Application: PROFIBUS Fault Interrogation

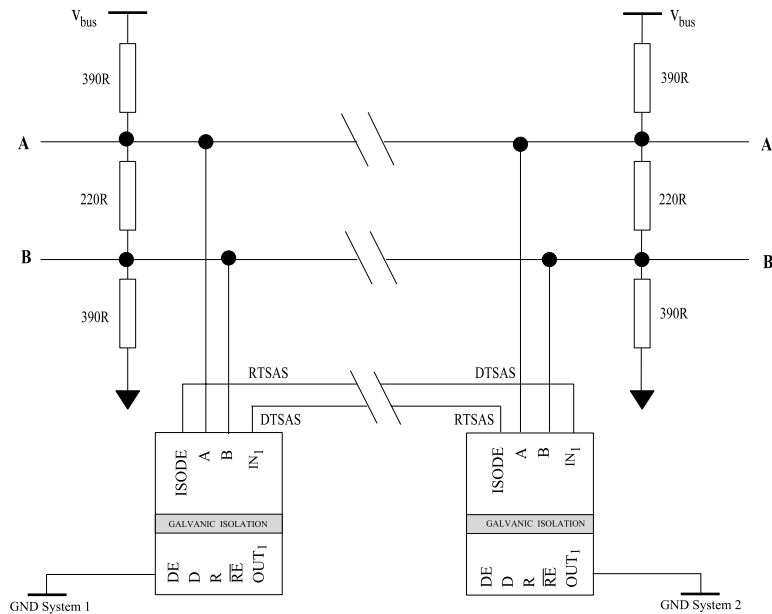



About NVE

An ISO 9001 Certified Company

NVE Corporation is a high technology components manufacturer having the unique capability to combine leading edge Giant Magnetoresistive (GMR) materials with integrated circuits to make high performance electronic components. Products include Magnetic Field Sensors, Magnetic Field Gradient Sensors (Gradiometer), Digital Magnetic Field Sensors, Digital Signal Isolators and Isolated Bus Transceivers.

NVE is a leader in GMR research and in 1994 introduced the world's first products using GMR material, a line of GMR magnetic field sensors that can be used for position, magnetic media, wheel speed and current sensing.

NVE is located in Eden Prairie, Minnesota, a suburb of Minneapolis. Please visit our Web site at www.nve.com or call 952-829-9217 for information on products, sales or distribution.

NVE Corporation
11409 Valley View Road
Eden Prairie, MN 55344-3617 USA
Telephone: (952) 829-9217
Fax: (952) 829-9189
Internet: www.nve.com
e-mail: isoinfo@nve.com

The information provided by NVE Corporation is believed to be accurate. However, no responsibility is assumed by NVE Corporation for its use, nor for any infringement of patents, nor rights or licenses granted to third parties, which may result from its use. No license is granted by implication, or otherwise, under any patent or patent rights of NVE Corporation. NVE Corporation does not authorize, nor warrant, any NVE Corporation product for use in life support devices or systems or other critical applications. The use of NVE Corporation's products in such applications is understood to be entirely at the customer's own risk.

Specifications shown are subject to change without notice.

ISB-DS-001-IL485W-E

June 1, 2005

