

Standard DC Input Modules

Features

- Rugged construction
- Up to 4000 volts of optical isolation (transient)
- Most have a bridge-rectifier input, and accept AC or DC inputs.

Description

Input modules are used for sensing ON/OFF voltage levels. All AC and DC input modules, with the exception of the IDC5B and the IDC5D, have a bridge-rectifier input, and accept AC or DC inputs.

The IDC5B module is a fast-switching input module for signals produced by photoelectric switches or TTL level devices. The IDC5D is a low cost, DC only, input module for use in data acquisition applications.

Each module provides up to 4000 volts (transient) of optical isolation between the field inputs and the output side of the circuit.

Typical uses and applications include sensing the presence or absence of voltage or sensing contact closures from sources such as:

- Proximity switches
- Limit switches
- Selector switches
- Push buttons
- Photoelectric switches
- TTL-compatible devices



IDC5 Input Module

Part Numbers

Part	Description
IDC5	AC/DC Input 10–32, 5 VDC Logic
IDC5B	DC Input 4–16, 5 VDC Logic High Speed
IDC5D	DC Input 2.5–28 VDC, 5 VDC Logic
IDC5G	AC/DC Input 35–60 VDC, 5 VDC Logic
IAC5	AC/DC Input 90–140 VAC, 5 VDC Logic
IAC5A	AC/DC Input 180–280 VAC, 5 VDC Logic
IDC15	AC/DC Input 10–32 VAC, 15 VDC Logic
IAC15	AC/DC Input 90–140 VAC, 15 VDC Logic
IAC15A	AC/DC Input 180–280 VAC, 15 VDC Logic
IDC24	AC/DC Input 10–32 VDC, 24 VDC Logic
IAC24	AC/DC Input 90–140 VAC, 24 VDC Logic
IAC24A	AC/DC Input 180–280 VAC, 24 VDC Logic

Standard DC Input Modules

Module Specifications

General

Operating Ambient Temperature	- 30 to 70 °C
Isolation, Input-to-Output (Transient)	4000 V
Output Voltage Drop: logic side	0.4 volts @ 50 mA
Output Current	50 mA
Output Leakage With No Input IDC5D Only	0.1 mA @ 30 VDC 0.01 mA @ 30 VDC
Transistor	30 volts breakdown

Input Module Specifications

	Unit	IDC5	IDC5B	IDC5D	IDC5G	IDC15*	IDC24*
Input Voltage Range	VDC	10–32	4–16	2.5–28	35–60	10–32	10–32
	VAC	12–32	4–16	—	35–60	12–32	12–32
Input Current @ Max Line	mA	25	45	30	6	25	25
Turn-on Time	msec	5	0.05	1	10	5	5
Turn-off Time	msec	5	0.1	1.5	10	5	5
Input Allowed for No Output	mA	1	0.7	0.2	0.7	1	1
	Volts	3	1	1	7	3	3
Output Supply Voltage-Nominal	VDC	5	5	5	5	15	24
Output Supply Voltage-Range	VDC	4.5–6	4.5–6	4.5–6	4.5–6	12–18	20–30
Output Supply Current @ Nominal Logic Voltage	mA	12	12	12	12	15	18
Input Resistance	Ohms	1.5k	300	900	10k	1.5k	1.5k
Control Resistance (Rc in schematic diagram)	Ohms	220	220	470	220	1k	2.2k

* Not for use with Opto 22 brains.

	Unit	IAC5	IAC15	IAC24	IAC5A	IAC15A*	IAC24A*
Input Voltage Range	VDC	90–140	90–140	90–140	180–280	180–280	180–280
	VAC	90–140	90–140	90–140	180–280	180–280	180–280
Input Current @ Max Line	mA	5	5	5	5	5	5
Turn-on Time	msec	20	20	20	20	20	20
Turn-off Time	msec	20	20	20	20	20	20
Input Allowed for No Output	mA	3	3	3	1	1	1
	Volts	45	45	45	45	45	45
Output Supply Voltage-Nominal	VDC	5	15	24	5	15	24
Output Supply Voltage-Range	VDC	4.5–6	12–18	20–30	4.5–6	12–18	20–30
Output Supply Current @ Nominal Logic Voltage	mA	12	15	18	12	15	15
Input Resistance	Ohms	28k	28k	28k	70k	70k	70k
Control Resistance (Rc in schematic diagram)	Ohms	220	1k	2.2k	220	1k	2.2k

* Not for use with Opto 22 brains.

Standard DC Input Modules

Dimensions

Typical, All Models

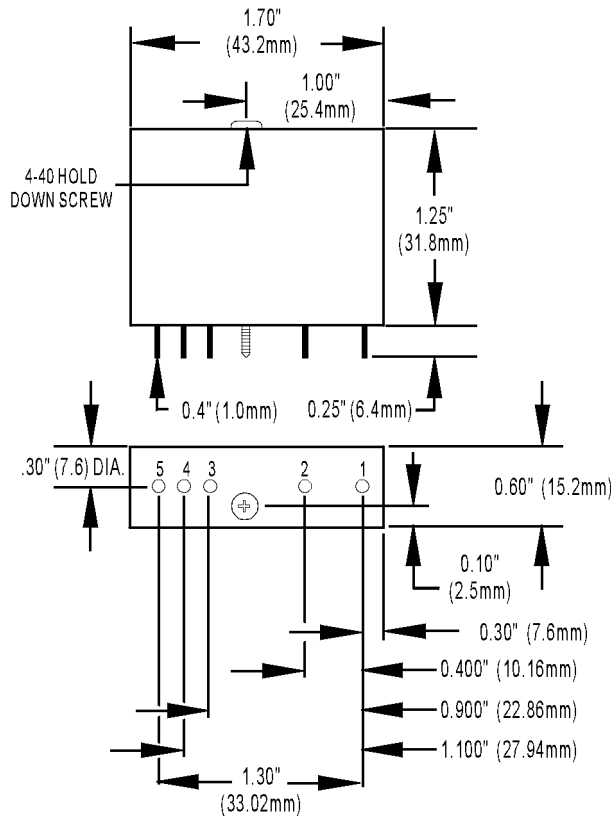

Schematic

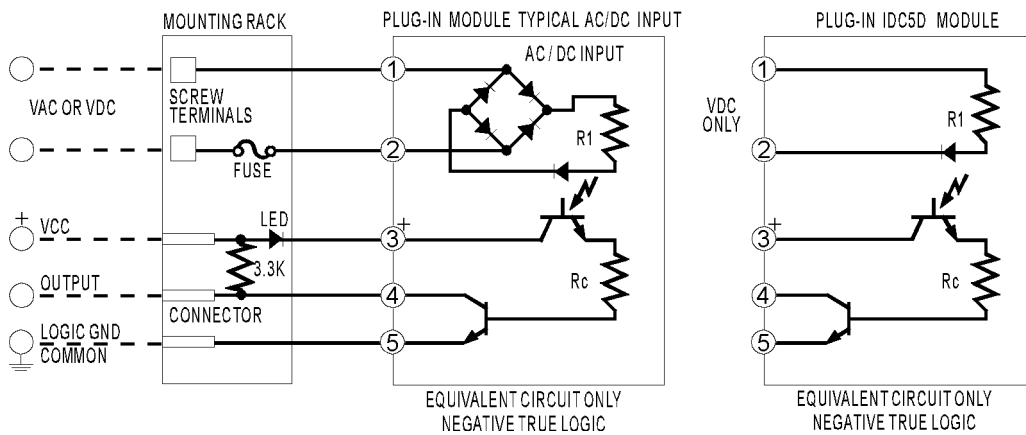

Standard DC Input Modules

Connections

Field Connection Diagram

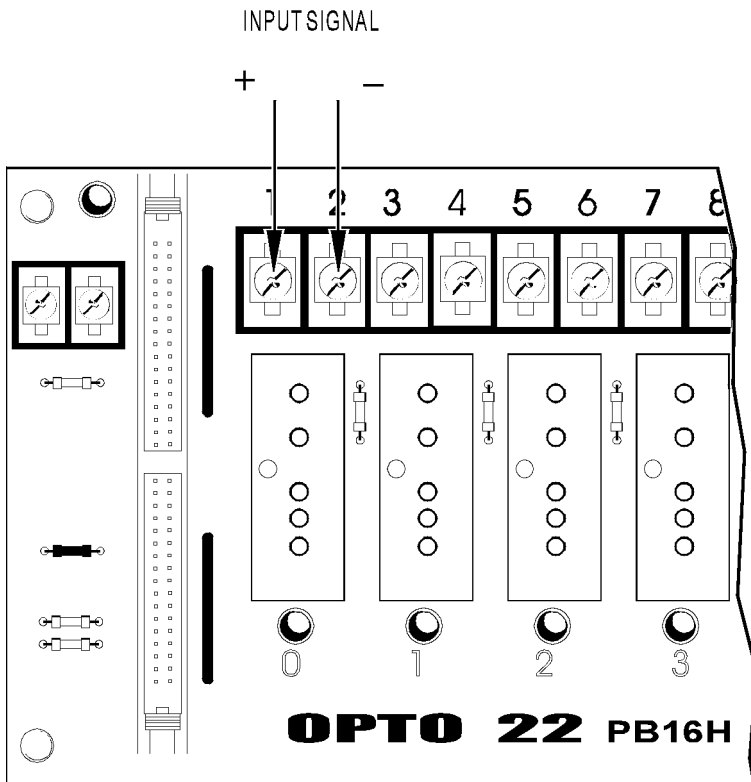

More About Opto 22

Products

Opto 22 develops and manufactures reliable, flexible, easy-to-use hardware and software products for industrial automation, energy management, remote monitoring, and data acquisition applications.

OptoEMU Energy Management System

The easy-to-use OptoEMU Sensor monitors electrical energy use in your facility and delivers detailed, real-time data you can see and analyze. The Sensor can monitor energy data from pulsing meters, electrical panels or subpanels, and equipment. View energy data online using a software service or incorporate the data into your control system for complete energy management.

SNAP PAC System

Designed to simplify the typically complex process of selecting and applying an automation system, the SNAP PAC System consists of four integrated components:

- SNAP PAC controllers
- PAC Project™ Software Suite
- SNAP PAC brains
- SNAP I/O™

SNAP PAC Controllers

Programmable automation controllers (PACs) are multifunctional, modular controllers based on open standards.

Opto 22 has been manufacturing PACs for over two decades. The standalone SNAP PAC S-series and the rack-mounted SNAP PAC R-series both handle a wide range of digital, analog, and serial functions for data collection, remote monitoring, process control, and discrete and hybrid manufacturing.

SNAP PACs are based on open Ethernet and Internet Protocol (IP) standards, so you can build or extend a system easily, without the expense and limitations of proprietary networks and protocols.

PAC Project Software Suite

Opto 22's PAC Project Software Suite provides full-featured, cost-effective control programming, HMI (human machine interface) development and runtime, OPC server, and database connectivity software for your SNAP PAC System.

Control programming includes both easy-to-learn flowcharts and optional scripting. Commands are in plain English; variables and I/O point names are fully descriptive.

PAC Project Basic offers control and HMI tools and is free for download on our website, www.opto22.com. PAC Project Professional, available for separate purchase, adds

OptoOPCServer, OptoDataLink, options for controller redundancy or segmented networking, and support for legacy Opto 22 serial *mistic*™ I/O units.

SNAP PAC Brains

While SNAP PAC controllers provide central control and data distribution, SNAP PAC brains provide distributed intelligence for I/O processing and communications. Brains offer analog, digital, and serial functions, including thermocouple linearization; PID loop control; and optional high-speed digital counting (up to 20 kHz), quadrature counting, TPO, and pulse generation and measurement.

SNAP I/O

I/O provides the local connection to sensors and equipment. Opto 22 SNAP I/O offers 1 to 32 points of reliable I/O per module, depending on the type of module and your needs.

Analog, digital, and serial modules are all mixed on the same mounting rack and controlled by the same processor (SNAP PAC brain or rack-mounted controller).

Quality

Founded in 1974, Opto 22 has established a worldwide reputation for high-quality products. All are made in the U.S.A. at our manufacturing facility in Temecula, California. Because we do no statistical testing and each part is tested twice before leaving our factory, we can guarantee most solid-state relays and optically isolated I/O modules for life.

Free Product Support

Opto 22's California-based Product Support Group offers free, comprehensive technical support for Opto 22 products. Our staff of support engineers represents decades of training and experience. Support is available in English and Spanish by phone or email, Monday–Friday, 7 a.m. to 5 p.m. PST.

Additional support is always available on our website: how-to videos, OptoKnowledgeBase, self-training guide, troubleshooting and user's guides, and OptoForums.

In addition, hands-on training is available for free at our Temecula, California headquarters, and you can [register online](#).

Purchasing Opto 22 Products

Opto 22 products are sold directly and through a worldwide network of distributors, partners, and system integrators. For more information, contact Opto 22 headquarters at 800-321-6786 or 951-695-3000, or visit our website at www.opto22.com.

www.opto22.com