

groov MULTIFUNCTION MIXED SIGNAL MODULE

Features

- > 10 channels per module: 8 multifunction, mixed signal; 2 mechanical relays
- > Module cover with LED indicates module status
- > Touch-sensitive pad triggers display of module information on groov EPIC® processor's display
- > Channel-specific LEDs simplify troubleshooting
- > Operating temperature: -20 to 70 °C
- > UL Hazardous Locations approved and ATEX compliant



GRV-MM1001-10

DESCRIPTION

groov I/O modules are part of the groov EPIC® (Edge Programmable Industrial Controller) system. Wired directly to field devices (sensors and actuators), groov I/O translates the electrical signals from those devices into the digital language computers understand—so you can monitor and control devices and use their data wherever you need it, in your local computer network or in cloud services.

The **GRV-MM1001-10** is a 10-channel, multi-signal, multifunction module that supports thousands of unique field I/O combinations. Configurable through PAC Control, CODESYS, custom control programs, or through groov Manage, you select a channel, configure its I/O signal, select any function supported by the selected channel—such as counting, latching, clamping, and more—and then save your configuration.

Wiring is simplified with a top-mounted connector, which provides spring-clamp terminals for common, power, and field wiring. The connector is held in place by a single, captive retention screw but can be removed with the field wiring intact for wiring in advance or easier module field replacement.

A swinging, two-position cover protects wiring from inadvertent contact, as does the dead-front design. The two positions of the cover

offer the option of more space to accommodate larger wire. The module cover provides a touch-sensitive pad; touch the pad and the groov EPIC processor displays information about the module, including specifications and a wiring diagram.

The module pivots into place and is held securely in place by a captive retention screw.

groov I/O modules are hot swappable (which means they can be installed or removed without turning off power to the unit) and self-identifying—as soon as you mount the module to the chassis, it communicates to the processor and identifies itself.

Each groov I/O module cover provides a large module LED to indicate module health at a glance. Discrete modules also include channel-specific LEDs that display the on/off status of each channel.

Part Numbers

Part	Description
GRV-MM1001-10	8 multifunction, mixed signal channels; 2 form C electromechanical relay output channels

FEATURES AND SPECIFICATIONS

Features

Specifications listed on next page.

GRV-MM1001-10	Signal Type					
	DI: • Discrete • Switch Input, Powered	DO: • DC Sinking	DO: • Form C Mechanical Relay	AI: • Voltage • ICTD • Thermistor • Resistor	AI: • Current • Thermocouple • Millivolt	AO: • Voltage • Current
Channels	0-7	0-7	8-9	0-7	0-3	4-7
Features						
On/off State	x	x	x			
On/off Latching	x					
Counting	x					
On/off Totalization	x					
Frequency Measurement	x					
Period Measurement	x					
Pulse Measurement	x					
Scaling				x	x	x
Offset and Gain				x	x	
Minimum/Maximum Values				x	x	
Average Filter Weight				x	x	
Simple Moving Average				x	x	
Analog Totalizing				x	x	
Output Pulsing / TPO		x				
Ramping						x
Clamping						x
Watchdog Timeout Value		x	x			x
Quality Indication ^a				x	x	x

a. The Quality Indication feature enables a channel to provide a numerical code that describes a characteristic of the signal entering or leaving the channel. For a list of numerical codes and what characteristic they describe, see "Quality Indication" on page 3.

Quality Indication

The following table lists the quality codes the indicated signal type(s) may report.

Code	Reportable by	Description
0	Any channel reporting quality	Data quality is good. No exception conditions occurred.
4	All analog inputs	Analog input is not in range; firmware can't determine if above or below range.
5	All analog inputs	Analog input above operating limits.
6	All analog inputs	Analog input below operating limits.
7	All analog inputs	Module isolated field circuitry in reset; part of module firmware to auto-recover field circuitry that may be in an undefined state.
8	All analog inputs and outputs	Module failed communication with isolated field circuitry like analog to digital and digital to analog converters.
13	Thermocouple inputs	Table lookup calculation beyond plus table end.
14	Thermocouple inputs	Table lookup calculation beyond minus table end.
18	All analog outputs	<p>Analog output fault.</p> <ul style="list-style-type: none"> • When configured for voltage, indicates the load resistance is too low (that is, the load is drawing too much current to maintain the voltage). • When configured for current, indicates very high resistance or possible open circuit.
19	All analog outputs	Analog output driver over temperature condition, output may cycle on and off.
20	<ul style="list-style-type: none"> • Switch input, powered • ICTD input • Thermistor input (for curves: 2252, 3K, 10K type 2, 10K type 3, and Custom) • 0–400 kOhm input 	Field excitation/loop voltage fault
23	<ul style="list-style-type: none"> • ICTD input • Thermocouple input 	Isolated field compensation circuitry or calculation does not give valid data.
30	Any channel reporting quality	Channel not present.

Specifications

Specification	GRV-MM1001-10
Voltage Input	
Available Channels	0–7
Input Range	0–10 V DC
Over-range Limit	0–11 V DC
Resolution	0.5 mV
Accuracy	±0.05% of range (±5 mV)
Gain Temperature Coefficient	10 ppm/°C
Offset Temperature Coefficient	1 ppm/°C
Input Impedance	> 425 kOhms
Data Refresh Time	550 ms x SMA value (1.1 s @ 2 SMA, Default SMA = 2)
50 / 60 Hz rejection	> 90 dB
Current Input	
Available Channels	0–3
Input Range	0–20 mA
Over-range Limit	0–20.8 mA
Recommended Fuse	32–40 mA, Fast Acting (for example, Eaton S500-32-R)
Resolution	1.0 µA
Accuracy	±0.075% (±15 µA)
Gain Temperature Coefficient	25 ppm/°C
Offset Temperature Coefficient	1 ppm/°C
Input Voltage Drop (±10%)	0.9 V @ 4 mA, 2.0 V @ 20 mA, 25 °C
Equivalent Input Impedance (±10%)	225 Ohms @ 4 mA, 100 Ohms @ 20 mA, 25 °C
Data Refresh Time	550 ms x SMA value (1.1 s @ 2 SMA, Default SMA = 2)
50 / 60 Hz rejection	> 90 dB

Continued on next page.

Specification	GRV-MM1001-10
ICTD Input	
Available Channels	0–7
Input Range with ICTD Probe	-40 to +100 °C
Resolution	0.04 °C
Accuracy with ICTD Probe	±0.5 °C (0.9 °F)
Gain Temperature Coefficient	2 ppm/°C
Offset Temperature Coefficient	175 ppm/°C
Data Refresh Time	550 ms x SMA value (1.1 s @ 2 SMA, Default SMA = 2)
50 / 60 Hz rejection	> 90 dB
Thermocouple Input	
Available Channels	0–3 (see Note)
Input Range	-75 to +75 mV
Over-range Limit	-78 to +78 mV
Input Resolution	3 microvolts
Input Impedance	> 1 megohm
Data Refresh Time	550 ms x SMA value (1.1 s @ 2 SMA, Default SMA = 2)
50 / 60 Hz rejection	> 90 dB
Thermocouple ITS90 Types	± Accuracy / Resolution
B: 90 °C to 1,820 °C	7 °C / 0.4 °C
E: -80 °C to 1,000 °C	2 °C / 0.1 °C
J: -100 °C to 1,200 °C	2 °C / 0.1 °C
K: -80 °C to 1,372 °C	2 °C / 0.1 °C
N: -100 °C to 1,300 °C	3 °C / 0.1 °C
R: 100 °C to 1,768 °C	7 °C / 0.3 °C
S: 100 °C to 1,768 °C	7 °C / 0.3 °C
T: -60 °C to 400 °C	3 °C / 0.1 °C

Note: To achieve the best thermocouple accuracy when also using current outputs or discrete outputs, always configure thermocouples on the lowest channel numbers and outputs on the highest channel numbers.

Continued on next page.

Specification	GRV-MM1001-10
Millivolt Input	
Available Channels	0–3
Input Ranges	±150 mV, ±75 mV, ±25 mV
Over-range Limits	±165.0 mV, ±78.0 mV, ±27.5 mV
Resolution	10 µV, 3 µV, 2 µV
Accuracy	±0.05% of Full Scale (±75 µV), ±0.05% of Full Scale (±37.5 µV), ±0.05% of Full Scale (±12.5 µV)
Gain Temperature Coefficient	10 ppm/°C, 10 ppm/°C, 10 ppm/°C
Offset Temperature Coefficient	1 ppm/°C, 1 ppm/°C, 4 ppm/°C
Input Impedance	> 1 MOhms
Data Refresh Time	550 ms x SMA value (1.1 s @ 2 SMA, Default SMA = 2)
50 / 60 Hz rejection	> 90 dB
Thermistor Input	
Available Channels	0–7 (see Note)
Input Range (Ohms)	0–400 k
Accuracy (Ohms @ Range)	greater of 3 Ohms or 0.5% @ 0–25k, 400 @ 25k–50k, 900 @ 50k–75k, 1.5k @ 75k–100k, 5k @ 100k–200k, 20k @ 200k–400k
Gain Temperature Coefficient	500 ppm/°C
Resolution (Ohms @ Range)	0.5 @ 0–1k, 1 @ 1k–5k, 2 @ 5k–10k, 5 @ 10k–25k, 50 @ 25k–100k, 200 @ 100k–200k, 700 @ 200k–400k
Power Dissipation @ Resistance (µW @ Ohms)	375 @ 1k, 950 @ 5k, 1075 @ 10k, 875 @ 25k, 600 @ 50k, 450 @ 75k, 350 @ 100k, 200 @ 200k, 100 @ 400k
Predefined Thermistor Curves	Accuracy (°C) @ Range (°C)
2252	0.2 @ -40 to 70, 2.5 @ 70 to 150
3K	0.2 @ -40 to 70, 2.5 @ 70 to 150
10K type 2	0.75 @ -40 to -20, 0.2 @ -20 to 120, 0.6 @ 120 to 150
10k type 3	0.5 @ -40 to -20, 0.3 @ -20 to 120, 0.6 @ 120 to 150
Custom	depends on curve
Gain Temp Coefficient	0.015/(°C * Ohm)
Data Refresh Time	550 ms x SMA value (1.1 s @ 2 SMA, Default SMA = 2)
Note: To achieve the best thermistor accuracy when also using current outputs, always configure thermistors on the lowest channel numbers and current outputs on the highest channel numbers.	

Continued on next page.

Specification	GRV-MM1001-10
0–400 kOhm Input	
Available Channels	0–7 (see Note)
Input Range (Ohm)	0–400k
Accuracy (Ohm @ Range)	greater of 3 Ohm or 0.5% @ 0–25k, 400 @ 25k–50k, 900 @ 50k–75k, 1.5k @ 75k–100k, 5k @ 100k–200k, 20k @ 200k–400k
Gain Temperature Coefficient	500 ppm/°C
Resolution (Ohm @ Range)	0.5 @ 0–1k, 1 @ 1k–5k, 2 @ 5k–10k, 5 @ 10k–25k, 50 @ 25k–100k, 200 @ 100k–200k, 700 @ 200k–400k
Power Dissipation @ Resistance (µW @ Ohm)	375 @ 1k, 950 @ 5k, 1075 @ 10k, 875 @ 25k, 600 @ 50k, 450 @ 75k, 350 @ 100k, 200 @ 200k, 100 @ 400k
Data Refresh Time	550 ms x SMA value (1.1 s @ 2 SMA, Default SMA = 2)

Note: To achieve the best resistance accuracy when also using current outputs, always configure the 0-400 kOhm channel type on the lowest channel numbers and current outputs on the highest channel numbers.

Switch Input, Powered	
Available Channels	0–7
Open Circuit Voltage (Switch Open)	10.5 V (minimum)
Channel Current Limit	1.1 mA max.
Channel Operating Current	0.63 mA typical
Minimum Off Resistance	3300 Ohms
Maximum On Resistance	1200 Ohms
Minimum ON Voltage	5 V
Maximum OFF Voltage	1.5 V
Maximum Continuous Survivable Input Voltage	32 V
Input Impedance	> 425 kOhms
Max. Freq. (50% square wave)	10000 Hz

Continued on next page.

Specification	GRV-MM1001-10
Discrete Counter Input	
Available Channels	0–7
Input Voltage Range	5–30 V DC
ON Threshold	5 V
OFF Threshold	1.5 V
Input Impedance	> 425 kOhms
Max. Frequency (50% square wave): State, Latches, Counter	10000 Hz
Max. Frequency (50% square wave): On/Off pulse width, Period, Frequency	2000 Hz
Max. Frequency (50% square wave): On/Off totalization	750 Hz
Pulse Width Measurement Resolution	100 microseconds
Pulse Width Measurement Error (50% square wave)	0.1% 0 to 20 Hz 1% 21 to 200 Hz 5% 201 to 2000 Hz
Period/Frequency Error (50% square wave)	0.05% 0 to 20 Hz 0.1% 21 to 200 Hz 1% 201 to 2000 Hz
Discrete DC Sinking Output	
Available Channels	0–7 (4–7 if using any thermocouple inputs)
Line Voltage Range	5–30 V DC
Maximum Continuous Current	1.0 A
Peak Current (< 10 ms)	4.0 A
Recommended Fuse / Circuit Breaker	1 A at 30 V DC
Output Voltage Drop	175 mV at 1 A
Off-State Leakage (per channel)	< 80 μ A at 24 V, -20 to +70 °C
Peak Blocking Voltage	32 V
TPO Period (min, max, resolution)	0.004 seconds, 4294967 seconds, 0.001 seconds
Turn On / Off Time	20 ms nominal
Form C Relay Output	
Available Channels	8, 9
Line Voltage Range	0–250 V AC or 5–30 V DC
Clamp Voltage	440 V nominal
Current Rating	3.5 A per channel
Surge Current	6 A peak for 1 second
Recommended Fuse / Circuit Breaker	5 A at 250 V AC / > 30 V DC per channel
Initial Contact Resistance	< 100 mOhms
Turn On Time	8 ms
Turn Off Time	4 ms
Operating Life (to specification)	Min. 30,000 cycles at max. ratings
Mechanical Life	Min. 10,000,000 cycles

Continued on next page.

Specification	GRV-MM1001-10
Voltage Output	
Available Channels	4–7
Range	0–10 V
Resolution	2.5 mV
Accuracy	±0.35% of range (±35 mV)
Gain Temperature Coefficient	20 ppm/°C
Offset Temperature Coefficient	3 ppm/°C
Output Slew Rate	> 15 V/ms
Minimum Load Resistance	7.5 kOhms
Output Impedance	< 10 Ohms
Short-circuit Current	20 mA
Data Refresh Time	Nominal 20 ms. Proportional to I/O scan time.
Current Output	
Available Channels	4–7
Output Range	0–20 mA
Resolution	5 µA
Accuracy	±0.4% of range (±80 µA)
Offset Temperature Coefficient	5 ppm/°C
Output Slew Rate	> 10 mA/ms
Maximum Loop Resistance	700 Ohms
Data Refresh Time	Nominal 20 ms. Proportional to I/O scan time.
Common Specifications	
Power Consumption	5 W
Max. Survivable Input (channels 0–7)	32 V DC
Isolation (between channels 0–7)	None
Isolation (between channel 8 or 9 and all others)	3000 V AC _{rms} 1 min.
Isolation (field to Ethernet / power input)	1500 V AC _{rms} 1 min.
Minimum <i>groov</i> EPIC Firmware Version	3.3.0
Minimum PAC Project Version	10.4000
Minimum Library Package for CODESYS Version	2.0.3.0
Wire Size	28–14 AWG
Torque, connector screw	2.5 in-lb (0.28 N-m)
Torque, hold-down screw	3.5 in-lb (0.4 N-m)
Temperature (operating)	-20 °C to +70 °C
Temperature (storage)	-40 °C to +85 °C
Relative Humidity (non-condensing)	5–95%
Agency Approvals	UL/cUL(Class 1 Div. 2); CE, ATEX(Category 3, Zone 2); RoHS; DFARS; CB Scheme
Warranty	30 months

MOUNTING & REMOVING

Mount *groov* I/O modules onto a *groov* EPIC chassis (see [groov EPIC Chassis Data Sheet](#), form 2247). To learn the names and physical features of the parts of the module, see "Description of Module Parts" on page 15.

Mounting the Module

The numbers on the diagrams correspond to the numbered steps in these instructions.

CAUTION: For electrical safety, de-energize field devices wired to the terminal connector before starting.

1. Orient the *groov* EPIC chassis so that the module connector numbers are right-side up, with module connector zero on the left, as shown in the diagram.
2. Hold the module at a 45° angle, lining up the alignment tab on the back tip of the module with the slot at the back of the chassis.
3. Pivot the front of the module down to the module connector on the chassis. Push to snap the module into the connector.
4. Swing the module cover up so you can access the module retention screw. Secure the module into position by tightening the module retention screw.

CAUTION: Do not over-tighten. See the torque specs in the Specifications table.

5. If the module does not have a terminal connector, install one.
6. Secure the terminal connector by tightening the terminal connector screw.

CAUTION: Do not over-tighten. See the torque specs in the Specifications table.

7. Follow the wiring instructions in the Pinout and Wiring section to wire your field devices to the channels on the terminal connector.
8. When wiring is complete, swing the module cover back down to cover the wires. If the wires are too thick to close the module cover easily, lift the module cover, then raise the back of the module cover up to the higher position. Swing the module cover back down to cover the wires.

When you are done installing modules and wiring, if you powered down your unit, you can turn it back on.

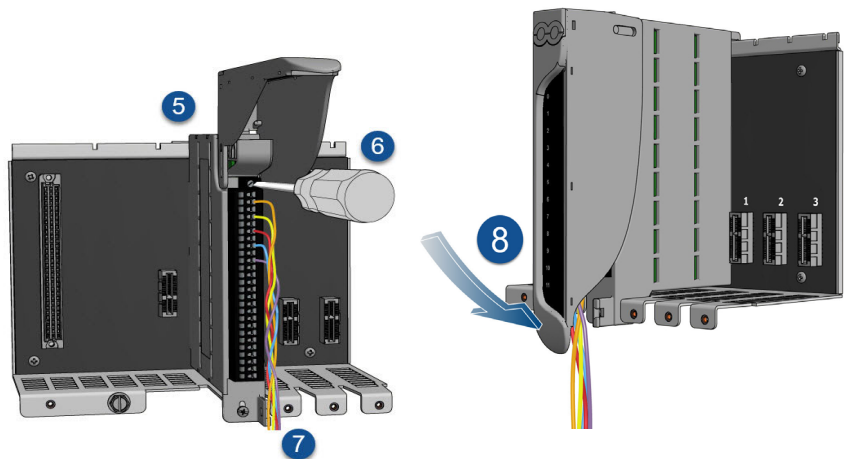
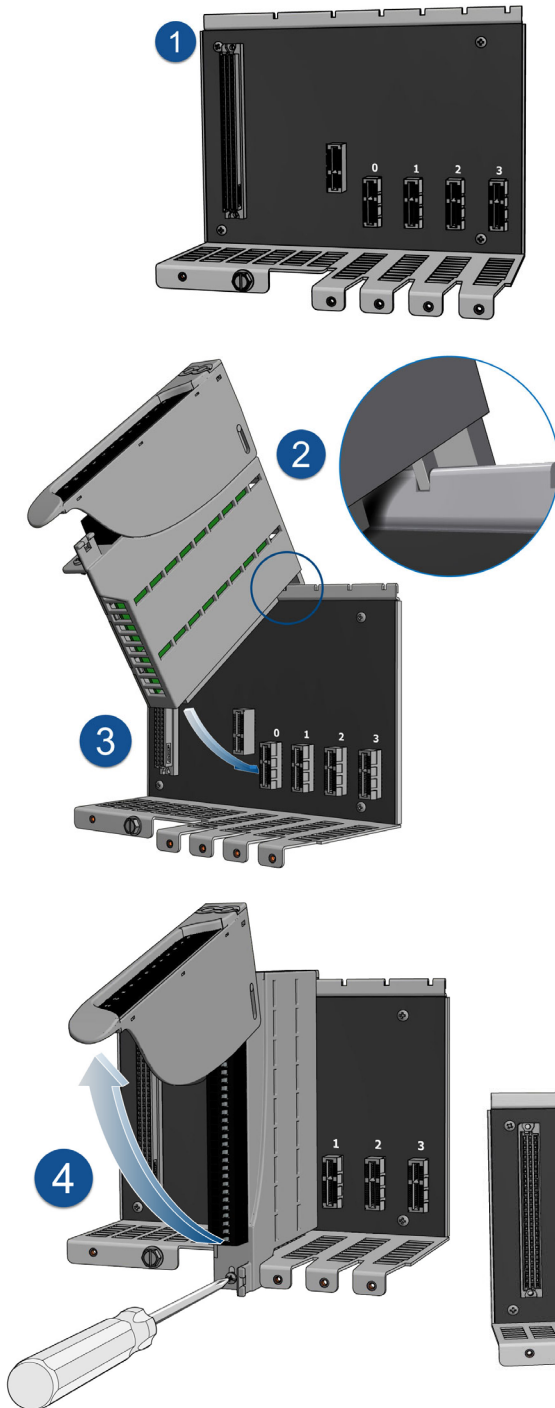

Removing the Module

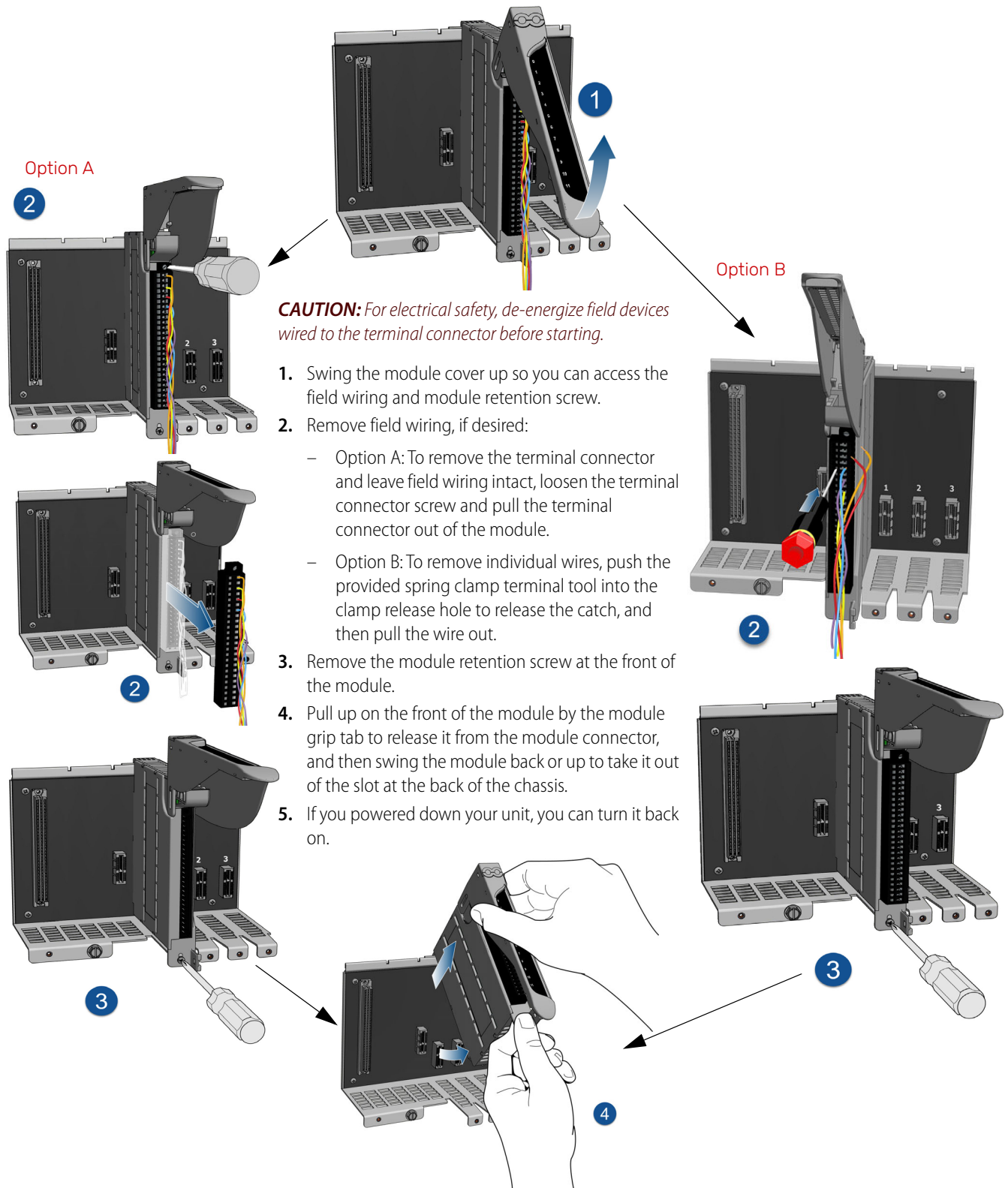

PINOUT AND WIRING

Before you begin wiring, do the following tasks:

- Select the appropriate wire. The terminal connectors are rated for 28–14 AWG wire. If you're using stranded wire, you can make an easier and better connection by tinning the strands or adding ferrules.
- Ensure that you have the *groov* spring-clamp terminal tool, typically supplied with a *groov* EPIC chassis. (You can order a replacement on our website, www.opto22.com. Search for [GRV-TEX-SCTOOL](#).)
- If you are unfamiliar with the names of some of the parts of the module, review the diagrams on this page and in the Description of Module Parts section.
- It may be easier to insert wires if you remove the terminal connector from the module. To remove the terminal connector,

loosen the terminal connector screw at one end of the connector, then pull the connector straight out to remove it from the module.

- If you have never used a spring-clamp wiring system, take a moment to familiarize yourself with the diagram below. The clamp release hole is where you will insert the spring-clamp terminal tool. The field wiring hole is where you will insert your field wires.

If you look into the field wiring hole, you will see a highly reflective surface. If you can see that surface, that means that the clamp is closed.

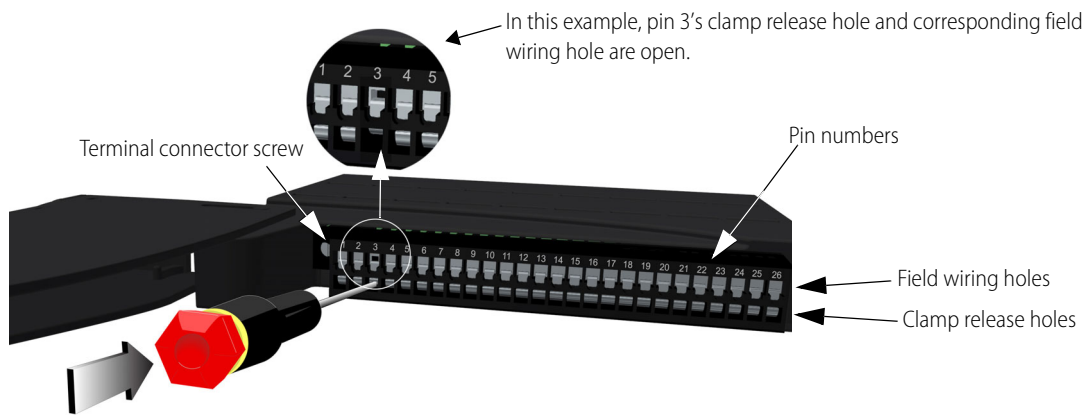

Follow these instructions to connect your field wires to the module:

CAUTION: For electrical safety, before starting, de-energize field devices wired to the terminal connector.

1. Orient the module or terminal connector to match the wiring diagrams on the following page. To make it easier to handle the spring-clamp terminal tool and the field wires, secure the module by doing one of the following:
 - If you are working with the terminal connector while it is attached to the module, make sure the module is screwed securely to the chassis.
 - If you are working only with the terminal connector, secure the terminal connector with a clamp.
2. Insert the spring-clamp terminal tool into the clamp release hole, then press and hold down the tool to open the clamp. Look into the field wiring hole. If it is dark, the clamp is open. You can go to [step 3](#). If you can still see the highly reflective surface, gently push down again and keep downward pressure on the spring-clamp

terminal tool. Look into the field wiring hole. If it is dark, the clamp is open.

Note: If you push in too hard, the spring-clamp terminal tool might pop out of the clamp release hole.

3. Insert the wire into the field wiring hole until it meets complete resistance. Then pull out the spring-clamp terminal tool.
4. Test that the wire is secure by gently pulling on it. If the wire pulls out, repeat steps 2 and 3.

To remove a wire, push the spring-clamp terminal tool into the clamp release hole as described in [step 2](#) above, and then pull the wire out.

WIRING: GRV-MM1001-10

			INPUT					OUTPUT				
			Discrete		Analog			Discrete	Analog	Mechanical Relay		
			Discrete	Switch Input, Powered	Voltage	Current ²	ICTD	Thermocouple/ Millivolt ³	DC Sinking ^{1,3}	Current / Voltage	Form C-NO ¹	Form C-NC ¹
Channel	Internal Wiring	Pin										
Ch 0	1	1										
		2										
Ch 1	4	4										
		5										
Ch 2	7	7										
		8										
Ch 3	10	10										
		11										
Ch 4	13	13										
		14										
Ch 5	15	15										
		16										
Ch 6	17	17										
		18										
Ch 7	19	19										
		20										
Ch 8	21	21										- NC
		22										- COM
		23										- NO
Ch 9	24	24										- NC
		25										- COM
		26										- NO

Notes:

1. You must supply external fusing.
2. Opto 22 recommends adding external fusing. Review the specification table for specific ratings. Compatible with an externally powered or self powered transmitter. Wiring for externally powered transmitter is shown on channels 0 and 1. Wiring for a self powered transmitter is shown on channels 2 and 3.
3. Thermocouple inputs and discrete sinking outputs cannot be mixed on channels 0-3.



DIMENSIONS: GRV-MM1001-10

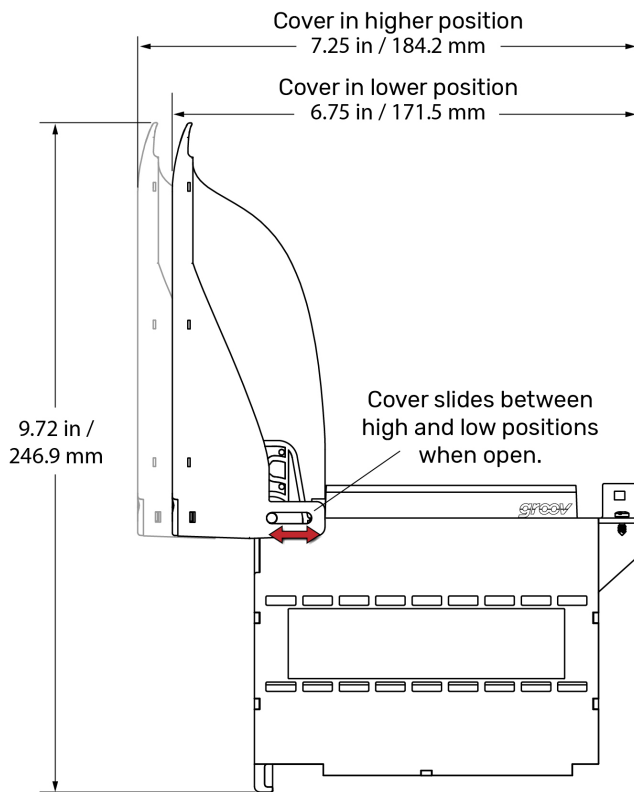

The module cover pivots and can be adjusted to two different heights (positions). The higher position provides more space to accommodate thicker wires.

To switch between higher and lower position, open the cover to at least a 45° angle. Grasp the hinged end of the module cover and do one of the following:

- Pull up on the back hinge to slide it to the higher position.
- Push down on the back hinge to slide it to the lower position.

You cannot switch between the higher and lower positions while the cover is closed.

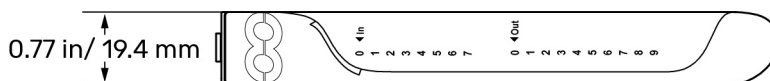
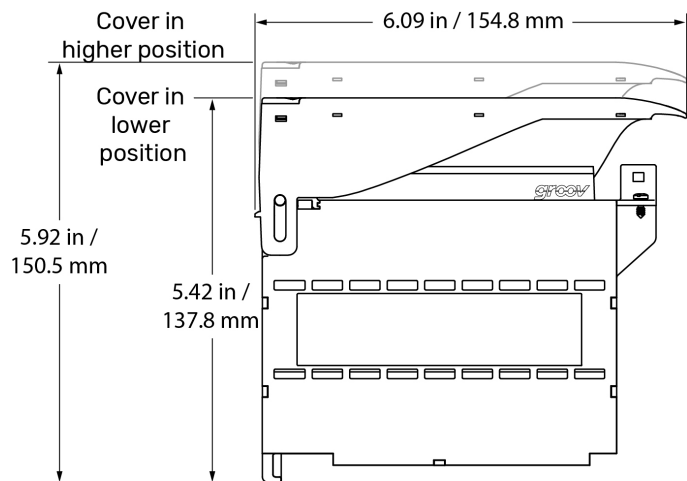
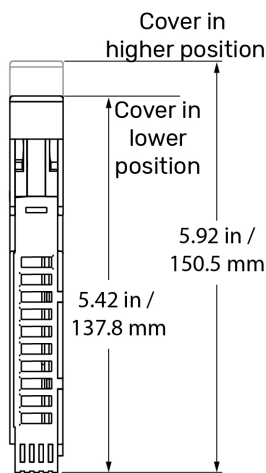

DESCRIPTION OF MODULE PARTS

The following diagram identifies the parts of the modules. The installation instructions in the documentation rely on these terms to describe how to handle the module.

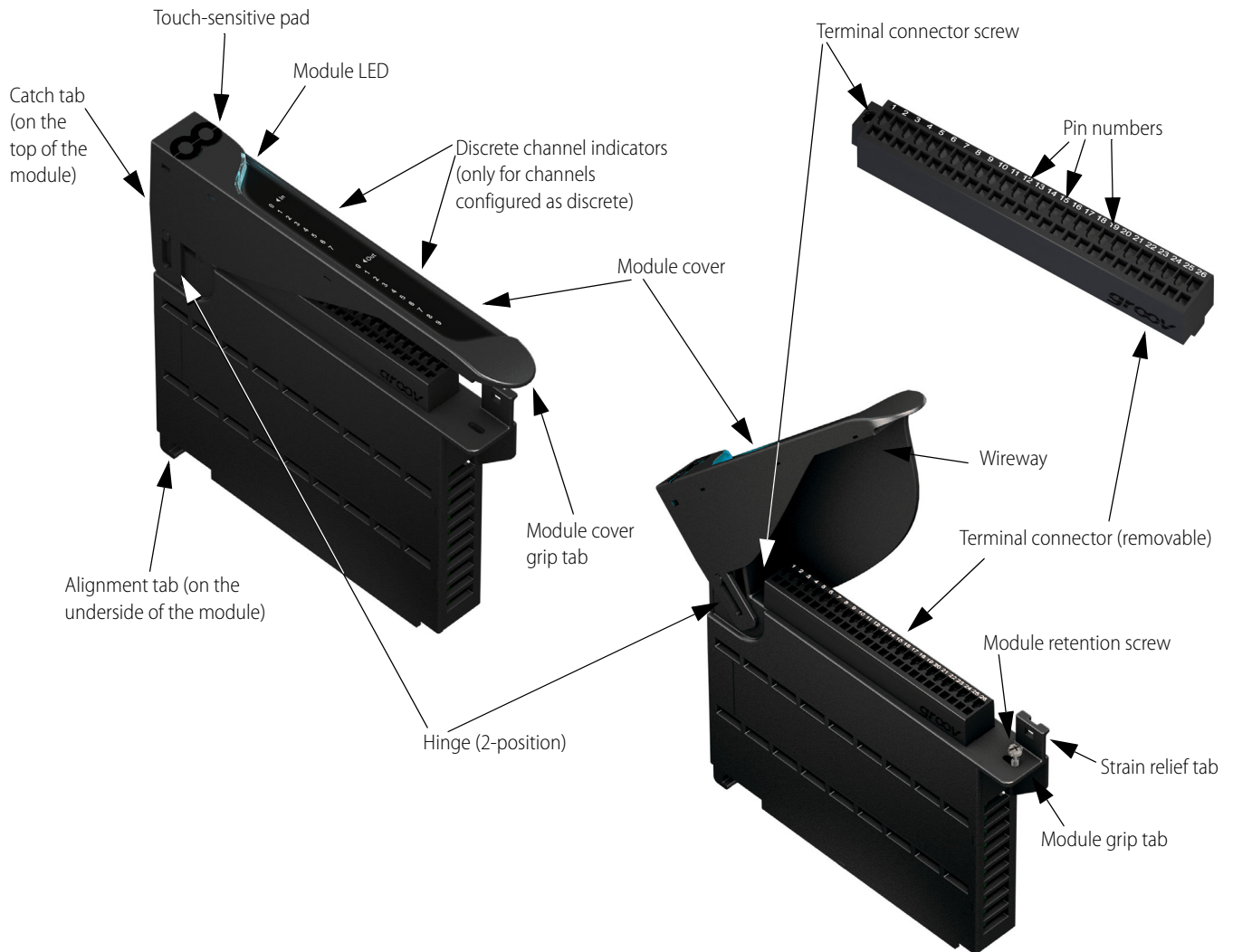

Some parts offer unique features:

- Module LED:** Provides a visual indication of the health of the module. For example, if it is blue, the module is operating normally. If it is blinking blue, the module's information is being displayed on the *groov* EPIC processor's screen. For a complete list of the various colors that this LED might display, see the [groov EPIC User's Guide](#) (form 2267).
- Terminal connector:** Specially designed for *groov* I/O modules, it provides a spring-clamp wiring system to securely connect the wires from your field devices to the module. To learn how to use a spring-clamp wiring system, see the Pinouts and Wiring section.
- Hinge and Wireway:** These two features work together to provide more space for wires. The hinge can be adjusted between a lower position and a higher position. The wireway is the space underneath the module cover. To increase this space, you can raise the hinge to the higher position.
- Discrete channel indicators:** Available only when a channel is configured as discrete, the indicator lights up when the channel is on. If the channel is configured as analog, the indicator remains off.
- Touch-sensitive pad:** Offers a convenient way to display the module's information on the *groov* EPIC processor. Press on the pad for approximately two seconds and the processor displays

that module's information on the screen, as well as changing the module LED to a blinking blue light.

- **Catch tab:** Located at the top of the module, the catch tab provides a place for the cover to "catch" or stop. This prevents the cover from closing so that you can work on attaching or detaching wires to the terminal connector.

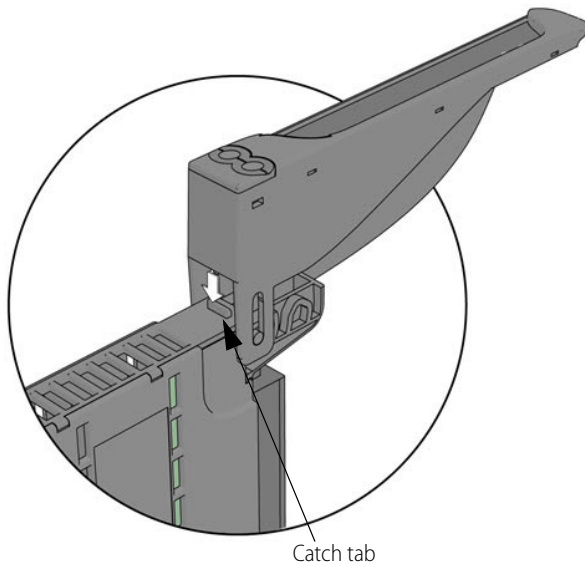

- **Strain relief tab:** This tab offers a way to collect wires into a bundle and secure them to the module. Attaching the wires to the strain relief tab can help hold the wires in a semi-fixed position, preventing them from interfering while you work on a nearby module. It also prevents strain on the part of the wire attached to the terminal connector.

Collect the wires into a bundle, pull a zip tie through the hole in the tab, wrap the zip tie around the bundle and tab, then clip the excess zip tie.

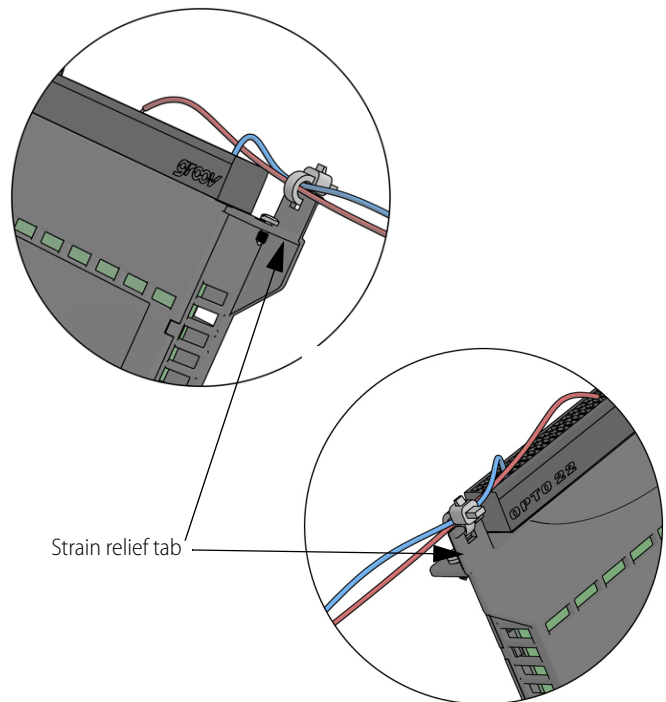

PRODUCTS

Opto 22 develops and manufactures reliable, easy-to-use, open standards-based hardware and software products. Industrial automation, process control, building automation, industrial refrigeration, remote monitoring, data acquisition, and industrial internet of things (IIoT) applications worldwide all rely on Opto 22.

groov EPIC® System

Opto 22's *groov Edge Programmable Industrial Controller (EPIC) system* gives you an industrially hardened system with guaranteed-for-life I/O, a flexible Linux®-based processor with gateway functions, and software for your automation and IIoT applications.

groov EPIC I/O

groov I/O connects locally to sensors and equipment with up to 24 channels on each I/O module. Modules have a spring-clamp terminal strip, integrated wireway, swing-away cover, and LEDs indicating module health and discrete channel status.

groov I/O is hot swappable, UL Hazardous Locations approved, and ATEX compliant.

groov EPIC Processor

The heart of the system is the *groov EPIC* processor. It handles a wide range of digital, analog, and serial functions for data collection, remote monitoring, process control, and discrete and hybrid manufacturing.

In addition, the EPIC provides secure data communications among physical assets, control systems, software applications, and online services, both on premises and in the cloud.

Configuring and troubleshooting I/O and networking is easier with the EPIC's integrated high-resolution color touchscreen. Authorized users can manage the system locally on the touchscreen or on a monitor connected via the HDMI or USB ports.

groov EPIC Software

Software included in the *groov EPIC* processor:

- PAC Control engine to run PAC Control and PAC Display
- CODESYS Runtime engine to run IEC61131-3 compliant programs built with CODESYS Development System
- Optional access to the Linux operating system through a secure shell (SSH) to download and run custom applications
- *groov View* for building your own device-independent HMI, viewable on the touchscreen, PCs, and mobile devices
- Node-RED for creating simple logic flows from pre-built nodes
- Ignition Edge® from Inductive Automation®, with OPC-UA drivers to Allen-Bradley®, Siemens®, and other control systems, and MQTT communications with Sparkplug for efficient IIoT data transfer

groov RIO®

groov RIO revolutionizes remote I/O by offering a single, compact, PoE-powered industrial package with web-based configuration, commissioning, and flow logic software built in, plus support for multiple OT and IT protocols.

Standing alone, it meets the needs of small, variable I/O count applications, especially those that require data logging or data communications, commonly found in IIoT applications. *groov RIO* can also be used with a Modbus/TCP master or as remote I/O for a *groov EPIC* system.

Older products

From solid state relays (our first products) to world-famous G4 and SNAP I/O, to SNAP PAC controllers, older Opto 22 products are still supported and still doing the job at thousands of installations worldwide. You can count on us to give you the reliability and service you expect, now and in the future.



QUALITY

Founded in 1974, Opto 22 has established a worldwide reputation for high-quality products. All are made in the U.S.A. at our manufacturing facility in Temecula, California.

Because we test each product twice before it leaves our factory rather than testing a sample of each batch, we can afford to guarantee most solid-state relays and optically isolated I/O modules for life.

FREE PRODUCT SUPPORT

Opto 22's California-based Product Support Group offers free, comprehensive technical support for Opto 22 products from engineers with decades of training and experience. Support is available in English and Spanish by phone or email, Monday–Friday, 7 a.m. to 5 p.m. PST.

Support is always available on our website, including [free online training](#) at OptoU, how-to [videos](#), [user's guides](#), the Opto 22 KnowledgeBase, troubleshooting tips, and [OptoForums](#). In addition, instructor-led, hands-on [Premium Factory Training](#) is available at our Temecula, California headquarters, and you can [register online](#).

PURCHASING OPTO 22 PRODUCTS

Opto 22 products are sold directly and through a worldwide network of distributors, partners, and system integrators. For more information, contact Opto 22 headquarters at **800-321-6786** (toll-free in the U.S. and Canada) or **+1-951-695-3000**, or visit our website at www.opto22.com.