

G4 Digital AC Output Modules

Features

- ▶ 4000 volts optical isolation (transient)
- ▶ Built-in LED status indicator
- ▶ Logic levels of 5, 15, and 24 VDC
- ▶ Removable fuse
- ▶ Current rating: 3 amps at 45° C
- ▶ UL Motor Load rating: 1.5 amps
- ▶ Ability to withstand one-cycle surge of 80 amps
- ▶ Operating temperature: -30 °C to 70 °C



G4OAC5A and
G4OAC5AMA Modules

Description

Opto 22's G4 AC output modules are used to control or switch AC loads. Each module provides up to 4000 volts of optical isolation (transient) between field outputs and the control side of the circuit, and each features zero voltage turn-on and zero current turn-off. All AC output modules are equivalent to single-pole, single-throw, normally open contacts (Form A, SPST-NO) except the G4OAC5A5, which is equivalent to a single-pole, single-throw, normally closed contact (Form B, SPST-NC).

Each module is equipped with a 4 amp fast-blow fuse. The fuse breaking capacity is 40 amps at 250 VAC. Current should be limited to prevent the short circuit current from exceeding the rated breaking capacity of the fuse.

The G4OAC5MA and the G4OAC5AMA are special modules featuring a manual-on/manual-off/automatic switch, ideal for diagnostic testing of control applications.

Typical applications for AC output modules include switching loads such as AC relays, solenoids, motor starters, heaters, lamps, and indicators.

Part numbers ending in FM are Factory Mutual approved.

Part Numbers

Part	Description
G4OAC5	G4 AC Output 12–140 VAC, 5 VDC Logic
G4OAC5FM	G4 AC Output 12–140 VAC, 5 VDC Logic, Factory Mutual Approved
G4OAC5A	G4 AC Output 24–280 VAC, 5 VDC Logic
G4OAC5AFM	G4 AC Output 24–280 VAC, 5 VDC Logic, Factory Mutual Approved
G4OAC5A5	G4 AC Output 24–280 VAC, 5 VDC Logic NC
G4OAC5A5FM	G4 AC Output 24–280 VAC, 5 VDC Logic NC, Factory Mutual Approved
G4OAC5MA	G4 AC Output 12–140 VAC, 5 VDC Logic With Manual/Auto Switch
G4OAC5AMA	G4 AC Output 24–280 VAC, 5 VDC Logic With Manual/Auto Switch
G4OAC15	G4 AC Output 12–140 VAC, 15 VDC Logic
G4OAC15A	G4 AC Output 24–280 VAC, 15 VDC Logic
G4OAC24	G4 AC Output 12–140 VAC, 24 VDC Logic
G4OAC24A	G4 AC Output 24–280 VAC, 24 VDC Logic

G4 Digital AC Output Modules

Specifications

	Units	G4OAC5 G4OAC5FM*	G4OAC5A G4OAC5AFM*	G4OAC5A5 G4OAC5A5FM*	G4OAC5MA	G4OAC5AMA
Nominal line voltage	VAC	120	120/240	120/240	120	120/240
Output voltage range	VAC	12–140	24–280	24–280	12–140	24–280
Key feature	—	—	—	Normally closed	Diagnostic switch	Diagnostic switch
Current rating: At 45 °C ambient At 70 °C ambient	A A	3 2	3 2	3 2	3 2	3 2
UL Motor Load Rating	A	1.5	1.5	1.5	1.5	1.5
Isolation input-to- output (transient): 1 ms 1 minute	volts	4000 1500	4000 1500	4000 1500	4000 1500	4000 1500
Off-state leakage at nominal voltage (60 Hz)	mA _{RMS}	5	1.25/2.5	1.25/2.5	5	1.25/2.5
Nominal logic voltage	VDC	5	5	5	5	5
Logic voltage range	VDC	4–8	4–8	4–8	4–8	4–8
Logic pickup voltage	VDC	4	4	4	4	4
Logic dropout voltage	VDC	1	1	1	1	1
Logic input current at nominal logic voltage	mA	12	12	12	12	12
Control resistance (R _c in schematic)	ohms	220	220	220	220	220
One-cycle surge	A peak	80	80	80	80	80
Turn-on time @ 60 Hz	milliseconds	≤8.3**	≤8.3**	≤8.3**	≤8.3**	≤8.3**
Turn-off time @ 60 Hz	milliseconds	≤8.3***	≤8.3***	≤8.3***	≤8.3***	≤8.3***
Peak repetitive voltage	VAC	500	500	500	500	500
Minimum load current	mA	20	20	20	20	20
Output voltage drop maximum peak	V	1.6	1.6	1.6	1.6	1.6
Operating frequency	Hz	25–65	25–65	25–65	25–65	25–65
dV/dT-off-state	V/micro- seconds	200	200	200	200	200
dV/dT-commutating	--	snubbed for 0.5 power factor load	snubbed for 0.5 power factor load	snubbed for 0.5 power factor load	snubbed for 0.5 power factor load	snubbed for 0.5 power factor load
Temperature Operating: Storage:	°C °C	-30 to +70 -30 to +85	-30 to +70 -30 to +85	-30 to +70 -30 to +85	-30 to +70 -30 to +85	-30 to +70 -30 to +85

* Part numbers ending in FM are Factory Mutual approved.

** One-half cycle maximum. Module turns on at the zero volt crossing of the AC sine wave.

*** One-half cycle maximum. Module turns off at the zero current crossing of the AC sine wave.

G4 Digital AC Output Modules

Specifications (cont.)

	Units	G4OAC15***	G4OAC15A***	G4OAC24***	G4OAC24A***
Nominal line voltage	VAC	120	120/240	120	120/240
Output voltage range	VAC	12–140	24–280	12–140	24–280
Key feature	—	—	—	—	—
Current rating: At 45 °C ambient At 70 °C ambient	A A	3 2	3 2	3 2	3 2
UL Motor Load Rating	A	1.5	1.5	1.5	1.5
Isolation input-to-output (transient): 1 ms 1 minute	volts	4000 1500	4000 1500	4000 1500	4000 1500
Off-state leakage at nominal voltage (60 Hz)	mA _{RMS}	5	1.25/2.5	5	1.25/2.5
Logic voltage range	VDC	10.5–16	10.5–16	19.5–32	19.5–32
Logic pickup voltage	VDC	10.5	10.5	19.5	19.5
Logic dropout voltage	VDC	1	1	1	1
Logic input current at nominal logic voltage	mA	15	15	18	18
Control resistance (R _c in schematic)	ohms	1 K	1 K	2.2 K	2.2 K
One-cycle surge	A peak	80	80	80	80
Turn-on time @ 60 Hz	micro-seconds	≤8.3*	≤8.3*	≤8.3*	≤8.3*
Turn-off time @ 60 Hz	micro-seconds	≤8.3**	≤8.3**	≤8.3**	≤8.3**
Peak repetitive voltage	VAC	500	500	500	500
Minimum load current	mA	20	20	20	20
Output voltage drop maximum peak	V	1.6	1.6	1.6	1.6
Operating frequency	Hz	25–65	25–65	25–65	25–65
dV/dT-off-state	V/micro-second	200	200	200	200
dV/dT-commutating	--	snubbed for 0.5 power factor load	snubbed for 0.5 power factor load	snubbed for 0.5 power factor load	snubbed for 0.5 power factor load
Temperature Operating: Storage:	°C °C	-30 to +70 -30 to +85	-30 to +70 -30 to +85	-30 to +70 -30 to +85	-30 to +70 -30 to +85

* One-half cycle maximum. Module turns on at the zero volt crossing of the AC sine wave.

** One-half cycle maximum. Module turns off at the zero current crossing of the AC sine wave.

*** Not for use with Opto 22 brains.

G4 Digital AC Output Modules

Dimensions

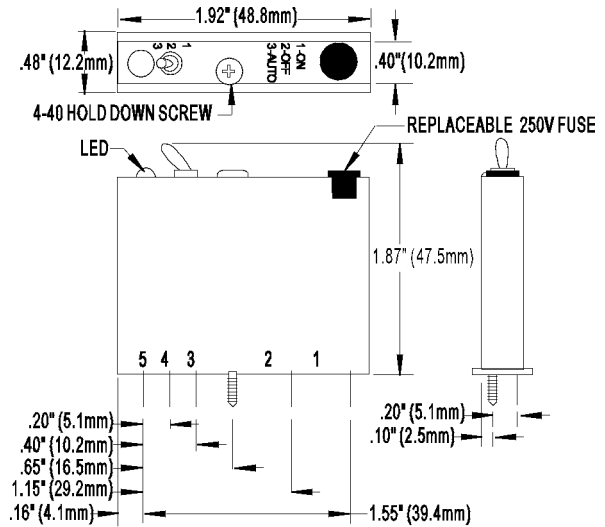
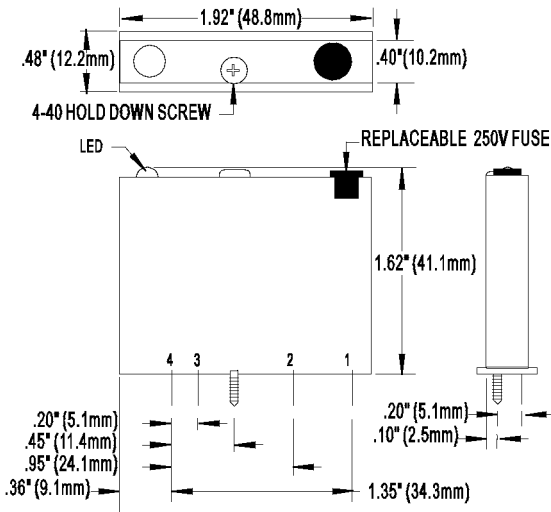

Schematics

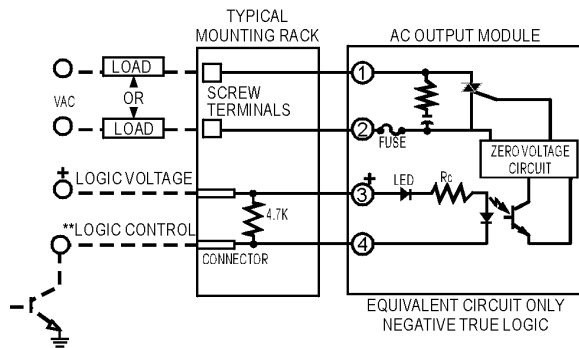

**Control line is compatible with totem pole or tri-state output device.

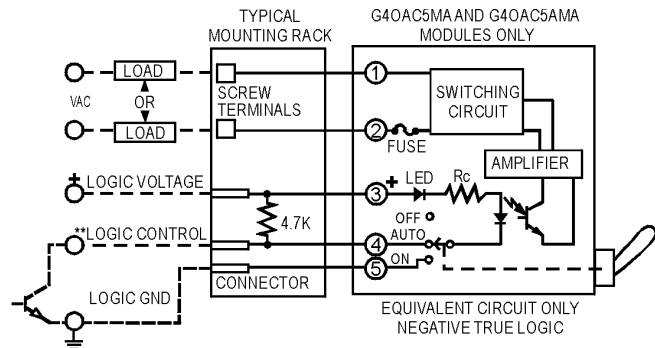

** Control line is compatible with totem pole or tri-state output device.

More About Opto 22

Products

Opto 22 develops and manufactures reliable, flexible, easy-to-use hardware and software products for industrial automation, energy management, remote monitoring, and data acquisition applications.

OptoEMU Energy Management System

The easy-to-use OptoEMU Sensor monitors electrical energy use in your facility and delivers detailed, real-time data you can see, analyze, and use in building and control systems. The Sensor can monitor energy data from pulsing meters, electrical panels or subpanels, and equipment. View energy data online using a software service or incorporate the data into your control system for complete energy management.

SNAP PAC System

Designed to simplify the typically complex process of selecting and applying an automation system, the SNAP PAC System consists of four integrated components:

- SNAP PAC controllers
- PAC Project™ Software Suite
- SNAP PAC brains
- SNAP I/O™

SNAP PAC Controllers

Programmable automation controllers (PACs) are multifunctional, modular controllers based on open standards.

Opto 22 has been manufacturing PACs for over two decades. The standalone SNAP PAC S-series, the rack-mounted SNAP PAC R-series, and the software-based SoftPAC™ all handle a wide range of digital, analog, and serial functions for data collection, remote monitoring, process control, and discrete and hybrid manufacturing.

SNAP PACs are based on open Ethernet and Internet Protocol (IP) standards, so you can build or extend a system easily, without the expense and limitations of proprietary networks and protocols. Wired+Wireless™ models are also available.

PAC Project Software Suite

Opto 22's PAC Project Software Suite provides full-featured, cost-effective control programming, HMI (human machine interface) development and runtime, OPC server, and database connectivity software for your SNAP PAC System.

Control programming includes both easy-to-learn flowcharts and optional scripting. Commands are in plain English; variables and I/O point names are fully descriptive.

PAC Project Basic offers control and HMI tools and is free for download on our website, www.opto22.com. PAC Project Professional, available for separate purchase, adds one

SoftPAC, OptoOPCServer, OptoDataLink, options for controller redundancy or segmented networking, and support for legacy Opto 22 serial *mistic*™ I/O units.

SNAP PAC Brains

While SNAP PAC controllers provide central control and data distribution, SNAP PAC brains provide distributed intelligence for I/O processing and communications. Brains offer analog, digital, and serial functions, including thermocouple linearization; PID loop control; and optional high-speed digital counting (up to 20 kHz), quadrature counting, TPO, and pulse generation and measurement.

SNAP I/O

I/O provides the local connection to sensors and equipment. Opto 22 SNAP I/O offers 1 to 32 points of reliable I/O per module, depending on the type of module and your needs.

Analog, digital, and serial modules are all mixed on the same mounting rack and controlled by the same processor (SNAP PAC brain or rack-mounted controller).

Quality

Founded in 1974, Opto 22 has established a worldwide reputation for high-quality products. All are made in the U.S.A. at our manufacturing facility in Temecula, California. Because we test each product twice before it leaves our factory, rather than only testing a sample of each batch, we can guarantee most solid-state relays and optically isolated I/O modules for life.

Free Product Support

Opto 22's California-based Product Support Group offers free, comprehensive technical support for Opto 22 products. Our staff of support engineers represents decades of training and experience. Support is available in English and Spanish by phone or email, Monday–Friday, 7 a.m. to 5 p.m. PST.

Additional support is always available on our website: how-to videos, OptoKnowledgeBase, self-training guide, troubleshooting and user's guides, and OptoForums.

In addition, hands-on training is available for free at our Temecula, California headquarters, and you can [register online](#).

Purchasing Opto 22 Products

Opto 22 products are sold directly and through a worldwide network of distributors, partners, and system integrators. For more information, contact Opto 22 headquarters at 800-321-6786 or 951-695-3000, or visit our website at www.opto22.com.

www.opto22.com

