

MOS FET Relays

G3VM-81LR

World's Smallest SSOP Package MOS FET Relays with Low Output Capacitance and ON Resistance ($C \times R = 37.5\text{pF} \cdot \Omega$) in a 80-V Load Voltage Model.

• Information correct as of December, 2006, according to data obtained by OMRON.

RoHS compliant

⚠ Refer to "Common Precautions".

Application Examples

- Semiconductor inspection tools
- Measurement devices
- Broadband systems
- Data loggers



Note: The actual product is marked differently from the image shown here.

List of Models

Contact form	Terminals	Load voltage (peak value)	Model	Minimum packaging unit
				Number per tape
SPST-NO	Surface-mounting terminals	80 VAC	G3VM-81LR	---
			G3VM-81LR (TR)	1,500

Dimensions

Note: All units are in millimeters unless otherwise indicated.

G3VM-81LR

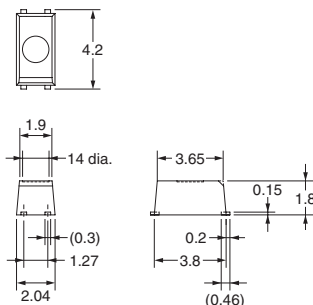
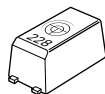

Note: The actual product is marked differently from the image shown here.

Note: A tolerance of ± 0.1 mm applies to all dimensions unless otherwise specified.

Weight: 0.03 g

Terminal Arrangement/Internal Connections (Top View)

G3VM-81LR

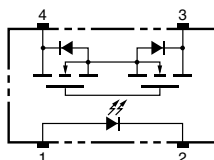

Actual Mounting Pad Dimensions (Recommended Value, Top View)

G3VM-81LR

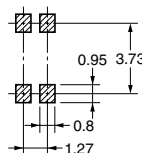

Absolute Maximum Ratings (Ta = 25°C)

Item	Symbol	Rating	Unit	Measurement Conditions	
Input	LED forward current	I_F	50	mA	
	Repetitive peak LED forward current	I_{FP}	---	A	
	LED forward current reduction rate	$\Delta I_F/^\circ\text{C}$	-0.5	mA/°C	
	LED reverse voltage	V_R	5	V	
	Connection temperature	T_j	125	°C	
Output	Output dielectric strength	V_{OFF}	80	V	
	Continuous load current	I_O	120	mA	
	ON current reduction rate	$\Delta I_O/^\circ\text{C}$	-1.2	mA/°C	
	Connection temperature	T_j	125	°C	
Dielectric strength between input and output (See note 1.)		V_{I-O}	1,500	Vrms	AC for 1 min
Ambient operating temperature		T_a	-20 to +85	°C	With no icing or condensation
Storage temperature		T_{stg}	-40 to +125	°C	With no icing or condensation
Soldering temperature		---	260	°C	10 s

Note: 1. The dielectric strength between the input and output was checked by applying voltage between all pins as a group on the LED side and all pins as a group on the light-receiving side.

Electrical Characteristics (Ta = 25°C)

Item	Symbol	Minimum	Typical	Maximum	Unit	Measurement conditions	
Input	LED forward voltage	V_F	1.0	1.15	1.3	V	$I_F = 10 \text{ mA}$
	Reverse current	I_R	---	---	10	μA	$V_R = 5 \text{ V}$
	Capacity between terminals	C_T	---	15	---	pF	$V = 0, f = 1 \text{ MHz}$
	Trigger LED forward current	I_{FT}	---	2	5	mA	$I_O = 120 \text{ mA}$
Output	Maximum resistance with output ON	R_{ON}	---	7.5	12	Ω	$I_F = 10 \text{ mA}, I_O = 120 \text{ mA}, t = 10 \text{ ms}$
	Current leakage when the relay is open	I_{LEAK}	---	---	200	pA	$V_{OFF} = 80 \text{ V}, T_a = 60^\circ\text{C}$
	Capacity between terminals	C_{OFF}	---	5	7	pF	$V = 0, f = 100 \text{ MHz}, t < 1 \text{ s}$
Capacity between I/O terminals		C_{I-O}	---	0.8	---	pF	$f = 1 \text{ MHz}, V_s = 0 \text{ V}$
Insulation resistance between I/O terminals		R_{I-O}	1,000	---	---	M Ω	$V_{I-O} = 500 \text{ VDC}, RoH \leq 60\%$
Turn-ON time		t_{ON}	---	0.1	0.25	ms	$I_F = 10 \text{ mA}, R_L = 200 \Omega, V_{DD} = 20 \text{ V}$ (See note 2.)
Turn-OFF time		t_{OFF}	---	0.15	0.2	ms	

Note: 2. Turn-ON and Turn-OFF Times

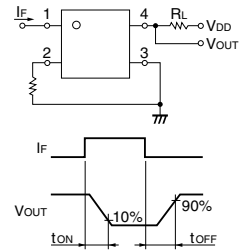

Recommended Operating Conditions

Use the G3VM under the following conditions so that the Relay will operate properly.

Item	Symbol	Minimum	Typical	Maximum	Unit
Output dielectric strength	V_{DD}	---	---	64	V
Operating LED forward current	I_F	10	---	30	mA
Continuous load current	I_O	---	---	120	mA
Operating temperature	T_a	25	---	60	°C

Engineering Data

Load Current vs. Ambient Temperature

G3VM-81LR

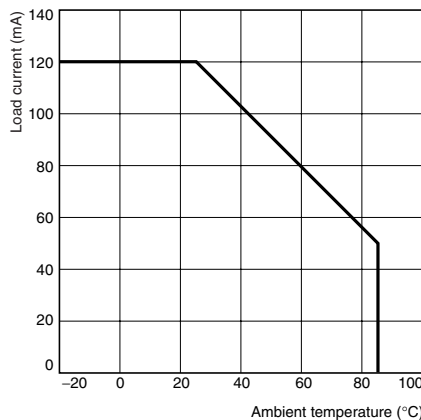

Safety Precautions

Refer to "Common Precautions" for all G3VM models.