



Atex pending, contact factory for details

GENESIS POLYCARBONATE ENCLOSURE

Features and Benefits

- Integra's larger size, polycarbonate enclosure offering
- Light grey in color with high gloss finish
- Featuring Integra's unique "Multi-Max Rail Mounting System" (an extremely flexible interior mounting system)
- Sturdy, full length piano hinged door
- Extra rigid construction utilizing unique internal frame stiffener
- Brass inserts on rear wall of enclosure and on lid for more mounting options
- Brass inserts for securing mounting flanges to rear of enclosure
- Available in four non-metallic latch or three point latch configurations
- UL/C-UL-50 listed Nema 2,3,3R,3S,4,4X,12, 13 rated

The Integra Genesis series represents the beginning of best medium sized non metallic enclosures available. The unmatched flexibility of the interior of this enclosure combined with off the shelf accessories make the first of the Genesis series enclosures ideal for almost any application.

Mechanical and Thermal Test Spec.	Unit	Premium Line
Instrumented Dart Impact @ 73° F	in/lb.	565
Falling Ball Impact @ 73° F	in/lb.	900
Deflection Temperature @ 264 psi	ASTM D648	Deg. F 270
Modulus of Elasticity	m ASTM D790	ksi 340
Temperature Range	Deg. F	-40 to 265
Flammable / UV Ratings Test Spec.	Unit	Premium Line
Flame Rating - UL	UL 94	- 5VA
Outdoor UV Exposure	UL	- F1

24x24 P/N	Nema 4X (IP66)	Hinged Cover	Opaque Cover	Mounting Flange	Polycarbonate Locking Latch	Multi-Max Rail System	3-Point	1/4 Turn
G242410	✓	✓	✓	✓	✓	✓		
G242410TPL	✓	✓	✓	✓		✓	✓	
G242410QTL	✓	✓	✓	✓		✓		✓
G242410P560*	✓	✓	✓	✓	✓			

G242410P560 - excludes Frame Stiffener and Multi-Max Rail System®

G242410 includes the following

Enclosure, Frame Stiffener, Set of Four Multi-Max Rails (with Screws), Two Mounting Flanges (with Screws), and Four Latches

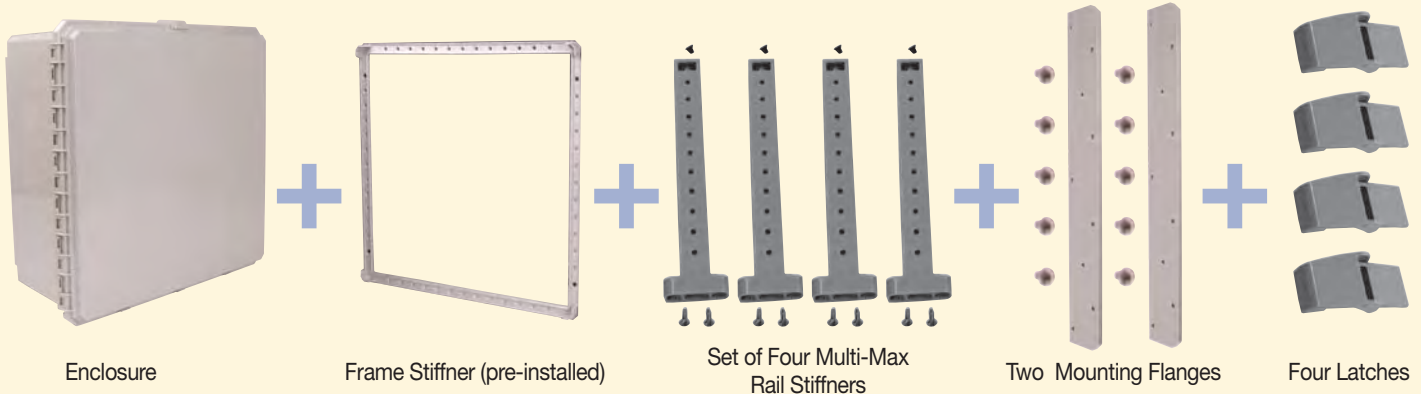



24X24X10 GENESIS LINE

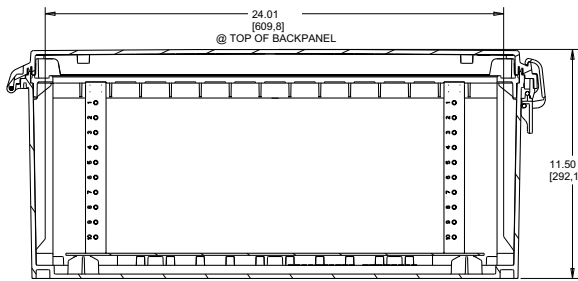
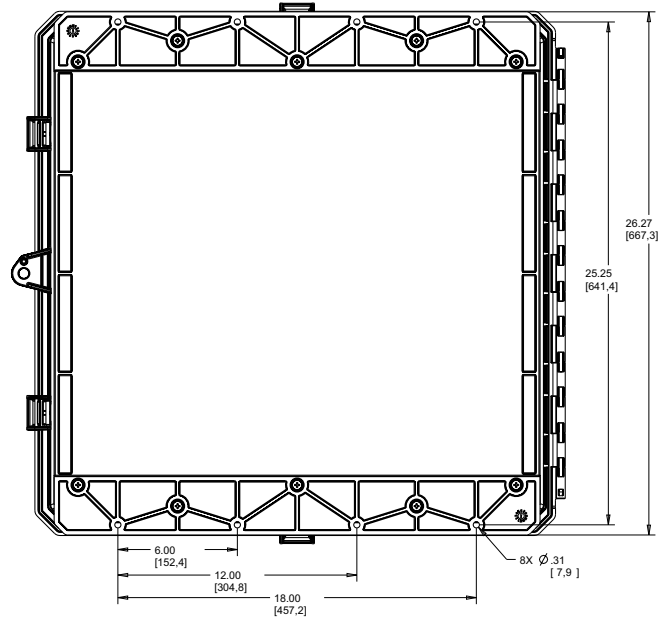
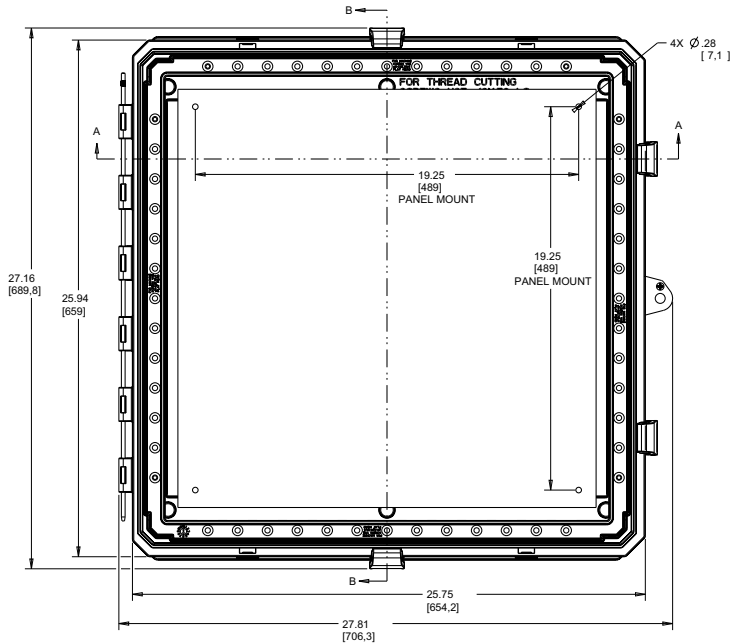

SECTION A-A

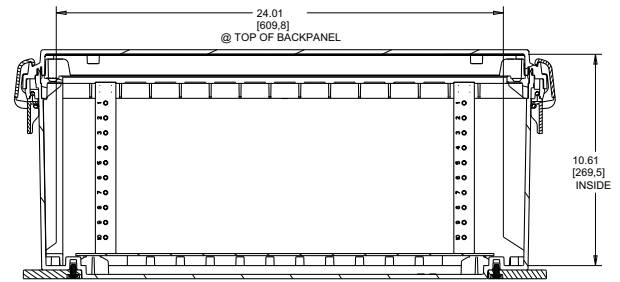

SECTION B-B

Register online to download this drawing off the Integra website at www.integraenclosures.com | Your company's logo or other information on the lid. Consult factory for details.

Accessories for 24x24x10 Genesis (For complete accessories, see page 52 & 55)

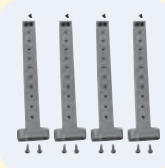

Multi-Max Rails
GMMR10 KIT - Four multi-max rails with screws included



Panel Pads
GPP KIT - Includes four panel pads and screws

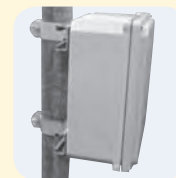

Pole Mounting Kits
PMKG-224 - 2" pole
PMKG-324 - 3" pole
PMKG-424 - 4" pole
PMKG-1224 - 12" pole



Polycarbonate Latches
GLPC KIT - Polycarbonate latches (4 per pack)



Self-Tapping Screws
GSP-10 - Self-tapping screws for bosses (10 per pack)



Swing Out Panel System
ABP2424 GSOPK - Aluminum swing panel includes ABP24 and GSOPK24
SBP2424 GSOPK - Steel swing panel includes SBP24 and GSOPK24
GSOPK24 - 24" hinge, panel pads and screws (panel not included)



Back and Swing Panels
ABP2424 - Aluminum panel
SBP2424 - Steel panel
PVCBP2424 - PVC panel

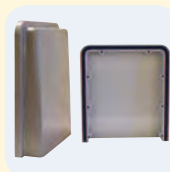

Fan Shroud Kits
FSK-1 - One shroud with gasket and screws
FSK-2 - Two shrouds with gasket and screws

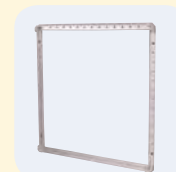

Frame Stiffener Ring
GSR2424 - Frame stiffener ring