

HIGH AIR FLOW

G1225 series

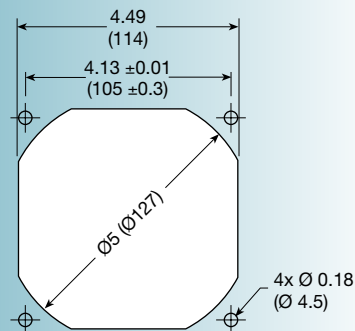
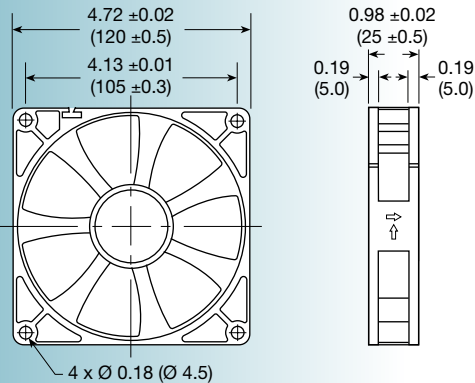

Size: (120 x 120 x 25 mm)
4.72 x 4.72 x 0.98 inches

- Features:** *high back pressure design*
- Construction:** UL94V-0 PBT impeller & frame
- Bearing option:** ball bearing
- Connection:** AWG 24, UL1007 lead wires
- Frame:** flanged
- Protection:** thermal
- Options:** tachometer output signal;
 locked rotor alarm signal;
 thermistor control;
 encapsulated motor

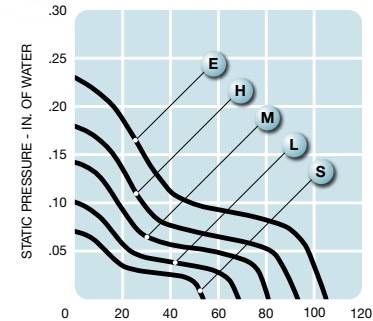

Model No.	Rated Voltage V	Current mA			Revolution RPM	Air Volume		Max. Static Pressure (H ₂)		Sound Noise dbA	Weight oz
		5	12	24		M ³ /Min.	CFM	MM	INCH		
G1225S	5/12/24	400	130	70	1,500	1.55	55	1.75	0.07	25	6.28
G1225L	5/12/24	620	230	120	1,800	1.92	68	2.50	0.10	29	6.28
G1225M	12/24	-	350	190	2,100	2.29	81	3.50	0.14	33	6.28
G1225H	12/24	-	480	270	2,400	2.63	93	4.50	0.18	37	6.28
G1225E	12/24	-	720	380	2,700	2.97	105	5.75	0.23	41	6.28