

Patch panels - FL-PP-RJ45-SC - 2901643

Please be informed that the data shown in this PDF Document is generated from our Online Catalog. Please find the complete data in the user's documentation. Our General Terms of Use for Downloads are valid (<http://download.phoenixcontact.com>)



Patch panel, one RJ45 socket to 8 screw connection terminal blocks (1:1 assignment), CAT5e, 10/100/1000 Mbps, DIN rail mounting, IP20, option of shield contacting on DIN rail via jumpers

Product Features

- Safe shield connection to ground potential
- 10/100 Mbps
- Mounting on a DIN rail
- CAT5e
- Optional shield connection via jumpers



Key commercial data

Packing unit	1 pc
Weight per Piece (excluding packing)	80.0 GRM
Custom tariff number	85369010
Country of origin	Germany

Technical data

Dimensions

Width	29 mm
Height	90 mm
Depth	53 mm

Ambient conditions

Ambient temperature (operation)	-25 °C ... 70 °C
Ambient temperature (storage/transport)	-25 °C ... 85 °C
Permissible humidity (operation)	25 % ... 95 % (non-condensing)
Degree of protection	IP20

Serial interface

Patch panels - FL-PP-RJ45-SC - 2901643

Technical data

Serial interface

Interface 1	Ethernet interface, 10/100/1000Base-T(X) according to IEEE 802.3u
Connection method	Screw connection
Transmission length	100 m (including patch cables)
Conductor cross section solid min.	0.14 mm ²
Conductor cross section solid max.	1.5 mm ²
Conductor cross section stranded min.	0.14 mm ²
Conductor cross section stranded max.	1 mm ²
Conductor cross section AWG/kcmil min.	26
Conductor cross section AWG/kcmil max.	16
Pin assignment	1:1
Serial transmission speed	10/100/1000 Mbps
Interface 2	Ethernet interface, 10/100/1000Base-T(X) according to IEEE 802.3u
Connection method	RJ45 CAT5e

General

Net weight	55 g
Housing material	PVC / PA
Color	green
MTBF	6702 Years (Telcordia standard, 25°C temperature, 21% operating cycle (5 days a week, 8 hours a day))
	2962 Years (Telcordia standard, 40°C temperature, 34.25% operating cycle (5 days a week, 12 hours a day))

Classifications

eCl@ss

eCl@ss 4.0	27250591
eCl@ss 4.1	27240409
eCl@ss 5.0	27259207
eCl@ss 5.1	27230207
eCl@ss 6.0	27230207
eCl@ss 7.0	27230207
eCl@ss 8.0	27230207

ETIM

ETIM 3.0	EC000313
ETIM 4.0	EC001128
ETIM 5.0	EC001128

Patch panels - FL-PP-RJ45-SC - 2901643

Classifications

UNSPSC

UNSPSC 6.01	30211506
UNSPSC 7.0901	39121008
UNSPSC 11	39121008
UNSPSC 12.01	39121008
UNSPSC 13.2	39121008

Approvals

Approvals

Approvals

DNV

Ex Approvals

Approvals submitted

Approval details

DNV

Accessories

Accessories

Data cable by the meter

Cable - FL CAT5 HEAVY - 2744814



CAT5-SF/UTP cable (J-02YS(ST)C HP 2 x 2 x 24 AWG), heavy-duty installation cable, 2 x 2 x 0.22 mm², solid conductor, shielded, outer sheath: 7.8 mm diameter, inner sheath: 5.75 mm ± 0.15 mm diameter

Patch panels - FL-PP-RJ45-SC - 2901643

Accessories

Network cable - FL CAT5 FLEX - 2744830



CAT5-SF/UTP cable (J-LI02YS(ST)C H 2 x 2 x 26 AWG), light-duty, flexible installation cable 2 x 2 x 0.14 mm², stranded, shielded, outer sheath: 5.75 mm ± 0.15 mm diameter

Data cable preassembled

Network cable - FL CAT5 HEAVY CONF/ - 2744827



CAT5-SF/UTP cable (J-02YS(ST)C HP 2 x 2 x 24 AWG), heavy-duty installation cable, 2 x 2 x 0.22 mm², solid conductor, shielded, outer sheath: 7.8 mm diameter, inner sheath: 5.75 mm ± 0.15 mm diameter, preassembled on both sides with RJ45 plug, crossover or line

Network cable - FL CAT5 FLEX CONF/ - 2744843



CAT5-SF/UTP cable (J-LI02YS(ST)C H 2 x 2 x 26 AWG), light-duty, flexible installation cable 2 x 2 x 0.14 mm², stranded, shielded, outer sheath: 5.75 mm ± 0.15 mm diameter, preassembled on both sides with RJ45 plug, crossover or line assignment

Data plug

RJ45 connector - VS-08-RJ45-5-Q/IP20 - 1656725



RJ45 connector, IP20, CAT5e, 8-pos., with QUICKON fast connection technology, for 26 ... 23 AWG 1-wire and 7-wire conductors, for 4.5 mm ... 8.0 mm cable diameter, labeling: TIA 568 B, color: gray

RJ45 connector - VS-08-RJ45-5-Q/IP20 BK - 1658008



RJ45 connector, IP20, CAT5e, 8-pos., with QUICKON fast connection technology, for 1-wire and 7-wire conductors AWG 26 ... 22, for cable diameter of 4.5 mm ... 8.0 mm, TIA 568 B labeling, color: black

Patch panels - FL-PP-RJ45-SC - 2901643

Accessories

Passive isolators

Network isolator - FL ISOLATOR 100-RJ/SC - 2313928



Passive network isolator for electrical isolation in Ethernet networks. This protects Ethernet devices from potential differences of up to 4 kV. Can be used for transmission speeds of up to 100 Mbps. Connection using RJ45 and COMBICON plug-in screw terminal block.

Network isolator - FL ISOLATOR 100-RJ/RJ - 2313931



Passive network isolator for electrical isolation in Ethernet networks. This protects Ethernet devices from potential differences of up to 4 kV. Can be used for transmission speeds of up to 100 Mbps. Possible to connect two RJ45 plugs.

Network isolator - FL ISOLATOR 1000-RJ/RJ - 2313915



Passive network isolator for electrical isolation in Ethernet networks. This protects Ethernet devices from potential differences of up to 4 kV. Can be used for transmission speeds of up to 1 Gbps. Possible to connect two RJ45 plugs.

Patch cable

Patch cable - FL CAT5 PATCH 0,3 - 2832250



Patch cable, CAT5, assembled, 0.3 m

Patch panels - FL-PP-RJ45-SC - 2901643

Accessories

Patch cable - FL CAT5 PATCH 0,5 - 2832263



Patch cable, CAT5, assembled, 0.5 m

Patch cable - FL CAT5 PATCH 1,0 - 2832276



Patch cable, CAT5, assembled, 1.0 m

Patch cable - FL CAT5 PATCH 1,5 - 2832221



Patch cable, CAT5, assembled, 1.5 m

Patch cable - FL CAT5 PATCH 2,0 - 2832289



Patch cable, CAT5, assembled, 2.0 m

Patch cable - FL CAT5 PATCH 3,0 - 2832292



Patch cable, CAT5, assembled, 3.0 m

Screwdriver tools

Patch panels - FL-PP-RJ45-SC - 2901643

Accessories

Screwdriver - SZF 0-0,4X2,5 - 1204504



Actuation tool, for ST terminal blocks, also suitable for use as a bladed screwdriver, size: 0.4 x 2.5 x 75 mm, 2-component grip, with non-slip grip

Universal tools

Assembly tool - FL CRIMPTOOL - 2744869



Crimping pliers, for assembling the RJ45 plugs FL PLUG RJ45..., for assembly on site

Tool - VS-CABLE-STRIP-VARIO - 1657407



Stripping tool, for the multi-level stripping of shielded cables

Additional products

Patch panels - FL-PP-RJ45-SCC - 2901642



Patch panel, one RJ45 socket to 8 spring-cage connection terminal blocks (1:1 assignment), CAT5e, 10/100/1000 Mbps, DIN rail mounting, IP20, option of shield contacting on DIN rail via jumpers

Patch panels - FL-PP-RJ45-LSA - 2901645



Patch panel, one RJ45 socket to 8 IDC connection terminal blocks (1:1 assignment), CAT5e, 10/100/1000 Mbps, DIN rail mounting, IP20, option of shield contacting on DIN rail via jumpers

Patch panels - FL-PP-RJ45-SC - 2901643

Accessories

Patch panels - FL-PP-RJ45/RJ45 - 2901646



Patch panel, two RJ45 sockets (1:1 assignment), CAT5e, 10/100/1000 Mbps, DIN rail mounting, IP20, option of shield contacting on DIN rail via jumpers

Drawings

Dimensioned drawing

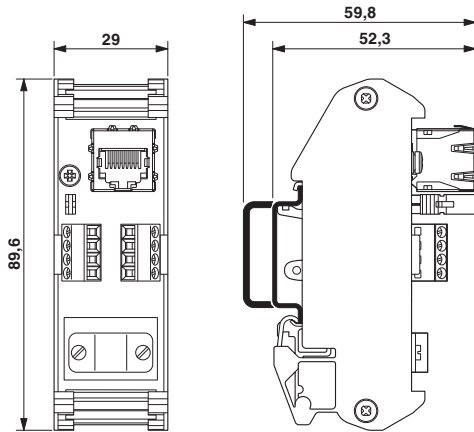

Circuit diagram

