

0.5mm Pitch FPC/FFC/Membrane

FF14A Series [Cable Lock Type]

DDK Ltd.

OUTLINE

FF14A series is a 0.9mm height connector with a cable lock mechanism, in conformity to FPC of 0.5mm pitch and 0.2mm thick. Applicable cable is 0.2mm thick FPC, FFC and membrane.

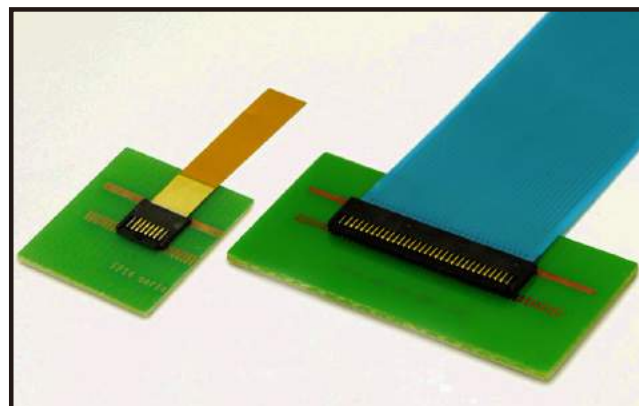

APPLICATIONS

Tablet PC, Notebook PC, PDA, Digital Camera and other portable devices

FEATURE

- ◆ FPC, FFC and membrane are mateable.
- ◆ With the upper and lower contacts design, all FPC insertion directions are available.
- ◆ DDK's original cam-type "Back-lock" system ensures reliable operation.
- ◆ DDK's cable lock mechanism provides positive retention of the FPC.
- ◆ Back-lock structure ensures retention from inadvertent upward pulling of the FPC.
- ◆ Connectors deliver with the lock lever opened. Time saving for FPC inserting operation.
- ◆ Tape and reel package for automatic mounting machine.
- ◆ High temperature resistant resin for lead free reflow process.
- ◆ Nickel barrier prevents solder wicking.

SPECIFICATIONS

Rated Voltage	50V AC (r.m.s.)
Rated Current	0.5A / Contact
Dielectric Withstand Voltage	200V AC(r.m.s.) / 1 minute
Insulation Resistance	100 M Ω min. at 500V DC
Contact Resistance	50m Ω max.

MATERIAL/FINISH



Item	Material / Finish
Contact	Copper Alloy /Au(Flash) over Ni Plating
Housing	LCP Resin (UL94V-0) / Black
Lock Lever	PPS Resin (UL94V-0) / Black

© Specifications and/or dimensions in this catalog are subject to change without notice.
Please verify the latest specifications with our drawings.

▶ FPC/FFC/Membrane Type

FF14A - □□ C-R11DL-B-3H

① ② ③ ④ ⑤ ⑥ ⑦ ⑧ ⑨ ⑩

① Series	FF14A
② Number of Contact	Please refer to Table 1
③ Contact Position	C : Upper and Lower Contact Effective mating depth : 1.15mm
④ Contact Style	R : Right Angle
⑤ Contact Tail Length	1 : 0.8mm
⑥ Contact Plating	1 : Au(Flash) over Ni plating
⑦ Lock Lever Style	D : Middle Lock Type
⑧ Nickel Barrier	L : Including
⑨ Housing Color	B : Black
⑩ Halogen Free	3H : Halogen free

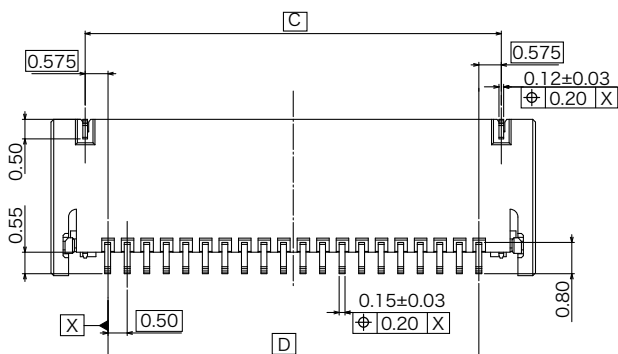
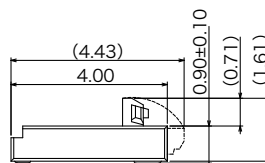
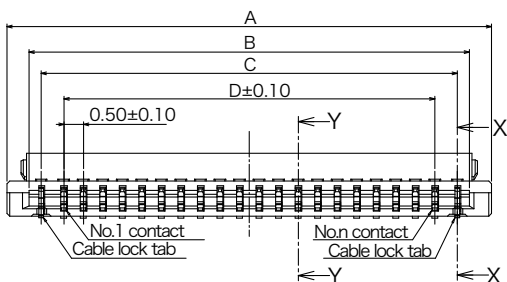
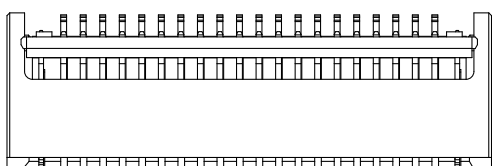

Table 1

Part Number	Number of Contact	A	B	C	D	E
FF14A - 4C - R11DL-B-3H	4	4.40	3.27	2.65	1.50	3.25
FF14A - 5C - R11DL-B-3H	5	4.90	3.77	3.15	2.00	3.75
FF14A - 6C - R11DL-B-3H	6	5.40	4.27	3.65	2.50	4.25
FF14A - 10C - R11DL-B-3H	10	7.40	6.27	5.65	4.50	6.25
FF14A - 12C - R11DL-B-3H	12	8.40	7.27	6.65	5.50	7.25
FF14A - 14C - R11DL-B-3H	14	9.40	8.27	7.65	6.50	8.25
FF14A - 18C - R11DL-B-3H	18	11.40	10.27	9.65	8.50	10.25
FF14A - 20C - R11DL-B-3H	20	12.40	11.27	10.65	9.50	11.25
FF14A - 26C - R11DL-B-3H	26	15.40	14.27	13.65	12.50	14.25
FF14A - 30C - R11DL-B-3H	30	17.40	16.27	15.65	14.50	16.25
FF14A - 40C - R11DL-B-3H	40	22.40	21.27	20.65	19.50	21.25

© Specifications and/or dimensions in this catalog are subject to change without notice.
Please verify the latest specifications with our drawings.

▶ FPC/FFC/Membrane Type

■ Recommended PCB Mounting Dimensions

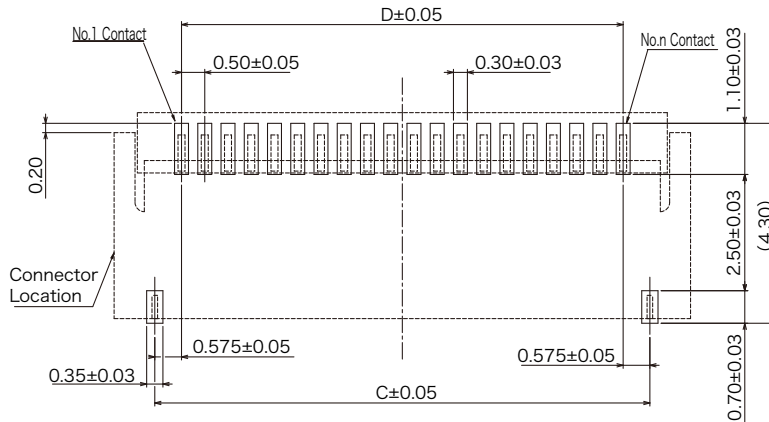

Recommended Monting Dimensions

Please refer to dimensions of C and D of Table 1.

■ Recommended Membrane, FPC and FFC Dimensions

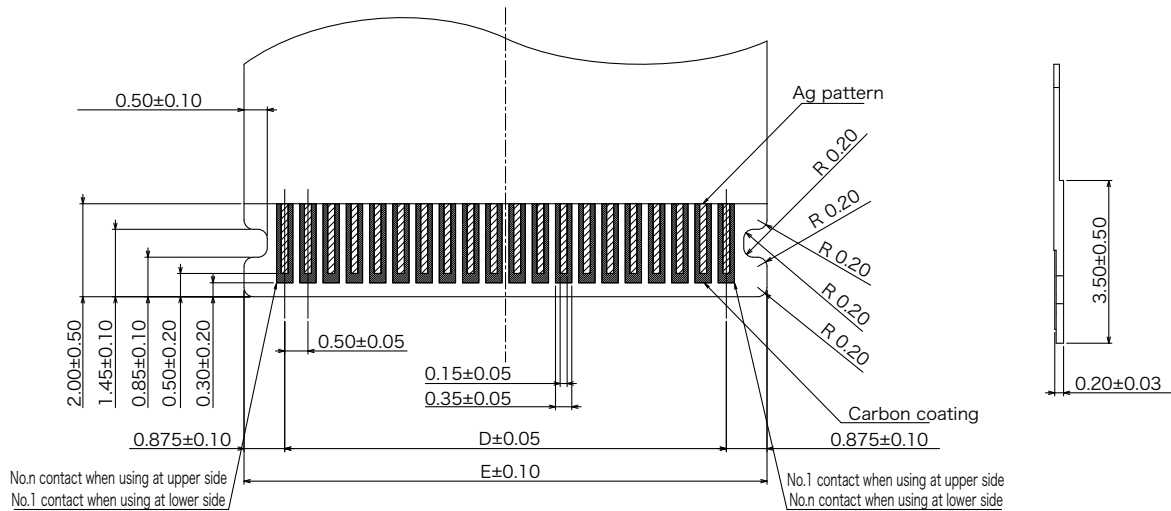

Applicable Membrane recommended dimension

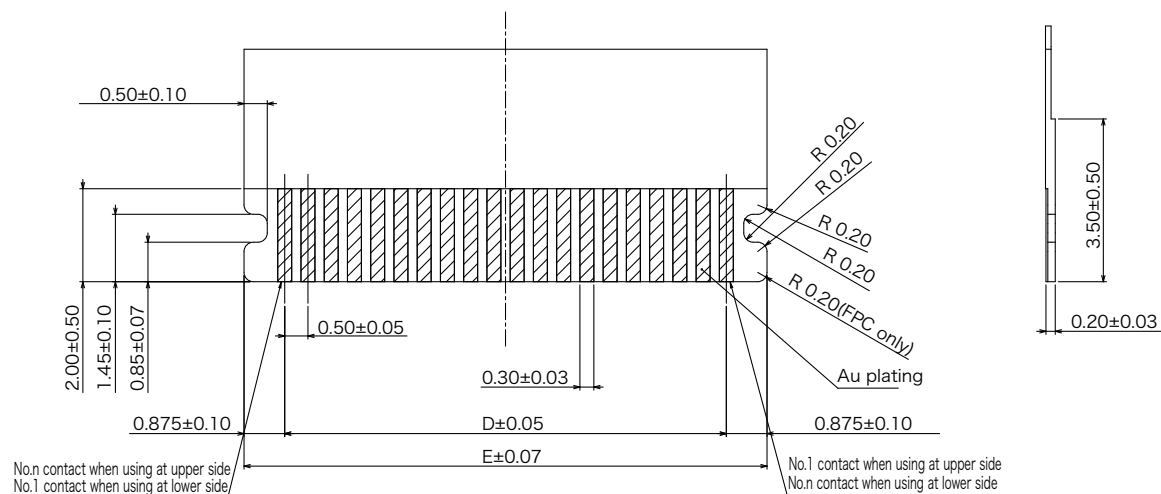

Applicable FPC+FFC recommended dimension

Please refer to dimensions of E and F of Table 1.

© Specifications and/or dimensions in this catalog are subject to change without notice.
Please verify the latest specifications with our drawings.

▶ Packing Specifications

■ Reel Dimensions

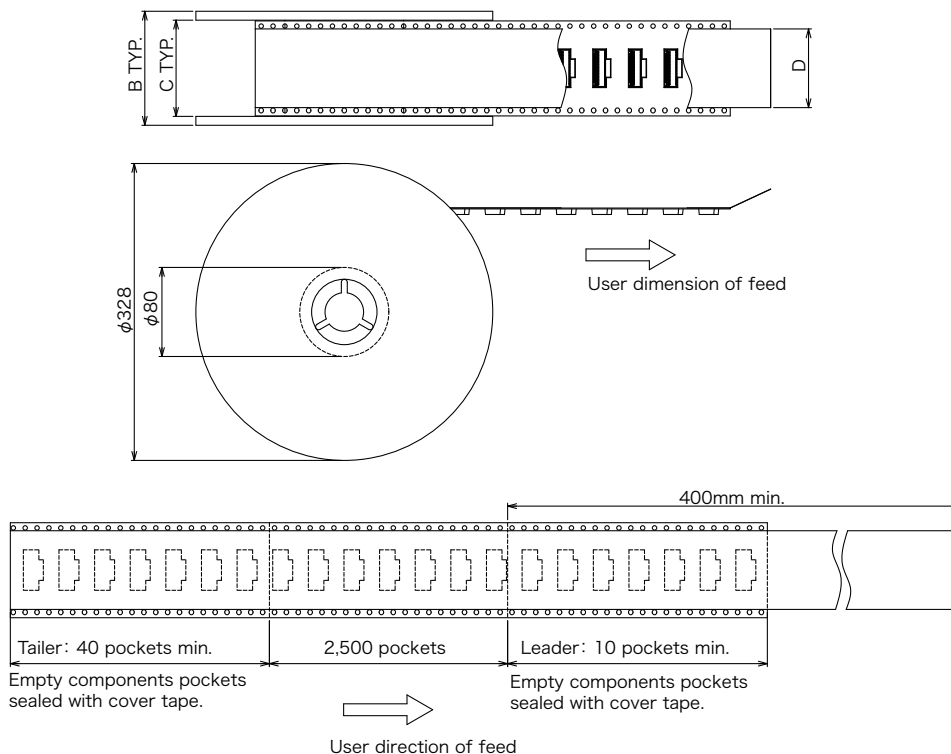

■ Tape and Reel Dimensions

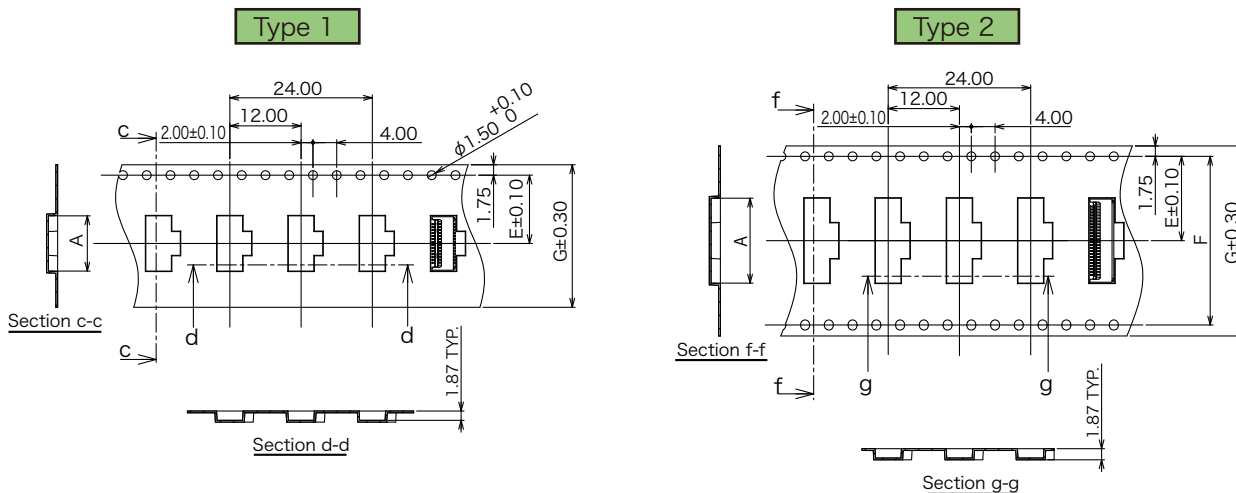

Part Number	Number of Contact	A	B	C	D	E	F	G	Tape and Reel	Quantity
FF14A-4C-R11DL-B-3H	4	4.7	30.4	24.4	21.5	11.5	—	24.0	Type 1	2,500pcs./Reel
FF14A-5C-R11DL-B-3H	5	5.2								
FF14A-6C-R11DL-B-3H	6	5.7								
FF14A-10C-R11DL-B-3H	10	7.7								
FF14A-12C-R11DL-B-3H	12	8.7								
FF14A-14C-R11DL-B-3H	14	9.7								
FF14A-18C-R11DL-B-3H	18	11.7	38.4	32.4	26.5	14.2	28.4	32.0	Type 2	
FF14A-20C-R11DL-B-3H	20	12.7								
FF14A-26C-R11DL-B-3H	26	15.7								
FF14A-30C-R11DL-B-3H	30	17.7								
FF14A-40C-R11DL-B-3H	40	22.7								

© Specifications and/or dimensions in this catalog are subject to change without notice.
Please verify the latest specifications with our drawings.

▶ Recommended Reflow Temperature profiles

■ for Leaded Solder Paste

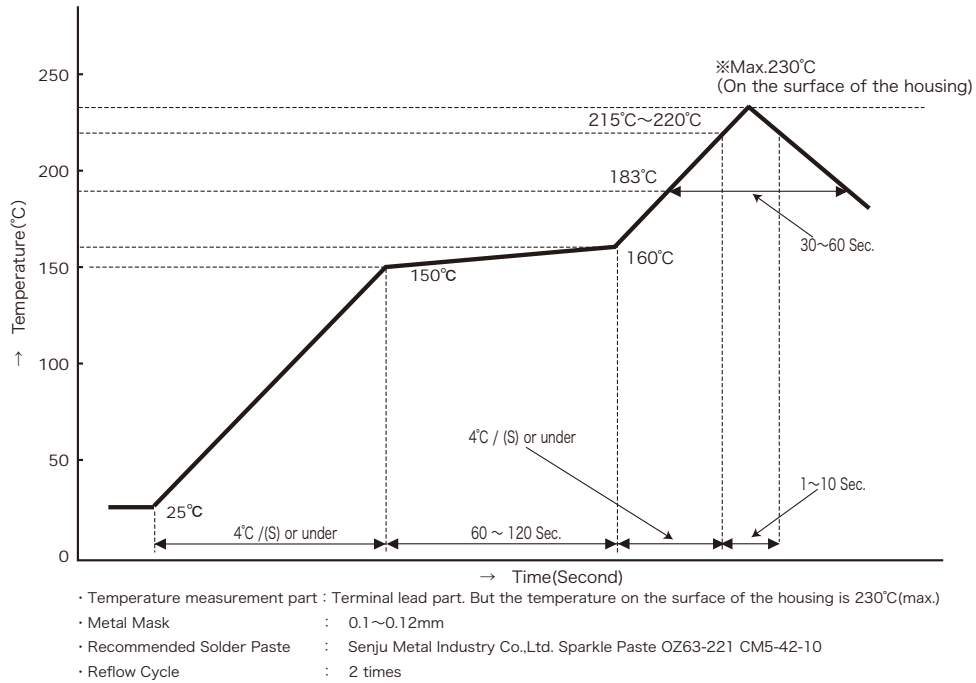

■ for Lead Free Solder Paste

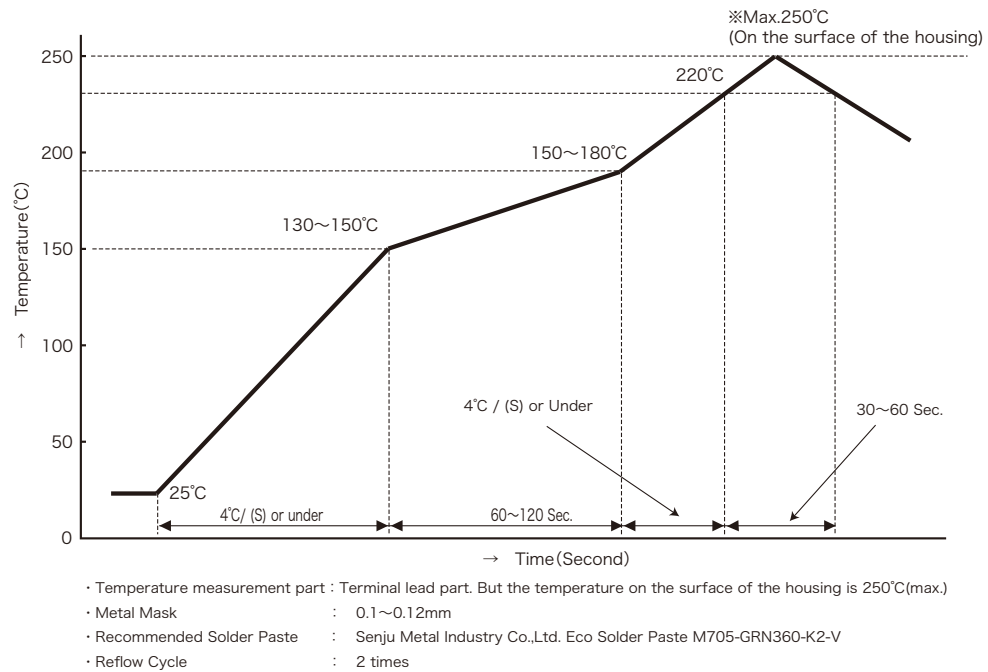

Caution

This reflow temperature profiles are reference. It may be changed the condition depend on the type of solder paste, amount of solder and flux.

Therefore, this profile does not guarantee your soldering.

© Specifications and/or dimensions in this catalog are subject to change without notice.
Please verify the latest specifications with our drawings.

▶ Operating Instruction and Cautions

1. Connector mounting Instruction

Connectors are delivered with a lock lever opened.
 You do not have to operate the lock lever before inserting FPC.
 (picture ①)

Please do not re-flow with the lock lever opened.
 Please close the lock-lever with inserting FPC, otherwise
 the contact gap become narrower and FPC insertion force will rise.
 (picture ②)

Please do not load from the top of the lock lever. (figure ①)
 And please do not load toward the opposite direction of the lock
 lever, (figure ②) otherwise the lock lever may be broken or contacts
 may be deformed.

Lock lever is opened when delivery.

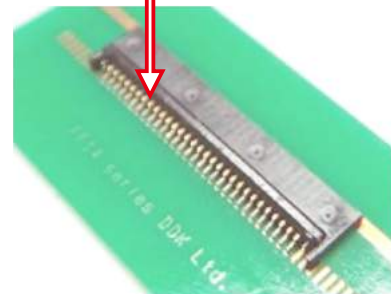

picture ①

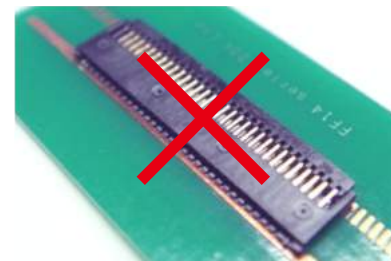

picture ②

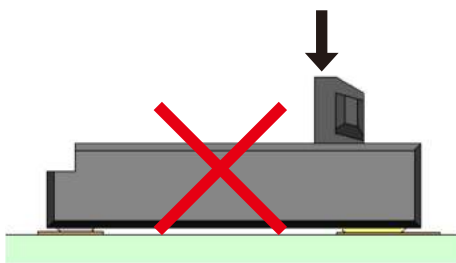

figure ①

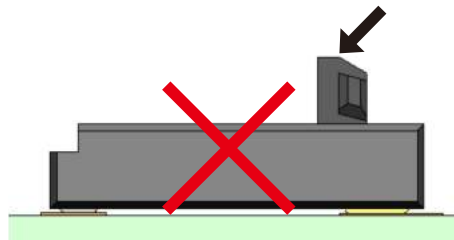
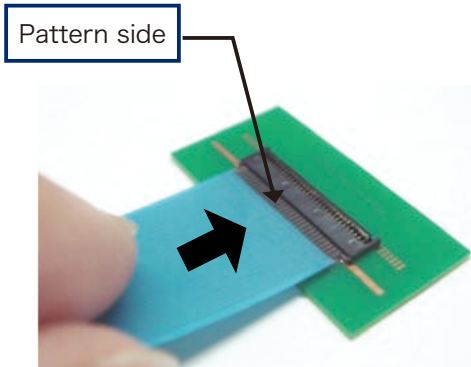

figure ②

2. FPC Insertion

Please insert FPC to the pattern side up.(picture ③) when using upper contacts.
 Please insert FPC to the stiffener side up.(picture ④) when using lower contacts.

Please insert FPC straight to the connector.
 Due to the semi-retainig mechanism,
 some insertion force is necessary when inserting FPC.
 Please make sure whether FPC is inserted fully.



picture ③

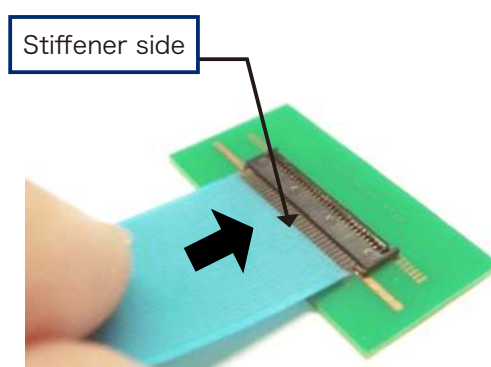

picture ④

© Specifications and/or dimensions in this catalog are subject to change without notice.
 Please verify the latest specifications with our drawings.

▶ Operating Instruction and Cautions

3. Correct FPC Insertion Position

3-1. Upper Contact

As illustrated (picture ⑤), you can check short insertion (picture ⑥) and diagonal insertion (picture ⑦) by checking the position of connector housing and FPC positioning edge.

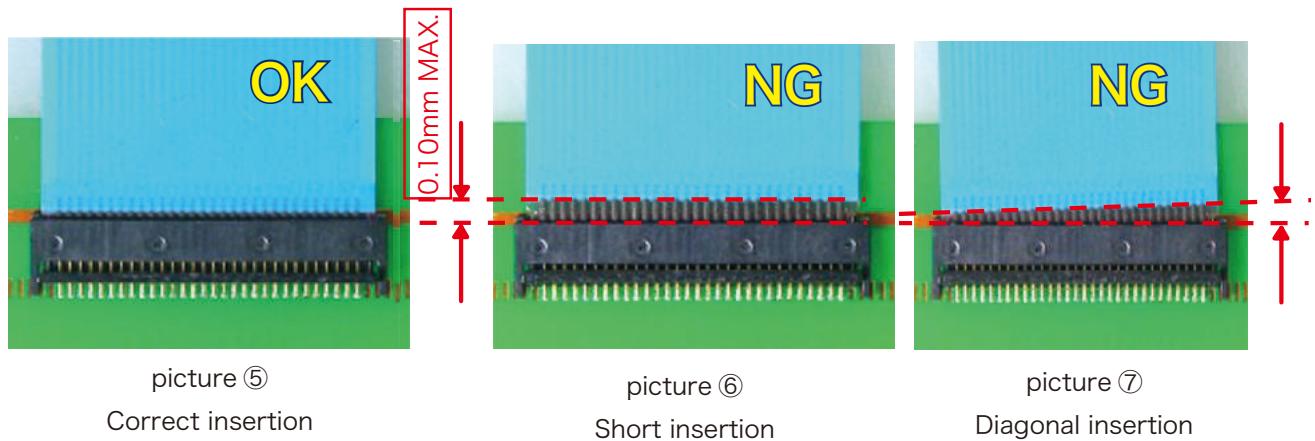

3-2. Lower Contact

As illustrated (picture ⑧ and ⑨), if the FPC positioning edge is exposed from the connector housing,

it may be short insertion or diagonal insertion. Please re-insert FPC fully.

And draw the line parallel to FPC. Then you can check the short insertion same as illustration 3-1.

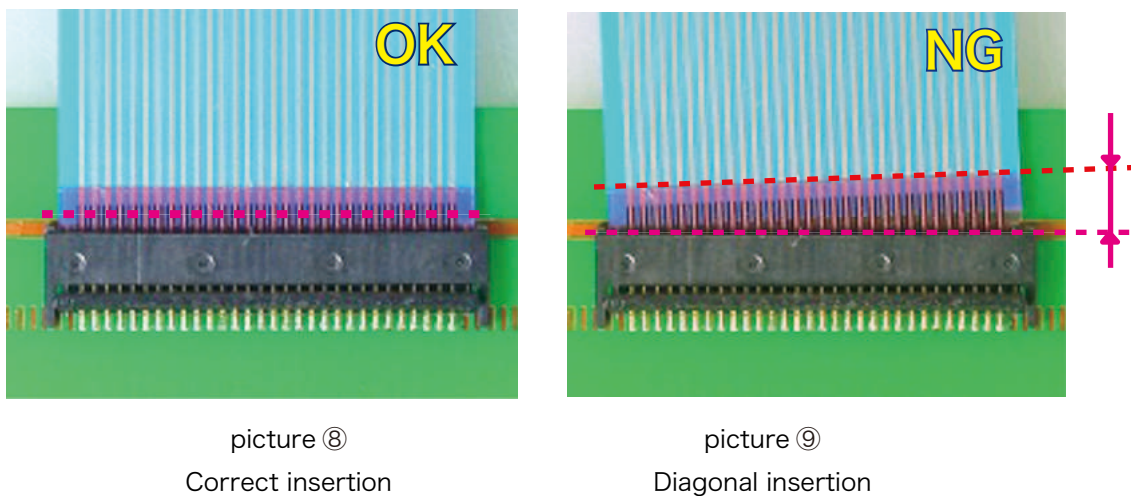

© Specifications and/or dimensions in this catalog are subject to change without notice.
Please verify the latest specifications with our drawings.

▶ Operating Instruction and Cautions

4. Closing Lock Lever

Please rotate down the lock lever until firmly closed. (picture ⑩)

Please do not load excessive force on the housing (picture ⑪)

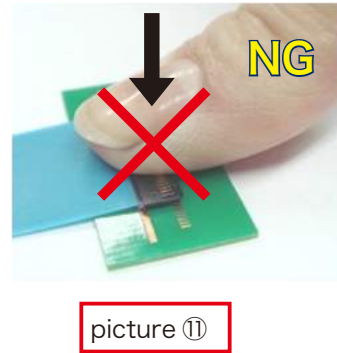
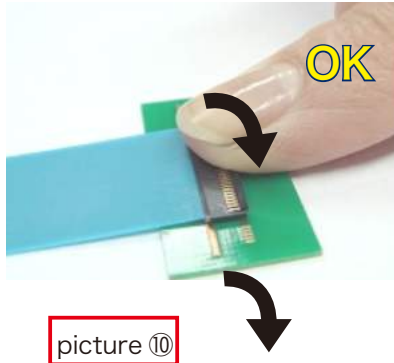

Please do not close the lock lever by tip of a nail. (picture ⑫)

It may cause breakage of the lock lever.

When you close the lock lever, please hold more than 5mm width. (picture ⑬)

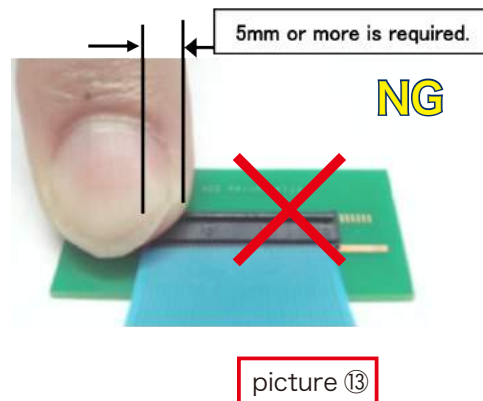
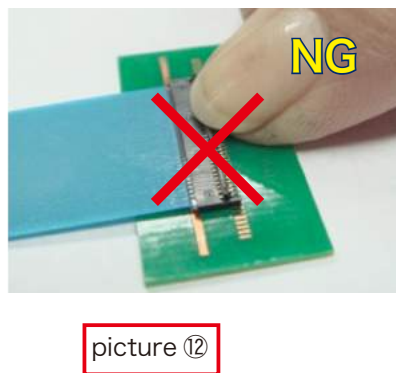

5. Removing FPC

Please lift the lock lever like flipping up in the direction of arrow. (picture ⑭)

Please do not load excessive force on the lock lever. (picture ⑮)

When operating the lock lever, please make sure to not catch to the connector housing. It may cause breakage of the housing.

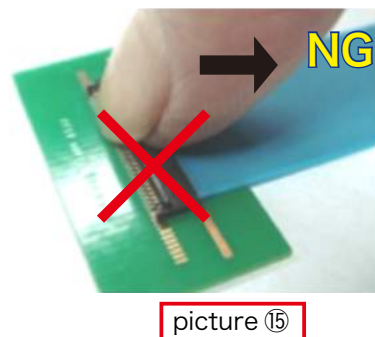
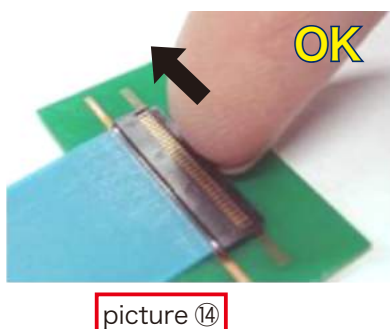

6. ESD (Electrostatic Discharge)

This connector is not taken ESD measure.

© Specifications and/or dimensions in this catalog are subject to change without notice.
Please verify the latest specifications with our drawings.