

# Earth Leakage Circuit Breakers

## List of products

### ■ G-TWIN Standard Series (IEC/EN/GB/JIS conformed)

#### Line protection

##### • 2-pole

AC230V (Icu)	EW32	EW50	EW100
2.5kA	AAG-2P	AAG-2P	
10kA			EAG-2P

##### • 3-pole

AC415V (Icu)	EW32	EW50	EW63	EW100	EW125	EW160	EW250	EW400	EW630	EW800
1.5kA	EAG-3P									
2.5kA	SAG-3P	EAG-3P	EAG-3P							
7.5kA		SAG-3P	SAG-3P							
10kA		RAG-3P	RAG-3P	EAG-3P						
18kA						EAG-3P	EAG-3P			
30kA					JAG-3P	JAG-3P	JAG-3P	EAG-3P		
36kA					SAG-3P	SAG-3P	SAG-3P	SAG-3P	EAG-3P	EAG-3P
50kA					RAG-3P	RAG-3P	RAG-3P	RAG-3P	RAG-3P	RAG-3P
70kA								HAG-3P	HAG-3P	HAG-3P

##### • 4-pole

AC415V (Icu)	EW125	EW160	EW250	EW400
30kA	JAG-4P	JAG-4P	JAG-4P	
36kA	SAG-4P	SAG-4P	SAG-4P	
50kA	RAG-4P	RAG-4P	RAG-4P	RAG-4P
70kA				HAG-4P

#### Motor protection

##### • 3-pole

AC415V (Icu)	EW32	EW50	EW63	EW100	EW125	EW250
1.5kA	EAM-3P					
2.5kA	SAM-3P	EAM-3P	EAM-3P			
7.5kA		SAM-3P	SAM-3P			
10kA				EAM-3P		
18kA						EAM-3P
30kA					JAM-3P	JAM-3P
50kA					RAM-3P	RAM-3P

### ■ G-TWIN Global Series (IEC/EN/GB/JIS/UL/CSA conformed)

#### Line protection

##### • 2-pole

AC230V (Icu)	EW100
10kA	EAGU-2P

##### • 3-pole

AC415V (Icu)	EW50	EW100	EW125	EW250	EW400	EW630
10kA	RAGU-3P	EAGU-3P				
30kA			JAGU-3P	JAGU-3P		
36kA					SAGU-3P	
50kA			RAGU-3P	RAGU-3P	RAGU-3P	RAGU-3P
70kA					HAGU-3P	

### ■ HG Series

#### Line protection (3-pole)

AC415V (Icu)	50AF	100AF	225AF
65kA	HG53B	HG103B	HG203B

# Earth Leakage Circuit Breakers

## G-TWIN series

### Type number nomenclature

#### ■ Type number nomenclature

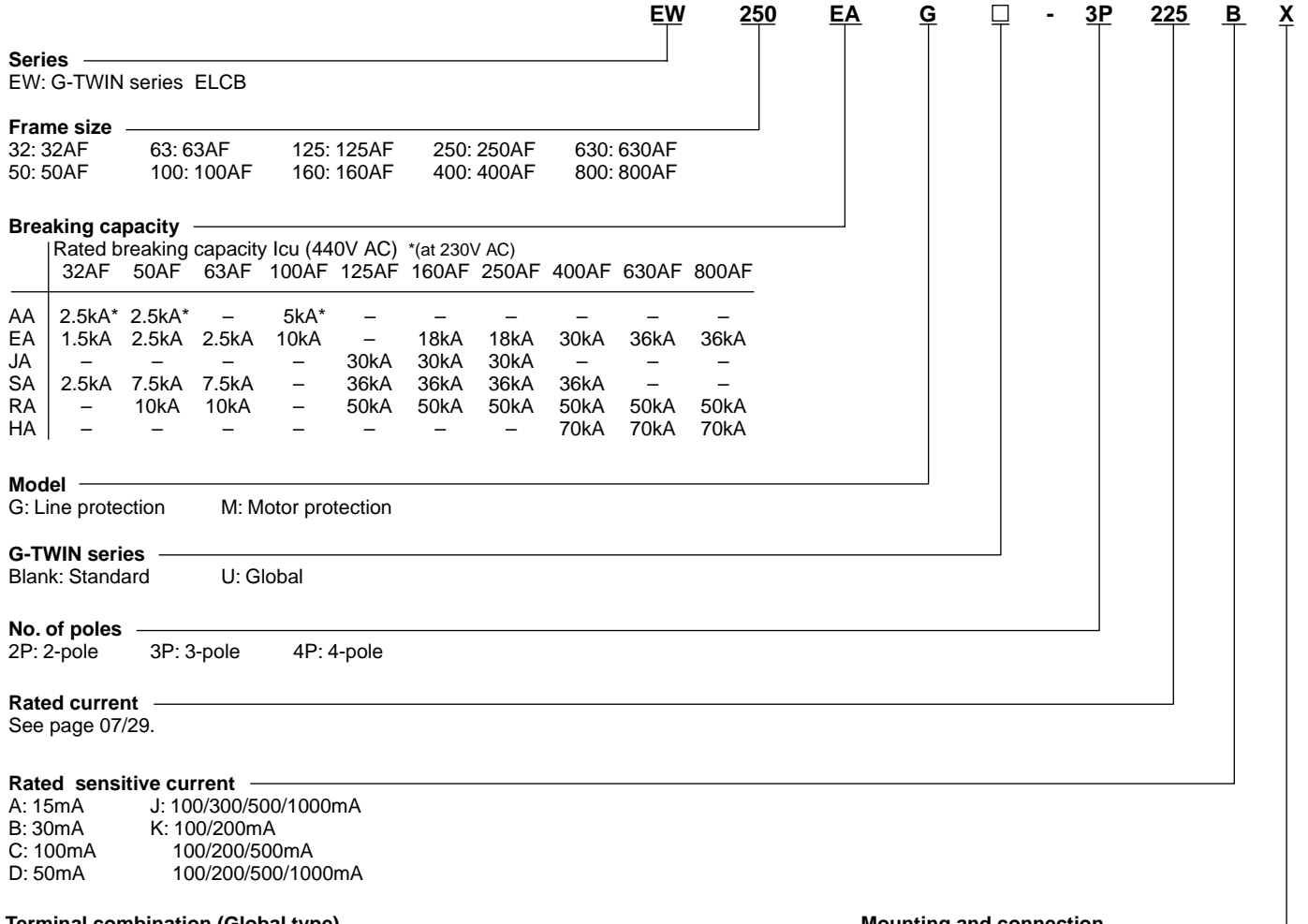

#### Terminal combination (Global type)

Code	Terminal position		Applicable breaker type		
	Line	Load	EW50, 100	EW125, 250	EW400, 630
Blank	Screw	Screw	●	●	—
Blank	Flat terminal	Flat terminal	—	—	●
SB	Block terminal	Block terminal	—	●	●
SF	Flat terminal	Flat terminal	●	●	—
S3	Screw	Flat terminal	●	●	—
S4	Flat terminal	Screw	●	●	—
S5	Screw	Block terminal	—	●	—
S6	Block terminal	Screw	—	●	—
S7	Flat terminal	Block terminal	—	●	●
S8	Block terminal	Flat terminal	—	●	●

#### Mounting and connection

##### • Standard type

- Blank: Front mounting, front connection
- X: Front mounting, rear connection
- E: Flush mounting, rear connection
- Y: Flush mounting, top & bottom connection
- P: Plug-in mounting

# Earth Leakage Circuit Breakers

## G-TWIN series

### Type number nomenclature

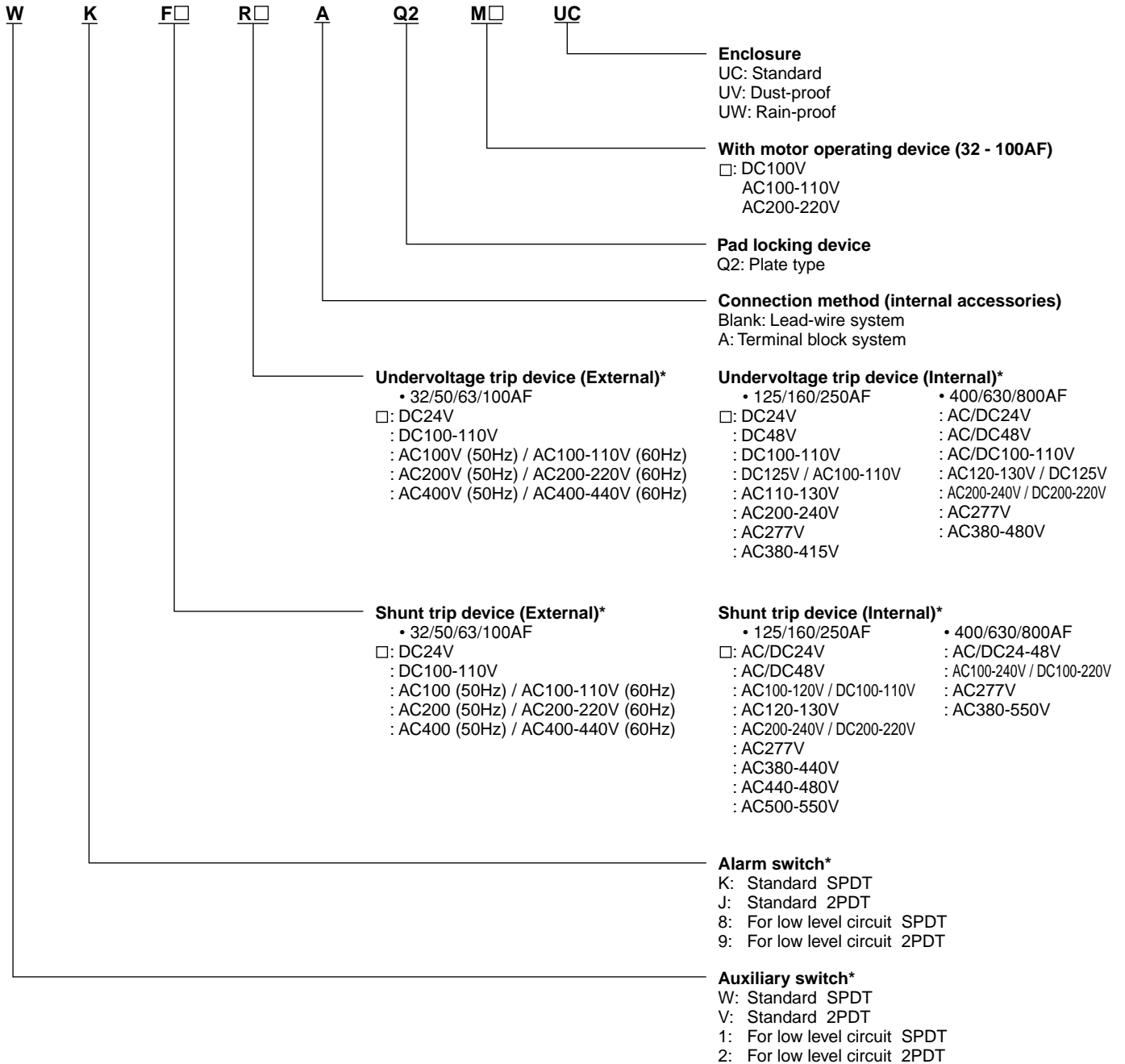

\* For the available configuration of accessory, see page 07/62.

# Earth Leakage Circuit Breakers

## G-TWIN series

### Quick reference guide

#### ■ G-TWIN Standard Series

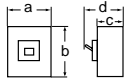
Ampere frame			32A				
Type			EW32AAG		EW32EAG	EW32SAG	
Pole			2	3	3	3	
Rated current	Reference amb. temp. (40°C)	In(A)	5, 10, 15, 20, 30, 32	5, 10, 15, 20, 30, 32	5, 10, 15, 20, 30, 32	3, 5, 10, 15, 20, 30, 32	
Rated impulse withstand voltage			Uimp(kV)		2.5	4	
Isolation compliant			●	●	●	●	
Rated voltage Ue (AC V)			100-230	100-230	100-230-440	100-230-440	
Rated sensitive current (mA)			15, 30, 100	15, 30, 100	15, 30, 100	30, 100/200/500 changeover	
Tripping time (s)			0.1 or less	0.1 or less	0.1 or less	0.1 or less	
Rated breaking capacity Icu/Ics (kA)	IEC 60947-2 EN 60947-2 JIS C 8201-2-2	AC	440V	–	–	1.5/1	2.5/2
			415V	–	–	1.5/1	2.5/2
			400V	–	–	1.5/1	2.5/2
			380V	–	–	1.5/1	2.5/2
			230V	2.5/2	2.5/2	2.5/2	5/3
			200V	2.5/2	2.5/2	2.5/2	5/3
			100V	2.5/2	5/3	5/3	5/3
	GB14048.2	AC	400V	–	–	1.5/1	2.5/2
230V	2.5/2	2.5/2	2.5/2	5/3			
Conforming to standards	CE Marking		● (TÜV)	● (TÜV)	● (TÜV)	● (TÜV)	
	CCC certificate		●	●	●	●	
	Electrical Appliance and Material Safety Law *1		●	●	●	●	
Dimensions (mm)			a	50	75	75	75
			b	100		100	100
			c	60		60	60
			d	84		84	84
Mass (kg)			0.4	0.5	0.5	0.6	
Tripping device			Hydraulic-magnetic				
Front mounting, front connection			No-mark	○	○	○	○
Front mounting, rear connection			X	○	○	○	○
Flush mounting, front connection			E	○	○	○	○
Flush mounting, top & bottom connection			Y	○	○	○	○
Plug-in mounting			P	○	○	○	○
IEC 35mm wide rail mounting			No-mark	○	○	○	○
Internal accessories			Page 07/57				
Alarm switch			K	○	○	○	○
Auxiliary switch			W	○	○	○	○
Undervoltage trip			R	○	○	○	○
Shunt trip			F	○	○	○	○
Earth alarm switch			L	–	–	–	–
External accessories			Page 07/60				
Handle padlocking device Cap type			QN	○	○	○	○
Handle padlocking device Plate type			Q2	▲	▲	▲	▲
Operating handle N-type			N	○	○	○	○
Operating handle V-type			V	○	○	○	○
Terminal cover Short			BT□S	○	○	○	○
Terminal cover Long			BT□L	○	○	○	○
Insulation barrier Interphase			BP	○	○	○	○
Earth			BL	○	○	○	○
Handle locking cover			L1	○	○	○	○
Flat terminal			SS	○	○	○	○
Block terminal			SL	–	–	–	–

●: Approved ○: Available –: Not available ▲: Factory-mounted accessory  
 Note: \*1 Electrical Appliance and Material Safety Law of Japan

Rated voltage (V)	Operational voltage range (V)
100–230	80–264
100–230–440	80–484

# Earth Leakage Circuit Breakers

## G-TWIN series

### Quick reference guide

#### ■ G-TWIN Standard Series

Ampere frame			50A						
Type			EW50AAG		EW50EAG	EW50SAG	EW50RAG		
Pole			2	3	3	3	3		
Rated current	Reference amb. temp. (40°C)	In(A)	5, 10, 15, 20, 30, 32, 40, 50		5, 10, 15, 20, 30, 32, 40, 50		5, 10, 15, 20, 30, 32, 40, 50		
Rated impulse withstand voltage			Uimp(kV)		2.5	4	6	6	
Isolation compliant			●		●	●	●		
Rated voltage Ue (AC V)			100-230		100-230-440		100-230-440		
Rated sensitive current (mA)			15, 30, 100		15, 30, 100/200 changeover		30, 100/200/500 changeover		
Tripping time (s)			0.1 or less		0.1 or less		0.1 or less		
Rated breaking capacity Icu/Ics (kA)	IEC 60947-2 EN 60947-2 JIS C 8201-2-2	AC	440V	-		2.5/2		7.5/4	
			415V	-		2.5/2		7.5/4	
			400V	-		2.5/2		7.5/4	
			380V	-		2.5/2		7.5/4	
			230V	2.5/2		5/3		10/5	
			200V	2.5/2		5/3		10/5	
			100V	2.5/2		5/3		10/5	
	GB14048.2	AC	400V	-		2.5/2		7.5/4	
			230V	2.5/2		5/3		10/5	
			230V	2.5/2		5/3		10/5	
Conforming to standards			CE Marking		● (TÜV)		● (TÜV)		
			CCC certificate		●		●		
			Electrical Appliance and Material Safety Law *1		●		●		
Dimensions (mm)				a	50	75	75	75	
				b	100		100	100	
				c	60		60	60	
				d	84		84	84	
Mass (kg)			0.4	0.6	0.6	0.6	0.6		
Tripping device			Hydraulic-magnetic						
Front mounting, front connection			No-mark	○	○	○	○		
Front mounting, rear connection			X	○	○	○	○		
Flush mounting, front connection			E	○	○	○	○		
Flush mounting, top & bottom connection			Y	○	○	○	○		
Plug-in mounting			P	○	○	○	○		
IEC 35mm wide rail mounting			No-mark	○	○	○	○		
Internal accessories			Page 07/57						
Alarm switch			K	○	○	○	○		
Auxiliary switch			W	○	○	○	○		
Undervoltage trip			R	○	○	○	○		
Shunt trip			F	○	○	○	○		
Earth alarm switch			L	-	-	-	-		
External accessories			Page 07/60						
Handle padlocking device Cap type			QN	○	○	○	○		
Handle padlocking device Plate type			Q2	▲	▲	▲	▲		
Operating handle N-type			N	○	○	○	○		
Operating handle V-type			V	○	○	○	○		
Terminal cover Short			BT□S	○	○	○	○		
Terminal cover Long			BT□L	○	○	○	○		
Insulation barrier Interphase			BP	○	○	○	○		
Insulation barrier Earth			BL	○	○	○	○		
Handle locking cover			L1	○	○	○	○		
Flat terminal			SS	○	○	○	○		
Block terminal			SL	-	-	-	-		

●: Approved ○: Available -: Not available ▲: Factory-mounted accessory  
 Note: \*1 Electrical Appliance and Material Safety Law of Japan

Rated voltage (V)	Operational voltage range (V)
100-230	80-264
100-230-440	80-484

07

# Earth Leakage Circuit Breakers

## G-TWIN series

### Quick reference guide

#### ■ G-TWIN Standard Series

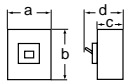
Ampere frame		63A				
Type		EW63EAG	EW63SAG	EW63RAG		
Pole		3	3	3		
Rated current	Reference amb. temp. (40°C)	In(A)	60, 63	60, 63		
Rated impulse withstand voltage		Uimp(kV)	6	6		
Isolation compliant			●	●		
Rated voltage Ue (AC V)			100-230-440	100-230-440		
Rated sensitive current (mA)			15, 30, 100/200 changeover	30, 100/200/500 changeover		
Tripping time (s)			0.1 or less	0.1 or less		
Rated breaking capacity Icu/Ics (kA)	IEC 60947-2 EN 60947-2 JIS C 8201-2-2	AC	440V	2.5/2	7.5/4	10/5
			415V	2.5/2	7.5/4	10/5
			400V	2.5/2	7.5/4	10/5
			380V	2.5/2	7.5/4	10/5
			230V	5/3	10/5	25/13
			200V	5/3	10/5	25/13
			100V	5/3	10/5	25/13
	GB14048.2	AC	400V	2.5/2	7.5/4	10/5
			230V	5/3	10/5	25/13
Conforming to standards	CE Marking		● (TÜV)	● (TÜV)	● (TÜV)	
	CCC certificate		●	●	●	
	Electrical Appliance and Material Safety Law *1		●	●	●	
Dimensions (mm)		a	75	75	75	
		b	100	100	100	
		c	60	60	60	
		d	84	84	84	
Mass (kg)			0.6	0.6	0.6	
Tripping device			Hydraulic-magnetic			
Front mounting, front connection	No-mark	○	○	○		
Front mounting, rear connection	X	○	○	○		
Flush mounting, front connection	E	○	○	○		
Flush mounting, top & bottom connection	Y	○	○	○		
Plug-in mounting	P	○	○	○		
IEC 35mm wide rail mounting	No-mark	○	○	○		
Internal accessories		Page 07/57				
Alarm switch	K	○	○	○		
Auxiliary switch	W	○	○	○		
Undervoltage trip	R	○	○	○		
Shunt trip	F	○	○	○		
Earth alarm switch	L	-	-	-		
External accessories		Page 07/60				
Handle padlocking device	Cap type	QN	○	○		
Handle padlocking device	Plate type	Q2	▲	▲		
Operating handle	N-type	N	○	○		
Operating handle	V-type	V	○	○		
Terminal cover	Short	BTQS	○	○		
Terminal cover	Long	BTQL	○	○		
Insulation barrier	Interphase	BP	○	○		
	Earth	BL	○	○		
Handle locking cover		L1	○	○		
Flat terminal		SS	○	○		
Block terminal		SL	-	-		

●: Approved ○: Available -: Not available ▲: Factory-mounted accessory  
 Note: \*1 Electrical Appliance and Material Safety Law of Japan

Rated voltage (V)	Operational voltage range (V)
100-230	80-264
100-230-440	80-484

# Earth Leakage Circuit Breakers

## G-TWIN series

### Quick reference guide

#### ■ G-TWIN Standard Series

Ampere frame			100A			
Type			EW100AAG		EW100EAG	
Pole			3	2	3	
Rated current	Reference amb. temp. (40°C)	In(A)	60, 63, 75, 100		50, 60, 63, 75, 100	
Rated impulse withstand voltage		Uimp(kV)	4		6	
Isolation compliant			●		●	
Rated voltage Ue (AC V)			100-230		100-230	
Rated sensitive current (mA)			30, 100/200/500 changeover		30, 100/200 changeover	
Tripping time (s)			0.1 or less		0.1 or less	
Rated breaking capacity Icu/Ics (kA)	IEC 60947-2 EN 60947-2 JIS C 8201-2-2	AC	440V	-		10/5
			415V	-		10/5
			400V	-		10/5
			380V	-		10/5
			230V	5/3	10/5	25/13
			200V	5/3	10/5	25/13
			100V	5/3	10/5	25/13
	GB14048.2	AC	400V	-		10/5
			230V	5/3	10/5	25/13
Conforming to standards			CE Marking	● (TÜV)		
			CCC certificate	●		
			Electrical Appliance and Material Safety Law *1	●		
Dimensions (mm)				a	75	75
				b	100	100
				c	60	60
				d	84	84
				Mass (kg)	0.6	
Tripping device			Thermal -magnetic			
Front mounting, front connection			No-mark	○	○	
Front mounting, rear connection			X	○	○	
Flush mounting, front connection			E	○	○	
Flush mounting, top & bottom connection			Y	○	○	
Plug-in mounting			P	○	○	
IEC 35mm wide rail mounting			No-mark	○	○	
Internal accessories			Page 07/57			
Alarm switch			K	○	○	
Auxiliary switch			W	○	○	
Undervoltage trip			R	○	○	
Shunt trip			F	○	○	
Earth alarm switch			L	-	-	
External accessories			Page 07/60			
Handle padlocking device Cap type			QN	○	○	
Handle padlocking device Plate type			Q2	▲	▲	
Operating handle N-type			N	○	○	
Operating handle V-type			V	○	○	
Terminal cover Short			BT□S	○	○	
Terminal cover Long			BT□L	○	○	
Insulation barrier Interphase			BP	○	○	
Insulation barrier Earth			BL	○	○	
Handle locking cover			L1	○	○	
Flat terminal			SS	○	○	
Block terminal			SL	-	-	

●: Approved ○: Available -: Not available ▲: Factory-mounted accessory  
 Note: \*1 Electrical Appliance and Material Safety Law of Japan

Rated voltage (V)	Operational voltage range (V)
100-230	80-264
100-230-440	80-484

# Earth Leakage Circuit Breakers

## G-TWIN series

### Quick reference guide

#### ■ G-TWIN Standard Series

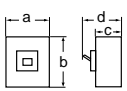
Ampere frame		125A						
Type		EW125JAG		EW125SAG		EW125RAG		
Pole		3	4	3	4	3	4	
Rated current	Reference amb. temp. (40°C)	In(A) 15, 20, 30, 40, 50, 60, 75, 100, 125						
Rated impulse withstand voltage		Uimp(kV) 6		6		6		
Isolation compliant		●		●		●		
Rated voltage Ue (AC V)		100-230-440						
Type of earth leakage trip action		AC type						
Instantaneous trip type	Rated sensitive current (mA)	30						
	Tripping time (s)	0.1 or less						
Instantaneous/time-delay trip type	Rated sensitive current (mA)	100/300/500/1000 changeover						
	Tripping time (s)	0.1/0.4/1/2 changeover						
	Inertia non-tripping time (s) (2IΔn)	0/0.2/0.5/1						
Rated breaking capacity Icu/Ics (kA)	IEC60947-2 EN60947-2 JISC8201-2-2	AC	440V	30/15	36/18	50/25		
			415V	30/15	36/18	50/25		
			400V	30/15	36/18	50/25		
			380V	30/15	36/18	50/25		
			230V	50/25	85/43	100/50		
			200V	50/25	85/43	100/50		
			100V	50/25	85/43	100/50		
	GB14048.2	AC	400V	30/15	36/18	50/25		
			230V	50/25	85/43	100/50		
			230V	50/25	85/43	100/50		
Conforming to standards	CE Marking		● (TÜV)		● (TÜV)			
	CCC certificate		●		●			
	Electrical Appliance and Material Safety Law *1		● (except for 125A)		● (except for 125A)			
Dimensions (mm)		a	90	120	90	120	90	120
		b	155		155		155	
		c	68		68		68	
		d	95		95		95	
		Mass (kg)	1.3	1.7	1.2	1.6	1.3	1.7
Tripping device		Thermal-magnetic						
Front mounting, front connection	No-mark	○	○	○	○	○	○	
Front mounting, rear connection	X	○	○	○	○	○	○	
Flush mounting, front connection	E	○	○	○	○	○	○	
Plug-in mounting	P	○	—	○	—	○	—	
Internal accessories Page 07/58								
Alarm switch	K	○	○	○	○	○	○	
Auxiliary switch	W	○	○	○	○	○	○	
Undervoltage trip	R	○	○	○	○	○	○	
Shunt trip	F	○	○	○	○	○	○	
Earth alarm switch	L	○	○	○	○	○	○	
External accessories Page 07/60								
Handle padlocking device	Cap type Q1	○	○	○	○	○	○	
Handle padlocking device	Plate type Q2	○	○	○	○	○	○	
Operating handle	N-type N	○	○	○	○	○	○	
Operating handle	V-type V	○	○	○	○	○	○	
Terminal cover	Short BTCS	○	○	○	○	○	○	
Terminal cover	Long BTCL	○	○	○	○	○	○	
Insulation barrier	Interphase BP	○	○	○	○	○	○	
Handle locking cover	L1	○	○	○	○	○	○	
Flat terminal	SS	○	○	○	○	○	○	
Block terminal	SL	○	○	○	○	○	○	

●: Approved ○: Available —: Not available ▲: Factory-mounted accessory  
 Note: \*1 Electrical Appliance and Material Safety Law of Japan

Rated voltage (V)	Operational voltage range (V)
100-230-440	80-484



# Earth Leakage Circuit Breakers

## G-TWIN series

### Quick reference guide

#### ■ G-TWIN Standard Series

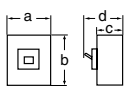
Ampere frame			160A									
Type			EW160EAG		EW160JAG		EW160SAG		EW160RAG			
Pole			3		3		4		3		4	
Rated current Reference amb. temp. (40°C) In(A)			125, 150, 160									
Rated impulse withstand voltage Uimp(kV)			6		6		6		6			
Isolation compliant			●		●		●		●			
Rated voltage Ue (AC V)			100-230-440									
Type of earth leakage trip action			AC type									
Instantaneous trip type	Rated sensitive current (mA)		30									
	Tripping time (s)		0.1 or less									
Instantaneous/time-delay trip type	Rated sensitive current (mA)		100/300/500/1000 changeover									
	Tripping time (s)		0.1/0.4/1/2 changeover									
	Inertia non-tripping time (s) (2IΔn)		0/0.2/0.5/1									
Rated breaking capacity Icu/Ics (kA)	IEC60947-2 EN60947-2 JISC8201-2-2	AC	440V	18/9	30/15	36/18	50/25					
			415V	18/9	30/15	36/18	50/25					
			400V	18/9	30/15	36/18	50/25					
			380V	18/9	30/15	36/18	50/25					
			230V	36/18	50/25	85/43	100/50					
			200V	36/18	50/25	85/43	100/50					
			100V	36/18	50/25	85/43	100/50					
	GB14048.2	AC	400V	18/9	30/15	36/18	50/25					
			230V	36/18	50/25	85/43	100/50					
Conforming to standards	CE Marking certified (TÜV)		● (TÜV)		● (TÜV)		● (TÜV)		● (TÜV)			
	CCC certificate		●		●		●		●			
Dimensions (mm)		a	105	105	140	105	140	105	140			
		b	165	165		165		165				
		c	68	68		68		68				
		d	95	95		95		95				
Mass (kg)			1.8	1.8	2.3	1.8	2.3	1.8	2.3			
Tripping device			Thermal-magnetic									
Front mounting, front connection	No-mark	○	○	○	○	○	○	○	○			
Front mounting, rear connection	X	○	○	○	○	○	○	○	○			
Flush mounting, front connection	E	○	○	○	○	○	○	○	○			
Plug-in mounting	P	○	○	—	○	—	○	○	—			
Internal accessories Page 07/58												
Alarm switch	K	○	○	○	○	○	○	○	○			
Auxiliary switch	W	○	○	○	○	○	○	○	○			
Undervoltage trip	R	○	○	○	○	○	○	○	○			
Shunt trip	F	○	○	○	○	○	○	○	○			
Earth alarm switch	L	○	○	○	○	○	○	○	○			
External accessories Page 07/60												
Handle padlocking device	Cap type Q1	○	○	○	○	○	○	○	○			
Handle padlocking device	Plate type Q2	○	○	○	○	○	○	○	○			
Operating handle	N-type N	○	○	○	○	○	○	○	○			
Operating handle	V-type V	○	○	○	○	○	○	○	○			
Terminal cover	Short BTCS	○	○	○	○	○	○	○	○			
Terminal cover	Long BTCL	○	○	○	○	○	○	○	○			
Insulation barrier	Interphase BP	○	○	○	○	○	○	○	○			
Handle locking cover	L1	○	○	○	○	○	○	○	○			
Flat terminal	SS	○	○	○	○	○	○	○	○			
Block terminal	SL	○	○	○	○	○	○	○	○			

●: Approved ○: Available —: Not available ▲: Factory-mounted accessory  
 Note: \*1 Electrical Appliance and Material Safety Law of Japan

Rated voltage (V)	Operational voltage range (V)
100–230–440	80–484

# Earth Leakage Circuit Breakers

## G-TWIN series

### Quick reference guide

#### ■ G-TWIN Standard Series

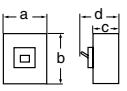
Ampere frame		250A								
Type		EW250EAG		EW250JAG		EW250SAG		EW250RAG		
Pole		3		3 4		3 4		3 4		
Rated current	Reference amb. temp. (40°C)	In(A)		175, 200, 225, 250		175,200,225		175,200,225,250		
Rated impulse withstand voltage		Uimp(kV)		6		6		6		
Isolation compliant		●		●		●		●		
Rated voltage Ue (AC V)		100-230-440								
Type of earth leakage trip action		AC type								
Instantaneous trip type	Rated sensitive current (mA)		30							
	Tripping time (s)		0.1 or less							
Instantaneous/time-delay trip type	Rated sensitive current (mA)		100/300/500/1000 changeover							
	Tripping time (s)		0.1/0.4/1/2 changeover							
	Inertia non-tripping time (s) (2IΔn)		0/0.2/0.5/1							
Rated breaking capacity Icu/Ics (kA)	IEC60947-2 EN60947-2 JISC8201-2-2	AC	440V	18/9	30/15	36/18	50/25			
			415V	18/9	30/15	36/18	50/25			
			400V	18/9	30/15	36/18	50/25			
			380V	18/9	30/15	36/18	50/25			
			230V	36/18	50/25	85/43	100/50			
			200V	36/18	50/25	85/43	100/50			
			100V	36/18	50/25	85/43	100/50			
	GB14048.2	AC	400V	18/9	30/15	36/18	50/25			
			230V	36/18	50/25	85/43	100/50			
Conforming to standards	CE Marking		● (TÜV)		● (TÜV)		● (TÜV)			
	CCC certificate		●		●		●			
Dimensions (mm)		a	105	105	140	105	140	105	140	
		b	165	165		165		165		
		c	68	68		68		68		
		d	95	95		95		95		
Mass (kg)		1.8	1.8	2.3	1.8	2.3	1.8	2.3		
Tripping device		Thermal-magnetic								
Front mounting, front connection	No-mark	○	○	○	○	○	○	○		
Front mounting, rear connection	X	○	○	○	○	○	○	○		
Flush mounting, front connection	E	○	○	○	○	○	○	○		
Plug-in mounting	P	○	—	○	○	—	○	—		
Internal accessories Page 07/58										
Alarm switch	K	○	○	○	○	○	○	○		
Auxiliary switch	W	○	○	○	○	○	○	○		
Undervoltage trip	R	○	○	○	○	○	○	○		
Shunt trip	F	○	○	○	○	○	○	○		
Earth alarm switch	L	○	○	○	○	○	○	○		
External accessories Page 07/60										
Handle padlocking device	Cap type Q1	○	○	○	○	○	○	○		
Handle padlocking device	Plate type Q2	○	○	○	○	○	○	○		
Operating handle	N-type N	○	○	○	○	○	○	○		
Operating handle	V-type V	○	○	○	○	○	○	○		
Terminal cover	Short BT□S	○	○	○	○	○	○	○		
Terminal cover	Long BT□L	○	○	○	○	○	○	○		
Insulation barrier	Interphase BP	○	○	○	○	○	○	○		
Handle locking cover	L1	○	○	○	○	○	○	○		
Flat terminal	SS	○	○	○	○	○	○	○		
Block terminal	SL	○	○	○	○	○	○	○		

●: Approved ○: Available —: Not available ▲: Factory-mounted accessory  
 Note: \*1 Electrical Appliance and Material Safety Law of Japan

Rated voltage (V)	Operational voltage range (V)
100-230-440	80-484

# Earth Leakage Circuit Breakers

## G-TWIN series

### Quick reference guide

#### ■ G-TWIN Standard Series

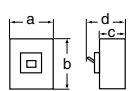
Ampere frame		400A										
Type		EW400EAG		EW400SAG		EW400RAG		EW400HAG				
Pole		3		3		3		4				
Rated current	Reference amb. temp. (40°C)	In(A)		250, 300, 350, 400								
Rated impulse withstand voltage		Uimp(kV)		6		6		6				
Isolation compliant		●		●		●		●				
Rated voltage Ue (AC V)		IEC		100-230-440								
Type of earth leakage trip action		AC type										
Instantaneous trip type	Rated sensitive current (mA)		30									
	Tripping time (s)		0.1 or less									
Instantaneous/time-delay trip type	Rated sensitive current (mA)		100/300/500/1000 changeover									
	Tripping time (s)		0.1/0.4/1/2 changeover									
	Inertia non-tripping time (s) (2IΔn)		0/0.2/0.5/1									
Rated breaking capacity Icu/Ics (kA)	IEC60947-2 EN60947-2 JISC8201-2-2	AC	440V	30/15	36/18	50/25	70/35					
			415V	30/15	36/18	50/25	70/35					
			400V	30/15	36/18	50/25	70/35					
			380V	30/15	36/18	50/25	70/35					
			230V	50/25	85/43	100/50	125/63					
			200V	50/25	85/43	100/50	125/63					
			100V	50/25	85/43	100/50	125/63					
	GB14048.2	AC	400V	30/15	36/18	50/25	70/35					
			230V	50/25	85/43	100/50	125/63					
			Conforming to standards		CE Marking		● (TÜV)		● (TÜV)		● (TÜV)	
CCC certificate		●		●		●		●				
Dimensions (mm)		a	140	140	140	185	140	185				
		b	257	257	257		257					
		c	103	103	103		103					
		d	146	146	146		146					
		Mass (kg)	5.8		5.8		5.8		7.8		5.8	
Tripping device		Thermal-magnetic										
Front mounting, front connection	No-mark	○	○	○	○	○	○	○	○			
Front mounting, rear connection	X	○	○	○	○	○	○	○	○			
Flush mounting, front connection	E	○	○	○	○	○	○	○	○			
Plug-in mounting	P	○	○	○	-	○	-	○	-			
Internal accessories		Page 07/59										
Alarm switch	K	○	○	○	○	○	○	○	○			
Auxiliary switch	W	○	○	○	○	○	○	○	○			
Undervoltage trip	R	○	○	○	○	○	○	○	○			
Shunt trip	F	○	○	○	○	○	○	○	○			
Earth alarm switch	L	▲	▲	▲	▲	▲	▲	▲	▲			
External accessories		Page 07/60										
Handle padlocking device	Cap type	QN	○	○	○	○	○	○	○			
Handle padlocking device	Plate type	Q2	○	○	○	○	○	○	○			
Operating handle	N-type	N	○	○	○	○	○	○	○			
Operating handle	V-type	V	○	○	○	○	○	○	○			
Terminal cover	Short	BT□S	○	○	○	○	○	○	○			
Terminal cover	Long	BT□L	○	○	○	○	○	○	○			
Insulation barrier	Interphase	BP	○	○	○	○	○	○	○			
Handle locking cover		L1	○	○	○	○	○	○	○			
Flat terminal		SS	○*2	○*2	○*2	○*2	○*2	○*2	○*2			
Block terminal		SL	○	○	○	○	○	○	○			

●: Approved ○: Available -: Not available ▲: Factory-mounted accessory  
 Note: \*1 Electrical Appliance and Material Safety Law of Japan  
 \*2 Standard provided

Rated voltage (V)	Operational voltage range (V)
100-230-440	80-484

# Earth Leakage Circuit Breakers

## G-TWIN series

### Quick reference guide

#### ■ G-TWIN Standard Series

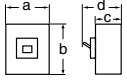
Ampere frame		630A			800A						
Type		EW630EAG	EW630RAG	EW630HAG	EW800EAG	EW800RAG	EW800HAG				
Pole		3	3	3	3	3	3				
Rated current	Reference amb. temp. (40°C)	In(A)			700, 800						
Rated impulse withstand voltage		Uimp(kV)		6	6	6	6				
Isolation compliant		●	●	●	●	●	●				
Rated voltage Ue (AC V)		100-230-440									
Type of earth leakage trip action		AC type									
Instantaneous/time-delay trip type	Rated sensitive current (mA)	100/300/500/1000 changeover									
	Tripping time (s)	0.1/0.4/1/2 changeover									
	Inertia non-tripping time (s) (2IΔn)	0/0.2/0.5/1									
Rated breaking capacity Icu/Ics (kA)	IEC60947-2 EN60947-2 JISC8201-2-2	AC	440V	36/18	50/25	70/35	36/18	50/25	70/35		
			415V	36/18	50/25	70/35	36/18	50/25	70/35		
			400V	36/18	50/25	70/35	36/18	50/25	70/35		
			380V	36/18	50/25	70/35	36/18	50/25	70/35		
			230V	50/25	100/50	125/63	50/25	100/50	125/63		
			200V	50/25	100/50	125/63	50/25	100/50	125/63		
	GB14048.2	AC	400V	36/18	50/25	70/35	36/18	50/25	70/35		
			230V	50/25	100/50	125/63	50/25	100/50	125/63		
					400V	36/18	50/25	70/35	36/18	50/25	70/35
					230V	50/25	100/50	125/63	50/25	100/50	125/63
Conforming to standards	CE Marking	● (TÜV)	● (TÜV)	● (TÜV)	● (TÜV)	● (TÜV)	● (TÜV)				
	CCC certificate	●	●	●	●	●	●				
Dimensions (mm)		a	210	210	210	210	210	210			
		b	275	275	275	275	275	275			
		c	103	103	103	103	103	103			
		d	146	146	146	146	146	146			
		Mass (kg)		9.1	9.1	9.1	9.6	9.6	9.6		
Tripping device		Thermal-magnetic									
Front mounting, front connection	No-mark	○	○	○	○	○	○				
Front mounting, rear connection	X	○	○	○	○	○	○				
Flush mounting, front connection	E	○	○	○	○	○	○				
Plug-in mounting	P	○	○	○	○	○	○				
Internal accessories		Page 07/59									
Alarm switch	K	○	○	○	○	○	○				
Auxiliary switch	W	○	○	○	○	○	○				
Undervoltage trip	R	○	○	○	○	○	○				
Shunt trip	F	○	○	○	○	○	○				
Earth alarm switch	L	▲	▲	▲	▲	▲	▲				
External accessories		Page 07/60									
Handle padlocking device	Cap type	QN	○	○	○	○	○				
Handle padlocking device	Plate type	Q2	○	○	○	○	○				
Operating handle	N-type	N	○	○	○	○	○				
Operating handle	V-type	V	○	○	○	○	○				
Terminal cover	Short	BT□S	○	○	○	○	○				
Terminal cover	Long	BT□L	○	○	○	○	○				
Insulation barrier	Interphase	BP	○	○	○	○	○				
Handle locking cover		L1	○	○	○	○	○				
Flat terminal		SS	○*2	○*2	○*2	○*2	○*2				
Block terminal		SL	○	○	○	○	○				

●: Approved ○: Available –: Not available ▲: Factory-mounted accessory

Note: \*1 Electrical Appliance and Material Safety Law of Japan

\*2 Standard provided

Rated voltage (V)	Operational voltage range (V)
100–230–440	80–484

# Earth Leakage Circuit Breakers

## G-TWIN series

### Quick reference guide

#### ■ G-TWIN Global Series

Ampere frame		50A		100A		
Type		EW50RAGU		EW100EAGU		
Pole		3		2      3		
Rated current	Reference amb. temp. (40°C)	In(A)	3, 5, 10, 15, 20, 30, 32, 40, 50			
Rated impulse withstand voltage	Uimp(kV)	6		4      6		
Isolation compliant		●		●      ●		
Rated voltage Ue (AC V)	IEC	100-230-440		100-230      100-230-440		
	UL	240		240      240		
Rated sensitive current (mA)		30, 50, 100/200/500 changeover		30, 100/200 changeover      30, 50, 100/200/500 changeover		
Tripping time (s)		0.1 or less		0.1 or less      0.1 or less		
Rated breaking capacity	IEC 60947-2 EN 60947-2 JIS C 8201-2-2 Icu/Ics (kA)	AC	440V	10/5	7.5/4	10/5
			415V	10/5	7.5/4	10/5
			400V	10/5	7.5/4	10/5
			380V	10/5	7.5/4	10/5
			230V	25/13	7.5/4	25/13
			200V	25/13	7.5/4	25/13
			100V	25/13	10/5	25/13
	GB14048.2 Icu/Ics(kA)	AC	400V	10/5	7.5/4	10/5
			230V	25/13	10/5	25/13
	UL489 CAN/CSA C22.2 NO.5 (kA)	AC	480V/Δ	–	–	–
			480V/Y	–	–	–
			240V	14	14	14
Conforming to standards	CE Marking		● (TÜV)		● (TÜV)      ● (TÜV)	
	CCC certificate		●		●      ●	
	UL Listed (NEMA AB1)		●		●      ●	
	Electrical Appliance and Material Safety Law *1		●		●      ●	
Dimensions (inch(mm))			a	2.953 (75)	2.953 (75)	2.953 (75)
			b	4.724 (120)	4.724 (120)	4.724 (120)
			c	2.362 (60)	2.362 (60)	2.362 (60)
			d	3.307 (84)	3.307 (84)	3.307 (84)
Mass (kg)		0.6		0.6      0.6		
Tripping device		Hydraulic-magnetic				
Connecting terminal		Page 07/26				
Screw	S□	○	○	○	○	
Flat		○	○	○	○	
Block		–	–	–	–	
Internal accessories		Page 07/57				
Alarm switch	K	○	○	○	○	
Auxiliary switch	W	○	○	○	○	
Undervoltage trip	R	○	○	○	○	
Shunt trip	F	○	○	○	○	
Earth alarm switch	L	–	–	–	–	
External accessories		Page 07/60				
Operating handle N-type	N	○	○	○	○	
Operating handle V-type	V	○	○	○	○	
Terminal cover Short	BT□S	○*2	○	○	○	
Terminal cover Long	BT□L	○	○	○	○	
Insulation barrier Interphase	BP	○	○	○	○	

●: Approved ○: Available –: Not available  
 Note: \*1 Electrical Appliance and Material Safety Law of Japan  
 \*2 Standard provided

Rated voltage (V)	Operational voltage range (V)
100–230	80–264
240	80–264
100–230–440	80–484

# Earth Leakage Circuit Breakers

## G-TWIN series

### Quick reference guide

#### ■ G-TWIN Global Series

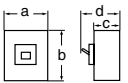
Ampere frame		125A	
Type		<b>EW125JAGU</b>	<b>EW125RAGU</b>
Pole		3	3
Rated current Reference amb. temp. (40°C)	In(A)	15, 20, 30, 40, 50, 60, 75, 100, 125	
Rated impulse withstand voltage	Uimp(kV)	6	6
Isolation compliant		●	●
Rated voltage Ue (AC V)	IEC	100-230-440	
	UL	240-480	
Type of earth leakage trip action		AC type	
Instantaneous trip type	Rated sensitive current (mA)	30	
	Tripping time (s)	0.1 or less	
Instantaneous/time-delay trip type	Rated sensitive current (mA)	100/200/500/1000 changeover	
	Tripping time (s)	0.1/0.4/1/2 changeover	
	Inertia non-tripping time (s) (2IΔn)	0/0.2/0.5/1	
Rated breaking capacity	IEC60947-2 EN60947-2 JISC8201-2-2 Icu/Ics (kA)	AC 440V	30/15 50/25
		415V	30/15 50/25
		400V	30/15 50/25
		380V	30/15 50/25
		230V	50/25 100/50
		200V	50/25 100/50
	GB14048.2 Icu/Ics (kA)	AC 400V	30/15 50/25
		230V	50/25 100/50
	UL489 CAN/CSA C22.2 NO.5 (kA)	AC 480V/Δ	30 50
		480V/Y	30 50
240V	50 100		
Conforming to standards	CE Marking	● (TÜV)	● (TÜV)
	CCC certificate	●	●
	UL Listed (NEMA AB1)	●	●
	Electrical Appliance and Material Safety Law *1	● (except for 125A)	● (except for 125A)
Dimensions (inch(mm))		a	3.543 (90)
		b	6.732 (171)
		c	2.677 (68)
		d	3.740 (95)
Mass (kg)		1.3	1.3
Tripping device		Thermal-magnetic	
Connecting terminal Page 07/26			
Screw	S□	○	○
Flat		○	○
Block		○	○
Internal accessories Page 07/58			
Alarm switch	K	○	○
Auxiliary switch	W	○	○
Undervoltage trip	R	○	○
Shunt trip	F	○	○
Earth alarm switch	L	○	○
External accessories Page 07/60			
Operating handle N-type	N	○	○
Operating handle V-type	V	○	○
Operating handle F-type	F	○	○
Terminal cover Short	BT□S	○ *2	○ *2
Terminal cover Long	BT□L	○	○
Insulation barrier Interphase	BP	○	○

●: Approved ○: Available -: Not available

Note: \*1 Electrical Appliance and Material Safety Law of Japan

\*2 Standard provided

Rated voltage (V)	Operational voltage range (V)
240-480	80-504
100-230-440	80-484

# Earth Leakage Circuit Breakers

## G-TWIN series

### Quick reference guide

#### ■ G-TWIN Global Series

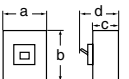
Ampere frame		250A	
Type		EW250JAGU	EW250RAGU
Pole		3	3
Rated current	Reference amb. temp. (40°C)	In(A)	125, 150, 160, 175, 200, 225, 250
Rated impulse withstand voltage		Uimp(kV)	6
Isolation compliant			●
Rated voltage Ue (AC V)		IEC	100-230-440
		UL	240-480
Type of earth leakage trip action		AC type	
Instantaneous trip type	Rated sensitive current (mA)		30
	Tripping time (s)		0.1 or less
Instantaneous/time-delay trip type	Rated sensitive current (mA)		100/200/500/1000 changeover
	Tripping time (s)		0.1/0.4/1/2 changeover
	Inertia non-tripping time (s) (2IΔn)		0/0.2/0.5/1
Rated breaking capacity	IEC60947-2 EN60947-2 JISC8201-2-2 Icu/Ics (kA)	AC	440V 30/15 50/25
			415V 30/15 50/25
			400V 30/15 50/25
			380V 30/15 50/25
			230V 50/25 100/50
			200V 50/25 100/50
	GB14048.2 Icu/Ics (kA)	AC	400V 30/15 50/25
			230V 50/25 100/50
	UL489 CAN/CSA C22.2 NO.5 (kA)	AC	480V/Δ 30 50
			480V/Y 30 50
		240V 50 100	
Conforming to standards	CE Marking		● (TÜV)
	CCC certificate		●
	UL Listed (NEMA AB1)		●
Dimensions (inch(mm))		a	4.134 (105)
		b	7.126 (181)
		c	2.677 (68)
		d	3.740 (95)
			3.740 (95)
Mass (kg)			1.8
Tripping device			Thermal-magnetic
Connecting terminal	Page 07/26		
Screw	S□	○	○
Flat		○	○
Block		○	○
Internal accessories	Page 07/58		
Alarm switch	K	○	○
Auxiliary switch	W	○	○
Undervoltage trip	R	○	○
Shunt trip	F	○	○
Earth alarm switch	L	○	○
External accessories	Page 07/60		
Operating handle N-type	N	○	○
Operating handle V-type	V	○	○
Operating handle F-type	F	○	○
Terminal cover Short	BT□S	○*1	○*1
Terminal cover Long	BT□L	○	○
Insulation barrier Interphase	BP	○	○

●: Approved ○: Available -: Not available  
Note: \*1 Standard provided

Rated voltage (V)	Operational voltage range (V)
240-480	80-504
100-230-440	80-484

# Earth Leakage Circuit Breakers

## G-TWIN series

### Quick reference guide

#### ■ G-TWIN Global Series

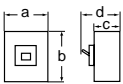
Ampere frame		400A				
Type		EW400SAGU	EW400RAGU	EW400HAGU		
Pole		3	3	3		
Rated current	Reference amb. temp. (40°C)	In(A)	250, 300, 350, 400			
Rated impulse withstand voltage		Uimp(kV)	6	6		
Isolation compliant			●	●		
Rated voltage Ue (AC V)		IEC	100-230-440			
		UL	240-480			
Type of earth leakage trip action		AC type				
Instantaneous trip type	Rated sensitive current (mA)		30			
	Tripping time (s)		0.1 or less			
Instantaneous/time-delay trip type	Rated sensitive current (mA)		100/200/500/1000 changeover			
	Tripping time (s)		0.1/0.4/1/2 changeover			
	Inertia non-tripping time (s) (2IΔn)		0/0.2/0.5/1			
Rated breaking capacity	IEC60947-2 EN60947-2 JISC8201-2-2 Icu/Ics (kA)	AC	440V	36/18	50/25	70/35
			415V	36/18	50/25	70/35
			400V	36/18	50/25	70/35
			380V	36/18	50/25	70/35
			230V	85/43	100/50	125/63
			200V	85/43	100/50	125/63
	GB14048.2 Icu/Ics (kA)	AC	400V	36/18	50/25	70/35
			230V	85/43	100/50	125/63
	UL489 CAN/CSA C22.2 NO.5 (kA)	AC	480V/Δ	35	50	65 (with block terminal: 50)
			480V/Y	35	50	65 (with block terminal: 50)
			240V	50	100	100
	Conforming to standards	CE Marking		● (TÜV)	● (TÜV)	● (TÜV)
CCC certificate		●	●	●		
UL Listed (NEMA AB1)		●	●	●		
Dimensions (inch(mm))		a	5.512 (140)	5.512 (140)	5.512 (140)	
		b	10.12 (257)	10.12 (257)	10.12 (257)	
		c	4.055 (103)	4.055 (103)	4.055 (103)	
		d	5.748 (146)	5.748 (146)	5.748 (146)	
Mass (kg)			6.3	6.3	6.3	
Tripping device		Thermal-magnetic				
Connecting terminal		Page 07/26				
Screw	□	–	–	–		
Flat	○	○	○	○		
Block	○	○	○	○		
Internal accessories		Page 07/58				
Alarm switch	K	○	○	○		
Auxiliary switch	W	○	○	○		
Undervoltage trip	R	○	○	○		
Shunt trip	F	○	○	○		
Earth alarm switch	L	▲	▲	▲		
External accessories		Page 07/60				
Operating handle N-type	N	○	○	○		
Operating handle V-type	V	○	○	○		
Operating handle F-type	F	○	○	○		
Terminal cover Short	BT□S	○	○	○		
Terminal cover Long	BT□L	○	○	○		
Insulation barrier Interphase	BP	○	○	○		

●: Approved ○: Available –: Not available ▲: Factory-mounted accessory

Rated voltage (V)	Operational voltage range (V)
240–480	80–504
100–230–440	80–484



# Earth Leakage Circuit Breakers

## G-TWIN series

### Quick reference guide

#### ■ G-TWIN Global Series

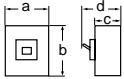
Ampere frame		630A		
Type		EW630RAGU		
Pole		3		
Rated current	Reference amb. temp. (40°C)	In(A)	500, 600, 630*1	
Rated impulse withstand voltage		Uimp(kV)	6	
Isolation compliant		●		
Rated voltage Ue (AC V)		IEC	100-230-440	
		UL	240-480	
Instantaneous/time-delay trip type	Rated sensitive current (mA)		100/200/500/1000 changeover	
	Tripping time (s)		0.1/0.4/1/2 changeover	
	Inertia non-tripping time (s) (2IΔn)		0/0.2/0.5/1	
Rated breaking capacity	IEC60947-2 EN60947-2 JISC8201-2-2 Icu/Ics (kA)	AC	440V	50/25
			415V	50/25
			400V	50/25
			380V	50/25
			230V	100/50
			200V	100/50
	GB14048.2 Icu/Ics (kA)	AC	400V	50/25
			230V	100/50
	UL489 CAN/CSA C22.2 NO.5 (kA)	AC	480V/Δ	50
			480V/Y	50
		240V	100	
Conforming to standards	CE Marking		● (TÜV)	
	CCC certificate		●	
	UL Listed (NEMA AB1)		●	
Dimensions (inch(mm))		a	8.268 (210)	
		b	10.83 (275)	
		c	4.055 (103)	
		d	5.748 (146)	
		Mass (kg)		
Tripping device		Thermal-magnetic		
Connecting terminal		Page 07/27		
Screw	S□	-		
Flat	○			
Block	○			
Internal accessories		Page 07/59		
Alarm switch	K	○*2		
Auxiliary switch	W	○*2		
Undervoltage trip	R	○*2		
Shunt trip	F	○*2		
Earth alarm switch	L	▲		
External accessories		Page 07/60		
Operating handle N-type	N	○		
Operating handle V-type	V	○		
Terminal cover Short	BT□S	○		
Terminal cover Long	BT□L	○		
Insulation barrier Interphase	BP	○		

●: Approved ○: Available -: Not available ▲: Factory-mounted accessory  
 Note: \*1 Breakers for 630A cannot be manufactured with block terminals.  
 \*2 Block terminals are not available.

Rated voltage (V)	Operational voltage range (V)
240-480	80-504
100-230-440	80-484

# Earth Leakage Circuit Breakers

## G-TWIN series

### Quick reference guide

#### ■ G-TWIN Standard Series / Motor protection

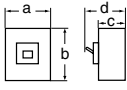
Ampere frame		32A			
Type		EW32EAM		EW32SAM	
Pole		3		3	
Rated current Reference amb. temp. (40°C)	In(A)	1.4, 2.6, 4, 5, 8, 10, 16, 24, 32		0.7, 1.4, 2, 2.6, 4, 5, 8, 10, 12, 16, 24, 32	
Rated impulse withstand voltage	Uimp(kV)	4		4	
Isolation compliant		●		●	
Rated voltage Ue(AC V)		100-230-440		100-230-440	
Rated sensitive current (mA)		30, 100		30, 100/200/500 changeover	
Tripping time (s)		0.1 or less		0.1 or less	
Rated breaking capacity Icu/Ics (kA)	IEC 60947-2 EN 60947-2 JIS C 8201-2-2	AC	440V	1.5/1	2.5/2
			415V	1.5/1	2.5/2
			400V	1.5/1	2.5/2
			380V	1.5/1	2.5/2
			230V	2.5/2	5/3
			200V	2.5/2	5/3
			100V	5/3	5/3
	GB14048.2	AC	400V	1.5/1	2.5/2
		230V	2.5/2	5/3	
Conforming to standards	CE Marking		●	●	
	CCC certificate		●	●	
	Electrical Appliance and Material Safety Law <sup>*1</sup>		●	●	
Dimensions (mm)		a	75	75	
		b	100	100	
		c	60	60	
		d	84	84	
		Mass (kg)	0.5		0.5
Tripping device		Hydraulic-magnetic		Hydraulic-magnetic	
Front mounting, front connection	No-mark	○	○		
Front mounting, rear connection	X	○	○		
Flush mounting, front connection	E	○	○		
Flush mounting, top & bottom connection	Y	○	○		
Plug-in mounting	P	○	○		
IEC 35mm wide rail mounting	No-mark	○	○		
Internal accessories Page 07/57					
Alarm switch	K	○	○		
Auxiliary switch	W	○	○		
Undervoltage trip	R	○	○		
Shunt trip	F	○	○		
Earth alarm switch	L	-	-		
External accessories Page 07/60					
Handle padlocking device Cap type	QN	○	○		
Handle padlocking device Plate type	Q2	▲	▲		
Operating handle N-type	N	○	○		
Operating handle V-type	V	○	○		
Terminal cover Short	BTCS	○	○		
Terminal cover Long	BTCL	○	○		
Insulation barrier Interphase	BP	○	○		
Insulation barrier Earth	BL	○	○		
Handle locking cover	L1	○	○		
Flat terminal	SS	○	○		
Block terminal	SL	-	-		

●: Approved ○: Available -: Not available ▲: Factory-mounted accessory

Note: <sup>\*1</sup> Electrical Appliance and Material Safety Law of Japan

Rated voltage (V)	Operational voltage range (V)
100-230-440	80-484

# Earth Leakage Circuit Breakers

## G-TWIN series

### Quick reference guide

#### ■ G-TWIN Standard Series / Motor protection

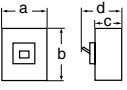
Ampere frame		50A		
Type		<b>EW50EAM</b>	<b>EW50SAM</b>	
Pole		3	3	
Rated current Reference amb. temp. (40°C)	In(A)	45	0.7, 1.4, 2, 2.6, 4, 5, 8, 10, 12, 16, 24, 32, 40, 45	
Rated impulse withstand voltage	Uimp(kV)	4	6	
Isolation compliant		●	●	
Rated voltage Ue (AC V)		100-230-440	100-230-440	
Rated sensitive current (mA)		30, 100/200 changeover	30, 100/200/500 changeover	
Tripping time (s)		0.1 or less	0.1 or less	
Rated breaking capacity Icu/Ics (kA)	IEC 60947-2 EN 60947-2 JIS C 8201-2-2	AC	440V 2.5/2	7.5/4
			415V 2.5/2	7.5/4
			400V 2.5/2	7.5/4
			380V 2.5/2	7.5/4
			230V 5/3	10/5
			200V 5/3	10/5
			100V 5/3	10/5
	GB14048.2	AC	400V 2.5/2	7.5/4
		230V 5/3	10/5	
Conforming to standards	CE Marking		●	●
	CCC certificate		●	●
	Electrical Appliance and Material Safety Law <sup>*1</sup>		●	●
Dimensions (mm)		a	75	75
		b	100	100
		c	60	60
		d	84	84
Mass (kg)		0.6		
Tripping device		Hydraulic-magnetic		
Front mounting, front connection	No-mark	○	○	
Front mounting, rear connection	X	○	○	
Flush mounting, front connection	E	○	○	
Flush mounting, top & bottom connection	Y	○	○	
Plug-in mounting	P	○	○	
IEC 35mm wide rail mounting	No-mark	○	○	
Internal accessories Page 07/57				
Alarm switch	K	○	○	
Auxiliary switch	W	○	○	
Undervoltage trip	R	○	○	
Shunt trip	F	○	○	
Earth alarm switch	L	-	-	
External accessories Page 07/60				
Handle padlocking device Cap type	QN	○	○	
Handle padlocking device Plate type	Q2	▲	▲	
Operating handle N-type	N	○	○	
Operating handle V-type	V	○	○	
Terminal cover Short	BTCS	○	○	
Terminal cover Long	BTCL	○	○	
Insulation barrier Interphase	BP	○	○	
Insulation barrier Earth	BL	○	○	
Handle locking cover	L1	○	○	
Flat terminal	SS	○	○	
Block terminal	SL	-	-	

●: Approved ○: Available -: Not available ▲: Factory-mounted accessory  
 Note: <sup>\*1</sup> Electrical Appliance and Material Safety Law of Japan

Rated voltage (V)	Operational voltage range (V)
100-230-440	80-484

# Earth Leakage Circuit Breakers

## G-TWIN series

### Quick reference guide

#### ■ G-TWIN Standard Series / Motor protection

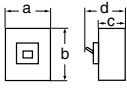
Ampere frame		63A		100A		
Type		<b>EW63EAM</b>		<b>EW63SAM</b>		
Pole		3		3		
Rated current	Reference amb. temp. (40°C)	In(A)	63	63	63, 75, 90	
Rated impulse withstand voltage		Uimp(kV)	6	6	6	
Isolation compliant		●		●		
Rated voltage Ue (AC V)		100-230-440		100-230-440		
Rated sensitive current (mA)		30, 100/200 changeover		30, 100/200/500 changeover		
Tripping time (s)		0.1 or less		0.1 or less		
Rated breaking capacity Icu/Ics (kA)	IEC 60947-2 EN 60947-2 JIS C 8201-2-2	AC	440V	2.5/2	7.5/4	10/5
			415V	2.5/2	7.5/4	10/5
		AC	400V	2.5/2	7.5/4	10/5
			380V	2.5/2	7.5/4	10/5
			230V	5/3	10/5	25/13
		AC	200V	5/3	10/5	25/13
			100V	5/3	10/5	25/13
	GB14048.2	AC	400V	2.5/2	7.5/4	10/5
			230V	5/3	10/5	25/13
	Conforming to standards	CE Marking		●	●	●
CCC certificate		●	●	●		
Electrical Appliance and Material Safety Law*1		●	●	●		
Dimensions (mm)		a	75	75	75	
		b	100	100	100	
		c	60	60	60	
		d	84	84	84	
		Mass (kg)	0.6		0.6	
Tripping device		Hydraulic-magnetic		Hydraulic-magnetic		
Front mounting, front connection	No-mark	○	○	○	○	
Front mounting, rear connection	X	○	○	○	○	
Flush mounting, front connection	E	○	○	○	○	
Flush mounting, top & bottom connection	Y	○	○	○	○	
Plug-in mounting	P	○	○	○	○	
IEC 35mm wide rail mounting	No-mark	○	○	○	○	
Internal accessories		Page 07/57				
Alarm switch	K	○	○	○	○	
Auxiliary switch	W	○	○	○	○	
Undervoltage trip	R	○	○	○	○	
Shunt trip	F	○	○	○	○	
Earth alarm switch	L	-	-	-	-	
External accessories		Page 07/60				
Handle padlocking device	Cap type	QN	○	○	○	
Handle padlocking device	Plate type	Q2	▲	▲	▲	
Operating handle	N-type	N	○	○	○	
Operating handle	V-type	V	○	○	○	
Terminal cover	Short	BTCS	○	○	○	
Terminal cover	Long	BTCL	○	○	○	
Insulation barrier	Interphase	BP	○	○	○	
Insulation barrier	Earth	BL	○	○	○	
Handle locking cover		L1	○	○	○	
Flat terminal		SS	○	○	○	
Block terminal		SL	-	-	-	

●: Approved ○: Available -: Not available ▲: Factory-mounted accessory

Note: \*1 Electrical Appliance and Material Safety Law of Japan

Rated voltage (V)	Operational voltage range (V)
100-230-440	80-484

# Earth Leakage Circuit Breakers

## G-TWIN series

### Quick reference guide

#### ■ G-TWIN Standard Series / Motor protection

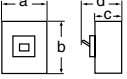
Ampere frame		125A		250A				
Type		EW125JAM	EW125RAM	EW250EAM	EW250JAM	EW250RAM		
Pole		3	3	3	3	3		
Rated current	Reference amb. temp. (40°C)	16, 24, 32, 40, 45, 60, 75, 90			125, 150, 175, 225			
Rated impulse withstand voltage	Uimp(kV)	6	6	6	6	6		
Isolation compliant		●	●	●	●	●		
Rated voltage Ue (AC V)		100-230-440	100-230-440	100-230-440	100-230-440	100-230-440		
Type of earth leakage trip action		AC type			AC type			
Instantaneous trip type	Rated sensitive current (mA)	30			30			
	Tripping time (s)	0.1 or less			0.1 or less			
Instantaneous/ time-delay trip type	Rated sensitive current (mA)	100/200/500/1000 changeover			100/200/500/1000 changeover			
	Tripping time (s)	0.1/0.4/1/2 changeover			0.1/0.4/1/2 changeover			
	Inertia non-tripping time (s) (2IΔn)	0/0.2/0.5/1			0/0.2/0.5/1			
Rated breaking capacity Icu/lcs (kA)	IEC 60947-2 EN 60947-2 JIS C 8201-2-2	AC	440V	30/15	50/25	18/9	30/15	50/25
			415V	30/15	50/25	18/9	30/15	50/25
			400V	30/15	50/25	18/9	30/15	50/25
			380V	30/15	50/25	18/9	30/15	50/25
			230V	50/25	100/50	36/18	50/25	100/50
			200V	50/25	100/50	36/18	50/25	100/50
	GB14048.2	AC	400V	30/15	50/25	18/9	30/15	50/25
			230V	50/25	100/50	36/18	50/25	100/50
			400V	30/15	50/25	18/9	30/15	50/25
			230V	50/25	100/50	36/18	50/25	100/50
Conforming to standards	CE Marking	●	●	●	●	●		
	CCC certificate	●	●	●	●	●		
	Electrical Appliance and Material Safety Law <sup>*1</sup>	●	●	—	—	—		
Dimensions (mm)		a	90	90	105	105	105	
		b	155	155	165	165	165	
		c	68	68	68	68	68	
		d	95	95	95	95	95	
		Mass (kg)		1.3	1.3	1.8	1.8	1.8
Tripping device		Thermal-magnetic	Thermal-magnetic	Thermal-magnetic	Thermal-magnetic	Thermal-magnetic		
Front mounting, front connection	No-mark	○	○	○	○	○		
Front mounting, rear connection	X	○	○	○	○	○		
Flush mounting, front connection	E	○	○	○	○	○		
Flush mounting, top & bottom connection	Y	○	○	○	○	○		
Plug-in mounting	P	○	○	○	○	○		
Internal accessories	Page 07/58							
Alarm switch	K	○	○	○	○	○		
Auxiliary switch	W	○	○	○	○	○		
Undervoltage trip	R	○	○	○	○	○		
Shunt trip	F	○	○	○	○	○		
Earth alarm switch	L	○	○	○	○	○		
External accessories	Page 07/60							
Handle padlocking device Cap type	Q1	○	○	○	○	○		
Handle padlocking device Plate type	Q2	○	○	○	○	○		
Operating handle N-type	N	○	○	○	○	○		
Operating handle V-type	V	○	○	○	○	○		
Terminal cover Short	BTCS	○	○	○	○	○		
Terminal cover Long	BTCL	○	○	○	○	○		
Insulation barrier Interphase	BP	○	○	○	○	○		
Insulation barrier Earth	BL	○	○	○	○	○		
Handle locking cover	L1	○	○	○	○	○		
Flat terminal	SS	○	○	○	○	○		
Block terminal	SL	—	—	—	—	—		

●: Approved ○: Available —: Not available

Note: <sup>\*1</sup> Electrical Appliance and Material Safety Law of Japan

Rated voltage (V)	Operational voltage range (V)
100-230-440	80-484

# Earth Leakage Circuit Breakers

## G-TWIN series

### Mounting modifications

#### ■ Mounting modifications

##### • Standard series

Standard type FUJI breakers are front mounting with front connections. The standard breaker can easily be modified to become front mounting rear connection type, flush mounting type and plug-in type. The additional parts such as insulation bases, barriers, covers and similar parts are added as required.

**Front mounting  
Front connection**



**BASIC DESIGN**

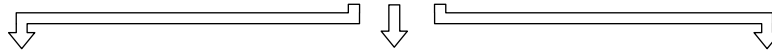

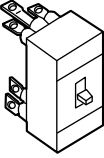
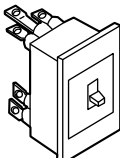
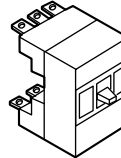
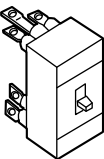
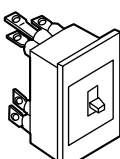
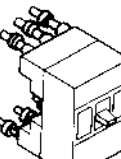
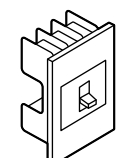
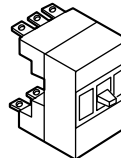
<p>Additional main parts</p> <p>Front mounting Rear connection (X type)</p>	<p>Additional main parts</p> <p>Flush mounting Rear connection (E type)</p>	<p>Additional main parts</p> <p>Plug-in mounting (P type)</p>
<p>Bar stud terminal</p> 	<p>Bar stud terminal</p> 	<p>Bar stud terminal</p> 
<p>EW32 EW50 EW63 EW100</p>	<p>EW32 EW50 EW63 EW100</p>	<p>EW32 EW50 EW63 EW100</p>
<p>Bar stud terminal</p> 	<p>Bar stud terminal</p> 	<p>Round stud terminal</p> 
<p>EW125 EW160 EW250 EW400 EW630 EW800</p> <p>Each stud can be turned by 90°</p>	<p>EW125 EW160 EW250 EW400 EW630 EW800</p> <p>Each stud can be turned by 90°</p>	<p>EW125</p>
<p>Additional main parts</p> <p>Flush mounting Top and bottom connection (Y type)</p>	<p>Decorative flush plate</p> 	<p>Bar stud terminal</p> 
<p>EW32 EW50 EW63 EW100</p>	<p>EW160 EW250 EW400 EW630 EW800</p> <p>Each stud can be turned by 90°</p>	<p>EW160 EW250 EW400 EW630 EW800</p>

• Global series

Front mounting  
Front connection



BASIC DESIGN

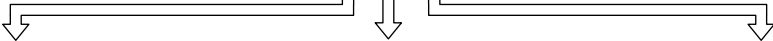

Screw

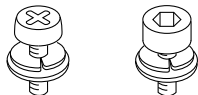

Flat terminal

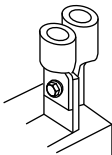

Block terminal

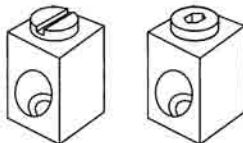

# Earth Leakage Circuit Breakers

## G-TWIN series

### Terminal connection

#### Terminal connection/Front mounting, front connection

##### • 32AF to 100AF

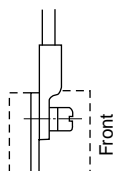
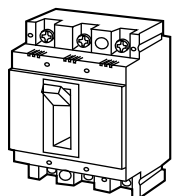

Flat terminal

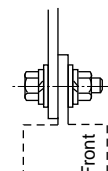
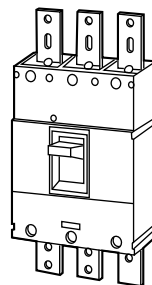

##### • 400AF to 800AF

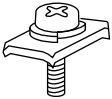

Flat terminal

Self lifting screw	Breaker type	Tightening torque (N•m)	Size
	EW32 EW50 EW100*	2.3 to 2.8	M5 × 14
	EW63 EW100	5.5 to 7.5	M8 × 15

\* Breaker of rated current : 50A

Hexagonal head bolt	Breaker type	Tightening torque (N•m)	Size (mm)
 	EW400	40 to 50	M12 × 35
	EW630 EW800	40 to 50	M12 × 40

##### • 125AF to 250AF

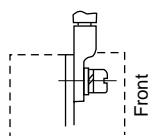

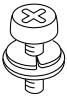
Pan-head screw	Breaker type	Tightening torque (N•m)	Size (mm)
	EW125	5.5 to 7.5	M8 × 16
	EW160 EW250	8.0 to 13.0	M8 × 16

#### Type of connection/up to 250AF

##### Front mounting front connection

##### Direct connection

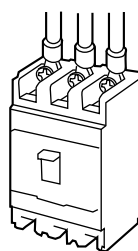
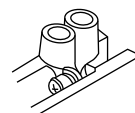

##### Flat terminal connection

Flat terminals are required.

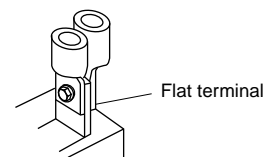

#### Flat bar studs/1-hole type

Breaker type	Pole	Type of flat terminal
EW32 EW50	2 3	<b>BZ6S10C502</b> <b>BZ6S10C503</b>
EW63 EW100*	2 3	<b>BZ6S10C1002</b> <b>BZ6S10C1003</b>
EW125	3 4	<b>BW9SS0CA-3</b> <b>BW9SS0CA-4</b>
EW160 EW250	3 4	<b>BW9SS0GA-3</b> <b>BW9SS0GA-4</b>

\* EW100 breaker of rated current 50A: BZ6S10C502 or 503.



# Earth Leakage Circuit Breakers

## G-TWIN series

### Wire size and terminal

#### ■ Wire size and crimp terminal











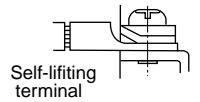
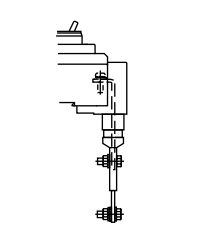
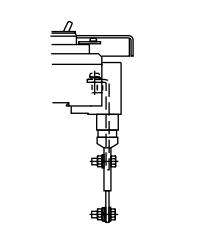
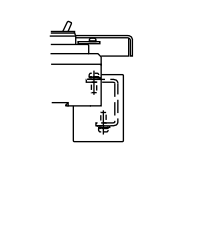
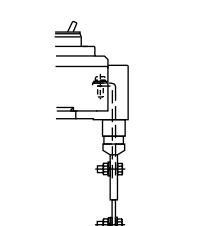
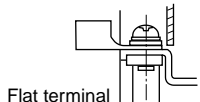
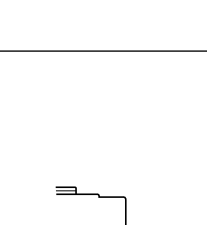
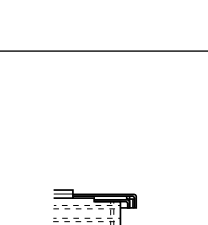

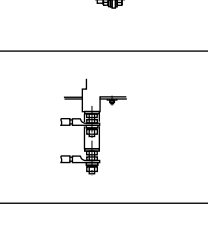
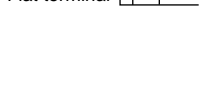
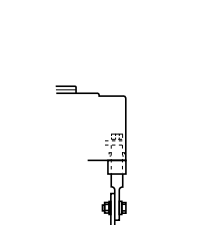
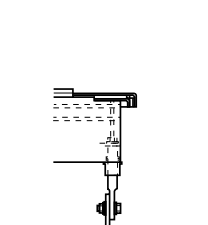
The following is the size recommendations for crimp terminals.

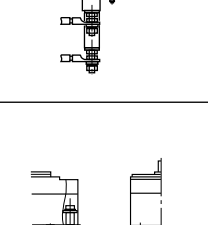
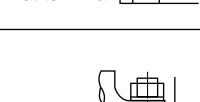
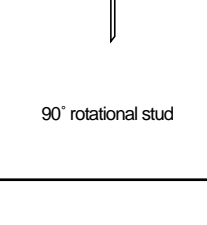
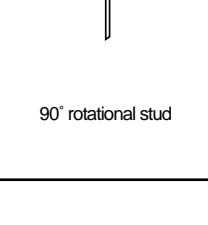
Crimp terminal R : JIS C2805  
 CB : JEM-1399  
 JST : Product of Japan Crimp Terminal Co., Ltd.

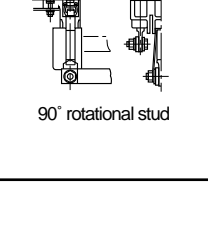
Ampere frame	Breaker	Wire size(mm <sup>2</sup> )										
		1.04   2.63	2.63   6.64	6.64   10.52	10.52   16.78	16.78   26.66	26.66   42.42	42.42   60.57	96.3   117.2	117.2   152.05	192.6   242.27	242.27   325
32	EW32	R2-5	R5.5-5	R8-5	R14-5							
50	EW50	R2-5	R5.5-5	R8-5	R14-5							
63	EW63	R2-8	R5.5-8	R8-8	R14-8	JST22-S8						
100	EW100	R2-8	R5.5-8	R8-8	R14-8	JST22-S8	JST38-S8					
125	EW125	R2-8	R5.5-8	R8-8	R14-8	R22-8	JST38-S8	CB60-8				
160 250	EW160 EW250					R22-8	R38-8	R60-8	CB100-8			
400	EW400						R38-12	R60-12	R100-12	R150-12	R200-12	JST325-12
630	EW630								R100-12	R150-12	R200-12	JST325-12
800	EW800								R100-12	R150-12	R200-12	JST325-12

#### ■ Breaker termination

##### • Standard

ELCB type	Front connection	Rear connection X	Flush mounting E	Y	Plug-in mounting P
EW32 EW50	 Self-lifting terminal				
EW63 EW100					
EW125	 Flat terminal				
EW160 EW250	 Flat terminal				
EW400 EW630 EW800	 Flat terminal	 90° rotational stud	 90° rotational stud		 90° rotational stud

07

# Earth Leakage Circuit Breakers

## G-TWIN series

### Wire size and terminal

#### ■ Notes on wiring (global series)

##### Notes on connecting wires (conductors)

- Connect wires to the UL breaker according to NEC (National Electric Code) or CEC (Canadian Electrical Code) Part 1.
- Use 75°C copper wires for wiring. UL-certified or CSA-certified wires are recommended.
- If a large current (for example, a short-circuit current) flows, it causes a huge electromagnetic force between wires. Therefore, be sure to secure the wires sufficiently.
- Re-tighten terminal screws periodically.

#### Block terminal connection

- Choose from the stranded wires shown in Table.

Wire size: AWG or MCM [mm <sup>2</sup> ]	No. of wires stranded
14 to 2 [2.1 to 33.6]	7
1 to 4/0 [42.4 to 107.2]	19
250 to 500 [127 to 250]	37

Values in [ ] are those converted from AWG or MCM sizes to mm<sup>2</sup>.

- \* See the instruction manual that comes with the breaker for more details.

Code	Terminal position		Applicable breaker type		
	Line	Load	EW50, 100	EW125, 250	EW400, 630, 800
Blank	Screw	Screw	●	●	—
Blank	Flat terminal	Flat terminal	—	—	●
SB	Block terminal	Block terminal	—	●	●
SF	Flat terminal	Flat terminal	●	●	—
S3	Screw	Flat terminal	●	●	—
S4	Flat terminal	Screw	●	●	—
S5	Screw	Block terminal	—	●	—
S6	Block terminal	Screw	—	●	—
S7	Flat terminal	Block terminal	—	●	●
S8	Block terminal	Flat terminal	—	●	●

#### Precautions

- Two wires of different sizes cannot be connected to the same block terminal.
- Be sure to use stranded wires according to Table "Number of wires stranded."
- Multi-conductor wires cannot be connected.
- Do not solder wires together.

#### Wire size and crimp terminal

##### • Crimp terminal connection

ELCB	Rated current (A)	Applicable crimp terminal			Connectable wire size (AWG)	Tightening torque (N•m)	Type of screw head and size (mm)
		J.S.T Mfg. Co., Ltd.	Nichifu Co., Ltd.	Daido Solderless Terminal Mfg. Co., Ltd.			
EW50RAGU	3	R2-5	R2-5M	2-S5, 2-5	14AWG	2.3-2.8	Cross/straight slotted pan-head screw M5 x 14
	5		R2-5				
	10						
	15						
	20	R5.5-5	R3.5-5S, R3.5-5L, 5.5-6N, R5.5-5S, R5.5-5	3.5-5, 5.5-S5, 5.5-5, 5.5-L5	12AWG		
30				10AWG			
40	R8-5	R8-5S, R8-5	8-S5, 8-5	8AWG			
50							
EW100EAGU	60	R14-8	R14-8S, R14-8	R14-S8, R14-8	6AWG	5.5-7.5	Cross/straight slotted pan-head screw M8 x 15
	75	22-S8	R22-8S, R22-8	R22-S8, 22-8	4AWG		
	100	38-S8	R38-8S	38-S8	3AWG		
EW125JAGU EW125RAGU	15	R2-8	R2-8	2-8, 2-B8	14AWG	5.8 (5.3-6.4)	Cross/straight slotted pan-head screw M8 x 16
	20	5.5-S8, R5.5-8	R3.5-8, R5.5-8	3.5-8, 5.5-8	12AWG		
	30		R5.5-8	5.5-8	10AWG		
	40	8-8NS, R8-8	R8-8	8-8	8AWG		
	50						
	60	14-8NS, 14-S8, R14-8	R14-8S, R14-8	14-S8, 14-8	6AWG		
	70	22-S8, R22-8, CB22-S8	R22-8S, R22-8, CB22-8S	22-S8, 22-8, CB22-8	4AWG		
	75						
	80						
	90	38-S8	R38-8S	38-S8	3AWG		
100				1AWG			
125							
EW250JAGU EW250RAGU	125	38-S8, R38-8	R38-8S, R38-8	38-S8, 38-8	1AWG	10.5 (8-13)	Hexagon socket head bolt M8 x 16
	150	60-S8, R60-8	R60-8, CB60-8, CB60-8S	60-8, CB60-8	1/0AWG		
	175	70-8	R70-8	70-8	2/0AWG		
	200	CB80-S8		CB80-8	3/0AWG		
	225	CB100-S8		CB100-8	4/0AWG		
250	CB150-S8	CB150-8	CB150-8	250MCM			

- Notes:
- AWG/MCM is the UL approved wire unit.
  - The allowable temperature of wire is 75°C. (UL CSA approved)
  - Be sure to use UL-certified or CSA-certified crimp tools commercially available.

# Earth Leakage Circuit Breakers

## G-TWIN series

### Wire size and terminal

• Flat terminal connection

ELCB	Rated current (A)	Applicable crimp terminal 75°C wire			Connectable wire size (AWG)	Tightening torque (N•m)		Type of screw head and size (mm)
		J.S.T Mfg. Co., Ltd.	Nichifu Co., Ltd.	Daido Solderless Terminal Mfg. Co., Ltd.		75°C wire	Wire side	
EW50RAGU	3	R2-5	R2-5M R2-5	2-S5, 2-5	14AWG	3.5 to 4.5	2.3 to 2.8	Hexagon socket head bolt M5 x 16
	5							
	10							
	15							
	20	R5.5-5	R3.5-5S, R3.5-5L, 5.5-6N. R5.5-5S, R5.5-5	3.5-5, 5.5-S5 5.5-5, 5.5-L5	12AWG			
	30				10AWG			
40	R8-5	R8-5S, R8-5	8-S5, 8-5	8AWG				
50								
EW100EAGU	60	R14-8	R14-8S, R14-8	R14-S8, R14-8	6AWG	8 to 10	5.5 to 7.5	Hexagon socket head bolt M8 x 22
	75	22-S8	R22-8S, R22-8	R22-S8, 22-8	4AWG			
	100	38-S8	R38-8S	38-S8	3AWG			
EW125JAGU	15	R2-8	R2-8	2-8, 2-B8	14AWG	9 (8 to 10)	5.8 (5.3 to 6.4)	Cross/straight slotted pan-head screw M8 x 16
EW125RAGU	20	5.5-S8, R5.5-8	R3.5-8, R5.5-8	3.5-8, 5.5-8	12AWG			
	30				R5.5-8			
	40	8-8NS, R8-8	R8-8	8-8	8AWG			
	50							
	60	14-8NS, 14-S8, R14-8	R14-8S, R14-8	14-S8, 14-8	6AWG			
	75	22-S8, R22-8, CB22-S8	R22-8S, R22-8, CB22-8S	22-S8, 22-8, CB22-8	4AWG			
	100	38-S8	R38-8S	38-S8	3AWG			
125				1AWG				
EW250JAGU	125	38-S8, R38-8	R38-8S, R38-8	38-S8, 38-8	1AWG	9 (8 to 10)	10.5 (8 to 13)	Hexagon socket head bolt M8 x 16
EW250RAGU	150	60-S8, R60-8	R60-8, CB60-8, CB60-8S	60-8, CB60-8	1/0AWG			
	175	70-8	R70-8	70-8	2/0AWG			
	200	CB80-S8		CB80-8	3/0AWG			
	225	CB100-S8		CB100-8	4/0AWG			
	250	CB150-S8	CB150-8	CB150-8	250MCM			
EW400SAGU	250	150-12	R150-12		250MCM	45 (40 to 50)	43.5 (39.2 to 48)	Hexagon head bolt M12 x 35
EW400RAGU	300	180-12	R180-12		350MCM			
EW400HAGU	350	325-12	R325-12N		500MCM			
	400	325-12 R80-12	R325-12N R80-12		500MCM 3/0AWG(x2)			
EW630RAGU	500	R150-12		R150-12	250MCM(x2)	47.04 (42.4 to 51.7)	47.04 (42.4 to 51.7)	Hexagon head bolt M12 x 40
	600	180-12		R180-12	350MCM(x2)			
	630	325-12	R325-12N	R325-12 □	500MCM(x2)			

Notes: • AWG/MCM is the UL approved wire unit.  
 • The allowable temperature of wire is 75°C. (UL CSA approved)

07

# Earth Leakage Circuit Breakers

## G-TWIN series

### Wire size and terminal

#### • Block terminal connection

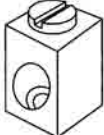
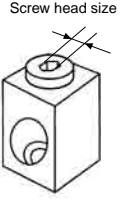
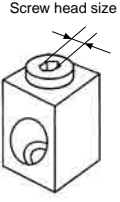
ELCB	Rated current (A)	Connectable wire size (AWG)	Tightening torque (N·m)	Type of screw head and size (mm)	Figure
EW125JAGU EW125RAGU	15 20 30 40 50 60 75 100 125	14AWG 12AWG 10AWG 8AWG 6AWG 4AWG 3AWG 1AWG	5.8 (5.8 to 6.4)	Slotted set screw	
EW250JAGU EW250RAGU	125 150 175 200 225 250	1AWG 1/0AWG 2/0AWG 3/0AWG 4/0AWG 250MCM	23 (23 to 25.3)	Hexagon socket head setscrew: 8 mm (5/16 inch)	
EW400SAGU EW400RAGU EW400HAGU	250 300 350 400	250MCM 350MCM 500MCM 3/0AWG(x2)	43.5 (43.5 to 48)	Hexagon socket head setscrew: 9.53 mm (3/8 inch)	
EW630RAGU	500 600	250MCM(x2) 350MCM(x2)	31.9 (31.9 to 35.1) 31.1 (31.1 to 34.2)	Hexagon socket head setscrew: 8 mm (5/16 inch) Hexagon socket head setscrew: 8 mm (5/16 inch)	

Notes: • AWG/MCM is the UL approved wire unit.  
• The allowable temperature of wire is 75°C. (UL CSA approved)

# Earth Leakage Circuit Breakers G-TWIN series Type number/Line protection

## ■ Type number, Standard series (Line protection)

### ● AAG series, 2-pole IEC/EN/GB/JIS conformed

Breaker ampere frame	Rated current (A)	Type	■: Rated sensitive current	□: Available mounting and connection
32	5	EW32AAG-2P005	A, B, C	Blank, X, E, Y, P
	10	EW32AAG-2P010		
	15	EW32AAG-2P015		
	20	EW32AAG-2P020		
	30	EW32AAG-2P030		
	32	EW32AAG-2P032		
50	5	EW50AAG-2P005	A, B, C	Blank, X, E, Y, P
	10	EW50AAG-2P010		
	15	EW50AAG-2P015		
	20	EW50AAG-2P020		
	30	EW50AAG-2P030		
	32	EW50AAG-2P032		
	40	EW50AAG-2P040		
	50	EW50AAG-2P050		

### ● EAG series, 2-pole IEC/EN/GB/JIS conformed

Breaker ampere frame	Rated current (A)	Type	■: Rated sensitive current	□: Available mounting and connection
100	50	EW100EAG-2P050	B, K	Blank, X, E, Y, P
	60	EW100EAG-2P060		
	63	EW100EAG-2P063		
	75	EW100EAG-2P075		
	100	EW100EAG-2P100		

### ● AAG series, 3-pole IEC/EN/GB/JIS conformed

Breaker ampere frame	Rated current (A)	Type	■: Rated sensitive current	□: Available mounting and connection
32	5	EW32AAG-3P005	A, B, C	Blank, X, E, Y, P
	10	EW32AAG-3P010		
	15	EW32AAG-3P015		
	20	EW32AAG-3P020		
	30	EW32AAG-3P030		
	32	EW32AAG-3P032		
50	5	EW50AAG-3P005	A, B, C	Blank, X, E, Y, P
	10	EW50AAG-3P010		
	15	EW50AAG-3P015		
	20	EW50AAG-3P020		
	30	EW50AAG-3P030		
	32	EW50AAG-3P032		
	40	EW50AAG-3P040		
	50	EW50AAG-3P050		
100	60	EW100AAG-3P060	B, K	Blank, X, E, Y, P
	63	EW100AAG-3P063		
	75	EW100AAG-3P075		
	100	EW100AAG-3P100		

### ● JAG series, 3-pole IEC/EN/GB/JIS conformed

Breaker ampere frame	Rated current (A)	Type	■: Rated sensitive current	□: Available mounting and connection
125	15	EW125JAG-3P015	B, J	Blank, X, E, P
	20	EW125JAG-3P020		
	30	EW125JAG-3P030		
	40	EW125JAG-3P040		
	50	EW125JAG-3P050		
	60	EW125JAG-3P060		
	75	EW125JAG-3P075		
	100	EW125JAG-3P100		
	125	EW125JAG-3P125		
160	125	EW160JAG-3P125	B, J	Blank, X, E, P
	150	EW160JAG-3P150		
	160	EW160JAG-3P160		
250	175	EW250JAG-3P175	B, J	Blank, X, E, P
	200	EW250JAG-3P200		
	225	EW250JAG-3P225		
	250	EW250JAG-3P250		

Mounting	Connection	□
Front	Front	Blank
Front	Rear	X
Flush	Rear	E
Flush	Top and bottom	Y
Plug-in		P

Rated sensitive current	■
15mA	A
30mA	B
100mA	C
50mA	D
100/300/500/1000mA changeover	J
100/200mA, 100/200/500mA changeover	K
100/200/500/1000mA changeover	K

# Earth Leakage Circuit Breakers

## G-TWIN series

### Type number/Line protection

#### ● EAG series, 3-pole IEC/EN/GB/JIS conformed

Breaker ampere frame	Rated current (A)	Type	■: Rated sensitive current *	□: Available mounting and connection *
32	5	EW32EAG-3P005■□	A, B, C	Blank, X, E, Y, P
	10	EW32EAG-3P010■□		
	15	EW32EAG-3P015■□		
	20	EW32EAG-3P020■□		
	30	EW32EAG-3P030■□		
	32	EW32EAG-3P032■□		
50	5	EW50EAG-3P005■□	A, B, K	Blank, X, E, Y, P
	10	EW50EAG-3P010■□		
	15	EW50EAG-3P015■□		
	20	EW50EAG-3P020■□		
	30	EW50EAG-3P030■□		
	32	EW50EAG-3P032■□		
	40	EW50EAG-3P040■□		
50	EW50EAG-3P050■□			
63	60	EW63EAG-3P060■□	A, B, K	Blank, X, E, Y, P
	63	EW63EAG-3P063■□		
100	50	EW100EAG-3P050■□	B, K	Blank, X, E, Y, P
	60	EW100EAG-3P060■□		
	63	EW100EAG-3P063■□		
	75	EW100EAG-3P075■□		
	100	EW100EAG-3P100■□		
160	125	EW160EAG-3P125■□	B, J	Blank, X, E, P
	150	EW160EAG-3P150■□		
	160	EW160EAG-3P160■□		
250	175	EW250EAG-3P175■□	B, J	Blank, X, E, P
	200	EW250EAG-3P200■□		
	225	EW250EAG-3P225■□		
	250	EW250EAG-3P250■□		
400	250	EW400EAG-3P250■□	B, J	Blank, X, E, P
	300	EW400EAG-3P300■□		
	350	EW400EAG-3P350■□		
	400	EW400EAG-3P400■□		
630	500	EW630EAG-3P500■□	J	Blank, X, E, P
	600	EW630EAG-3P600■□		
	630	EW630EAG-3P630■□		
800	700	EW800EAG-3P700■□	J	Blank, X, E, P
	800	EW800EAG-3P800■□		

#### ● SAG series, 3-pole IEC/EN/GB/JIS conformed

Breaker ampere frame	Rated current (A)	Type	■: Rated sensitive current *	□: Available mounting and connection *
32	3	EW32SAG-3P003■□	B, K	Blank, X, E, Y, P
	5	EW32SAG-3P005■□		
	10	EW32SAG-3P010■□		
	15	EW32SAG-3P015■□		
	20	EW32SAG-3P020■□		
	30	EW32SAG-3P030■□		
	32	EW32SAG-3P032■□		
	50	EW32SAG-3P050■□		
50	5	EW50SAG-3P005■□	B, K	Blank, X, E, Y, P
	10	EW50SAG-3P010■□		
	15	EW50SAG-3P015■□		
	20	EW50SAG-3P020■□		
	30	EW50SAG-3P030■□		
	32	EW50SAG-3P032■□		
	40	EW50SAG-3P040■□		
	50	EW50SAG-3P050■□		
63	60	EW63SAG-3P060■□	B, K	Blank, X, E, Y, P
	63	EW63SAG-3P063■□		
125	15	EW125SAG-3P015■□	B, J	Blank, X, E, P
	20	EW125SAG-3P020■□		
	30	EW125SAG-3P030■□		
	40	EW125SAG-3P040■□		
	50	EW125SAG-3P050■□		
	60	EW125SAG-3P060■□		
	75	EW125SAG-3P075■□		
	100	EW125SAG-3P100■□		
125	EW125SAG-3P125■□			
160	125	EW160SAG-3P125■□	B, J	Blank, X, E, P
	150	EW160SAG-3P150■□		
	160	EW160SAG-3P160■□		
250	175	EW250SAG-3P175■□	B, J	Blank, X, E, P
	200	EW250SAG-3P200■□		
	225	EW250SAG-3P225■□		
	250	EW250SAG-3P250■□		
400	250	EW400SAG-3P250■□	B, J	Blank, X, E, P
	300	EW400SAG-3P300■□		
	350	EW400SAG-3P350■□		
	400	EW400SAG-3P400■□		

\* See page 07/29.

# Earth Leakage Circuit Breakers G-TWIN series Type number/Line protection

### ● RAG series, 3-pole IEC/EN/GB/JIS conformed

Breaker ampere frame	Rated current (A)	Type	■: Rated sensitive current *	□: Available mounting and connection *
50	10	EW50RAG-3P010	B, K	Blank, X, E, Y, P
	15	EW50RAG-3P015		
	20	EW50RAG-3P020		
	30	EW50RAG-3P030		
	32	EW50RAG-3P032		
	40	EW50RAG-3P040		
63	60	EW63RAG-3P060	B, K	Blank, X, E, Y, P
	63	EW63RAG-3P063		
125	15	EW125RAG-3P015	B, J	Blank, X, E, P
	20	EW125RAG-3P020		
	30	EW125RAG-3P030		
	40	EW125RAG-3P040		
	50	EW125RAG-3P050		
	60	EW125RAG-3P060		
	75	EW125RAG-3P075		
	100	EW125RAG-3P100		
160	125	EW160RAG-3P125	B, J	Blank, X, E, P
	150	EW160RAG-3P150		
	160	EW160RAG-3P160		
250	175	EW250RAG-3P175	B, J	Blank, X, E, P
	200	EW250RAG-3P200		
	225	EW250RAG-3P225		
	250	EW250RAG-3P250		
400	250	EW400RAG-3P250	B, J	Blank, X, E, P
	300	EW400RAG-3P300		
	350	EW400RAG-3P350		
	400	EW400RAG-3P400		
630	500	EW630RAG-3P500	J	Blank, X, E, P
	600	EW630RAG-3P600		
	630	EW630RAG-3P630		
800	700	EW800RAG-3P700	J	Blank, X, E, P
	800	EW800RAG-3P800		

### ● HAG series, 3-pole IEC/EN/GB/JIS conformed

Breaker ampere frame	Rated current (A)	Type	■: Rated sensitive current *	□: Available mounting and connection *
400	250	EW400HAG-3P250	B, J	Blank, X, E, P
	300	EW400HAG-3P300		
	350	EW400HAG-3P350		
	400	EW400HAG-3P400		
630	500	EW630HAG-3P500	J	Blank, X, E, P
	600	EW630HAG-3P600		
	630	EW630HAG-3P630		
800	700	EW800HAG-3P700	J	Blank, X, E, P
	800	EW800HAG-3P800		

### ● JAG series, 4-pole IEC/EN/GB/JIS conformed

Breaker ampere frame	Rated current (A)	Type	■: Rated sensitive current *	□: Available mounting and connection *
125	15	EW125JAG-4P015	B, J	Blank, X, E
	20	EW125JAG-4P020		
	30	EW125JAG-4P030		
	40	EW125JAG-4P040		
	50	EW125JAG-4P050		
	60	EW125JAG-4P060		
	75	EW125JAG-4P075		
	100	EW125JAG-4P100		
160	125	EW160JAG-4P125	B, J	Blank, X, E
	150	EW160JAG-4P150		
	160	EW160JAG-4P160		
250	175	EW250JAG-4P175	B, J	Blank, X, E
	200	EW250JAG-4P200		
	225	EW250JAG-4P225		
	250	EW250JAG-4P250		

### ● SAG series, 4-pole IEC/EN/GB/JIS conformed

Breaker ampere frame	Rated current (A)	Type	■: Rated sensitive current *	□: Available mounting and connection *
125	15	EW125SAG-4P015	B, J	Blank, X, E
	20	EW125SAG-4P020		
	30	EW125SAG-4P030		
	40	EW125SAG-4P040		
	50	EW125SAG-4P050		
	60	EW125SAG-4P060		
	75	EW125SAG-4P075		
	100	EW125SAG-4P100		
	125	EW125SAG-4P125		
	160	125		
150		EW160SAG-4P150		
160		EW160SAG-4P160		
250	175	EW250SAG-4P175	B, J	Blank, X, E
	200	EW250SAG-4P200		
	225	EW250SAG-4P225		

\* See page 07/29.

# Earth Leakage Circuit Breakers

## G-TWIN series

### Type number/Line protection

#### ● RAG series, 4-pole IEC/EN/GB/JIS conformed

Breaker ampere frame	Rated current (A)	Type	■: Rated sensitive current *	□: Available mounting and connection *
125	15	EW125RAG-4P015■□	B, J	Blank, X, E
	20	EW125RAG-4P020■□		
	30	EW125RAG-4P030■□		
	40	EW125RAG-4P040■□		
	50	EW125RAG-4P050■□		
	60	EW125RAG-4P060■□		
	75	EW125RAG-4P075■□		
	100	EW125RAG-4P100■□		
	125	EW125RAG-4P125■□		
160	125	EW160RAG-4P125■□	B, J	Blank, X, E
	150	EW160RAG-4P150■□		
	160	EW160RAG-4P160■□		
250	175	EW250RAG-4P175■□	B, J	Blank, X, E
	200	EW250RAG-4P200■□		
	225	EW250RAG-4P225■□		
400	250	EW400RAG-4P250■□	B, J	Blank, X, E
	300	EW400RAG-4P300■□		
	350	EW400RAG-4P350■□		
	400	EW400RAG-4P400■□		

#### ● HAG series, 4-pole IEC/EN/GB/JIS conformed

Breaker ampere frame	Rated current (A)	Type	■: Rated sensitive current *	□: Available mounting and connection*
400	250	EW400HAG-4P250■□	B, J	Blank, X, E
	300	EW400HAG-4P300■□		
	350	EW400HAG-4P350■□		
	400	EW400HAG-4P400■□		

\* See page 07/29.



# Earth Leakage Circuit Breakers

## G-TWIN series

### Type number/Line protection

#### ■ Type number, Global series (Line protection)

##### ● EAGU series, 2-pole UL489 Listed

Breaker ampere frame	Rated current (A)	Type	■: Rated sensitive current *	□: Available mounting and connection
100	60	EW100EAGU-2P060	■ □	B, K Blank, SF, S3, S4
	63	EW100EAGU-2P063	■ □	
	70	EW100EAGU-2P070	■ □	
	75	EW100EAGU-2P075	■ □	
	80	EW100EAGU-2P080	■ □	
	90	EW100EAGU-2P090	■ □	
	100	EW100EAGU-2P100	■ □	

##### ● EAGU series, 3-pole UL489 Listed

Breaker ampere frame	Rated current (A)	Type	■: Rated sensitive current *	□: Available mounting and connection
100	60	EW100EAGU-3P060	■ □	B,D, K Blank, SF, S3, S4
	63	EW100EAGU-3P063	■ □	
	70	EW100EAGU-3P070	■ □	
	75	EW100EAGU-3P075	■ □	
	80	EW100EAGU-3P080	■ □	
	90	EW100EAGU-3P090	■ □	
	100	EW100EAGU-3P100	■ □	

##### ● JAGU series, 3-pole UL489 Listed

Breaker ampere frame	Rated current (A)	Type	■: Rated sensitive current *	□: Available mounting and connection
125	15	EW125JAGU-3P015	■ □	B, K Blank, SB, SF, S3 S4, S5, S6, S7, S8
	20	EW125JAGU-3P020	■ □	
	30	EW125JAGU-3P030	■ □	
	40	EW125JAGU-3P040	■ □	
	50	EW125JAGU-3P050	■ □	
	60	EW125JAGU-3P060	■ □	
	75	EW125JAGU-3P075	■ □	
	100	EW125JAGU-3P100	■ □	
	125	EW125JAGU-3P125	■ □	
	250	125	EW250JAGU-3P125	
150		EW250JAGU-3P150	■ □	
160		EW250JAGU-3P160	■ □	
175		EW250JAGU-3P175	■ □	
200		EW250JAGU-3P200	■ □	
225		EW250JAGU-3P225	■ □	
250		EW250JAGU-3P250	■ □	

##### ● SAGU series, 3-pole UL489 Listed

Breaker ampere frame	Rated current (A)	Type	■: Rated sensitive current *	□: Available mounting and connection
400	250	EW400SAGU-3P250	■ □	B, K Blank, SB, S7, S8
	300	EW400SAGU-3P300	■ □	
	350	EW400SAGU-3P350	■ □	
	400	EW400SAGU-3P400	■ □	

##### ● RAGU series, 3-pole UL489 Listed

Breaker ampere frame	Rated current (A)	Type	■: Rated sensitive current *	□: Available mounting and connection
50	3	EW50RAGU-3P003	■ □	B, D, K Blank, SF, S3, S4
	5	EW50RAGU-3P005	■ □	
	10	EW50RAGU-3P010	■ □	
	15	EW50RAGU-3P015	■ □	
	20	EW50RAGU-3P020	■ □	
	30	EW50RAGU-3P030	■ □	
	32	EW50RAGU-3P032	■ □	
	40	EW50RAGU-3P040	■ □	
	50	EW50RAGU-3P050	■ □	
	125	15	EW125RAGU-3P015	
20		EW125RAGU-3P020	■ □	
30		EW125RAGU-3P030	■ □	
40		EW125RAGU-3P040	■ □	
50		EW125RAGU-3P050	■ □	
60		EW125RAGU-3P060	■ □	
75		EW125RAGU-3P075	■ □	
250	125	EW250RAGU-3P125	■ □	B, K Blank, SB, SF, S3 S4, S5, S6, S7, S8
	150	EW250RAGU-3P150	■ □	
	160	EW250RAGU-3P160	■ □	
	175	EW250RAGU-3P175	■ □	
	200	EW250RAGU-3P200	■ □	
	225	EW250RAGU-3P225	■ □	
	250	EW250RAGU-3P250	■ □	
400	250	EW400RAGU-3P250	■ □	B, K Blank, SB, S7, S8
	300	EW400RAGU-3P300	■ □	
	350	EW400RAGU-3P350	■ □	
	400	EW400RAGU-3P400	■ □	
630	500	EW630RAGU-3P500	■ □	K Blank, SB, S7, S8
	600	EW630RAGU-3P600	■ □	
	630	EW630RAGU-3P630	■ □	

##### ● HAGU series, 3-pole UL489 Listed

Breaker ampere frame	Rated current (A)	Type	■: Rated sensitive current *	□: Available mounting and connection
400	250	EW400HAGU-3P250	■ □	B, K Blank, SB, S7, S8
	300	EW400HAGU-3P300	■ □	
	350	EW400HAGU-3P350	■ □	
	400	EW400HAGU-3P400	■ □	

#### Terminal combination

Code	Terminal position		Breaker type		
	Line	Load	EW50, 100	EW125,250	EW400,630
Blank	Screw	Screw	●	●	-
Blank	Flat terminal	Flat terminal	-	-	●
SB	Block terminal	Block terminal	-	●	●
SF	Flat terminal	Flat terminal	●	●	-
S3	Screw	Flat terminal	●	●	-
S4	Flat terminal	Screw	●	●	-
S5	Screw	Block terminal	-	●	-
S6	Block terminal	Screw	-	●	-
S7	Flat terminal	Block terminal	-	●	●
S8	Block terminal	Flat terminal	-	●	●

\* See page 07/29.

# Earth Leakage Circuit Breakers

## G-TWIN series

### Type number/Motor protection

#### ■ Type number, Standard series (Motor protection)

##### ● EAM series, 3-pole IEC/EN/GB/JIS conformed

Breaker ampere frame	Rated current (A)	Type	■: Rated sensitive current	□: Available mounting and connection
32	1.4	EW32EAM-3P1P4 <input type="checkbox"/>	B, C	Blank, X, E, Y, P
	2.6	EW32EAM-3P2P6 <input type="checkbox"/>		
	4	EW32EAM-3P004 <input type="checkbox"/>		
	5	EW32EAM-3P005 <input type="checkbox"/>		
	8	EW32EAM-3P008 <input type="checkbox"/>		
	10	EW32EAM-3P010 <input type="checkbox"/>		
	16	EW32EAM-3P016 <input type="checkbox"/>		
	24	EW32EAM-3P024 <input type="checkbox"/>		
32	EW32EAM-3P032 <input type="checkbox"/>			
50	45	EW50EAM-3P045 <input type="checkbox"/>	B, K	Blank, X, E, Y, P
63	63	EW63EAM-3P063 <input type="checkbox"/>	B, K	Blank, X, E, Y, P
100	63	EW100EAM-3P063 <input type="checkbox"/>	B, K	Blank, X, E, Y, P
	75	EW100EAM-3P075 <input type="checkbox"/>		
	90	EW100EAM-3P090 <input type="checkbox"/>		
	100	EW100EAM-3P100 <input type="checkbox"/>		
250	125	EW250EAM-3P125 <input type="checkbox"/>	B, K	Blank, X, E, P
	150	EW250EAM-3P150 <input type="checkbox"/>		
	175	EW250EAM-3P175 <input type="checkbox"/>		
	225	EW250EAM-3P225 <input type="checkbox"/>		

##### ● JAM series, 3-pole IEC/EN/GB/JIS conformed

Breaker ampere frame	Rated current (A)	Type	■: Rated sensitive current	□: Available mounting and connection
125	75	EW125JAM-3P075 <input type="checkbox"/>	B, K	Blank, X, E, P
	90	EW125JAM-3P090 <input type="checkbox"/>		
250	125	EW250JAM-3P125 <input type="checkbox"/>	B, K	Blank, X, E, P
	150	EW250JAM-3P150 <input type="checkbox"/>		
	175	EW250JAM-3P175 <input type="checkbox"/>		
	225	EW250JAM-3P225 <input type="checkbox"/>		

\* See page 07/29.

Mounting	Connection	□
Front	Front	Blank
Front	Rear	X
Flush	Rear	E
Flush	Top and bottom	Y
Plug-in		P

##### ● SAM series, 3-pole IEC/EN/GB/JIS conformed

Breaker ampere frame	Rated current (A)	Type	■: Rated sensitive current	□: Available mounting and connection		
32	0.7	EW32SAM-3P0P7 <input type="checkbox"/>	B, K	Blank, X, E, Y, P		
	1.4	EW32SAM-3P1P4 <input type="checkbox"/>				
	2	EW32SAM-3P002 <input type="checkbox"/>				
	2.6	EW32SAM-3P2P6 <input type="checkbox"/>				
	4	EW32SAM-3P004 <input type="checkbox"/>				
	5	EW32SAM-3P005 <input type="checkbox"/>				
	8	EW32SAM-3P008 <input type="checkbox"/>				
	10	EW32SAM-3P010 <input type="checkbox"/>				
	12	EW32SAM-3P012 <input type="checkbox"/>				
	16	EW32SAM-3P016 <input type="checkbox"/>				
	24	EW32SAM-3P024 <input type="checkbox"/>				
	32	EW32SAM-3P032 <input type="checkbox"/>				
	50	0.7			EW50SAM-3P0P7 <input type="checkbox"/>	B, K
1.4		EW50SAM-3P1P4 <input type="checkbox"/>				
2		EW50SAM-3P002 <input type="checkbox"/>				
2.6		EW50SAM-3P2P6 <input type="checkbox"/>				
4		EW50SAM-3P004 <input type="checkbox"/>				
5		EW50SAM-3P005 <input type="checkbox"/>				
8		EW50SAM-3P008 <input type="checkbox"/>				
10		EW50SAM-3P010 <input type="checkbox"/>				
12		EW50SAM-3P012 <input type="checkbox"/>				
16		EW50SAM-3P016 <input type="checkbox"/>				
63	24	EW50SAM-3P024 <input type="checkbox"/>	B, K	Blank, X, E, Y, P		
	32	EW50SAM-3P032 <input type="checkbox"/>				
	40	EW50SAM-3P040 <input type="checkbox"/>				
	45	EW50SAM-3P045 <input type="checkbox"/>				
	63	EW63SAM-3P063 <input type="checkbox"/>				

##### ● RAM series, 3-pole IEC/EN/GB/JIS conformed

Breaker ampere frame	Rated current (A)	Type	■: Rated sensitive current	□: Available mounting and connection
125	45	EW125RAM-3P045 <input type="checkbox"/>	B, K	Blank, X, E, P
	60	EW125RAM-3P060 <input type="checkbox"/>		
	75	EW125RAM-3P075 <input type="checkbox"/>		
	90	EW125RAM-3P090 <input type="checkbox"/>		
250	125	EW250RAM-3P125 <input type="checkbox"/>	B, K	Blank, X, E, P
	150	EW250RAM-3P150 <input type="checkbox"/>		
	175	EW250RAM-3P175 <input type="checkbox"/>		
	225	EW250RAM-3P225 <input type="checkbox"/>		

Rated sensitive current	■
30mA	B
100mA	C
100/200mA changeover	K
100/200/500mA changeover	K
100/200/500/1000mA changeover	K

# Earth Leakage Circuit Breakers G-TWIN series Arc space

## ■ Arc space, mm

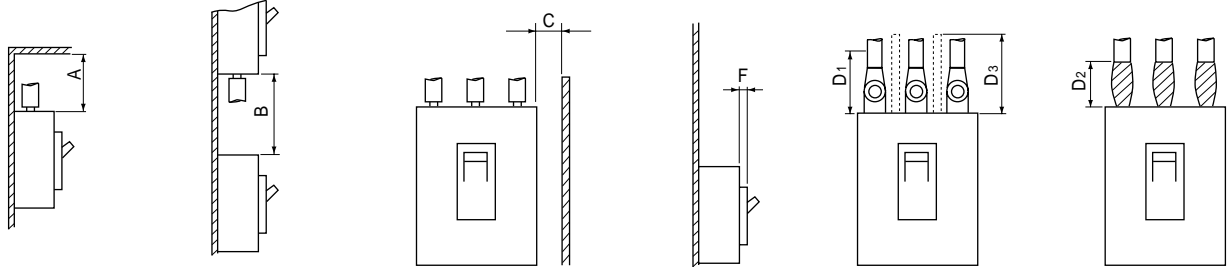

Frame size	ELCB basic type	Ceiling distance		Vertical distance		Side plate distance		Front plate distance				Taping		Barrier
		A		B		C		Painted		No painted		Crimp type terminal lug	Bus-bar	
		440V	230V	440V	230V	440V	230V	440V	230V	440V	230V			
32A	EW32A	–	10	–	10	–	10	–	0	–	0	Exposed live part dimension +20	10	10
	EW32E	10	10	30	10	20	15	0	0	0	0		30	30
	EW32S	10	10	30	30	20	15	0	0	0	0		30	30
50A	EW50A	–	10	–	10	–	10	–	0	–	0		10	10
	EW50E	10	10	30	30	25	15	0	0	0	0		30	30
	EW50S	30	10	40	40	25	15	0	0	0	0		30	30
	EW50R	50	25	50	50	25	15	0	0	10	5		50	50
63A	EW63E	10	10	30	30	25	15	0	0	0	0		30	30
	EW63S	30	10	40	40	25	15	0	0	0	0		30	30
	EW63R	50	25	50	50	25	15	0	0	10	5		50	50
100A	EW100A	–	10	–	20	–	15	–	0	–	0		50	50
	EW100E	50	25	50	50	25	15	0	0	10	5		50	50
125A	EW125J	40	40	50	50	25	20	0	0	10	5	50	50	
	EW125S	40	40	60	60	25	20	5	0	10	5	50	50	
	EW125R	40	40	60	60	25	20	5	0	10	5	50	50	
160A	EW160E	40	40	50	50	50	15	0	0	10	5	80	80	
	EW160J	40	40	60	60	50	20	0	0	10	5	80	80	
	EW160S	40	40	80	80	50	20	5	0	10	10	80	80	
	EW160R	40	40	80	80	50	20	5	0	10	10	80	80	
250A	EW250E	40	40	50	50	50	15	0	0	10	5	80	80	
	EW250J	40	40	60	60	50	20	0	0	10	5	80	80	
	EW250S	40	40	80	80	50	20	5	0	10	10	80	80	
	EW250R	40	40	80	80	50	20	5	0	10	10	80	80	
400A	EW400E	100	80	100	80	50	20	0	0	10	5	100	100	
	EW400S	100	80	100	80	50	20	0	0	10	5	100	100	
	EW400R	100	80	100	80	80	40	5	0	20	10	100	100	
	EW400H	100	80	100	80	80	40	5	0	20	10	100	100	
630A	EW630E	100	80	100	80	80	40	0	0	10	5	100	100	
	EW630R	100	80	100	80	80	40	5	0	20	10	100	100	
	EW630H	120	100	120	100	80	40	5	0	20	10	120	120	
800A	EW800E	100	80	100	80	80	40	0	0	10	5	100	100	
	EW800R	100	80	100	80	80	40	5	0	20	10	100	100	
	EW800H	120	100	120	100	80	40	5	0	20	20	120	120	

07

# Earth Leakage Circuit Breakers

## G-TWIN series

### Dimensions / Standard

■ Dimensions, mm

● Front mounting, front connection

EW32□-2P, EW50□-2P

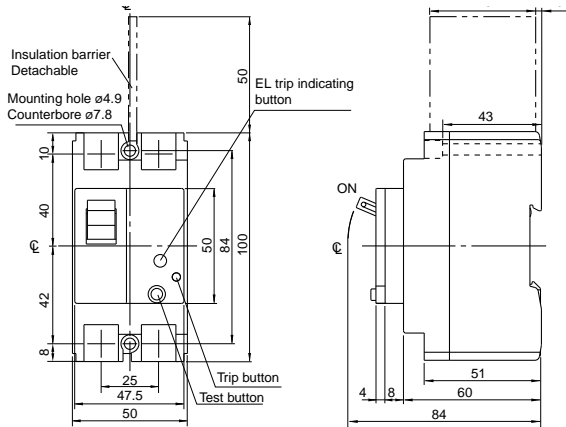

Panel drilling

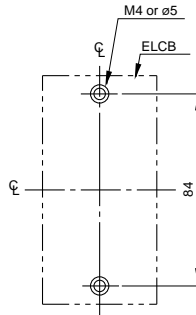

Front panel cutting

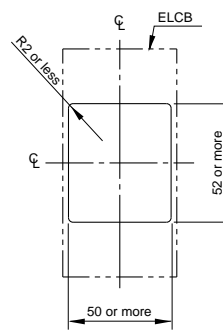

Terminal section

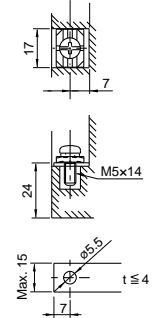

Insulation barriers  
Standard provided: EW50SAG, EW50RAG  
Optional: EW32AAG, EW50EAG

EW32□-3P, EW50□-3P

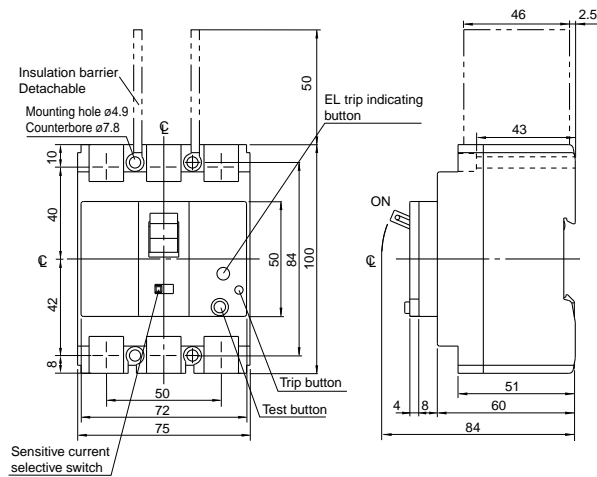

Panel drilling

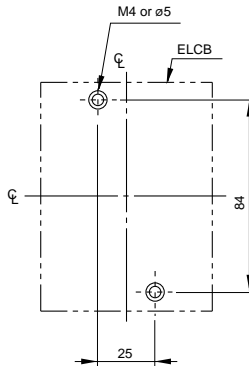

Front panel cutting

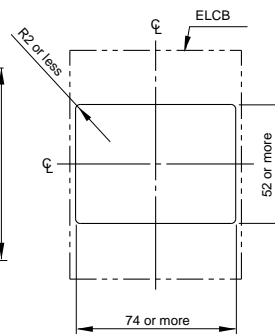

Terminal section

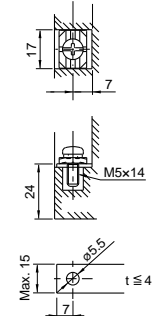

Insulation barriers  
Standard provided: EW50SAG, EW50RAG  
Optional: EW32AAG, EW32SAG, EW50EAG

EW63□-3P

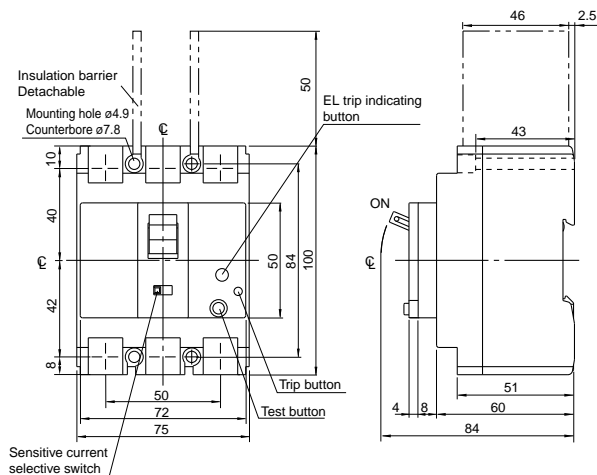

Panel drilling

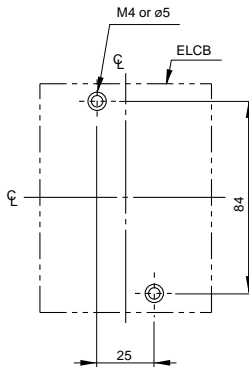

Front panel cutting

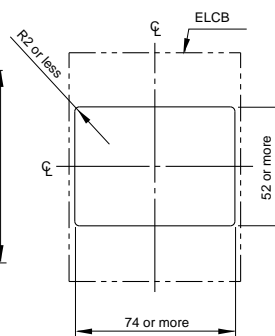

Terminal section

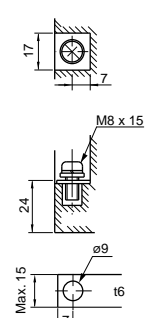

# Earth Leakage Circuit Breakers G-TWIN series Dimensions / Standard

- Dimensions, mm
- Front mounting, front connection

## EW100□-2P, 3P

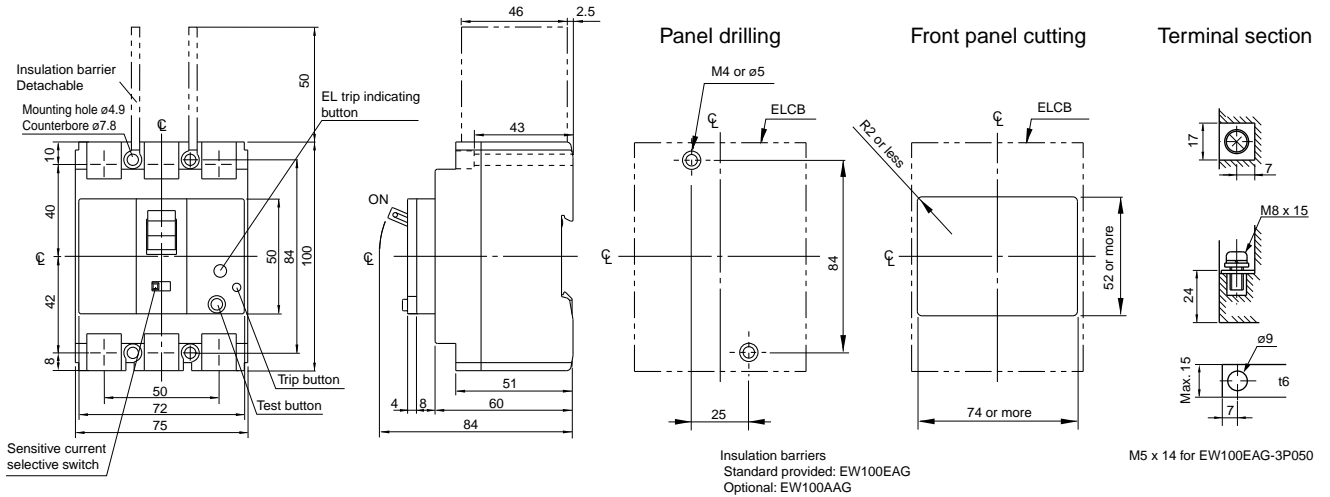

## EW125□-3P

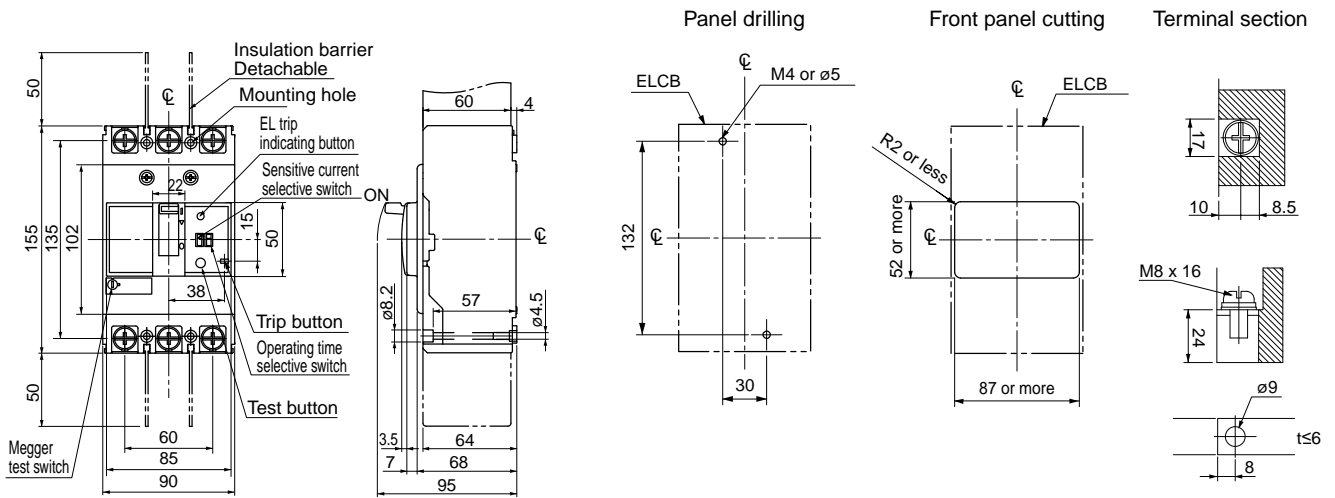

07

# Earth Leakage Circuit Breakers

## G-TWIN series

### Dimensions / Standard

■ Dimensions, mm

● Front mounting, front connection

EW125□-4P

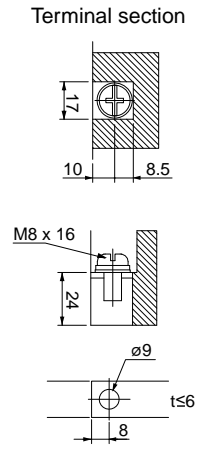
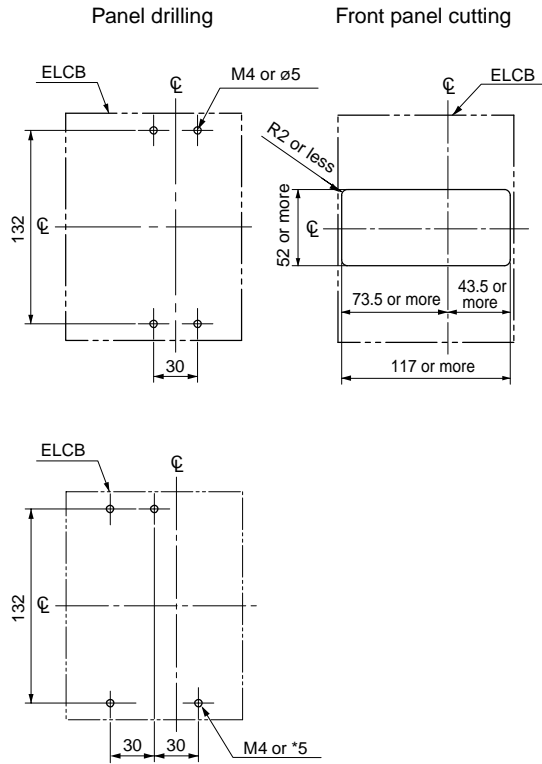
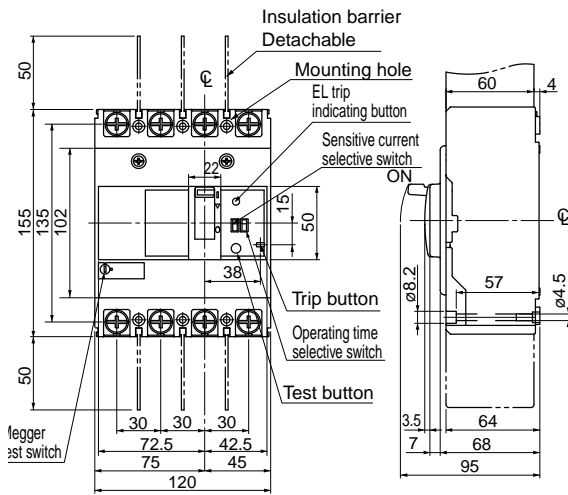

For N, V type handle

# Earth Leakage Circuit Breakers

## G-TWIN series

### Dimensions / Standard

■ Dimensions, mm

● Front mounting, front connection

EW160□-3P

EW250□-3P

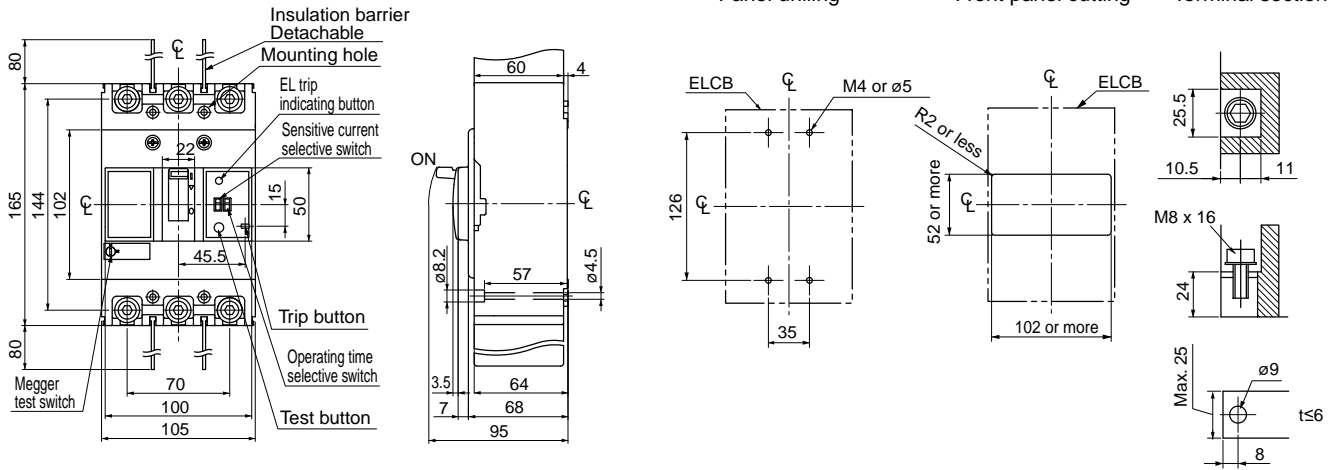

EW160□-4P

EW250□-4P

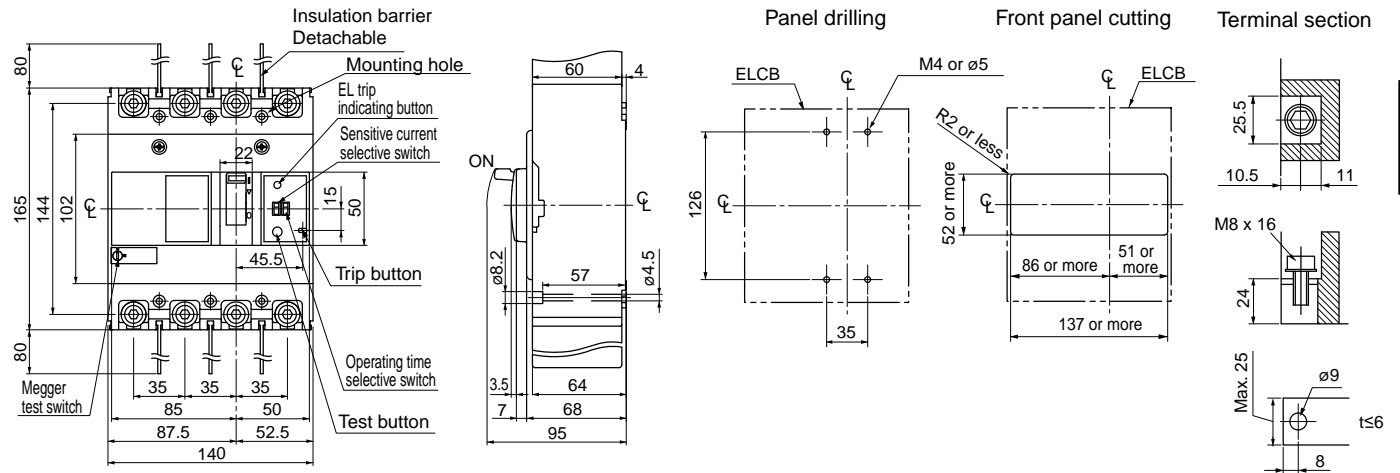

07

# Earth Leakage Circuit Breakers

## G-TWIN series

### Dimensions / Standard

■ Dimensions, mm

- Front mounting, front connection

EW400□-3P

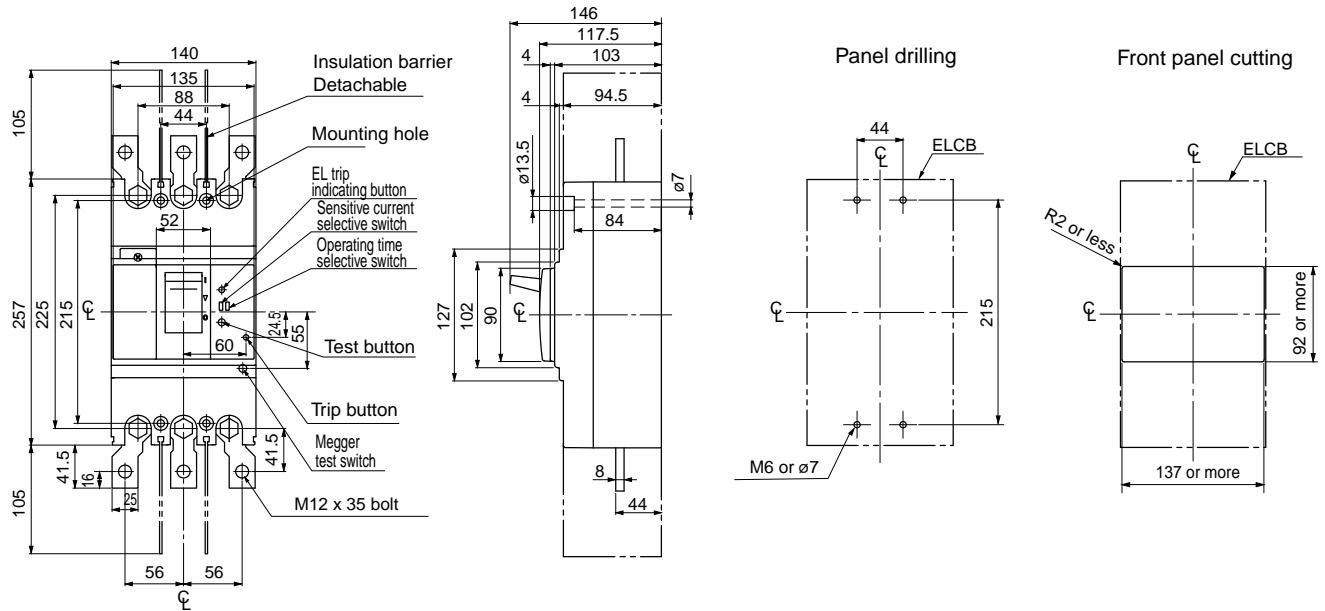

EW400□-4P

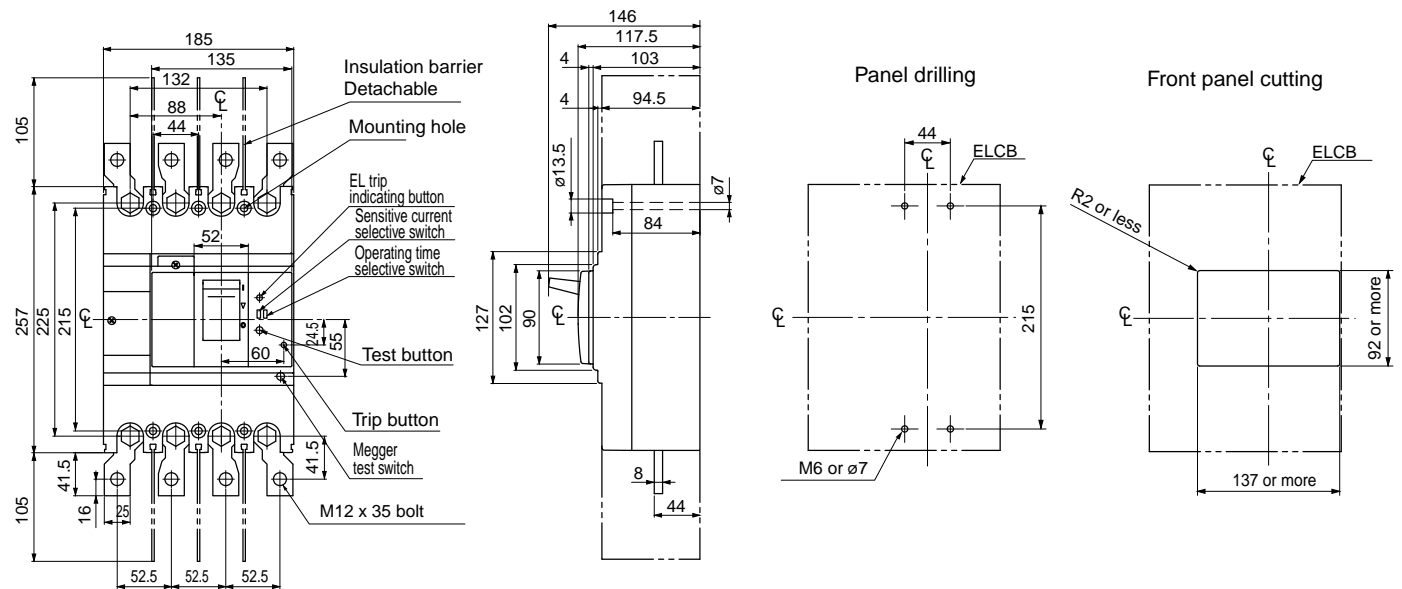



# Earth Leakage Circuit Breakers G-TWIN series Dimensions / Standard

## ■ Dimensions, mm

### ● Front mounting, front connection

#### EW630□-3P

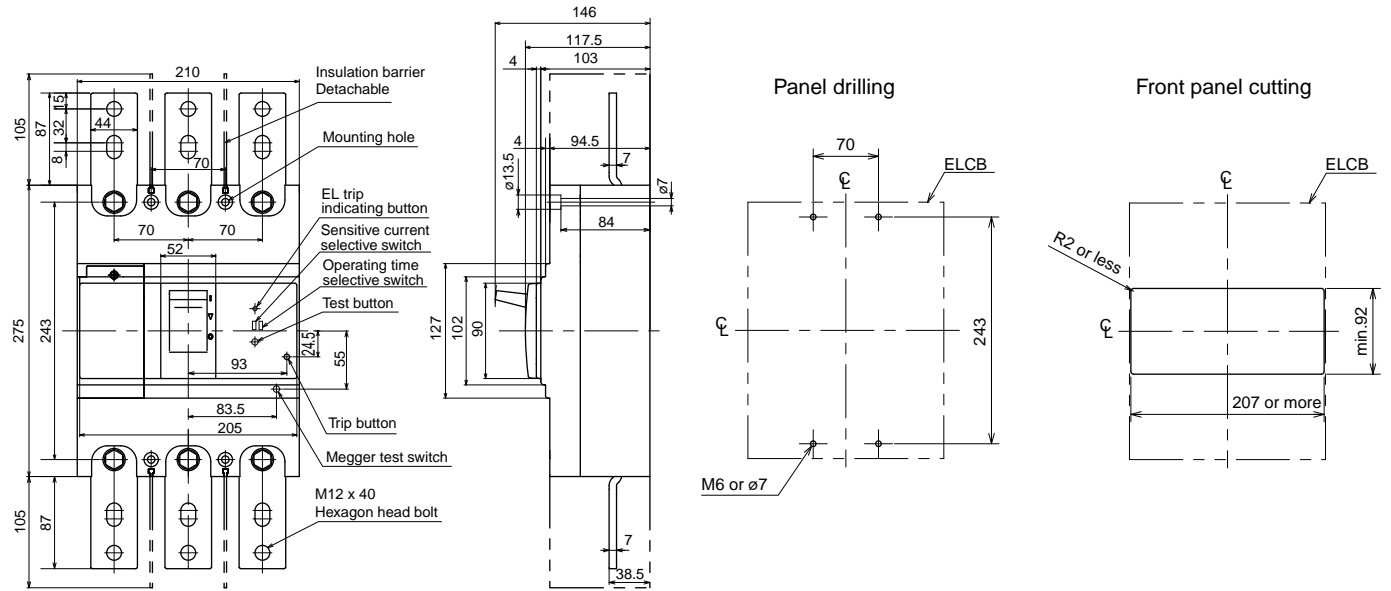

#### EW800□-3P

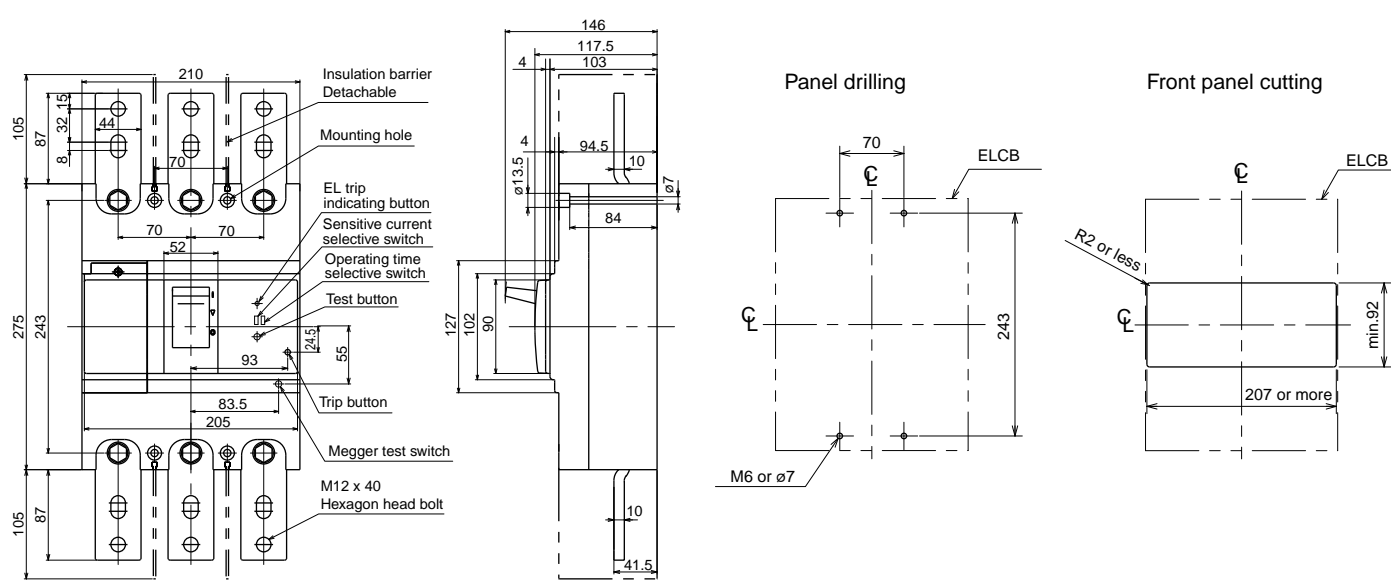

# Earth Leakage Circuit Breakers

## G-TWIN series

### Dimensions / Standard

#### ■ Dimensions, mm

#### ● Front mounting, rear connection (type X)

#### EW32□-2P, EW50□-2P

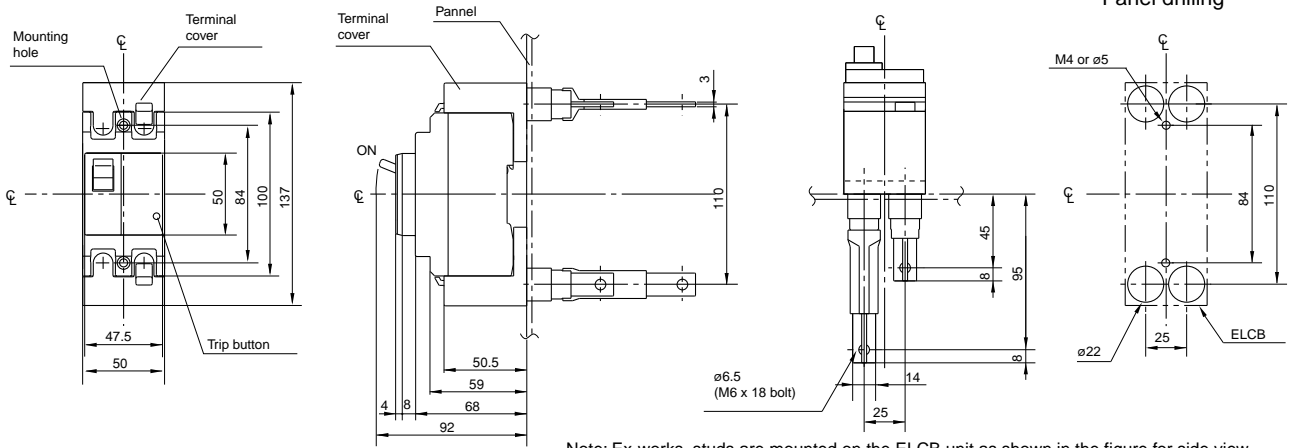

Note: Ex-works, studs are mounted on the ELCB unit as shown in the figure for side view.  
 •Studs for line side terminal : Mounted horizontally.  
 •Studs for load-side terminal : Mounted vertically.  
 Each stud can be turned by 90°.

#### EW32□-3P, EW50□-3P

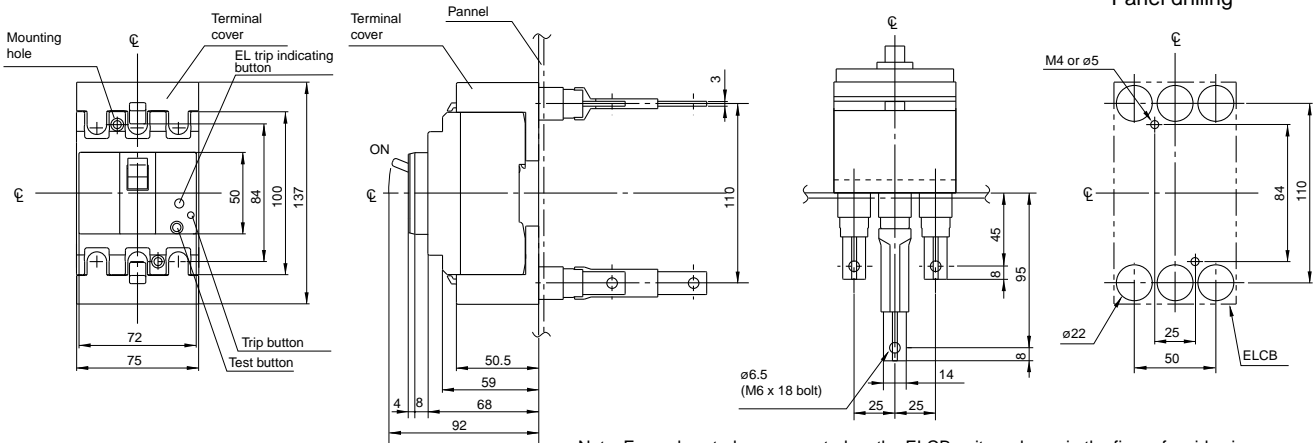

Note: Ex-works, studs are mounted on the ELCB unit as shown in the figure for side view.  
 •Studs for line side terminal : Mounted horizontally.  
 •Studs for load-side terminal : Mounted vertically.  
 Each stud can be turned by 90°.  
 2-pole breaker is supplied in 3-pole frame with current carrying parts omitted from center pole.

#### EW63□-3P

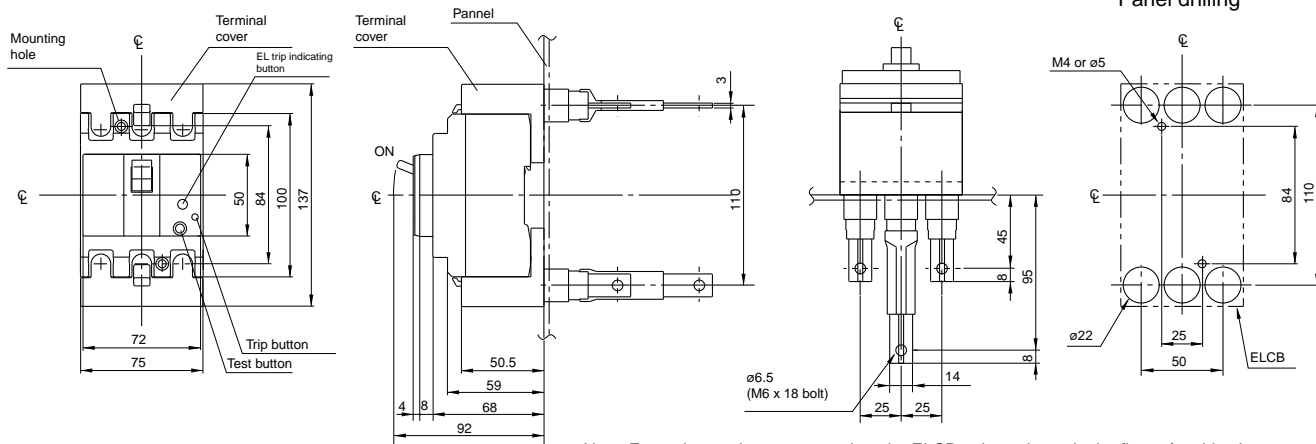

Note: Ex-works, studs are mounted on the ELCB unit as shown in the figure for side view.  
 •Studs for line side terminal : Mounted horizontally.  
 •Studs for load-side terminal : Mounted vertically.  
 Each stud can be turned by 90°.  
 2-pole breaker is supplied in 3-pole frame with current carrying parts omitted from center pole.

# Earth Leakage Circuit Breakers G-TWIN series Dimensions / Standard

■ Dimensions, mm

● Front mounting, rear connection (type X)

**EW100□-2P,3P**

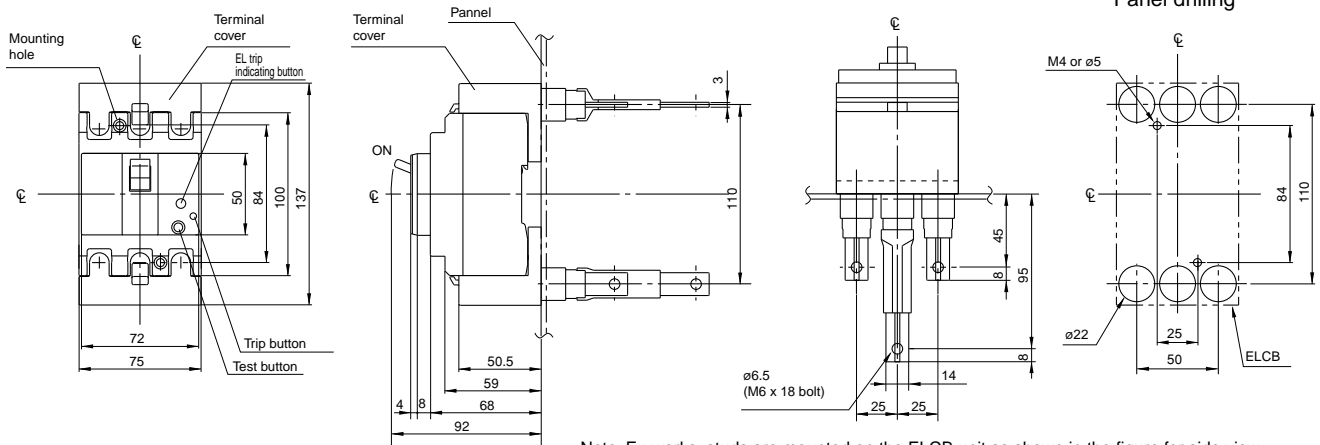

Note: Ex-works, studs are mounted on the ELCB unit as shown in the figure for side view.  
 •Studs for line side terminal : Mounted horizontally.  
 •Studs for load-side terminal : Mounted vertically.  
 Each stud can be turned by 90°.  
 2-pole breaker is supplied in 3-pole frame with current carrying parts omitted from center pole.

**EW125□-3P**

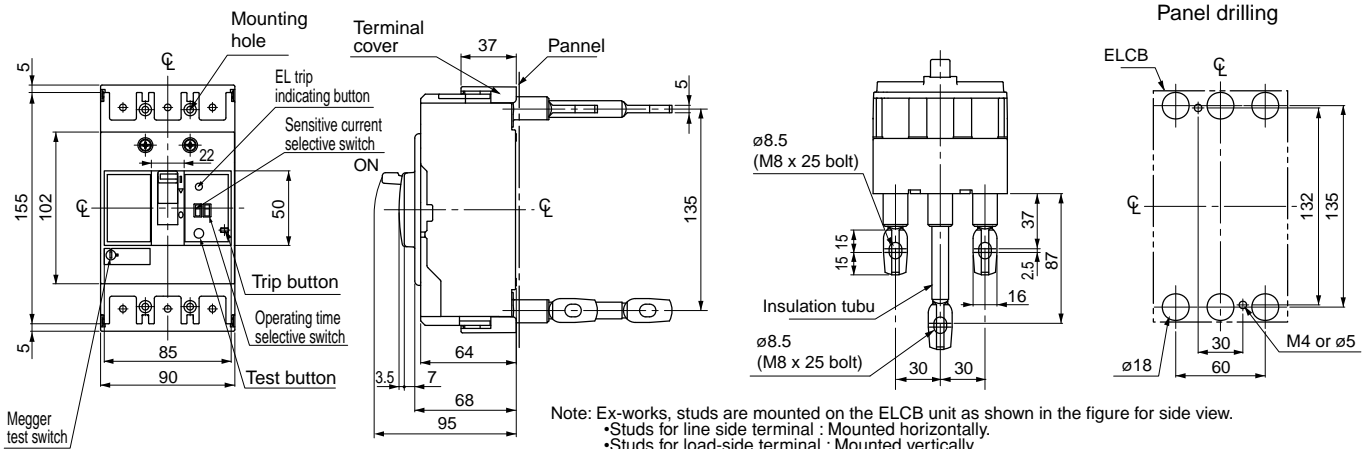

Note: Ex-works, studs are mounted on the ELCB unit as shown in the figure for side view.  
 •Studs for line side terminal : Mounted horizontally.  
 •Studs for load-side terminal : Mounted vertically.  
 Each stud can be turned by 90°.

# Earth Leakage Circuit Breakers

## G-TWIN series

### Dimensions / Standard

■ Dimensions, mm

● Front mounting, rear connection (type X)

EW125□-4P

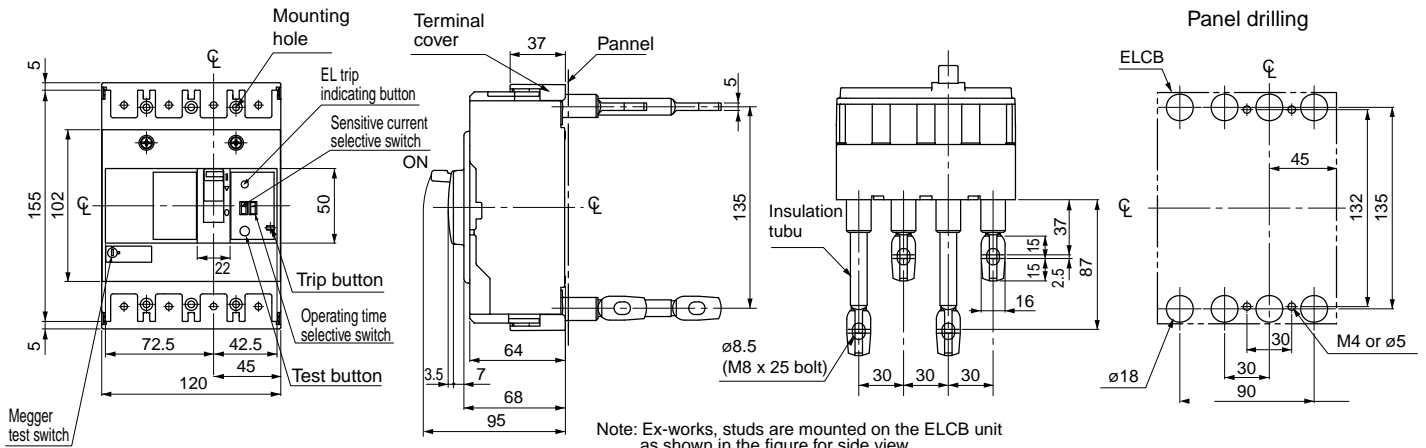

Note: Ex-works, studs are mounted on the ELCB unit as shown in the figure for side view.  
 •Studs for line side terminal : Mounted horizontally.  
 •Studs for load-side terminal : Mounted vertically.  
 Each stud can be turned by 90°.

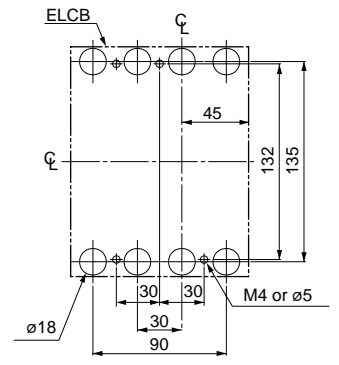

For V, N type handle



# Earth Leakage Circuit Breakers

## G-TWIN series

### Dimensions / Standard

#### ■ Dimensions, mm

#### ● Front mounting, rear connection (type X)

#### EW400□-3P

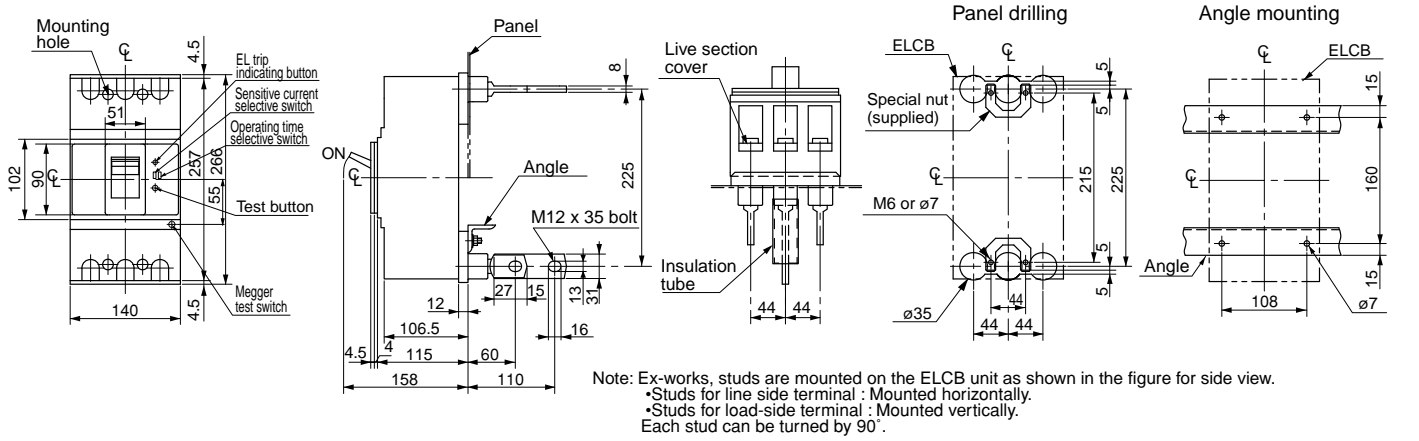

#### EW400□-4P

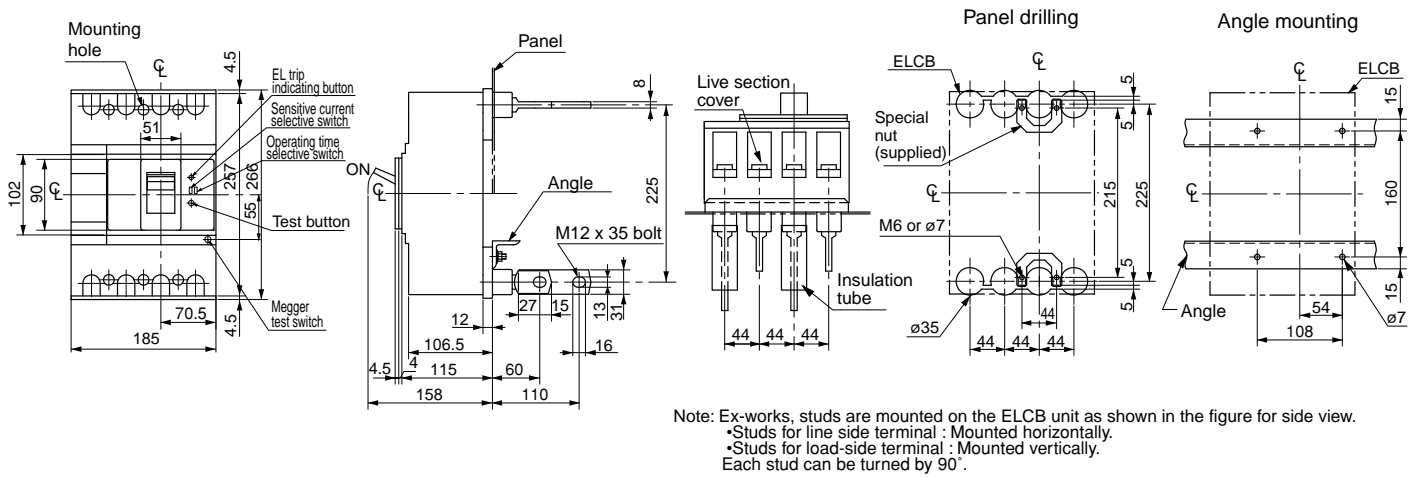

# Earth Leakage Circuit Breakers G-TWIN series Dimensions / Standard

- Dimensions, mm
  - Front mounting, rear connection (type X)
- EW630□-3P**

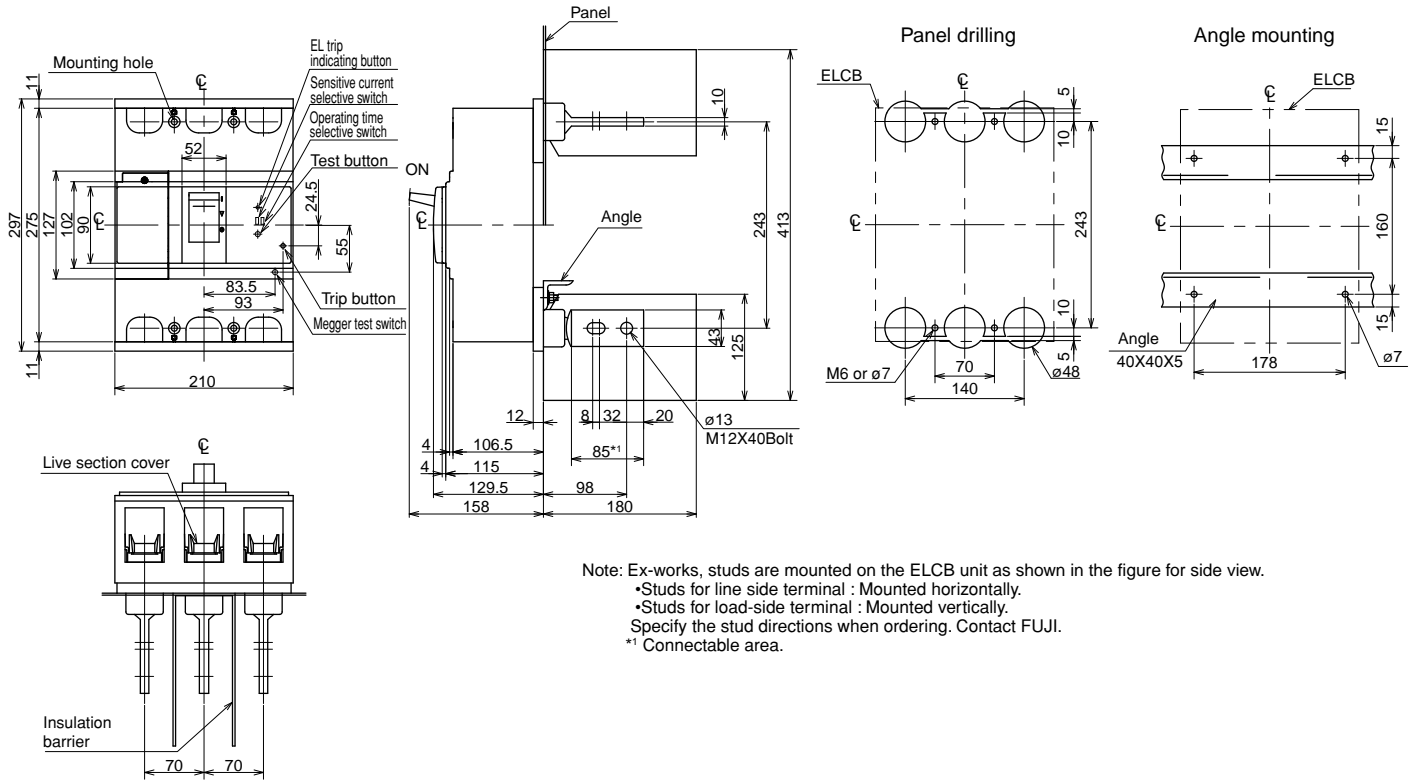

**EW800□-3P**

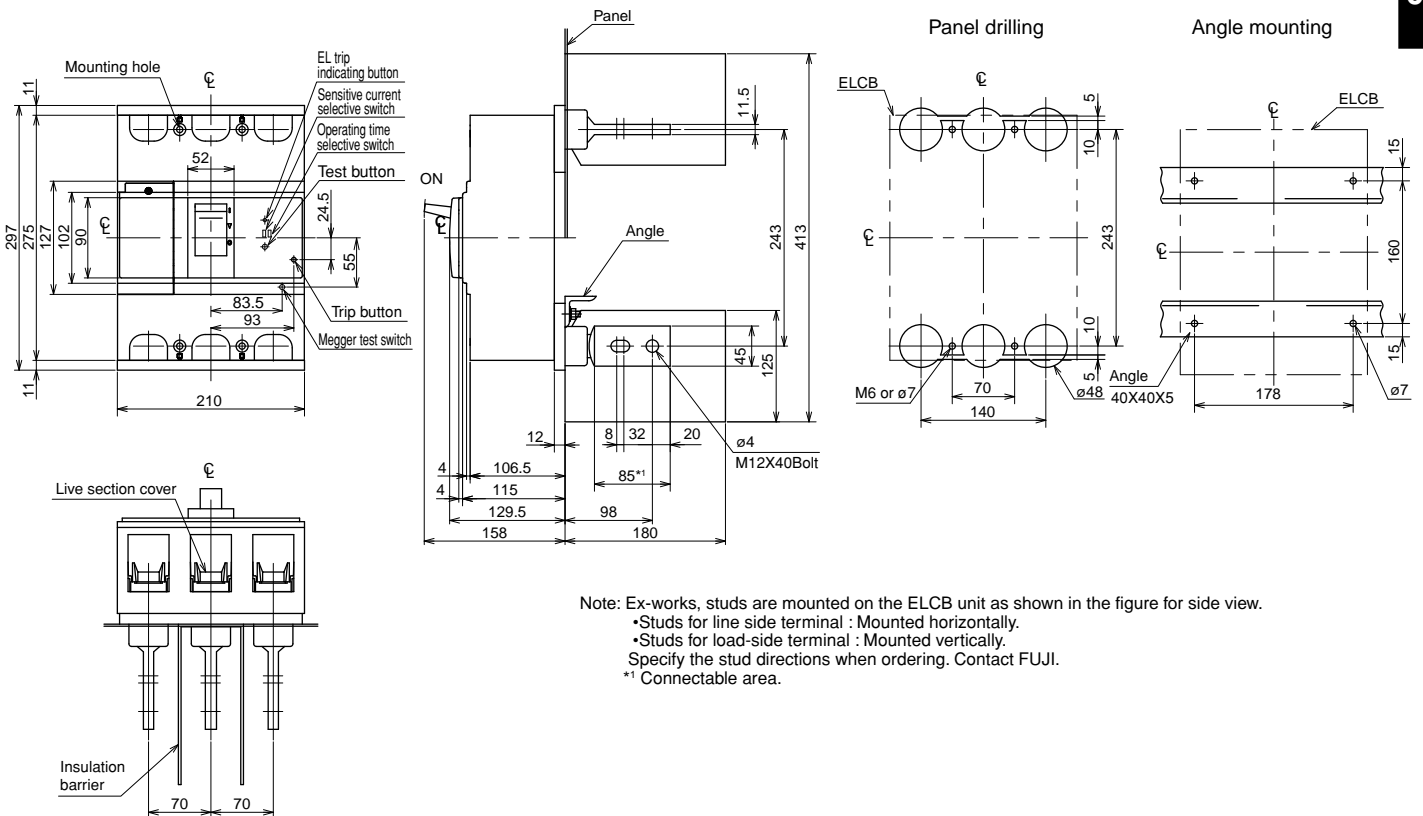

**07**

# Earth Leakage Circuit Breakers

## G-TWIN series

### Dimensions / Global

■ Dimensions, mm

- Front mounting, front connection

#### EW50RAGU-3P

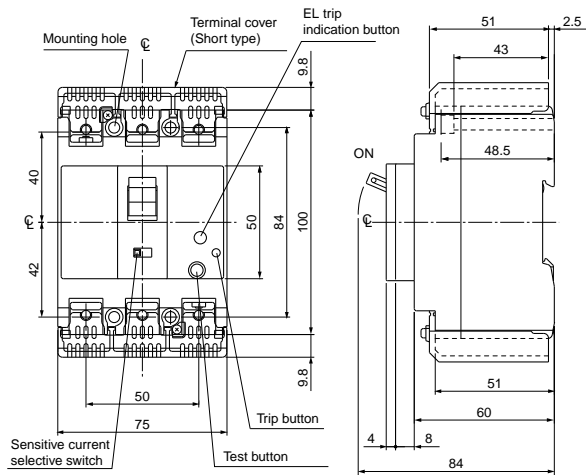

Panel drilling

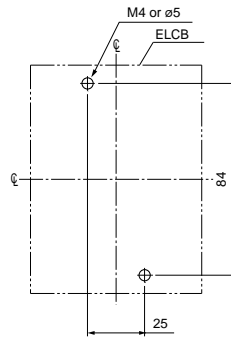

Front panel cutting

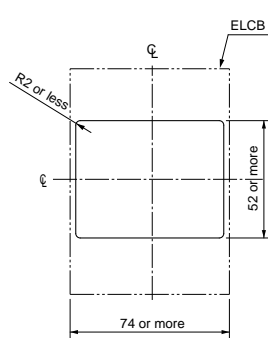

Terminal section

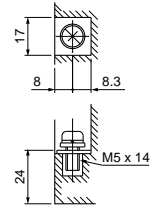

#### EW100EAGU-2P, -3P

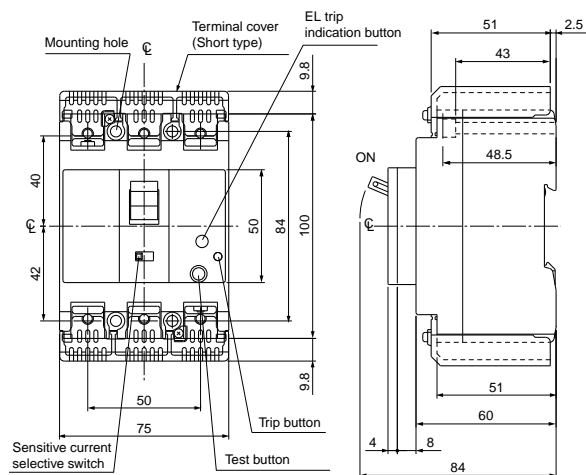

Panel drilling

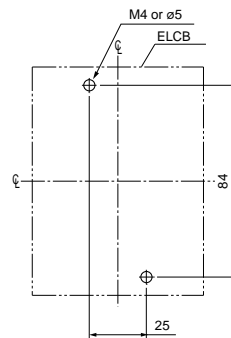

Front panel cutting

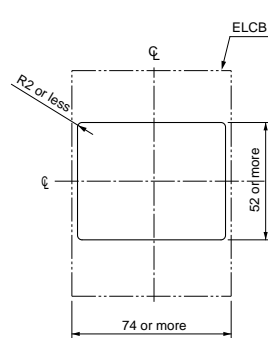

Terminal section

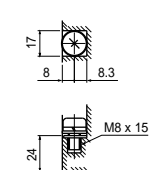



- Dimensions, mm
  - Front mounting, front connection
- EW125□U-3P**

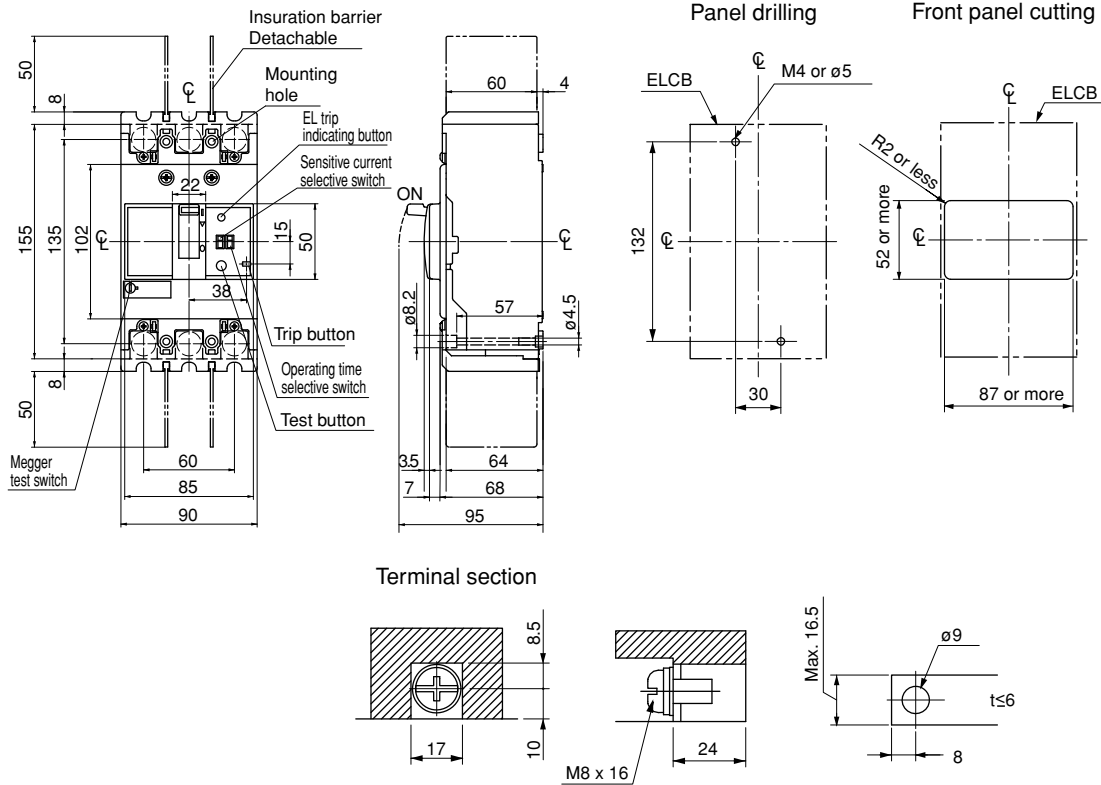

07

**EW250□U-3P**

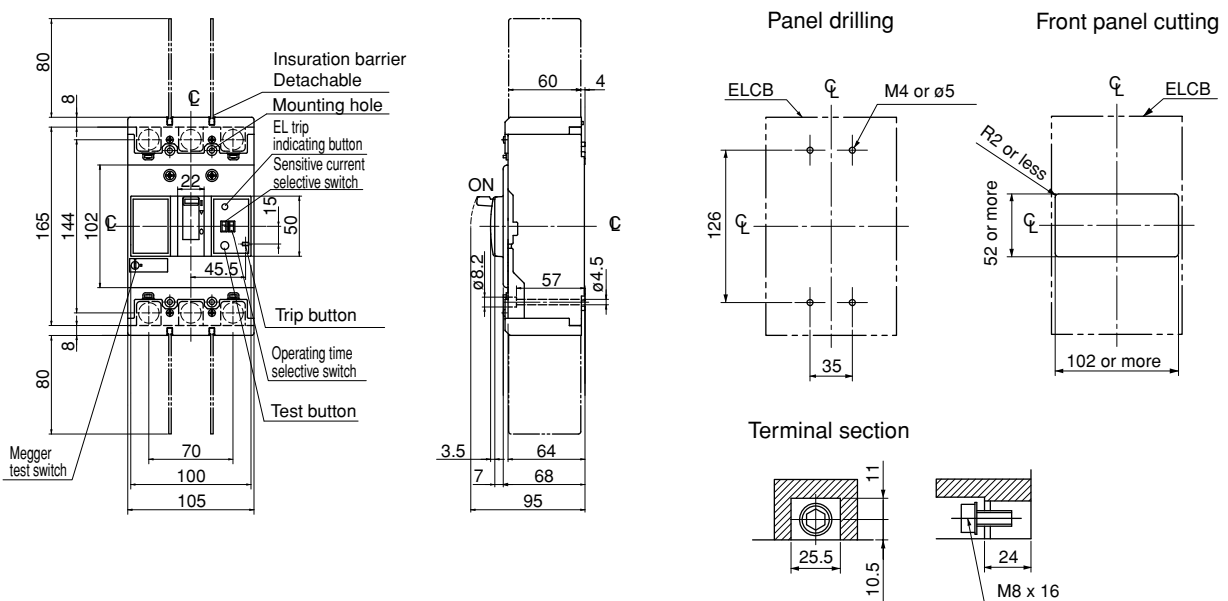



# Earth Leakage Circuit Breakers G-TWIN series Characteristic curves

## ■ Characteristic curves / Line protection EW32/50/63/100

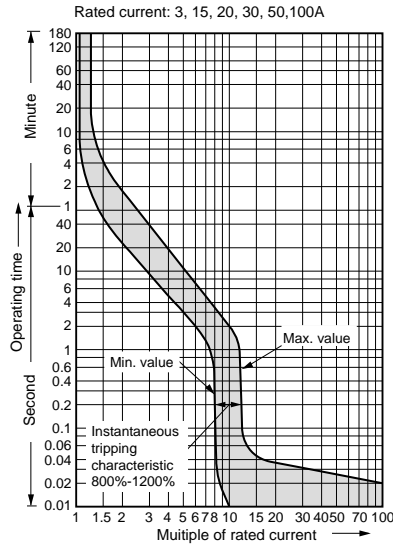
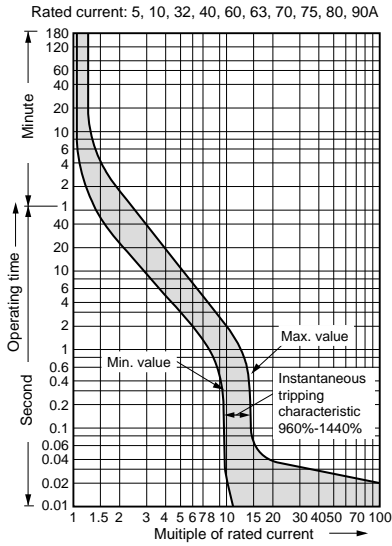

### Temperature correction curve

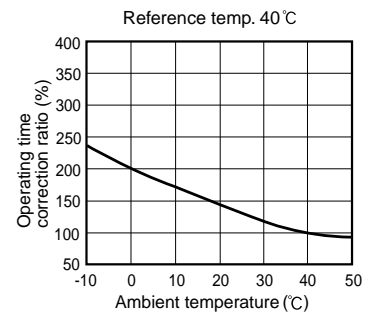

## Earth leakage tripping

### EW32/50/63/100A

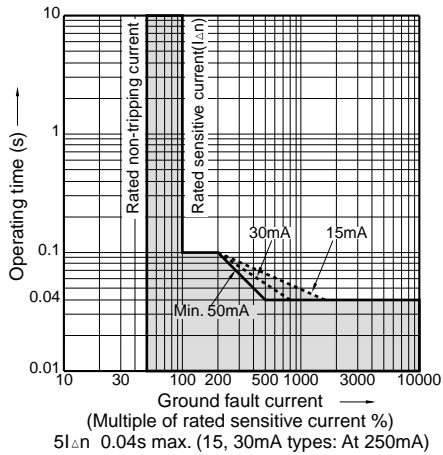

07

# Earth Leakage Circuit Breakers

## G-TWIN series

### Characteristic curves

#### ■ Characteristic curves / Line protection

##### EW125

###### • 15A

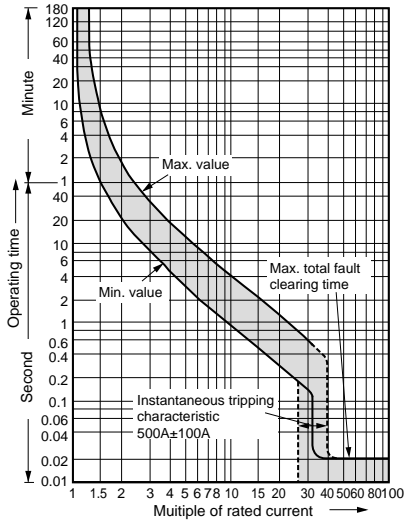

###### • 20A

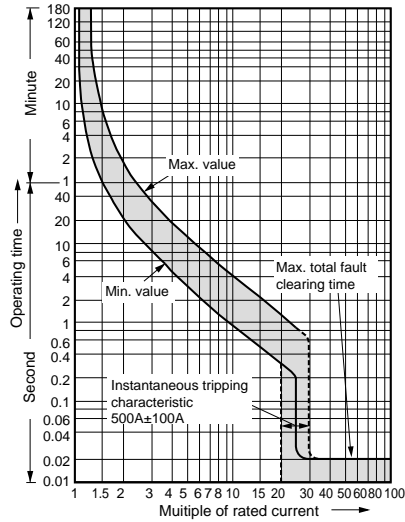

###### • 30A

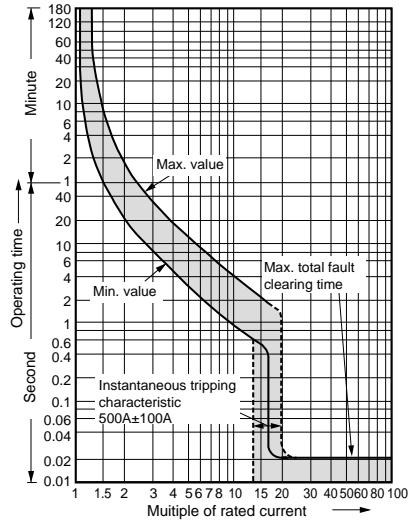

#### Temperature correction curve

##### • 15-30A

Reference temp. 40°C

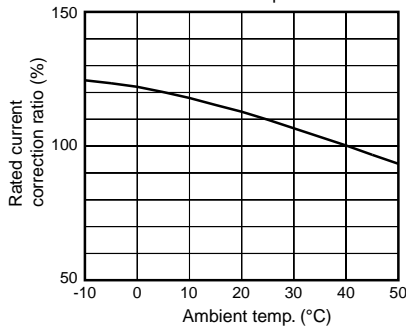

###### • 40A

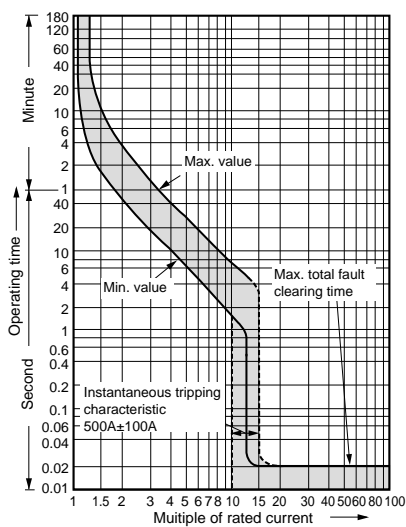

###### • 50-125A

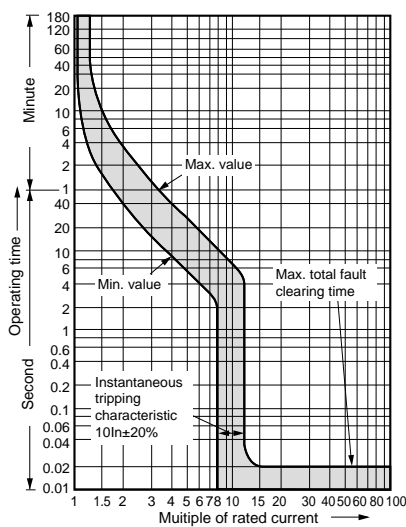

#### Temperature correction curve

##### • 40-125A

Reference temp. 40°C

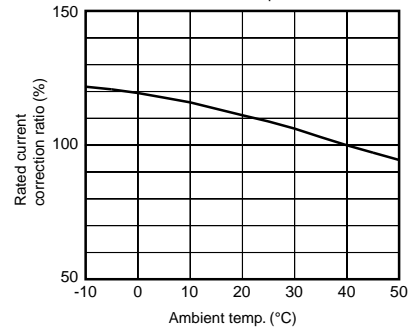

■ Characteristic curves / Line protection  
**EW160/250**

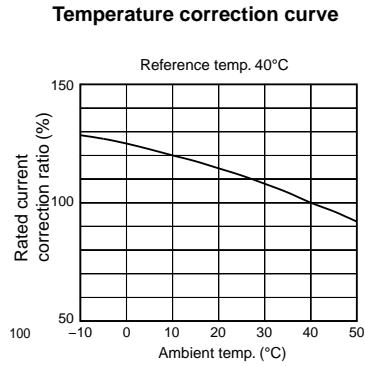
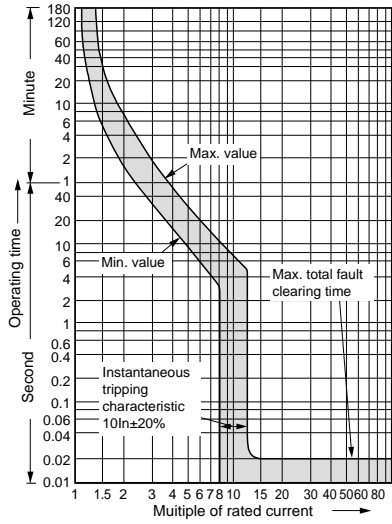

**EW400**

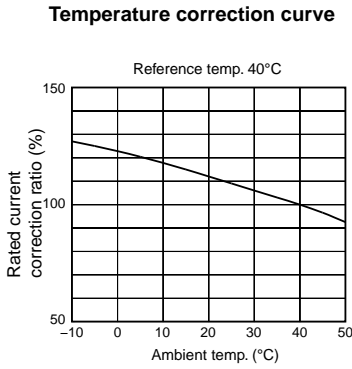
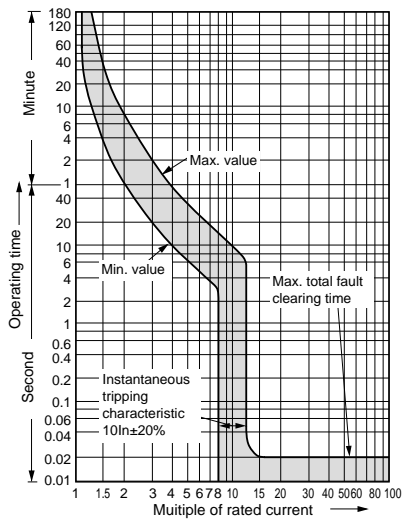

**EW630**

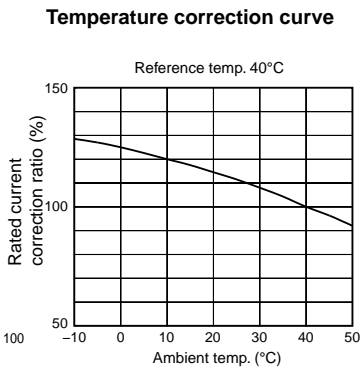
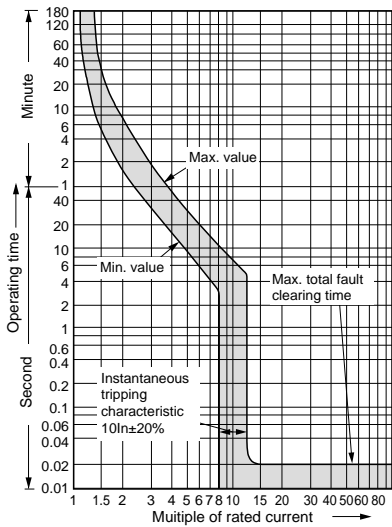

# Earth Leakage Circuit Breakers

## G-TWIN series

### Characteristic curves

#### ■ Characteristic curves / Line protection

#### EW800

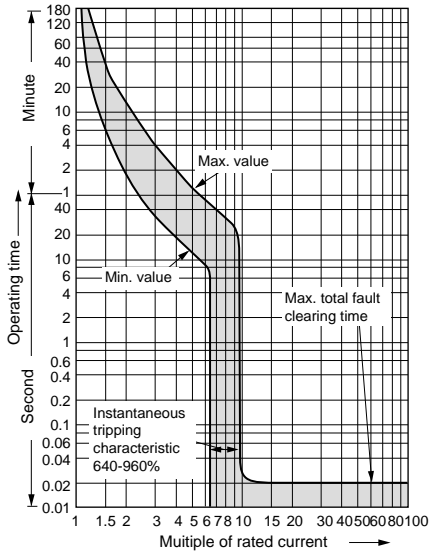

Temperature correction curve

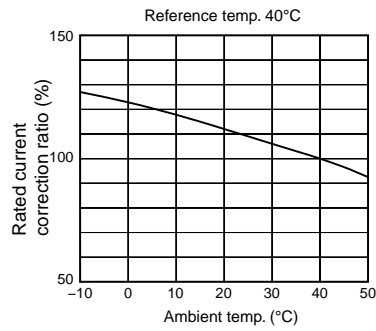

#### Earth leakage tripping

#### EW125/160/250/400/630/800

Instantaneous trip type

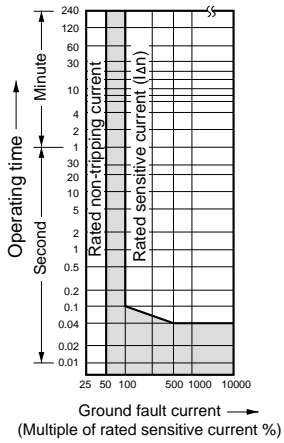

Time-delay trip type

Max. operating time: 0.4s    Max. operating time: 1s    Max. operating time: 2s

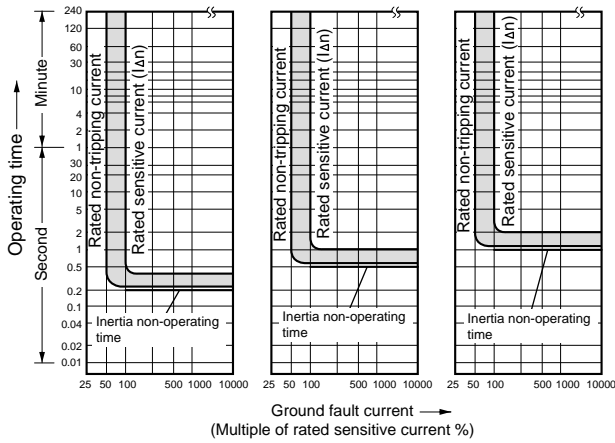

**■ Characteristic curves / Motor protection  
EW32/50/63/100**

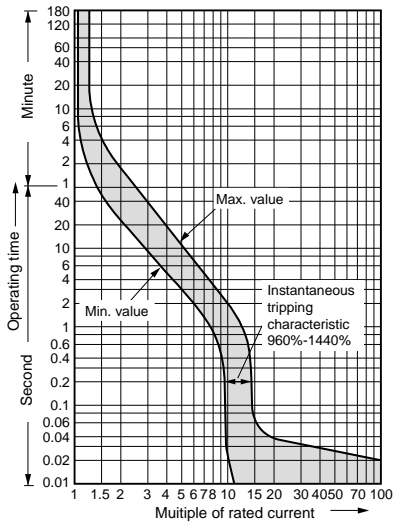

**Temperature correction curve**

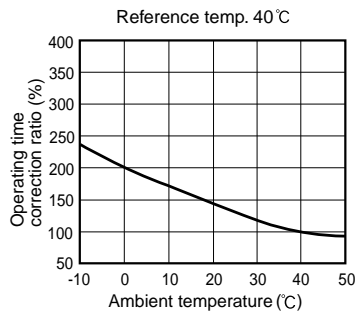

**EW125**

• 16A

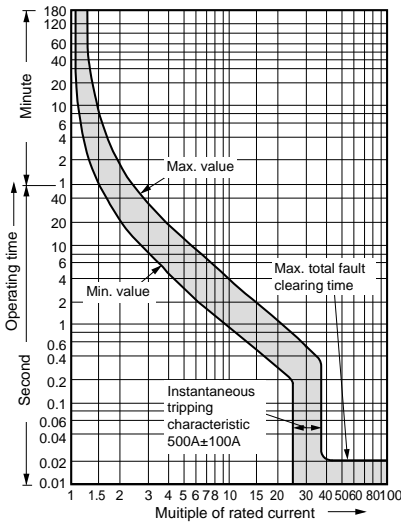

• 24A

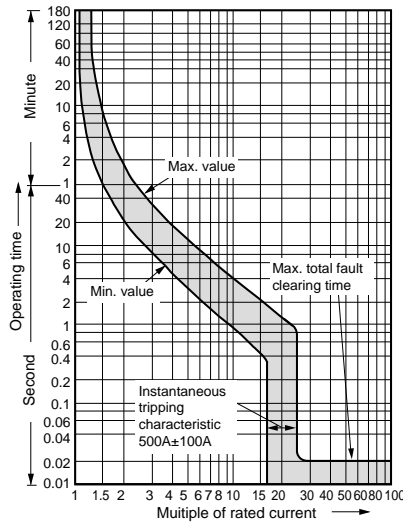

• 32A

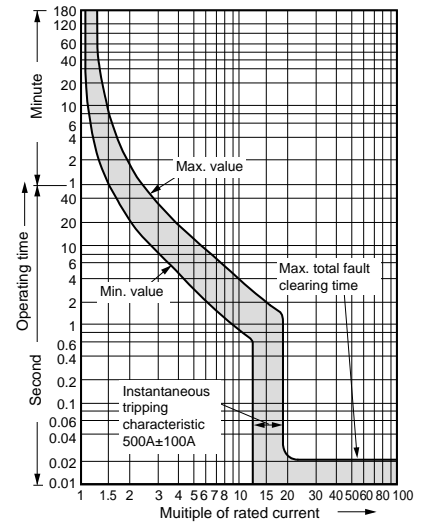

• 40-90A

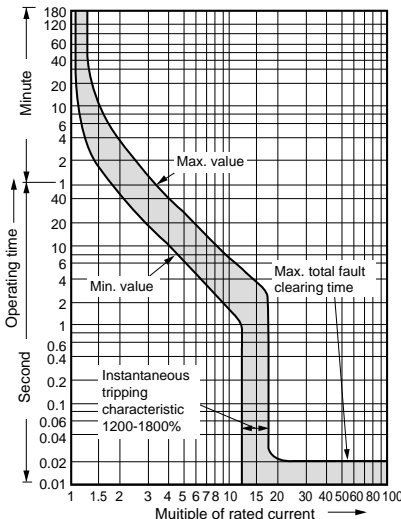

**Temperature correction curve**

• 15-32A

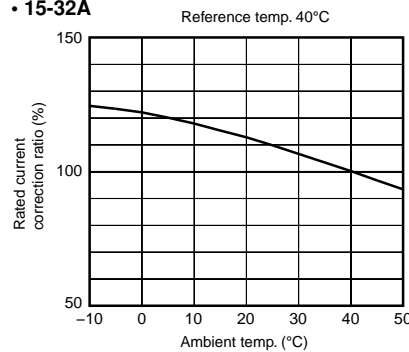

• 40-90A

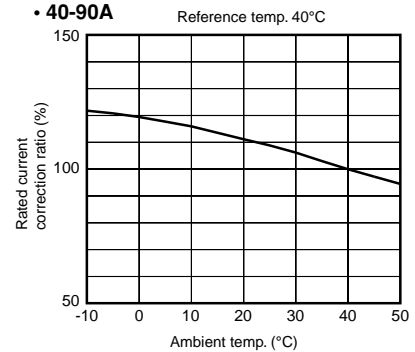

# Earth Leakage Circuit Breakers

## G-TWIN series

### Characteristic curves

#### ■ Characteristic curves / Motor protection

#### EW250

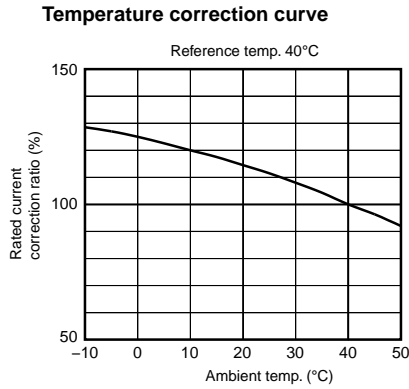
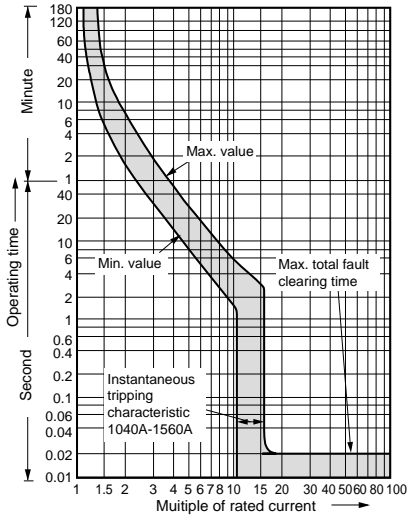

#### Earth leakage tripping

#### EW32/50/63

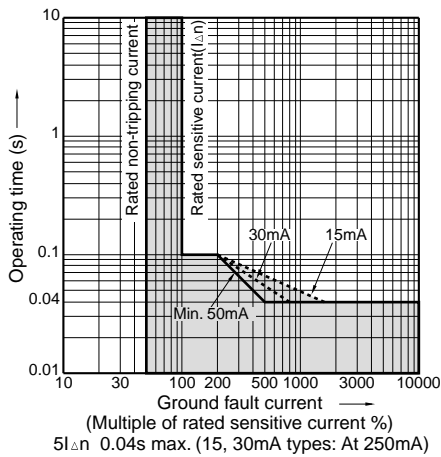

#### EW125/250

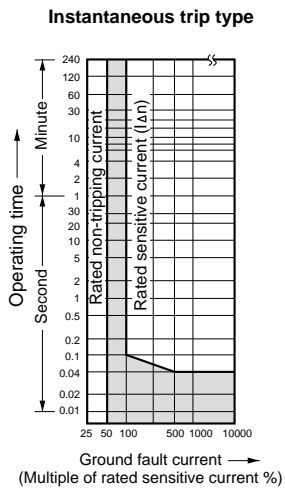

#### Time-delay trip type

Max. operating time: 0.4s    Max. operating time: 1s    Max. operating time: 2s

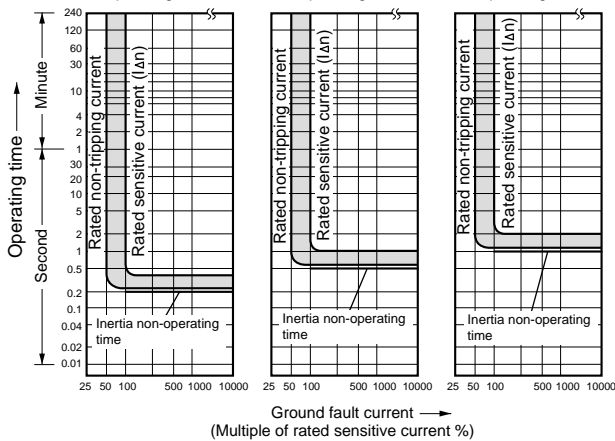



■ Variation of internal accessory  
 • 32 to 100AF

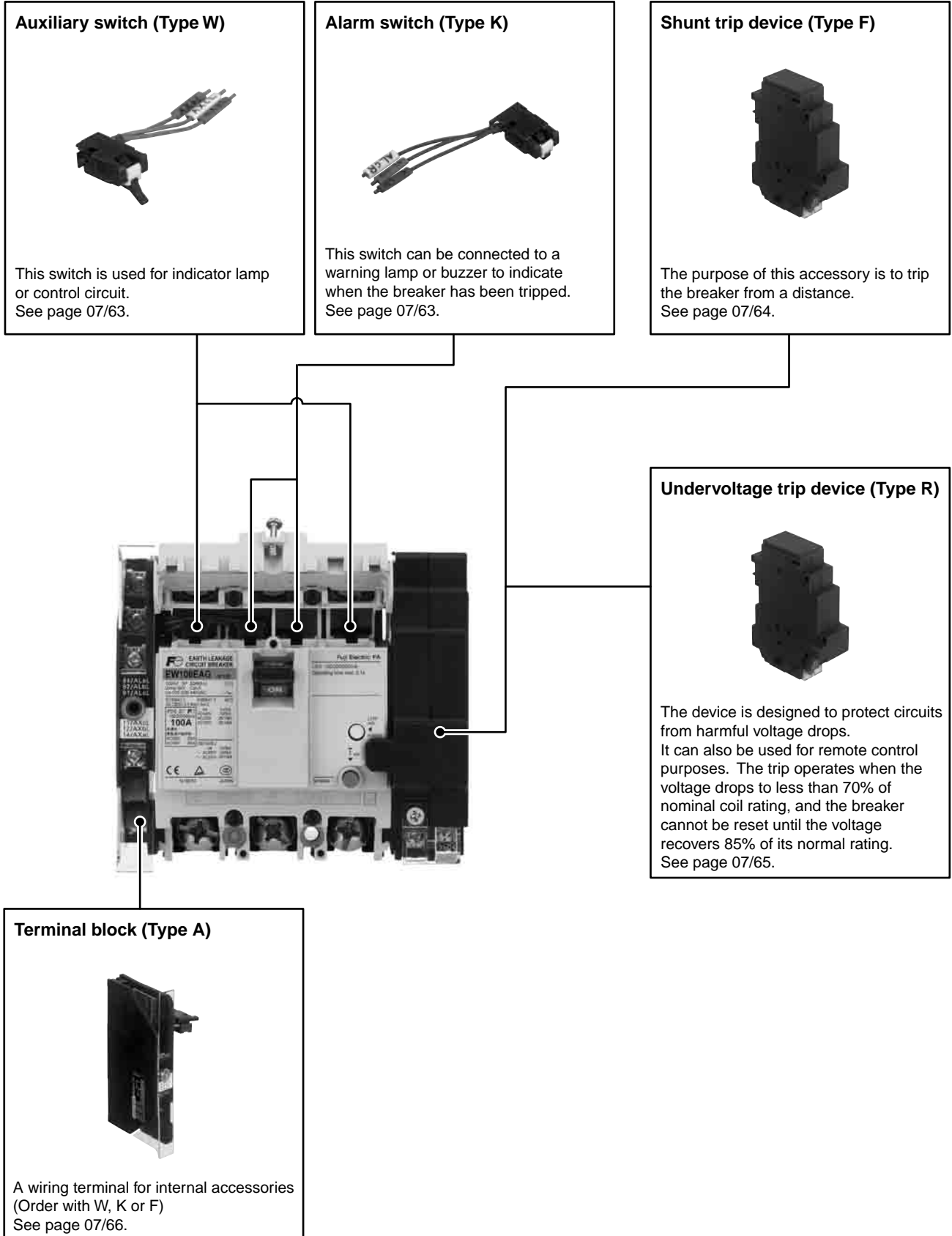

# Earth Leakage Circuit Breakers

## G-TWIN series

### Accessories

#### ■ Variation of internal accessory

• 125 to 250AF

#### Auxiliary switch (Type W)



This switch is used for indicator lamp or control circuit.  
See page 07/63.

#### Alarm switch (Type K)



This switch can be connected to a warning lamp or buzzer to indicate when the breaker has been tripped.  
See page 07/63.

#### Shunt trip device (Type F)



The purpose of this accessory is to trip the breaker from a distance.  
See page 07/64.

#### Undervoltage trip device (Type R)



The device is designed to protect circuits from harmful voltage drops. It can also be used for remote control purposes. The trip operates when the voltage drops to less than 70% of nominal coil rating, and the breaker cannot be reset until the voltage recovers 85% of its normal rating.  
See page 07/65.

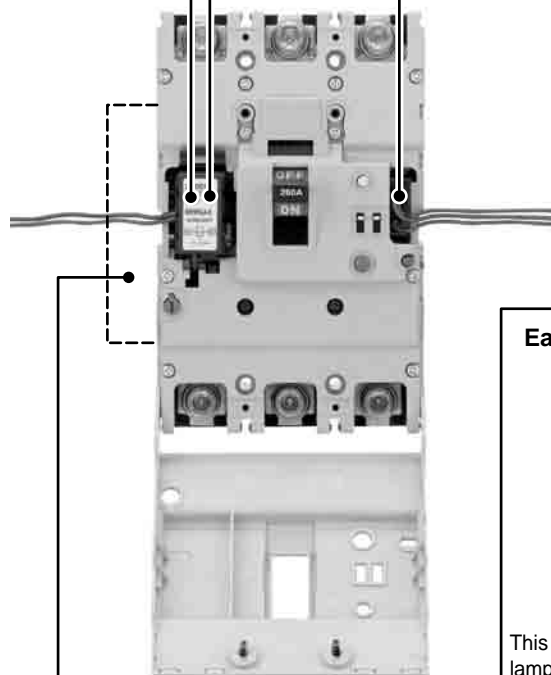

#### Earth alarm switch (Type L)



This switch can be connected to a warning lamp or buzzer to indicate when the breaker has been tripped by leakage current.  
See page 07/63.

#### Terminal block (Type A)



A wiring terminal for internal accessories (Factory-mounted)  
See page 07/66.

■ Variation of internal accessory  
 • 400 to 800AF

**Alarm switch (Type K)**



This switch can be connected to a warning lamp or buzzer to indicate when the breaker has been tripped. See page 07/63.

**Shunt trip device (Type F)**



The purpose of this accessory is to trip the breaker from a distance. See page 07/64.

**Terminal block (Type A)**

A wiring terminal for internal accessories (Factory-mounted)  
 See page 07/66.

**Undervoltage trip device (Type R)**



The device is designed to protect circuits from harmful voltage drops. It can also be used for remote control purposes. The trip operates when the voltage drops to less than 70% of nominal coil rating, and the breaker cannot be reset until the voltage recovers 85% of its normal rating. See page 07/65.

**Auxiliary switch (Type W)**



This switch is used for indicator lamp or control circuit. See page 07/63.

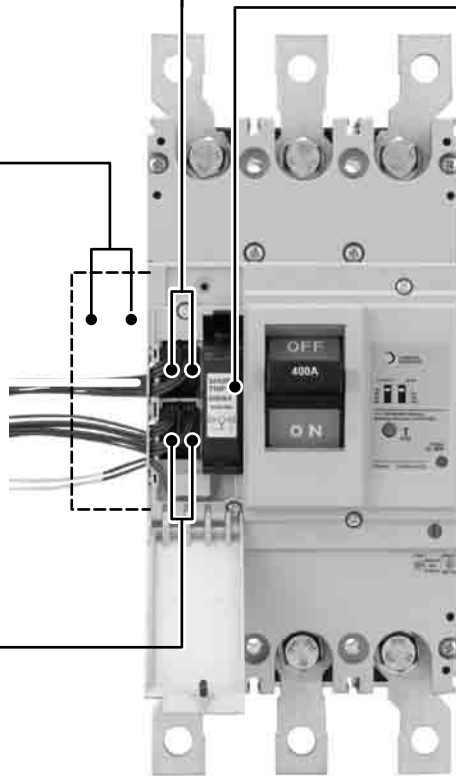

**Earth alarm switch (Type L)**

This switch can be connected to a warning lamp or buzzer to indicate when the breaker has been tripped by leakage current. See page 07/63. (Factory-mounted)

# Earth Leakage Circuit Breakers

## G-TWIN series

### Accessories

#### ■ Variation of external accessory

##### External operating handles

###### • N-type

See page 07/74.

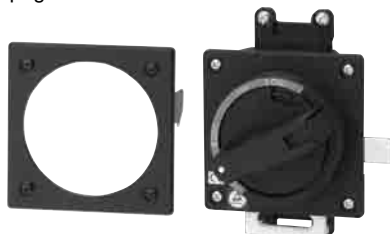

###### • V-type

See page 07/74.



###### • F-type

See page 07/74.

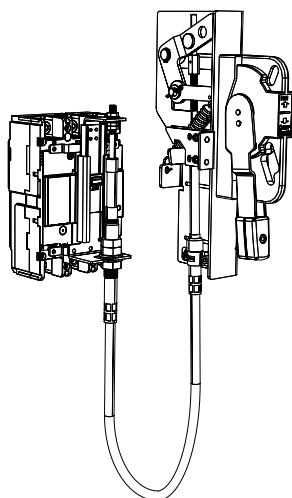

##### Terminal cover

###### Long type

See page 07/85.

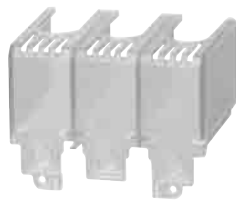

##### Interphase barrier

See page 07/86.



##### Terminal cover

###### Short type

See page 07/85.

##### Steel enclosures

See page 07/83.



##### Mechanical interlock device

See page 07/70.

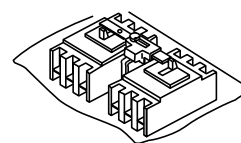

##### Motor-operating mechanism

See page 07/69.

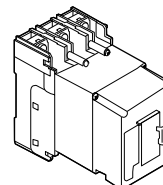

##### Handle locking cover (L1)

See page 07/87.

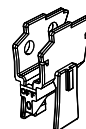

##### Padlocking device

See page 07/87.

###### • Cap type (Q1, QN)

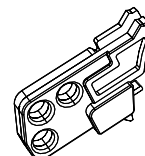

###### • Plate type (Q2)

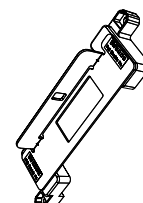

# Earth Leakage Circuit Breakers G-TWIN series Internal accessories

## Terminal blocks for auxiliary circuit

- It indicates the terminal No. of internal accessory. The connection method of internal accessory is lead-wire system and terminal block system.
- For the available configuration of internal accessory, see page 07/62.

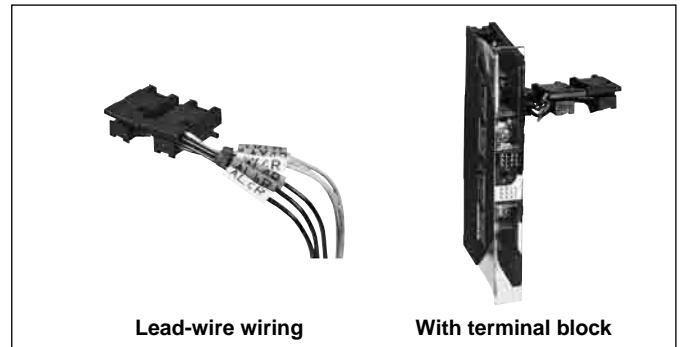

## Terminal number of internal accessory

Accessory		32 – 250AF		400 – 800AF
		Left side mounting	Right side mounting	Left side mounting
Auxiliary switch	SPDT: W (1)*			
	2PDT: V (2)*			
Alarm switch	SPDT: K (8)*			
	2PDT: J (9)*			
Shunt trip device : F	With 1NO contact to prevent coil burn-out			—
	Continuous rating	—		
Undervoltage trip device : R				
Earth alarm switch (125 to 800AF)				

Note: \* ( ) Code of Low level circuit

# Earth Leakage Circuit Breakers

## G-TWIN series

### Internal accessories

#### Available configurations

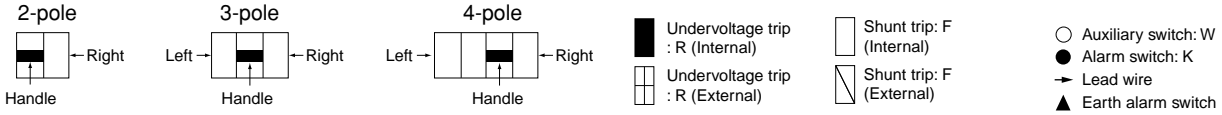

ECCB	EW32AAG-2P EW50AAG-2P	EW32□-3P EW50□-3P EW63□-3P EW100□-2P EW100□-3P	EW125 EW160 EW250	EW400 EW630 EW800	
Pole	2	2, 3	3	4	3, 4
Auxiliary switch SPDT: W (1)*					
Alarm switch SPDT: K (8)*					
Shunt trip: F					
Undervoltage trip: R					
W+K (1+8)					
Auxiliary switch 2PDT: V (2)					
Alarm switch 2PDT: J (9)					
V+K (2+8)					
W+J (1+9)					
V+J (2+9)					
W+F (1+F)					
W+R (1+R)					
K+F (8+F)					
K+R (8+R)					
W+K+F (1+8+F)					
W+K+R (1+8+R)					
V+F (2+F)					
V+R (2+R)					
J+F (9+F)					
J+R (9+R)					
V+K+F (2+8+F)					
V+K+R (2+8+R)					
W+J+F (1+9+F)					
W+J+R (1+9+R)					
V+J+F (2+9+F)					
V+J+R (2+9+R)					
L					

Notes: •The above table is applied to front mounting type, rear mounting type, flush mounting type, and plug-in mounting type.  
 • Terminal block is attached on the same side of the accessory.  
 • ( ) Code of low level circuit □:See page 07/2.

■ Operation of auxiliary switches(W) and alarm switches(K)

Accessory	Handle position	
	ON	OFF
Auxiliary switch	Trip	
	SPDT: <b>W</b> (1)	
	2PDT: <b>V</b> (2)	
Alarm switch	SPDT: <b>K</b> (8)	
	2PDT: <b>J</b> (9)	

Note: □ Ring mark indication  
( ) Code of low level circuit

■ Operation of earth alarm switch (L)

Accessory	Handle position	
	ON/OFF/Overcurrent trip	EL trip
Earth alarm switch L		

■ Ratings of auxiliary switches(W) and alarm switches(K)

• 32-100AF

	IEC60947-5-1			NECA C4505		Minimum load current
	Voltage (V)	Make/break current (A)		Voltage (V)	Make/break current (A)	
		AC 15	DC 13			Res. load
Standard type	125 AC	5	–	125 AC	5	5V DC 160mA 30V DC 30mA
	250 AC	5	–	250 AC	3	
	–	–	–	30 DC	4	
	125 DC	–	0.6	125 DC	0.4	
Low level circuit	250 DC	–	0.3	250 DC	0.2	5V DC 1mA
	–	–	–	30 DC	0.1	

• 125-800AF

	Rated thermal current (A)	Rated operational current (A)						Minimum load current
		AC			DC			
		Rated operational Voltage (V)	Res. load	Ind. load	Rated operational Voltage (V)	Res. load	Ind. load	
Standard type	5	24	5	5	24	4	3	5V DC 160mA 30V DC 30mA
		48	5	5	48	2.5	1	
		125	5	3	125	0.4	0.4	
		250	3	2	250	0.2	0.2	
Low level circuit	0.1	30	0.1	–	30	0.1	–	5V DC 1mA

# Earth Leakage Circuit Breakers

## G-TWIN series

### Internal accessories

#### ■ Rating of shunt trip (F)

ELCB type	Installation	AC		DC		Code	Time rating of coil	Opening time (ms)
		V	VA	V	W			
<b>EW32</b> <b>EW50</b> <b>EW63</b> <b>EW100</b>	External	100(50Hz)/ 100-110(60Hz)	16	–	–	FAC100V(50Hz)/ 100-110V(60Hz)	Continuous	7-13
		200(50Hz)/ 200-220(60Hz)	16	–	–	FAC200V(50Hz)/ 200-220V(60Hz)		
		400(50Hz)/ 400-440(60Hz)	22	–	–	FAC400V(50Hz)/ 400-440V(60Hz)		
		–	–	24	36	FDC24V		
		–	–	100-110	23	FDC100-110V		
<b>EW125</b> <b>EW160</b> <b>EW250</b>	Internal	24	50	24	50	FAC/DC24V	Continuous (With 1NO contact to prevent coil burn-out)	13-21
		48	50	48	50	FAC/DC48V		
		100-120	50	100-110	50	FAC100-120V/ DC100-110V		
		120-130	50	–	–	FAC120-130V		
		200-240	50	200-220	50	FAC200-240V/ DC200-220V		
		277	50	–	–	FAC277V		
		380-440	50	–	–	FAC380-440V		
		440-480	50	–	–	FAC440-480V		
500-550	50	–	–	FAC500-550V				
<b>EW400</b> <b>EW630</b> <b>EW800</b>	Internal	24-48	2	24-48	2	FAC/DC24-48V	Continuous	8-20
		100-240	3	100-220	3	FAC100-240V/ DC100-220V		
		277	3	–	–	FAC277V		
		380-550	4	–	–	FAC380-550V		

Note: The operating tripping voltage range for shunt trip devices is 70% to 110% of the rated operating voltage.



■ Rating of undervoltage trip (R)

ELCB type	Installation	AC		DC		Code
		V	VA	V	W	
<b>EW32</b> *2 <b>EW50</b> *2 <b>EW63</b> *2 <b>EW100</b> *2	External	100 (50Hz)/ 100-110(60Hz)	2.8	–	–	RAC100V(50Hz)/ 100-110V(60Hz)
		200 (50Hz)/ 200-220 (60Hz)	3.4	–	–	RAC200V(50Hz)/ 200-220V(60Hz)
		400 (50Hz)/ 400-440 (60Hz)	4.4	–	–	RAC400V(50Hz)/ 400-440V(60Hz)
		–	–	24	40	RDC24V
		–	–	100-110	–	RDC100-110V
<b>EW125</b> *1 <b>EW160</b> *1 <b>EW250</b> *1	Internal	–	–	24	5	RDC24V
		–	–	48	5	RDC48V
		–	–	100-110	5	RDC100-110V
		–	–	125	5	RDC125V
		100-110	5	–	–	RAC100-110V
		110-130	5	–	–	RAC110V-130V
		200-240	5	–	–	RAC200-240V
		277	5	–	–	RAC277V
		380-415	5	–	–	RAC380-415V
		440-480	5	–	–	RAC440V-480V
<b>EW400</b> *2 <b>EW630</b> *2 <b>EW800</b> *2	Internal	24	2	24	2	RAC/DC24V
		48	2	48	2	RAC/DC48V
		100-110	3	100-110	3	RAC/DC100-110V
		120-130	3	125	3	RAC120-130V/DC125V
		200-240	3	200-220	3	RAC200-240V/DC200-220V
		277	3	–	–	RAC277V
		380-480	4	–	–	RAC380-480V

Notes: • The operating voltages of undervoltage tripping devices are as follows:

Tripping voltage: 35% to 70% of rated voltage, closing voltage: 85% to 110% of rated voltage.

\*1 Reset-allowed type: When the breaker handle is in the OFF or RESET state, tripping does not occur even if the R coil is not energized. Turning ON with the R coil not energized causes normal tripping.

\*2 Reset-prohibited type: When the R coil is not energized, reset operation cannot reset the tripped breaker to the OFF state.



# Earth Leakage Circuit Breakers

## G-TWIN series

### Internal accessories

■ Type number

**Internal accessories (Sold separately)**

• 32, 50, 63, 100AF IEC/EN/GB/JIS conformed

Accessory	Type				Operating voltage					
	Lead wire system		Terminal block system							
	Left side	Right side	Left side	Right side						
Auxiliary switch	<b>BZ6WL10C</b>	<b>BZ6WR10C</b>	<b>BZ6WL10CA</b>	<b>BZ6WR10CA</b>	/					
Auxiliary switch (low level circuit)	<b>BZ6WDL10C</b>	<b>BZ6WDR10C</b>	<b>BZ6WDL10CA</b>	<b>BZ6WDR10CA</b>						
Alarm switch	<b>BZ6KL10C</b>	<b>BZ6KR10C</b>	<b>BZ6KL10CA</b>	<b>BZ6KR10CA</b>						
Alarm switch (low level circuit)	<b>BZ6KDL10C</b>	<b>BZ6KDR10C</b>	<b>BZ6KDL10CA</b>	<b>BZ6KDR10CA</b>						
Auxiliary switch + Alarm switch	<b>BZ6WKL10C</b>	<b>BZ6WKR10C</b>	<b>BZ6WKL10CA</b>	<b>BZ6WKR10CA</b>						
Auxiliary switch + Alarm switch (low level circuit)	<b>BZ6WDKDL10C</b>	<b>BZ6WDKDR10C</b>	<b>BZ6WDKDL10CA</b>	<b>BZ6WDKDR10CA</b>						
Shunt trip device	/					<b>BZ6F210C</b>	100V AC 50Hz/100-110V AC 60Hz			
					<b>BZ6F110C</b>	110V AC 50Hz/100-127V AC 60Hz				
					<b>BZ6F710C</b>	200V AC 50Hz/200-220V AC 60Hz				
					<b>BZ6F410C</b>	220V AC 50Hz/220-240V AC 60Hz				
					<b>BZ6F510C</b>	230V AC 50Hz/230-240V AC 60Hz				
					<b>BZ6FB10C</b>	240V AC 50Hz				
					<b>BZ6F010C</b>	380V AC 50Hz 380-415V AC 60Hz				
					<b>BZ6F810C</b>	400V AC 50Hz 400-440V AC 60Hz				
Undervoltage trip device					/				<b>BZ6R210C</b>	100V AC 50Hz/100-110V AC 60Hz
									<b>BZ6R110C</b>	110V AC 50Hz/110-127V AC 60Hz
	<b>BZ6RW10C</b>	200V AC 50Hz/200-220V AC 60Hz								
	<b>BZ6R410C</b>	220V AC 50Hz/220-240V AC 60Hz								
	<b>BZ6R510C</b>	230V AC 50Hz/230-240V AC 60Hz								
	<b>BZ6R810C</b>	240V AC 50Hz								
	<b>BZ6R010C</b>	380V AC 50Hz 380-415V AC 60Hz								
	<b>BZ6R910C</b>	400V AC 50Hz 400-440V AC 60Hz								
	<b>BZ6RF10C</b>	24V DC								
	<b>BZ6RT10C</b>	100-110V DC								

• 32, 50, 63, 100AF IEC/EN/GB/JIS/UL/CSA conformed

Accessory	Type				Operating voltage
	Lead wire system		Terminal block system		
	Left side	Right side	Left side	Right side	
Auxiliary switch	<b>BZ6WL10CU</b>	<b>BZ6WR10CU</b>	<b>BZ6WL10CAU</b>	<b>BZ6WR10CAU</b>	/
Auxiliary switch (low level circuit)	<b>BZ6WDL10CU</b>	<b>BZ6WDR10CU</b>	<b>BZ6WDL10CAU</b>	<b>BZ6WDR10CAU</b>	
Alarm switch	<b>BZ6KL10CU</b>	<b>BZ6KR10CU</b>	<b>BZ6KL10CAU</b>	<b>BZ6KR10CAU</b>	
Alarm switch (low level circuit)	<b>BZ6KDL10CU</b>	<b>BZ6KDR10CU</b>	<b>BZ6KDL10CAU</b>	<b>BZ6KDR10CAU</b>	
Auxiliary switch + Alarm switch	<b>BZ6WKL10CU</b>	<b>BZ6WKR10CU</b>	<b>BZ6WKL10CAU</b>	<b>BZ6WKR10CAU</b>	
Auxiliary switch + Alarm switch (low level circuit)	<b>BZ6WDKDL10CU</b>	<b>BZ6WDKDR10CU</b>	<b>BZ6WDKDL10CAU</b>	<b>BZ6WDKDR10CAU</b>	
Shunt trip device	-	-	-	<b>BZ6F210CAU</b>	
	-	-	-	<b>BZ6F710CAU</b>	200V AC 50Hz/200-220V AC 60Hz
	-	-	-	<b>BZ6F810CAU</b>	400V AC 50Hz/400-440V AC 60Hz
Undervoltage trip device	-	-	-	<b>BZ6R210CAU</b>	100V AC 50Hz/100-110V AC 60Hz
	-	-	-	<b>BZ6RW10CAU</b>	110V AC 50Hz/110-127V AC 60Hz
	-	-	-	<b>BZ6R910CAU</b>	200V AC 50Hz/200-220V AC 60Hz

07

# Earth leakage Circuit Breakers

## G-TWIN series

### Internal accessories

#### • 125, 160, 250AF IEC/EN/GB/JIS/UL/CSA conformed

Accessory	Type				Operating voltage
	Lead wire system		Terminal block system		
	Left side	Right side	Left side	Right side *	
Auxiliary switch	BW9W1SG0	BW9W1SG0-R	BW9W1SG0-A	-	-
Auxiliary switch (low level circuit)	BW9W1DG0	BW9W1DG0-R	- *		
Alarm switch	BW9K1SG0	BW9K1SG0-R	BW9K1SG0-A		
Alarm switch (low level circuit)	BW9K1DG0	BW9K1DG0-R	- *		
Auxiliary switch + Alarm switch	BW9WKSG0	BW9WK1SG0-R	BW9WKSG0-A		
Auxiliary switch + Alarm switch (low level circuit)	BW9WKDG0	BW9WK1DG0-R	- *		
Earth alarm switch	-	BW9L1SGA	-		
Shunt trip device	BW9FRG0	BW9FRG0	BW9FRG0-A		24V AC/DC
	BW9FSG0	BW9FSG0	BW9FSG0-A		48V AC/DC
	BW9FAG0	BW9FAG0	BW9FAG0-A		100-120V AC/100-110V DC
	BW9F1G0	BW9F1G0	BW9F1G0-A		120-130V AC
	BW9FKG0	BW9FKG0	BW9FKG0-A		200-240V AC/200-220V DC
	BW9FBG0	BW9FBG0	BW9FBG0-A		277V AC
	BW9FPG0	BW9FPG0	BW9FPG0-A		380-440V AC
	BW9FHG0	BW9FHG0	BW9FHG0-A		440-480V AC
	BW9FJG0	BW9FJG0	BW9FJG0-A		500-550V AC
Undervoltage trip devices	BW9RGAR	-	BW9RGAR-A		24V DC
	BW9RGAS		BW9RGAS-A		48V DC
	BW9RGAL		BW9RGAL-A		100-110V DC
	BW9RGA5		BW9RGA5-A		125V DC
	BW9RGAA		BW9RGAA-A		100-110V AC
	BW9RGAT		BW9RGAT-A		110-130V AC
	BW9RGAK		BW9RGAK-A		200-240V AC
	BW9RGAB		BW9RGAB-A		277V AC
	BW9RGAP		BW9RGAP-A		380-415V AC
	BW9RGAH		BW9RGAH-A		440-480V AC

Note: \* Factory-mounted

#### • 400, 630, 800AF IEC/EN/GB/JIS/UL/CSA conformed

Accessory	Type		Operating voltage
	Lead wire system	Terminal block system *	
	Left side		
Auxiliary switch x 1	BW9W1SHA	-	-
Auxiliary switch x 2	BW9W2SHA		
Auxiliary switch (low level circuit) x 1	BW9W1DHA		
Auxiliary switch (low level circuit) x 2	BW9W2DHA		
Alarm switch x 1	BW9K1SHA		
Alarm switch x 2	BW9K2SHA		
Alarm switch (low level circuit) x 1	BW9K1DHA		
Alarm switch (low level circuit) x 2	BW9K2DHA		
Shunt trip device	BW9FHA-R		24-48V AC/DC
	BW9FHA-A		100-240V AC/100-220V DC
	BW9FHA-B		277V AC
	BW9FHA-P		380-550V AC
Undervoltage trip devices	BW9RHA-R		24V AC/DC
	BW9RHA-S		48V AC/DC
	BW9RHA-A		100-110 AC/DC
	BW9RHA-1		120-130V AC/125V DC
	BW9RHA-K		200-240V AC/200-220V DC
	BW9RHA-B		277V AC
	BW9RHA-P		380-480V AC

Note: \* Factory-mounted

**Motor-operated breakers**

■ **Description**

The breaker is fitted with a motor operating mechanism which enables ON, OFF and RESET operations to be carried out electronically by remote control.

The breakers do not conform to IEC and EN standard.



■ **Type and ratings**

ELCB type	Motor rating			Power source capacity	Mass (kg)
	Operating voltage	Operating time	Time rating		
EW32□-3P□M, EW50□-3P□M, EW63□-3P□M, EW100□-2P□M, EW100□-3P□M	100V DC	0.1s	15s per on-off operation	500VA	1.2
	100/110V AC 200/220V AC				1.3

■ **Ordering information**

Specify the following:

1. Type number
2. Motor operating voltage

■ **Dimensions, mm / Front mounting, front connection**

EW32□-3P, EW50□-3P, EW63□-3P, EW100□-2P, EW100□-3P

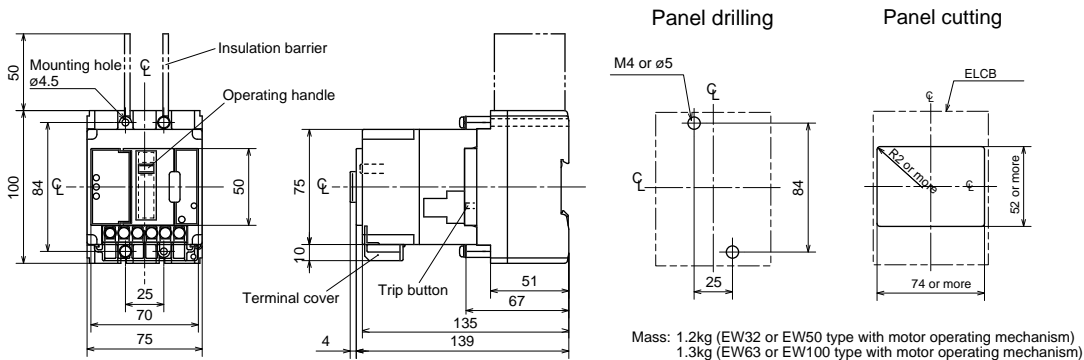

- Notes:
- Trip button operation can be carried out at right side of the breaker.
  - IEC 35mm wide mounting rail is not available.

■ **Wiring diagrams**

100/110V AC, 200/220V AC, 100V DC

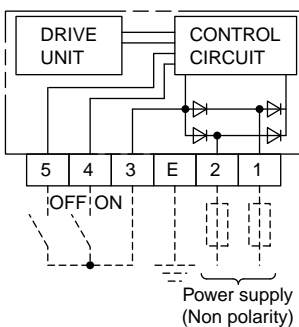

# Earth leakage Circuit Breakers

## G-TWIN series

### External accessories

#### Mechanical interlocking devices

##### ■ Description

These interlocking devices are mounted on the two separate breakers to prevent them from both being closed at the same time. A sliding mechanism that can be locked with a padlock is used. (The padlock is not included.)

They are designed for use when changing over power supplies.

These can be mounted to 3 types of breakers: front-mounting front-connection type, front-mounting rear-connection type (type X), and plug-in mounting type (type P). Interlock devices for flush mounting type breakers (type E, Y) are also available.

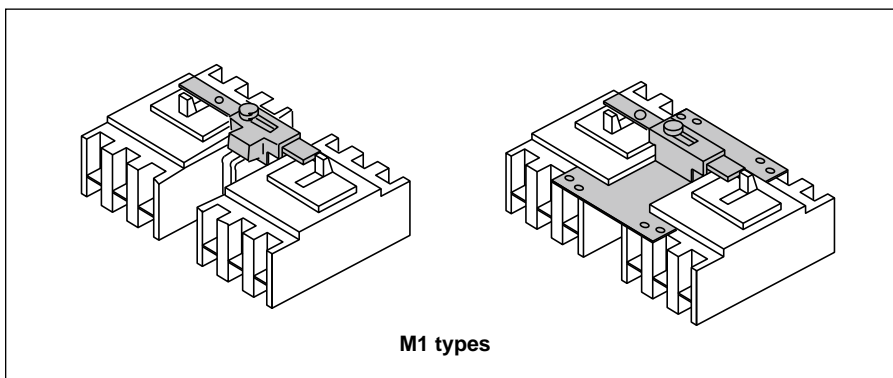

##### ■ Type and applicable breakers

Type	Breaker type
<b>BZ6M110C2</b>	EW32AAG-2P, EW50AAG-2P
<b>BZ6M110C3</b>	EW32□-3P, EW50□-3P, EW63□-3P, EW100□-2P, EW100□-3P
<b>BW9M1CA-3</b>	EW125□-3P
<b>BW9M1CA-4</b>	EW125□-4P
<b>BW9M1GA-3</b>	EW250□-3P
<b>BW9M1GA-4</b>	EW250□-4P
<b>BW9M1HA-3</b>	EW400□-3P
<b>BW9M1HA-4</b>	EW400□-4P
<b>BW9M1JA-3</b>	EW630□-3P, EW800□-3P

# Earth leakage Circuit Breakers G-TWIN series External accessories

■ Dimensions, mm  
• 32AF to 100AF

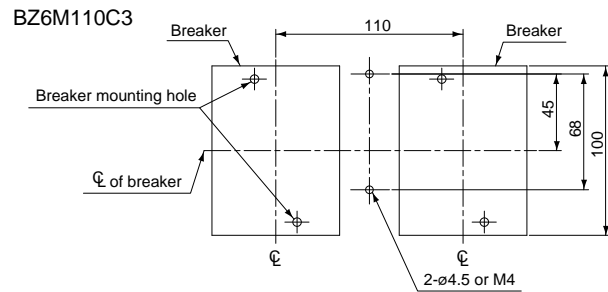
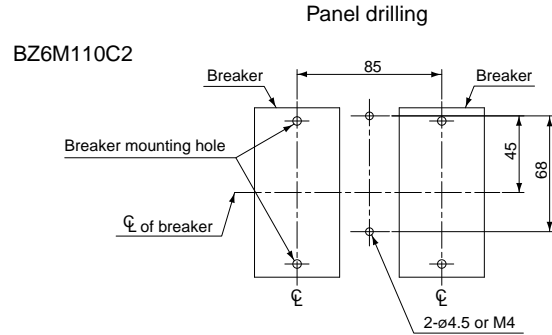
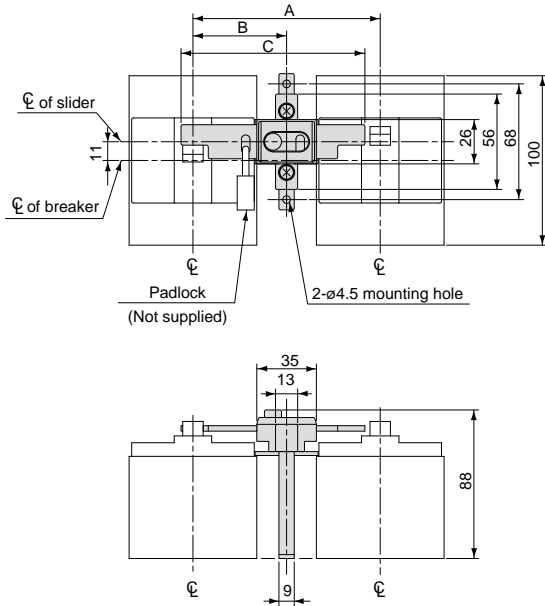

Type	Dimensions, mm			Mass (kg)
	A	B	C	
<b>BZ6M110C2</b>	85	42.5	83	0.11
<b>BZ6M110C3</b>	110	55	108	0.12

- Notes:
- BZ6M110C2 is not available for padlock.
  - Applicable padlock(ø3.5) dimensions, mm
  - External installation forms F and R are not applicable to the ELCB on the left of the diagram.

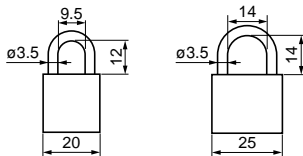

# Earth leakage Circuit Breakers

## G-TWIN series

### External accessories

■ Dimensions, mm  
• 125AF to 250AF

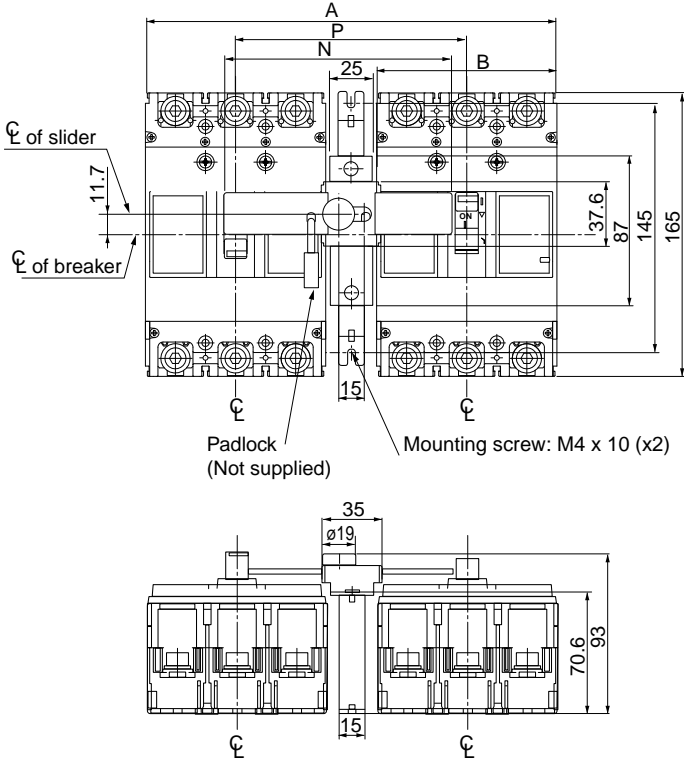

Panel drilling

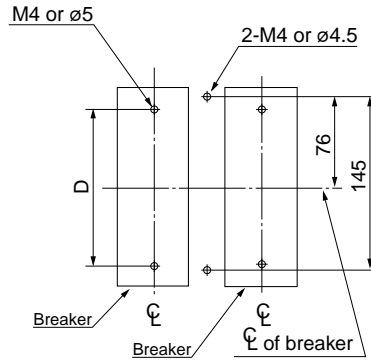

Fig.1

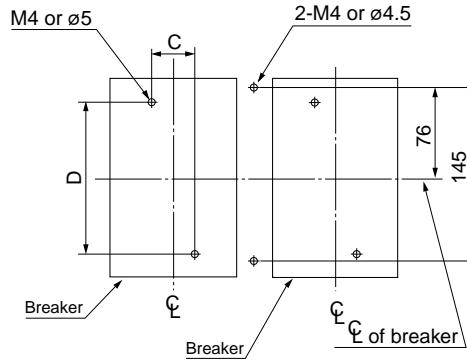

Fig.2

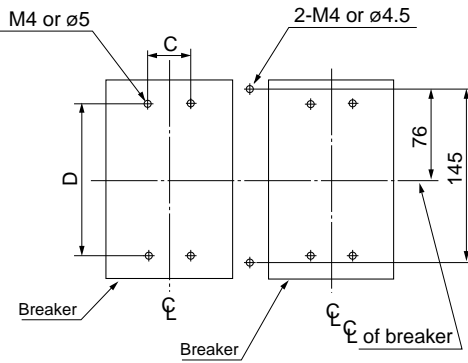

Fig.3

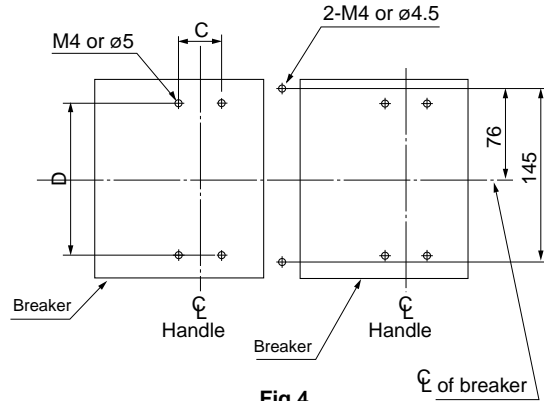
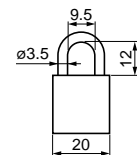

Fig.4

Type	Dimensions, mm						Panel Drilling	Mass(Kg)
	P	N	A	B	C	D		
BW9M1CA-2	90	88	150	60	-	132	Fig.1	
BW9M1CA-3	120	118	210	90	30	132	Fig.2	
BW9M1CA-4	150	148	270	102	30	132	Fig.4	
BW9M1GA-3	135	133	240	105	35	126	Fig.3	
BW9M1GA-4	170	168	310	140	35	126	Fig.4	

Notes: • The dimensions and Breaker mounting holes for back surface mounting are different from those given above. Inquire for details.  
• If a padlock is required, use a commercially available padlock with the dimensions shown in the diagram at the right.  
• External installation forms F and R are not applicable to the ELCB on the left of the diagram.





# Earth leakage Circuit Breakers G-TWIN series External accessories

■ Dimensions, mm  
• 400AF to 800AF

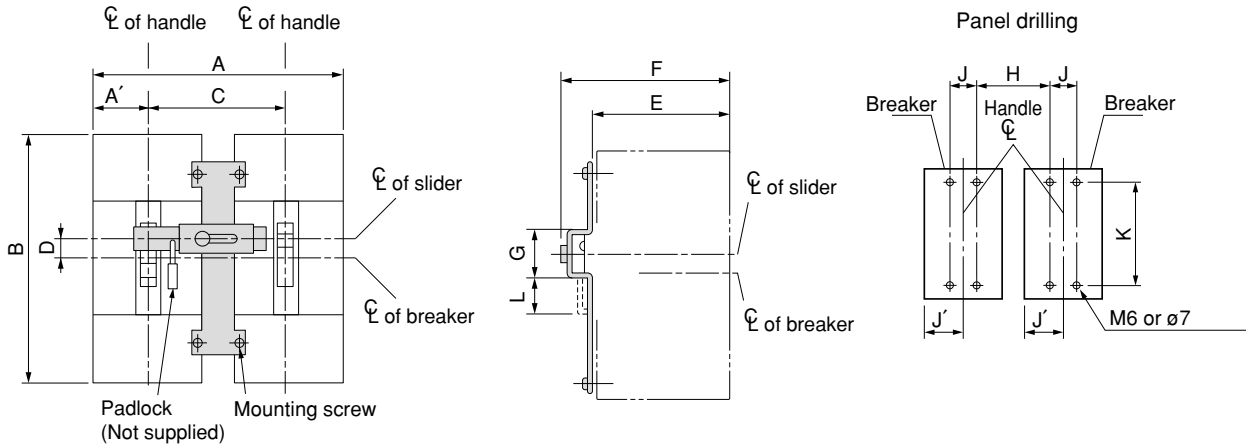

Type	Dimensions, mm											Mass(Kg)
	A (A')	B	C	D	E	F	G	H	J (J')	K	L	
<b>BW9M1HA-3</b>	355 (70)	257	215	20	94.5	132.5	54.5	171	44 (70)	215	38	
<b>BW9M1HA-4</b>	470 (140)	257	260	20	94.5	132.5	54.5	216	44 (140)	215	38	
<b>BW9M1JA-3</b>	500 (105)	275	290	20	94.5	132.5	54.5	220	70 (105)	243	38	

Notes: • The dimensions and Breaker mounting holes for back surface mounting are different from those given above. Inquire for details.  
• If a padlock is required, use a commercially available padlock with the dimensions shown in the diagram at the right.  
• External installation forms F and R are not applicable to the ELCB on the left of the diagram.

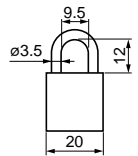

# Earth leakage Circuit Breakers

## G-TWIN series

### External accessories

#### External operating handles

##### ■ Description

Molded case circuit breaker handles are generally directly manual-operated but when mounted in motor control centers or on control panels they are sometimes required to be operated externally. To meet such applications FUJI offers the following three types of handles.

##### N type handle

This type has a knob handle directly attached to the breaker. It is easily fitted by cutting a hole in the panel, which is provided with a door interlock. They may be fitted to all breakers up to 800 ampere frame sizes. Conformed to EN60947-1 isolation function. Available for EN60204-1 power breaking device. Conformed to UL489 (File No.E93289)

##### V type handle

The V type handle may be fitted to breakers of up to 800AF. A separately sold extension shaft provides distance adjustment between the handle and breaker. Conformed to EN60947-1 isolation function. Available for EN60204-1 power breaking device. Conformed to UL489 (File No.E93289)

##### F type handle

The F type handle may be fitted to breakers of 125 to 400AF. It is a flange type handle, which is commonly used in the North American market. The drive section of the breaker and the external operating handle are connected with an optional cable. Positioning between the breaker and the external operating handle is not required. Conformed to UL489 (File No.E93289)



##### N type handles

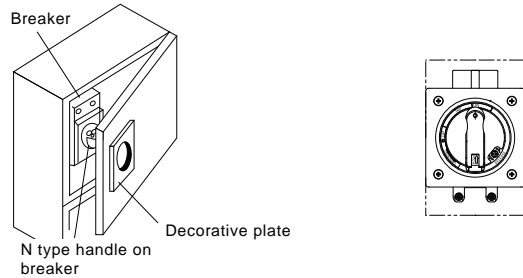

##### V type handles

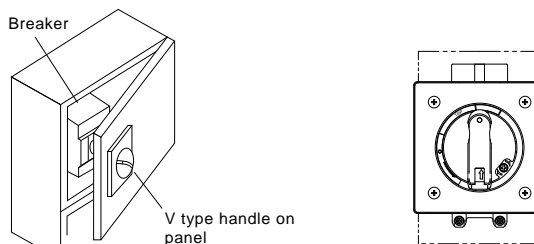

##### F type handles

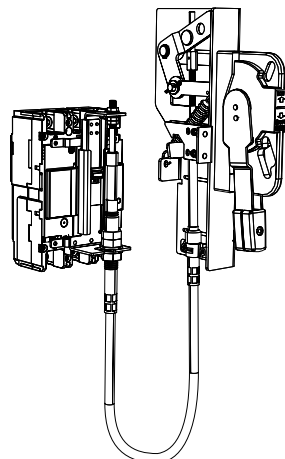

**N type handles**

ELCB	N type handle
EW32	<b>BZ6N10D</b>
EW50	
EW63	
EW100	
EW125	<b>BW9N0CA</b>
EW160	<b>BW9N0GA</b>
EW250	
EW400	<b>BW9N0HA</b>
EW630	<b>BW9N0JA</b>
EW800	

**V type handles**

ELCB	V type handle
EW32	<b>BZ6V10D</b>
EW50	
EW63	
EW100	
EW125	<b>BW9V0CA</b>
EW160	<b>BW9V0GA</b>
EW250	
EW400	<b>BW9V0HA</b>
EW630	<b>BW9V0JA</b>
EW800	

■ **Type number nomenclature**

• **N type handle**

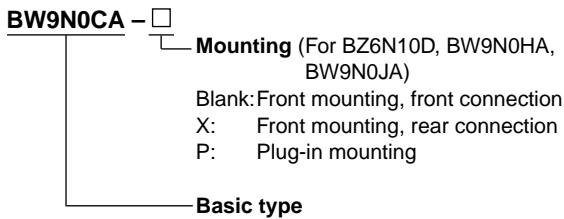

• **V type handle**

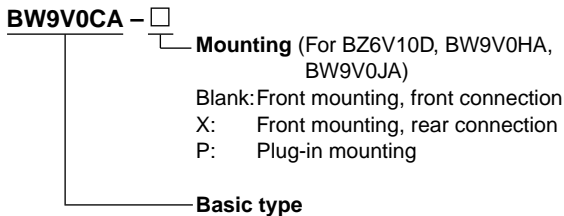

Note:  
 To order a V handle for front-mounting rear connection breakers, add "-X" to the type number; for plug-in mounting breakers, add "-P" to the type number.

**F type handles**

ELCB	F type handle
EW125	<b>BW9F0CA</b>
EW250	<b>BW9F0GA</b>
EW400	<b>BW9F0HA</b>

• **F type handle**

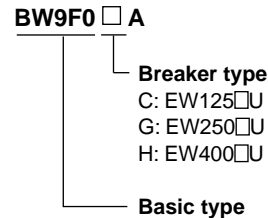

**Cable (For F type)**

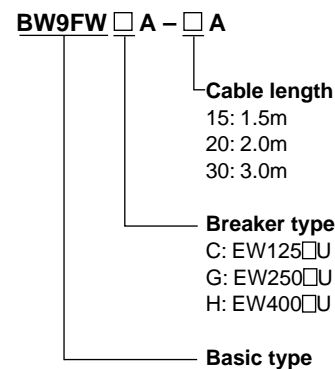

**Terminal cover (For F type)**

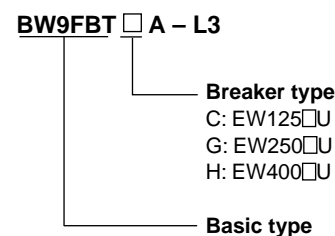

# Earth leakage Circuit Breakers

## G-TWIN series

### External accessories

#### ■ Dimensions, mm

#### N type handle

#### • BZ6N10D

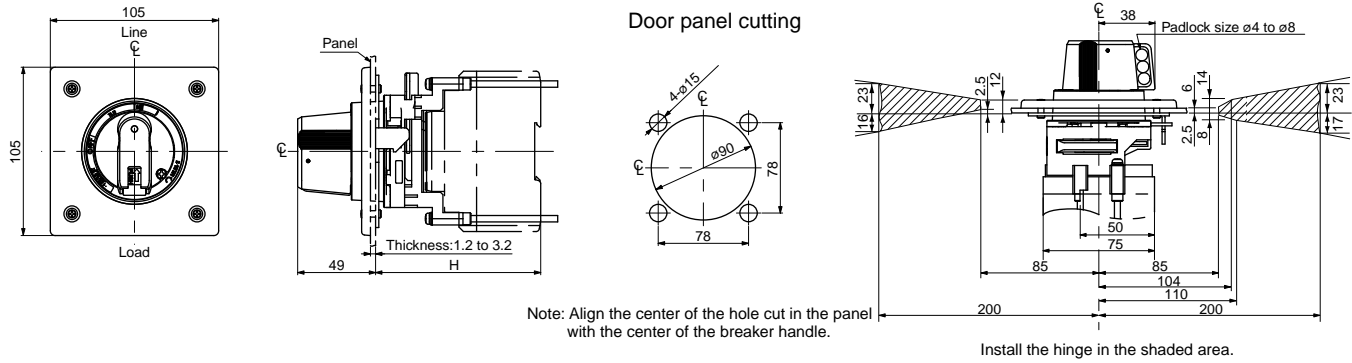

ELCB	Handle type	Dust proof packing	Mounting screw	H (mm)	Mass (kg)
EW32	<b>BZ6N10D</b>	Provided	M4 x 85	103±2	0.47
EW50	<b>BZ6N10D-X</b>	Provided	Contact FUJI.	111±2	
EW63	<b>BZ6N10D-P</b>			111±2	
EW100					

#### • BW9N0CA, BW9N0GA

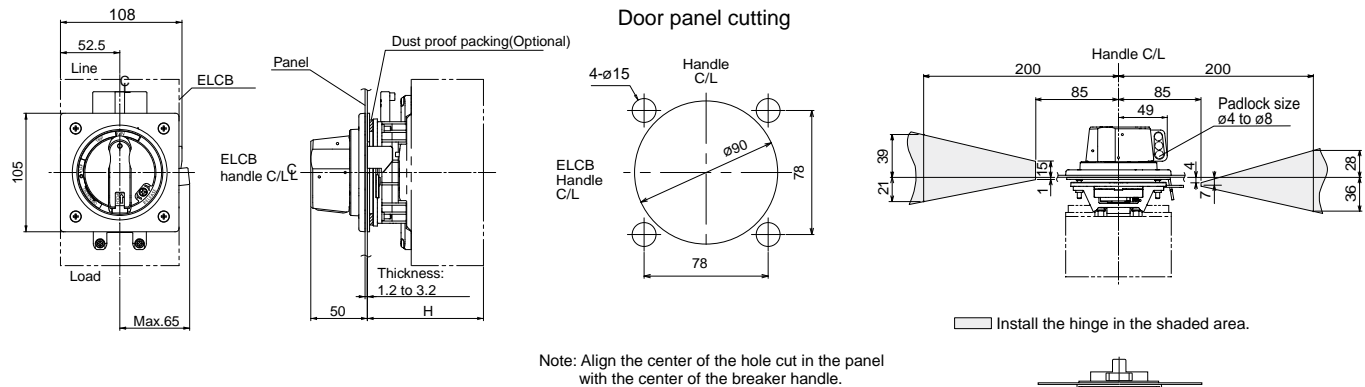

ELCB	Handle type	Dust proof packing	Mounting screw	H (mm)	Mass (kg)
EW125	<b>BW9N0CA</b>	BZ-NP-1C	M4 x 85	103±2	0.56
EW160	<b>BW9N0GA</b> *1	BZ-NP-1C	M4 x 85	103±2	0.56
EW250					

- Notes:
- The handle lock bars do not hold the entire door. Obtain a support bracket for the panel separately.
  - Remove the handle lock bar before opening the door. (Turn the handle in the open direction.) The lock bar will be damaged if the door is opened with force while the lock bar is engaged.
  - Engage the door interlock securely before turning ON the power.
  - \*1 The terminal cover will cover the mounting screws for the Breaker. When attaching the terminal cover, a portion of the terminal cover will need to be removed. Remove portion  in the following diagram.

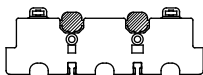

# Earth leakage Circuit Breakers G-TWIN series External accessories

## • BW9N0HA, BW9N0JA

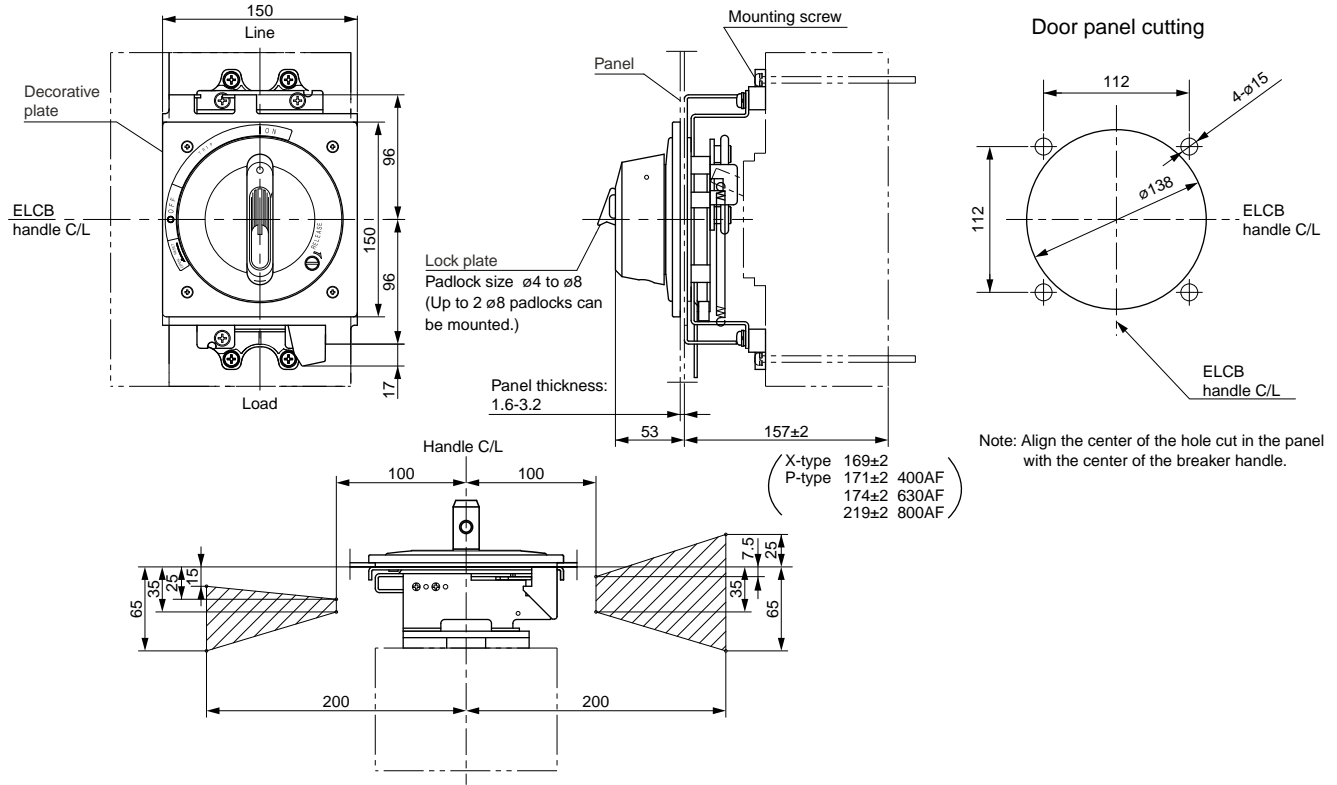

Note: Align the center of the hole cut in the panel with the center of the breaker handle.

Install the door hinge in the shaded area.

ELCB	Handle type	Dust proof packing	Mounting screw	Mass (kg)
EW400	<b>BW9N0HA</b> <b>BW9N0HA-X</b> <b>BW9N0HA-P</b>	BZ-NP-2	M6 x 110 M6 x 115 Contact FUJI.	1.9
EW630 EW800	<b>BW9N0JA</b> <b>BW9N0JA-X</b> <b>BW9N0JA-P</b>	BZ-NP-2	M6 x 110 M6 x 115 Contact FUJI.	1.9

- Notes:
- The handle lock bars do not hold the entire door. Obtain a support bracket for the panel separately.
  - Remove the handle lock bar before opening the door. (Turn the handle in the open direction.) The lock bar will be damaged if the door is opened with force while the lock bar is engaged.
  - Engage the door interlock securely before turning ON the power.
  - Not available for side mounting.

# Earth leakage Circuit Breakers

## G-TWIN series

### External accessories

#### ■ Dimensions, mm

#### V type handle

#### • BW6V10D

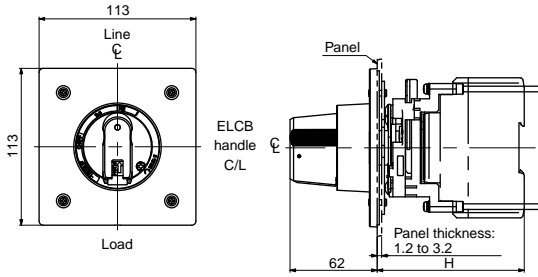

Optional shaft BZ6VS1D  
 $X = H - 105$

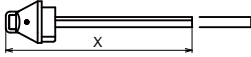

#### Door panel cutting

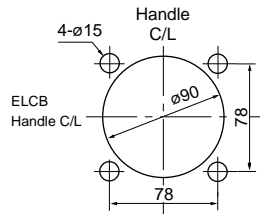

Note: Align the center of the hole cut in the panel with the center of the breaker handle.

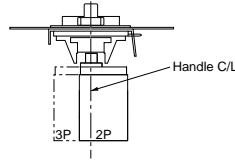

#### Door hinge installation area

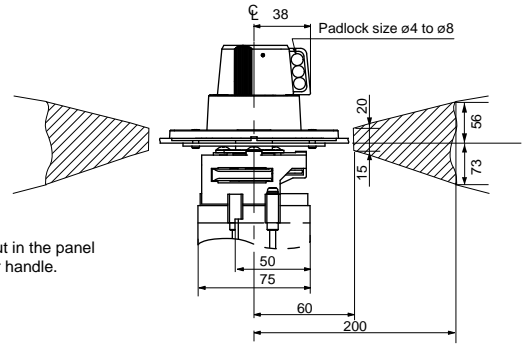

Install the door hinge in the shaded area.

#### • BW9V0CA, BW9V0GA

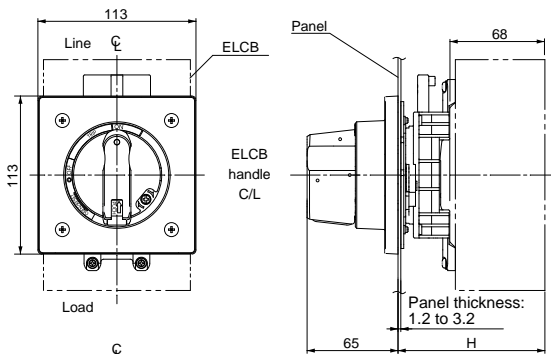

#### Door panel cutting

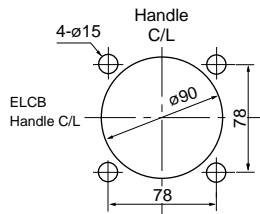

Note: Align the center of the hole cut in the panel with the center of the breaker handle.

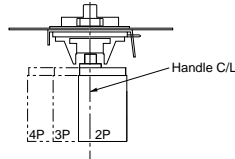

#### Door hinge installation area

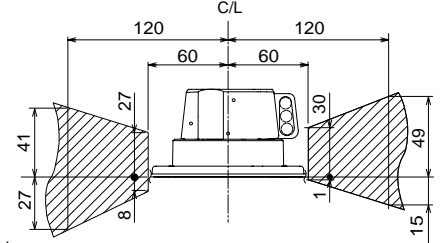

Install the door hinge in the shaded area.

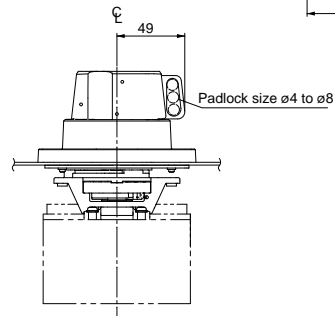

Optional shaft BW9VSG0  
 $X = H - 95$

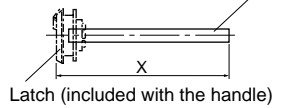

# Earth leakage Circuit Breakers

## G-TWIN series

### External accessories

ELCB	Handle type	Optional shaft	Standard type H	With the optional shaft (X=154)		Mounting screw	Mass (kg)
				H	Area in which the hinge with H can be installed		
EW32 EW50 EW63 EW100	<b>BZ6V10D</b>	<b>BZ6VS1D</b>	105±2	250±2	140 to 250	M4 x 80	0.64
	<b>BZ6V10D-X</b>		113±2	258±2	150 to 258	Contact FUJI.	0.64
	<b>BZ6V10D-P</b>		113±2	258±2	150 to 258	Contact FUJI.	0.64
EW125	<b>BW9V0CA</b>	<b>BW9VSG0</b>	105±2	250±2	140 to 250	M4 x 85	0.67
EW160 EW250	<b>BW9V0GA</b> *1		105±2	250±2	140 to 250	M4 x 85	0.67

- Notes:
- The handle lock bars do not hold the entire door. Obtain a support bracket for the panel separately.
  - Remove the handle lock bar before opening the door. (Turn the handle in the open direction.)  
The lock bar will be damaged if the door is opened with force while the lock bar is engaged.
  - Engage the door interlock securely before turning ON the power.
  - Not available for side mounting.
- \*1 The terminal cover will cover the mounting screws for the Breaker. When attaching the terminal cover, a portion of the terminal cover will need to be removed. Remove portion A in the following diagram.

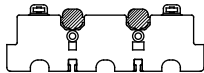

# Earth leakage Circuit Breakers

## G-TWIN series

### External accessories

• BW9V0HA, BW9V0JA

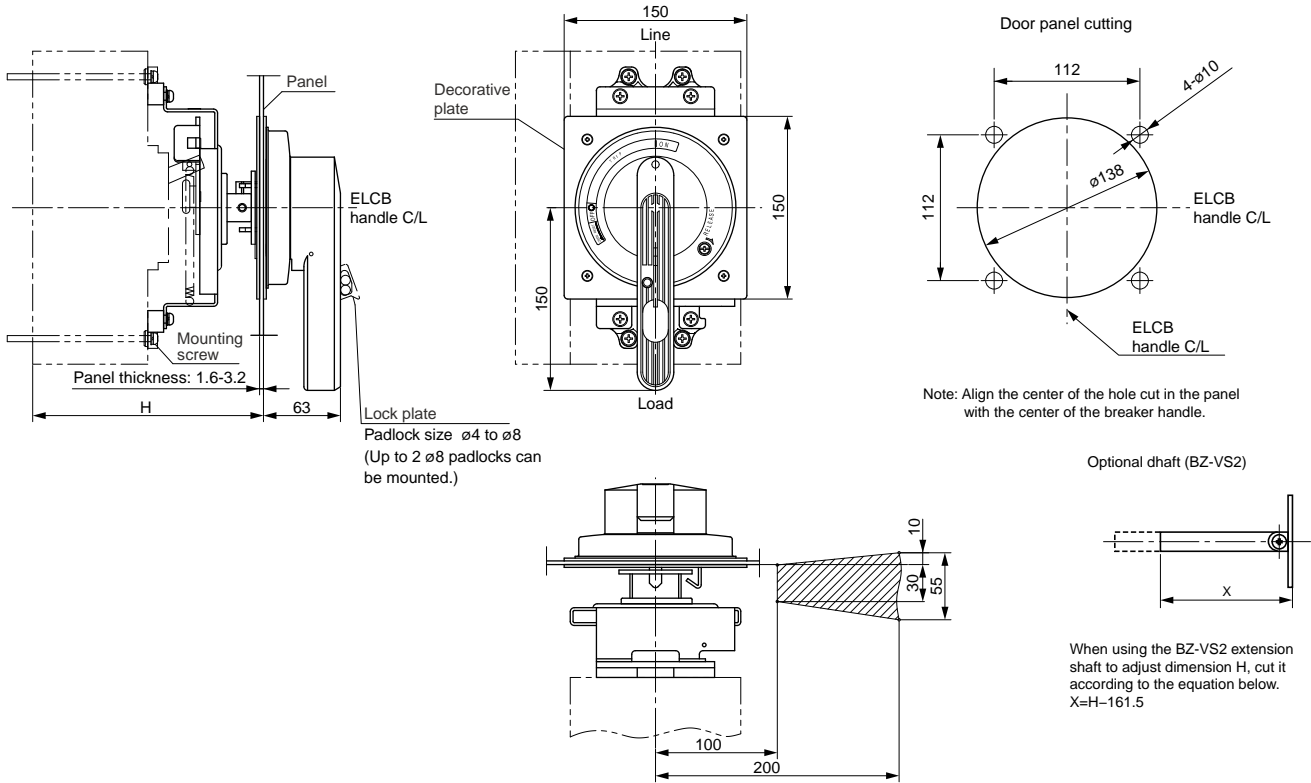

Install the door hinge in the shaded area.

ELCB	Handle type	Optional shaft	Standard type H	With the optional shaft (X=154)		Mass (kg)
				H	Area in which the hinge with H can be installed	
EW400	BW9V0HA	BZ-VS2	190±2	250±2	202 to 250	2.2
	BW9V0HA-X		202±2	262±2	214 to 262	
	BW9V0HA-P		204±2	264±2	216 to 264	
EW630	BW9V0JA	BZ-VS2	190±2	250±2	202 to 250	2.2
	BW9V0JA-X		202±2	262±2	214 to 262	
	BW9V0JA-P		207±2	267±2	219 to 269	
EW800	BW9V0JA	BZ-VS2	190±2	250±2	202 to 250	2.2
	BW9V0JA-X		202±2	262±2	214 to 262	
	BW9V0JA-P		252±2	312±2	264 to 312	

- Notes:
- The handle lock bars do not hold the entire door. Obtain a support bracket for the panel separately.
  - Remove the handle lock bar before opening the door. (Turn the handle in the open direction.)  
The lock bar will be damaged if the door is opened with force while the lock bar is engaged.
  - Engage the door interlock securely before turning ON the power.
  - Not available for side mounting.



# Earth leakage Circuit Breakers

## G-TWIN series

### External accessories

■ Dimensions, mm  
F type handle  
• BW9F0CA

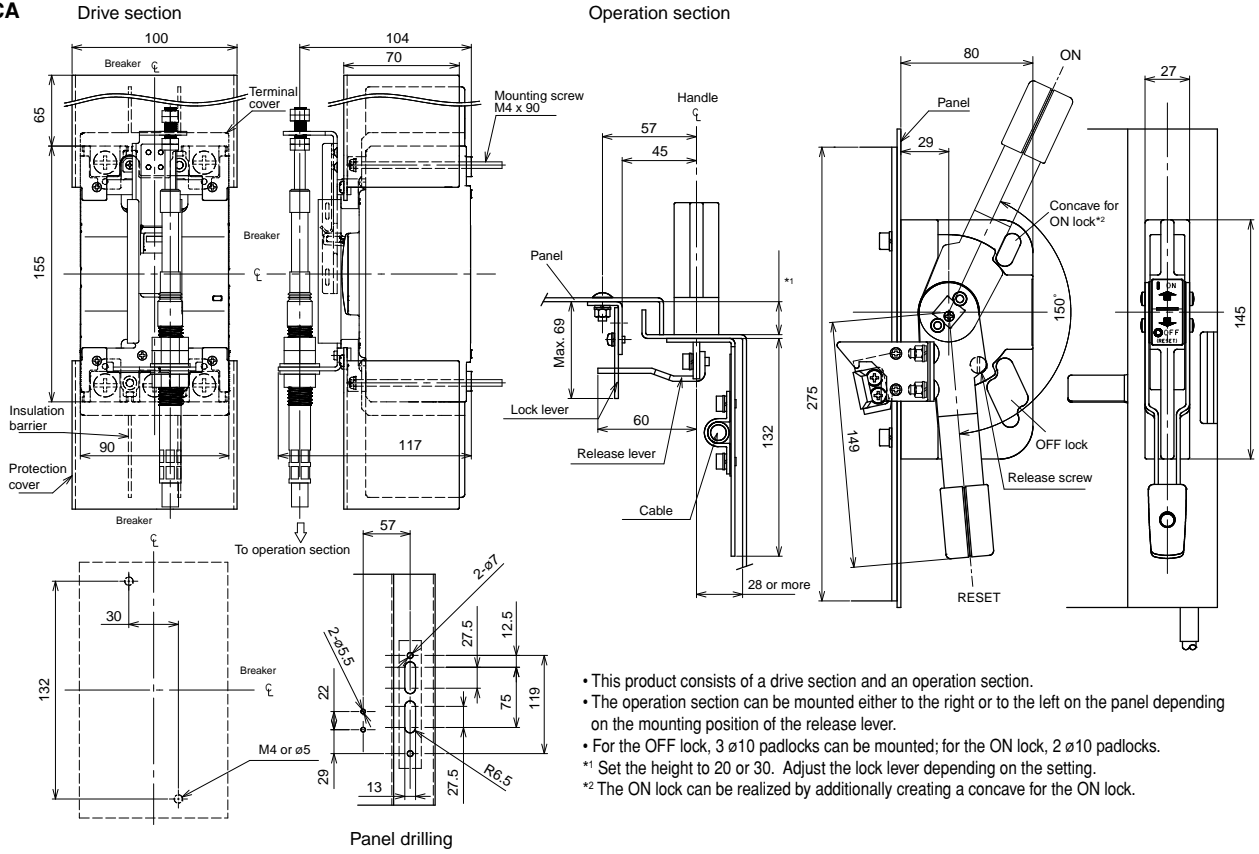

• BW9F0GA

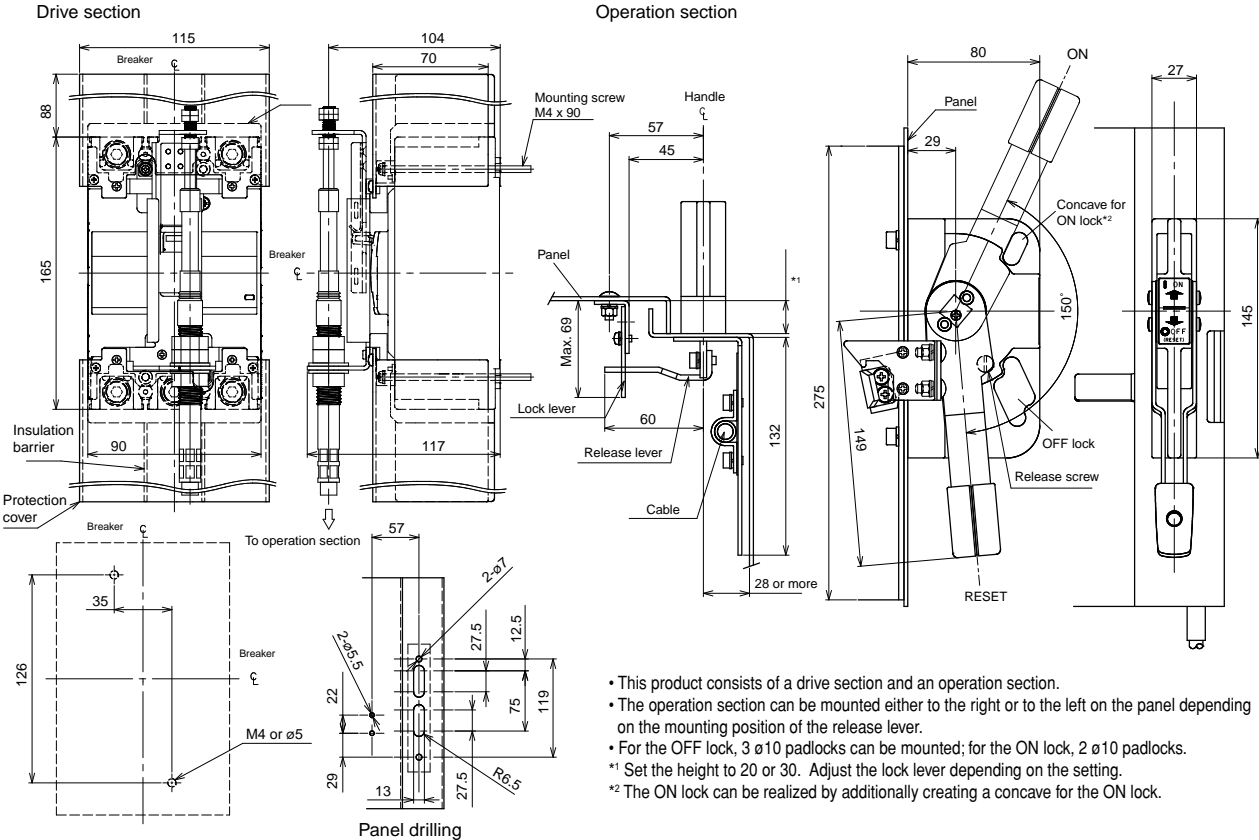

# Earth leakage Circuit Breakers

## G-TWIN series

### External accessories

#### • BW9F0HA

Drive section

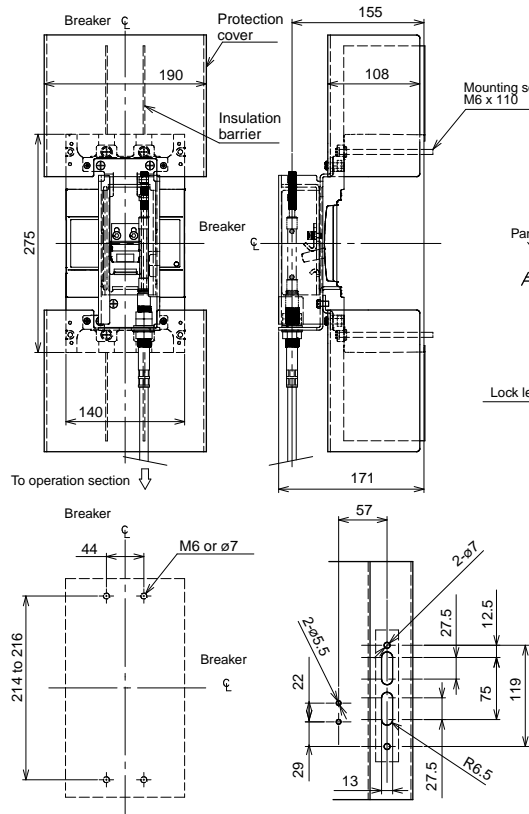

Panel drilling

Operation section

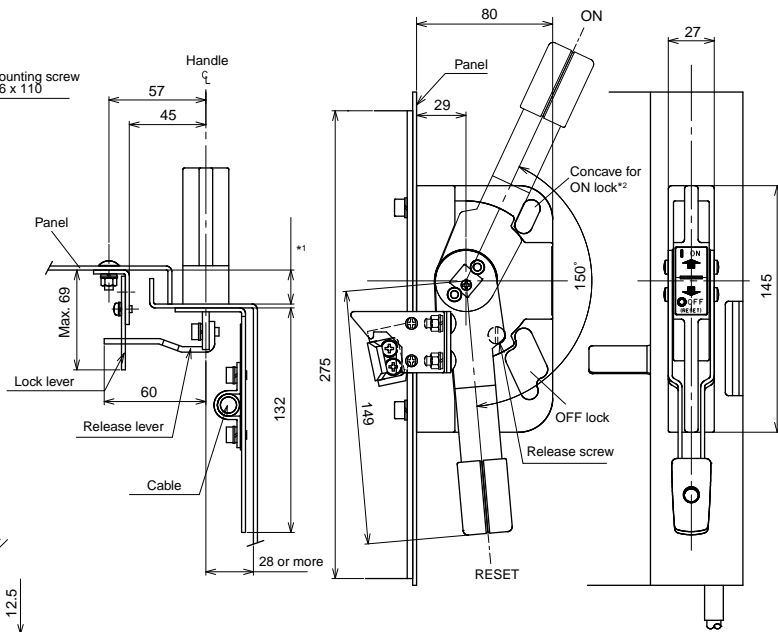

- This product consists of a drive section and an operation section.
- The operation section can be mounted either to the right or to the left on the panel depending on the mounting position of the release lever.
- For the OFF lock, 3 ø10 padlocks can be mounted; for the ON lock, 2 ø10 padlocks.
- \*1 Set the height to 20 or 30. Adjust the lock lever depending on the setting.
- \*2 The ON lock can be realized by additionally creating a concave for the ON lock.

ELCB *	Handle type	Cable		Terminal cover
		Type	Length (m)	
EW125JAGU-3P EW125RAGU-3P	<b>BW9F0CA</b>	<b>BW9FWCA-15A</b> <b>BW9FWCA-20A</b> <b>BW9FWCA-30A</b>	1.5 2.0 3.0	<b>BW9FBTCA-L3</b>
EW250JAGU-3P EW250RAGU-3P	<b>BW9F0GA</b>	<b>BW9FWGA-15A</b> <b>BW9FWGA-20A</b> <b>BW9FWGA-30A</b>	1.5 2.0 3.0	<b>BW9FBTGA-L3</b>
EW400SAGU-3P EW400RAGU-3P EW400HAGU-3P	<b>BW9F0HA</b>	<b>BW9FWHA-15A</b> <b>BW9FWHA-20A</b> <b>BW9FWHA-30A</b>	1.5 2.0 3.0	<b>BW9FBTHA-L3</b>

Note: \* Not available for BW125JAGU-2P

### Steel enclosures

#### ■ Description

Steel enclosures are available in three types — two with V-type handle which allows the operation from the outside and other with the operating handle of the breaker extending from it to allow it to be directly switched ON or OFF from outside the enclosure.

Enclosures with V-type handles are provided with a door interlocking mechanism which prevents the door from being opened in the ON condition.

Knockout holes for wiring use are provided as shown in the diagram.



#### ■ Type of enclosures

ELCB	Enclosure		
	Standard *1	With V-type handle Dust-proof *1*2	Rain-proof *1*2
EW32 EW50 EW63	<b>BZ6C10C2</b> *3 <b>BZ6C10C3</b>	<b>BW9UVBA-3A</b> *3	<b>BW9UWBA-3A</b> *3
EW100	<b>BZ6C25C2</b> *3 <b>BZ6C25C3</b> *3	<b>BW9UVBA-3B</b> *3	<b>BW9UWBA-3B</b> *3
EW125	<b>BW9UCCA-2</b> <b>BW9UCCA-3</b>	<b>BW9UVCA-3</b>	<b>BW9UWCA-3</b>
EW250	<b>BW9UCGA-3</b>	<b>BW9UVGA-3</b>	<b>BW9UWGA-3</b>
EW400	<b>BZ-C60B</b>	<b>BW9UVHA-3</b>	<b>BW9UWHA-3</b>
EW630 EW800	<b>BZ-C70B</b>	<b>BW9UVJA-3</b>	—

\*1 No models are available for four-pole products.

\*2 The appearance of dust-proof and rain-proof models differs from the photograph (400A frames and higher).

\*3 Combination with external accessories(R) is not possible.

#### ■ Ordering information

Specify the following:

1. Type number of enclosures

# Earth leakage Circuit Breakers

## G-TWIN series

### External accessories

#### ■ Dimensions, mm

Fig.1 Standard

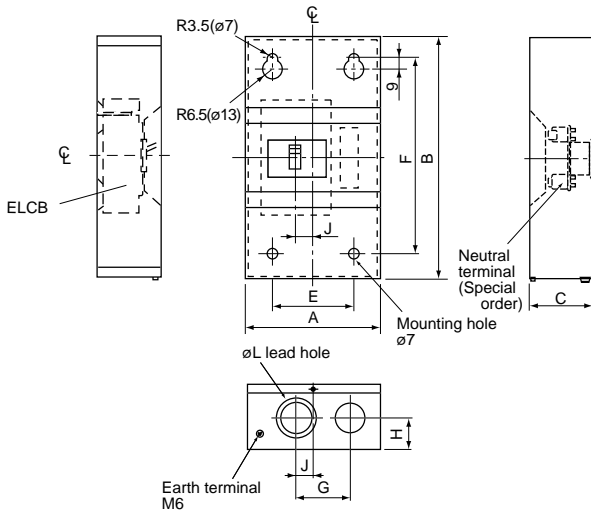

Fig.2 With V type handle  
BW9UVBA-3A, BW9UVBA-3B  
BW9UVCA-3, BW9UVGA-3

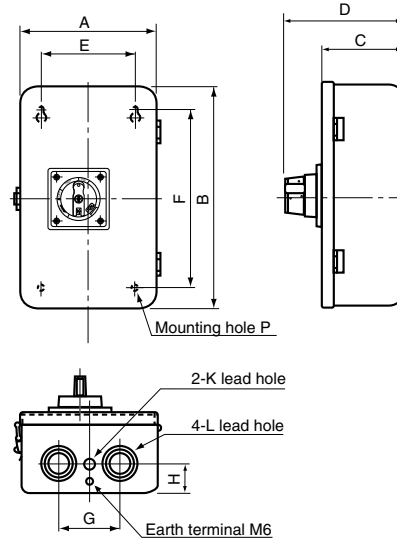
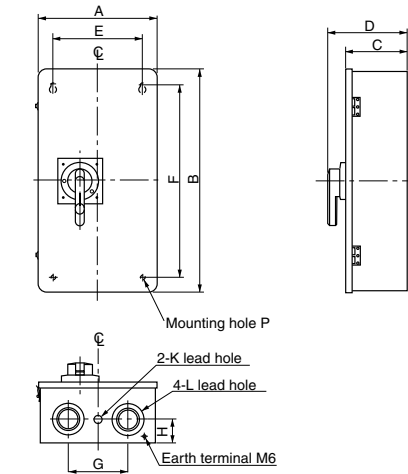
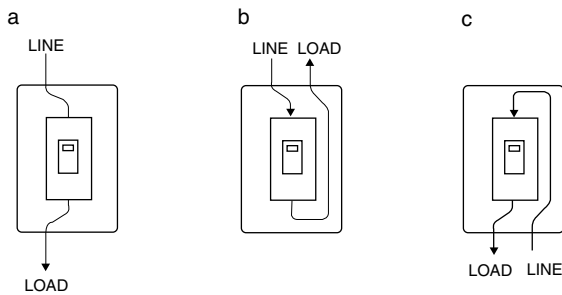

Fig.3. With V type handle  
BW9UVHA-3, BW9UVJA-3



#### ■ Connection method diagrams



Type	Connection	Fig.	A	B	C	D	E	F	G	H	J	K	L	P	
<b>BZ6C10C2</b>	a, b, c	1	135	225	95	—	90	170	65	40	25	—	ø35, ø22	—	
<b>BZ6C10C3</b>			200	320	95	—	120	240	80	40	25	—	ø45, ø30	—	
<b>BZ6C25C3</b>			200	320	103	—	120	240	80	40	25	—	ø45, ø30	—	
<b>BW9UCCA-3</b>			360	—	—	—	280	—	—	—	—	—	—	ø55, ø40	—
<b>BW9UCGA-3</b>			400	750	175	—	300	650	200	80	100	—	—	ø106, ø78, ø63	—
<b>BZ-C60B</b> <b>BZ-C70B</b>			—	—	—	—	—	—	—	—	—	—	—	—	—
<b>BW9UVBA-3A</b>	2	2	180	300	114	178.5	100	220	70	40	—	—	ø28, ø35, ø43	ø7	
<b>BW9UVBA-3B</b>			250	400	142	206.5	170	320	110	50	—	ø23	ø35, ø52, ø63	ø9	
<b>BW9UVCA-3</b>			—	—	—	207	—	—	—	—	—	—	—	—	
<b>BW9UVGA-3</b>	3	3	400	750	206	269	300	650	200	80	—	ø28	ø63, ø78, ø106	ø12	
<b>BW9UVHA-3</b> <b>BW9UVJA-3</b>			—	—	—	—	—	—	—	—	—	—	—	—	

### Terminal covers

#### ■ Description

These terminal covers are used as guards to prevent accidental touch with live line terminations. These terminal covers can be fitted to either line or load side.

#### ● Up to 400AF

**Short type:** BW9BT □ A-S □

- Snap-on fitting

**Long type:** BW9BT □ A-L □

- Crimp connection use

#### ● 630, 800AF

**Long type:** BW9BTJA-L □

- Transparent

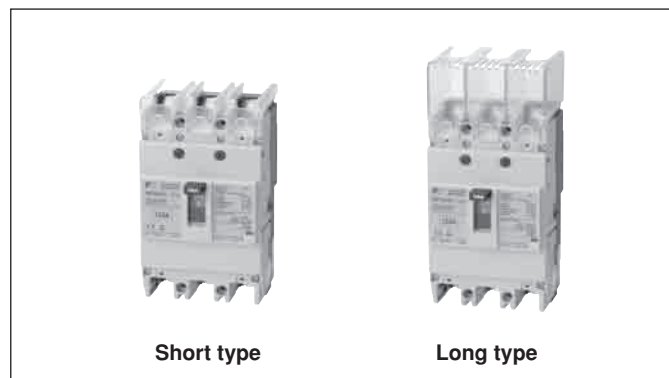

### Long type

Type		No. of poles	ELCB	Dimensions (mm)			Packing quantity	Appearance
Transparent	Gray			A	B	C		
BW9BTAA-L2	BW9BTAA-L2W	2	EW32□-2P EW50□-2P	50	40	53	2	<ul style="list-style-type: none"> <li>• Preventing exposure of live section when amplifier's terminals are connected</li> <li>• Snap-on mounting</li> </ul> 
BW9BTAA-L3	BW9BTAA-L3W	2, 3	EW32□-3P EW50□-3P EW63□-3P EW100□-2P EW100□-3P	75	40	53	2	
BW9BTCA-L3	BW9BTCA-L3W	3	EW125□-3P	90	40	66.5	2	
BW9BTCA-C3 (For Flat terminal)	—	3	EW125□-3P	90	60	66.5	2	
BW9BTCA-L4	BW9BTCA-L4W	4	EW125□-4P	120	40	66.5	2	
BW9BTGA-L3 * <sup>1</sup>	BW9BTGA-L3W * <sup>1</sup>	3	EW160□-3P EW250□-3P	105	50	66.5	2	
BW9BTGA-L4 * <sup>1</sup>	BW9BTGA-L4W * <sup>1</sup>	4	EW160□-4P EW250□-4P	140	50	66.5	2	
BW9BTGA-C3 (For Flat terminal)	—	3	BW250□-3P	105	75	66.5	2	
BW9BTHA-L3 * <sup>2</sup>	BW9BTHA-L3W * <sup>1</sup>	3	EW400□-3P	172	110	98	2	
BW9BTHA-L4 * <sup>2</sup>	—	4	EW400□-4P	220	110	98	2	
BW9BTJA-L3	BW9BTJA-L3W	3	EW630□-3P EW800□-3P	230	135	97.5	2	

### Short type

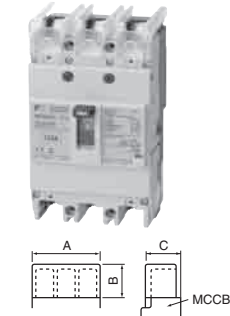
Type		No. of poles	ELCB	Dimensions (mm)			Packing quantity	Appearance
Transparent	Gray			A	B	C		
BW9BTAA-S2	BW9BTAA-S2W	2	EW32□-2P EW50□-2P	50	10	53	2	<ul style="list-style-type: none"> <li>• Preventing exposure of live section when amplifier's terminals are connected</li> <li>• Snap-on mounting</li> </ul> 
BW9BTAA-S3	BW9BTAA-S3W	2, 3	EW32□-3P EW50□-3P EW63□-3P EW100□-2P EW100□-3P	75	10	53	2	
BW9BTCA-S3P20	BW9BTCA-S3WP20	3	EW125□-3P	90	8	66.5	2	
BW9BTCA-S4P20	BW9BTCA-S4WP20	4	EW125□-4P	120	8	66.5	2	
BW9BTGA-S3P20 * <sup>1</sup>	BW9BTGA-S3WP20 * <sup>1</sup>	3	EW160□-3P EW250□-3P	105	8	66.5	2	
BW9BTGA-S4P20 * <sup>1</sup>	BW9BTGA-S4WP20 * <sup>1</sup>	4	EW160□-4P EW250□-4P	140	8	66.5	2	
BW9BTHA-S3 * <sup>3</sup>	BW9BTHA-S3W * <sup>2</sup>	2, 3	EW400□-2P EW400□-3P	140	65	98	2	
BW9BTHA-S4 * <sup>3</sup>	BW9BTHA-S4W * <sup>2</sup>	4	EW400□-4P	185	65	98	2	

Notes: • A gray-white terminal cover comes standard with the Global Series 125AF and 250AF.

\*<sup>1</sup> When using the external operating handle, part of the terminal cover (  ) must be cut away.

\*<sup>2</sup> Crimp terminals for 325 mm<sup>2</sup> are not available.

\*<sup>3</sup> This type of cover can be mounted on the 400AF when flat terminals are not used.

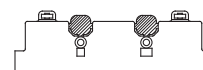

# Earth leakage Circuit Breakers

## G-TWIN series

### External accessories

#### Insulation barriers

##### ■ Description

The interphase barriers are provided on frame size of 32AF to 800AF breakers for front mounting. The barriers are installed in the molded slots between terminals.

The earth barrier is used to increase the insulation with the mounting plate surface when two crimp terminals are wired. Installation of these barriers after wiring is possible even when an external accessory is installed.

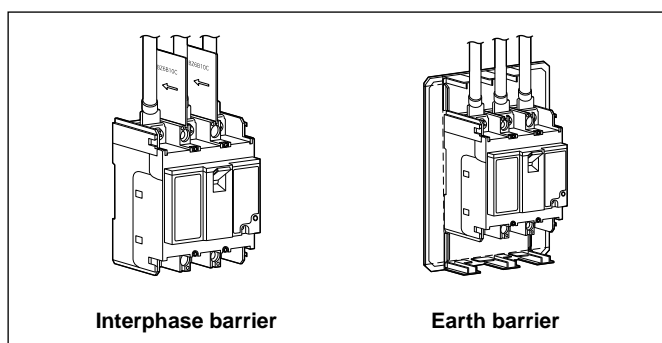

#### Interphase barrier

ELCB	Interphase barrier				
	Type	Dimensions (mm)		Packing quantity	Mass (g)
		A	B		
EW32 EW50 EW63 EW100	<b>BZ6B10C</b>	50	49	4	23
EW125	<b>BW9BPCA</b>	50	60	2	15
EW160 EW250	<b>BW9BPGA</b>	80	60	2	25
EW400 EW630 EW800	<b>B-43A</b>	105	95	4	130

Interphase barrier

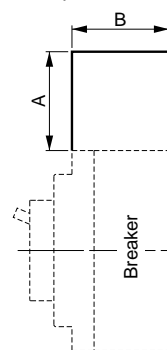

#### Earth barrier

ELCB	Earth barrier				
	Type	Dimensions (mm)		Packing quantity	Mass (g)
		A	B		
EW32□-2P EW50□-2P	<b>BZ6BL10C2</b>	100 (50, 75) <sup>*1</sup>	43 (30) <sup>*1</sup>	1	33
EW32□-3P EW50□-3P EW63□-3P EW100□-2P EW100□-3P	<b>BZ6BL10C3</b>	125 (75, 100) <sup>*1</sup>	43 (30) <sup>*1</sup>	1	41

Earth barrier

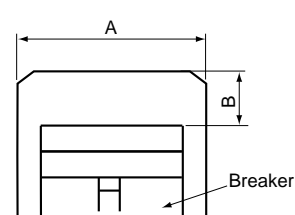

Note: <sup>\*1</sup> Can be cut to dimensions

**Padlocking device and handle locking cover**

■ **Description**

• **Padlocking device**

These padlocking device lock the Breaker handle in the OFF position. Use a commercially available padlock with a shackle diameter of 3.5 to 5mm (5mm for the BZ6L10CA).

• **Handle locking covers (Order Separately)**

These simple handle locking covers can be easily installed by the user. Tripping is possible while the Breaker is locked ON.

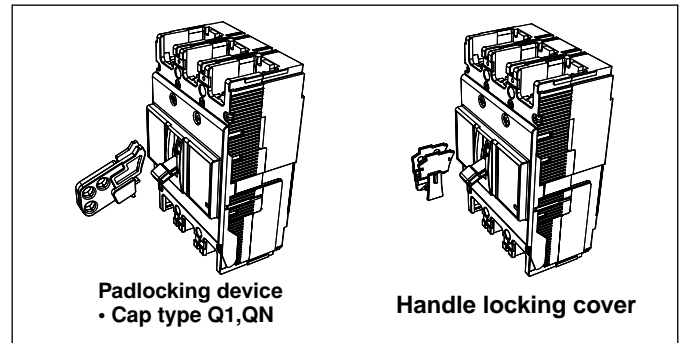

ELCB	Padlocking device			Handle locking cover
	Q1: Cap type	QN: Scissors type	Q2: Plate type	
EW32 EW50 EW63 EW100	<b>BZ6L10CA</b>	—	▲ *1*3	<b>BZ6L10C</b>
EW125 EW160 EW250	<b>BW9Q1CA</b> *4		<b>BW9Q2CA</b> <b>BW9Q2GA</b>	<b>BW9L1CA</b>
EW400 EW630 EW800	▲ *1	<b>BW9QNHA</b> *2	<b>BW9Q2HA</b> <b>BW9Q2JA</b>	<b>BW9L1HA</b>

Notes:

\*1 Specify Locks when ordering the Breaker. (▲: Factory-mounted)

\*2 ON and OFF locking is possible.

\*3 If a padlock is required, use a commercially available padlock with the dimensions shown in the diagram at the right.

\*4 Three padlocks with shackles \*3 to 8 mm in diameter can be attached.

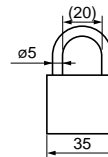

**Padlocking device**

• **Cap type Q1**

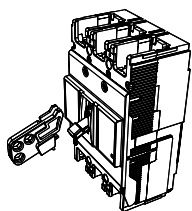

• **Plate type Q2**

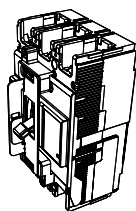

**Handle locking cover**

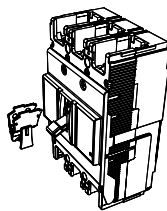

**Q1: BZ6L10CA (OFF-locking Padlocking device)**

