

## NEW! PAN1720 SERIES BLUETOOTH® LOW ENERGY

### Bluetooth Smart Low Energy RF Module with Antenna

Introducing the **NEW PAN1720 Series**, a complete *Bluetooth* 4.0 Low Energy solution. Modules in this Series include an embedded processor, antenna and *Bluetooth* Low Energy stack.

The **NEW PAN1720 Series** is a cost-effective, low-power, true system-on-chip (SoC) for *Bluetooth* Low Energy applications. The module includes an eight channel, twelve bit analog-to-digital converter, 19 GPIOs plus battery and temperature sensors. A single device for both *Bluetooth* Low Energy master or slave nodes. The **PAN1720 Series** combines an excellent RF transceiver with a high performance low power 8051 microcontroller, in-system programmable flash memory, 8-KB RAM, and many other powerful supporting features and peripherals.

The **PAN1720 Series** is an ideal choice for applications where battery life is a critical application requirement, using only 500 nA in sleep mode. Short transition times between operating modes – 3µS Wake-Up – and power efficient hardware further reduce current consumption.

Applications and *Bluetooth* Low Energy protocol stack from Texas Instruments, run on the **PAN1720 Series** to form a very flexible and cost-effective single-mode *Bluetooth* Low Energy solution.

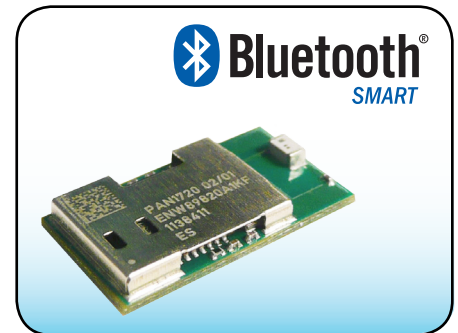

### Product Performance:

- *Bluetooth* 4.0 Compliant and *Bluetooth* Low Energy
- Dimensions: 14.5x 8.2 x 3 mm
- Supports User Developed Applications
- Texas Instruments' Stack or Optional *BlueRadios*™ Stack
- 256K Flash, 8K RAM
- Certifications: Bluetooth, FCC, IC and CE
- 1Mbps Datarate
- Temperature Range -40°C to + 85°C
- Eight Channel 12-Bit ADC
- 19 GPIOs
- Battery Monitor and Temperature Sensor

### PAN1720 Part Numbers:

Part Numbers	Description
ENW-89820A1KF	PAN1720, CC2540 <i>Bluetooth</i> Low Energy with 8051 Controller, Texas Instruments' Stack
ENW-89820A3KF	PAN1720, CC2540 <i>Bluetooth</i> Low Energy with 8051 Controller, <i>BlueRadios</i> ™ Stack
EVAL_PAN1720	<i>Bluetooth</i> , PAN1720, Evaluation Kit, Includes Two PAN1720 USB Development Modules
EVAL_PAN1720-BR	<i>Bluetooth</i> , PAN1720, Evaluation Kit, Includes Two PAN1720 USB Development Modules, <i>BlueRadios</i> ™ FW

### Compatible Part Number:

Part Numbers	Description
ENW-89823A2JF	PAN1326, CC2564, <i>Bluetooth</i> & <i>Bluetooth</i> Low Energy, HCI module, antenna

The *Bluetooth*® word mark and logos are registered trademarks owned by Bluetooth SIG, Inc. and any use of such marks by Panasonic Corporation of North America is under license. Other trademarks and trade names are those of their respective owners.

**Panasonic ideas for life**

### Interfaces:

The PAN1720 Interface supports:

- Two Powerful USARTs with Support for Several Serial Protocols
- Full Speed USB 2.0 Interface
- 19 General-Purpose I/O Pins (17x4mA, 2x20mA)
- 12-Bit ADC with Eight Channels and Configurable Resolution

### Applications:

- 2.4 GHz *Bluetooth* Low Energy Systems
- Proprietary 2.4 GHz Systems
- Human Interface Devices
- Sports and Leisure Equipment
- Mobile Phone Accessories
- Consumer Electronics
- USB Dongles
- Health Care and Medical

### Block Diagram PAN1720:

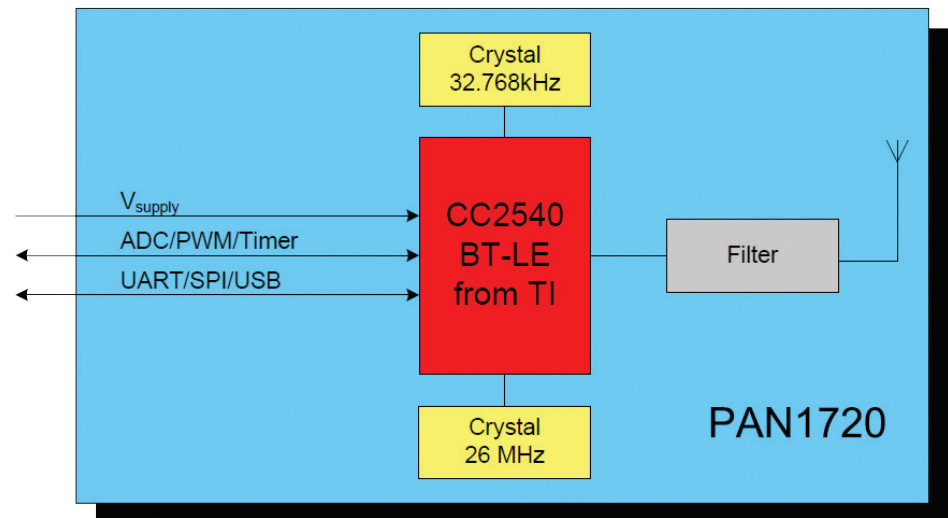

### Evaluation Kits:

#### EVAL\_PAN1720

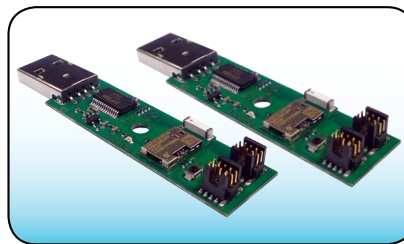

#### EVAL\_PAN1720-BR



### Technical Specifications for PAN1720:

Parameter	Value	Condition / Notes
Receiver Sensitivity (1% PER)	-96 dBm	@ 500 kbps / MSK (High-Gain Mode)
Output Power	+4 dBm typ.	Maximum Setting
Power Supply	2.0 - 3.6 V	Single Operation Voltage
Sleep Mode	0.5 uA	Power Mode 3 (Lowest)
Transmit Mode	40 mA	@ 0dBm (Peak Current)
Receive Mode	37 mA	Standard Mode
Operating Temperature Range	-40°C to + 85°C	Industrial Range

The *Bluetooth*® word mark and logos are registered trademarks owned by Bluetooth SIG, Inc. and any use of such marks by Panasonic Corporation of North America is under license. Other trademarks and trade names are those of their respective owners.

**Panasonic ideas for life**