

### Thick Film Chip Resistors 0201, 0402, 0603, 0805, 1206, 1210, 1812, 2010, 2512

Type: **ERJ 1G, 2G, 3G, 6G, 8G, 14, 12, 12Z, 1T**

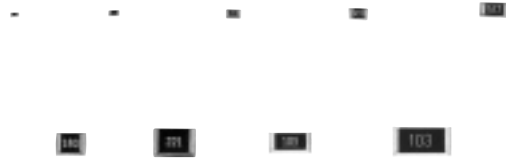

#### ■ Features

- Small size and lightweight  
For PCB size reduction and lightweight products
- High reliability  
Metal glaze thick film resistive element and three layers of electrodes result in high reliability
- Matching with placement machine  
Taping and bulk case packagings for automatic placement machine
- Solderability  
Suitable for both reflow soldering and flow soldering
- Reference Standards  
IEC 60115-8, JIS C 5201-8, EIAJ RC-2134A

#### ■ Explanation of Part Numbers

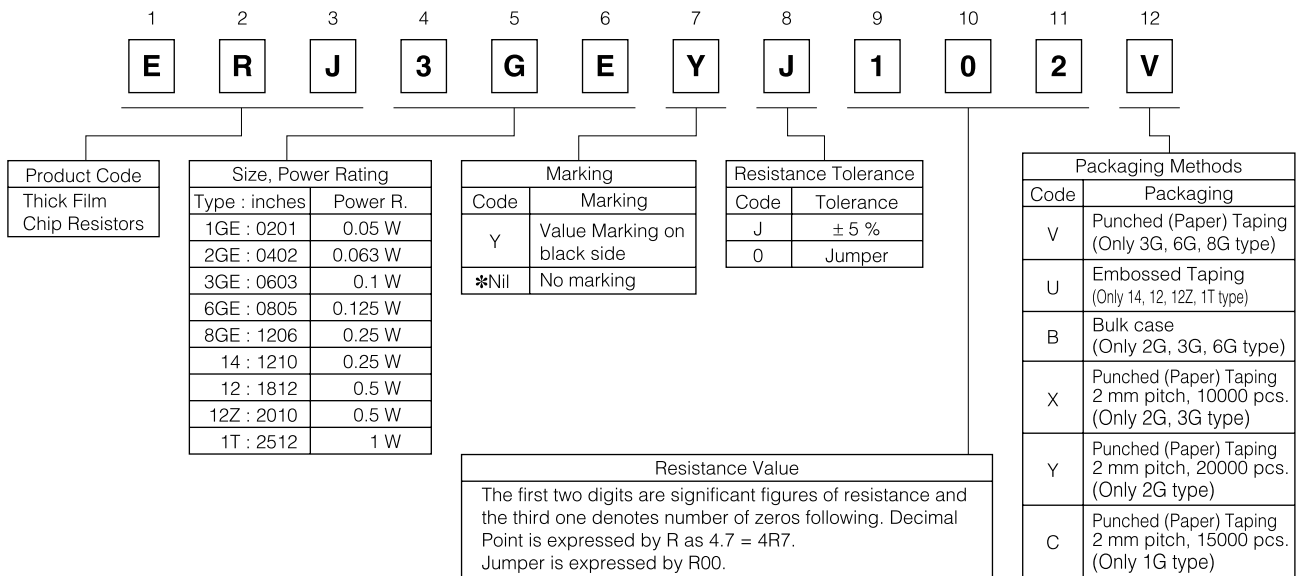

\* When omitted, all the rest P/N factors shall be moved up respectively.

### Construction

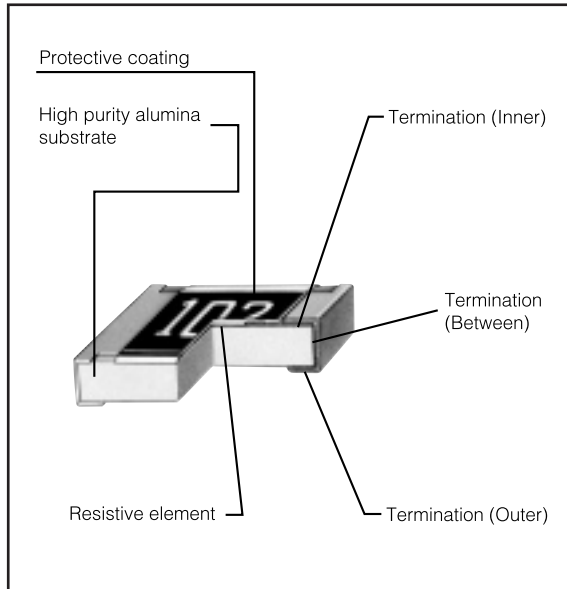

### Dimensions in mm (not to scale)

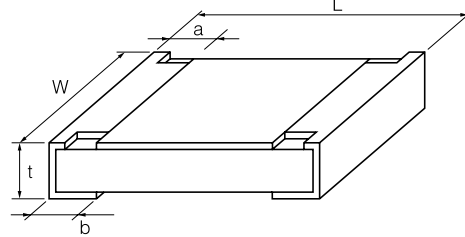

Type (inches)	Dimensions (mm)					Weight (1000 pcs.)
	L	W	a	b	t	
ERJ1G (0201)	0.60 <sup>+0.03</sup>	0.30 <sup>+0.03</sup>	0.12 <sup>+0.05</sup>	0.15 <sup>+0.05</sup>	0.25 <sup>+0.05</sup>	0.15 g
ERJ2G (0402)	1.00 <sup>+0.05</sup>	0.50 <sup>+0.05</sup>	0.20 <sup>+0.10</sup>	0.25 <sup>+0.05</sup>	0.35 <sup>+0.05</sup>	0.8 g
ERJ3G (0603)	1.60 <sup>+0.15</sup>	0.80 <sup>+0.15</sup> <sub>-0.05</sub>	0.30 <sup>+0.20</sup>	0.30 <sup>+0.15</sup>	0.45 <sup>+0.10</sup>	2 g
ERJ6G (0805)	2.00 <sup>+0.20</sup>	1.25 <sup>+0.10</sup>	0.40 <sup>+0.20</sup>	0.40 <sup>+0.20</sup>	0.60 <sup>+0.10</sup>	4 g
ERJ8G (1206)	3.20 <sup>+0.25</sup>	1.60 <sup>+0.15</sup> <sub>-0.05</sub>	0.50 <sup>+0.20</sup>	0.50 <sup>+0.20</sup>	0.60 <sup>+0.10</sup>	10 g
ERJ14 (1210)	3.20 <sup>+0.20</sup>	2.50 <sup>+0.20</sup>	0.50 <sup>+0.20</sup>	0.50 <sup>+0.20</sup>	0.60 <sup>+0.10</sup>	16 g
ERJ12 (1812)	4.50 <sup>+0.20</sup>	3.20 <sup>+0.20</sup>	0.50 <sup>+0.20</sup>	0.50 <sup>+0.20</sup>	0.60 <sup>+0.10</sup>	27 g
ERJ12Z (2010)	5.00 <sup>+0.20</sup>	2.50 <sup>+0.20</sup>	0.60 <sup>+0.20</sup>	0.60 <sup>+0.20</sup>	0.60 <sup>+0.10</sup>	27 g
ERJ1T (2512)	6.40 <sup>+0.20</sup>	3.20 <sup>+0.20</sup>	0.65 <sup>+0.20</sup>	0.60 <sup>+0.20</sup>	0.60 <sup>+0.10</sup>	45 g

### Ratings

Type (inches)	Power Rating at 70 °C (W)	Limiting Element Voltage (Maximum RCWV <sup>(1)</sup> (V))	Maximum Overload Voltage <sup>(2)</sup> (V)	Resistance Tolerance(%)	Resistance Range (Ω)		T.C.R. × 10 <sup>-6</sup> /°C (ppm/°C)	Standard Resistance Values
					min.	max.		
ERJ1G (0201)	0.05	15	30	± 5	10	1 M	<10 Ω: -100 to +600	E24
ERJ2G (0402)	0.063	50	100	± 5	1	2.2 M		E24
ERJ3G (0603)	0.1	50	100	± 5	1	10 M		E24
ERJ6G (0805)	0.125	150	200	± 5	1	10 M	10 Ω to 1 MΩ: ±200	E24
ERJ8G (1206)	0.25	200	400	± 5	1	10 M		E24
ERJ14 (1210)	0.25	200	400	± 5	1	10 M	1 MΩ<: -400 to +150	E24
ERJ12, 12Z (1812, 2010)	0.5	200	400	± 5	1	10 M		E24
ERJ1T (2512)	1	200	400	± 5	1	1 M	E24	

		Rated Current	Maximum Overload Current
Jumper	1G	0.5 A	1 A
	2G · 3G	1 A	2 A
	6G · 8G · 14 · 12 · 12Z · 1T	2 A	4 A

(1) Rated Continuous Working Voltage (RCWV) shall be determined from  $RCWV = \sqrt{\text{Power Rating} \times \text{Resistance Values}}$ , or Limiting Element Voltage (max. RCWV) listed above, whichever less.

(2) Overload (Short-time Overload) Test Voltage (SOTV) shall be determined from  $SOTV = 2.5 \times \text{Power Rating}$  or max. Overload Voltage listed above whichever less.

### Power Derating Curve

For resistors operated in ambient temperatures above 70 °C, power rating shall be derated in accordance with the right figure.

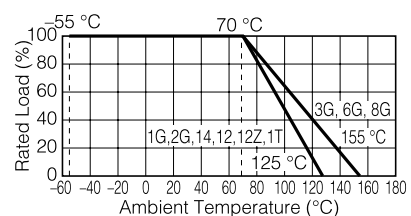

### ■ Packaging Methods

#### ● Standard Quantity

Type (inches)	Thickness (mm)	Punched (Paper) Taping	Embossed Taping (4 mm pitch)	Bulk Case
ERJ1G (0201)	0.25	15000 pcs./reel (2 mm pitch)		
ERJ2G (0402)	0.35	10000 pcs./reel (2 mm pitch) 20000 pcs./reel (2 mm pitch)		50000 pcs./case
ERJ3G (0603)	0.45	10000 pcs./reel (2 mm pitch) 5000 pcs./reel (4 mm pitch)*		25000 pcs./case
ERJ6G (0805)	0.6	5000 pcs./reel (4 mm pitch)*		10000 pcs./case
ERJ8G (1206)	0.6	5000 pcs./reel (4 mm pitch)*		
ERJ14 (1210)	0.6		5000 pcs./reel	
ERJ12,12Z (1812,2010)	0.6		5000 pcs./reel	
ERJ1T (2512)	0.6		4000 pcs./reel	

\* Please ask us when resistors except standard specification shown above table are needed.

#### ● Taping Reel

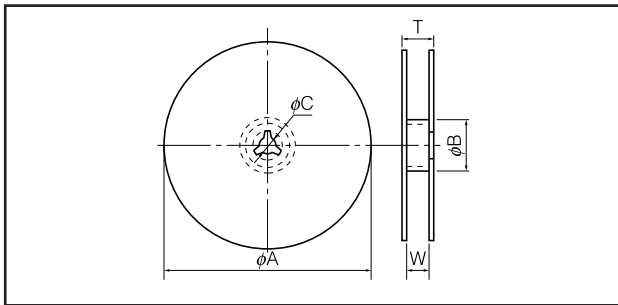

Dimensions (mm)	Type	φA	φB	φC	W	T
	1G,2G,3G	180.0 <sup>+0.0</sup> <sub>-3.0</sub>	60 min.	13.0 <sup>±1.0</sup>	9.0 <sup>±1.0</sup>	11.4 <sup>±2.0</sup>
	6G,8G,14				13.0 <sup>±1.0</sup>	15.4 <sup>±2.0</sup>
12,12Z,1T						

#### ● Bulk Case

(mm)

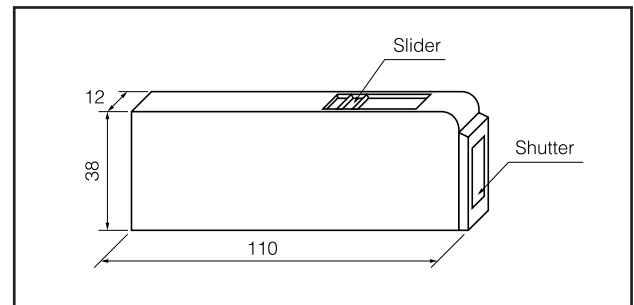

#### ● Punched (Paper) Taping

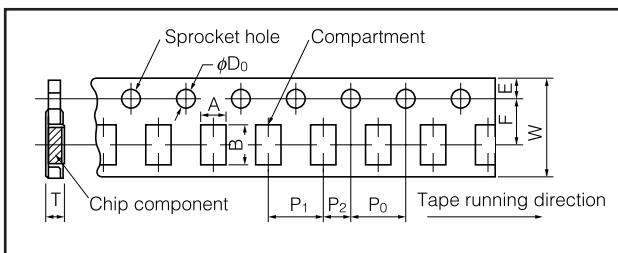

Dimensions (mm)	Type	A	B	W	F	E
	1G	0.38 <sup>+0.05</sup>	0.68 <sup>+0.05</sup>			
	2G	0.70 <sup>+0.05</sup>	1.20 <sup>+0.05</sup>			
	3G	1.10 <sup>+0.10</sup>	1.90 <sup>+0.10</sup>	8.00 <sup>±0.20</sup>	3.50 <sup>+0.05</sup>	1.75 <sup>±0.10</sup>
	6G	1.65 <sup>+0.15</sup>	2.50 <sup>+0.20</sup>			
	8G	2.00 <sup>+0.15</sup>	3.60 <sup>+0.20</sup>			

Dimensions (mm)	Type	P <sub>1</sub>	P <sub>2</sub>	P <sub>0</sub>	φD <sub>0</sub>	T
	1G	2.00 <sup>±0.10</sup>		4.00 <sup>±0.10</sup>	1.50 <sup>+0.10</sup> <sub>0</sub>	0.47 <sup>±0.05</sup>
	2G					0.52 <sup>±0.05</sup>
	3G	4.00 <sup>±0.10</sup>	2.00 <sup>±0.05</sup>	4.00 <sup>±0.10</sup>	1.50 <sup>+0.10</sup> <sub>0</sub>	0.70 <sup>±0.05</sup>
	6G					0.84 <sup>±0.05</sup>
8G						

#### ● Embossed Taping

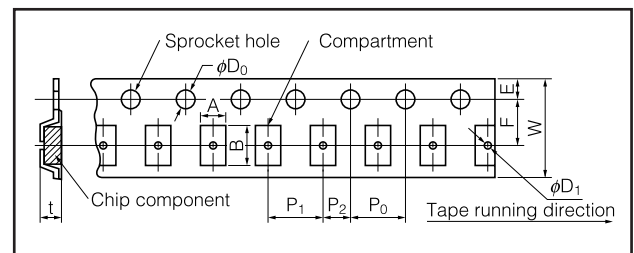

Dimensions (mm)	Type	A	B	W	F	E	P <sub>1</sub>
	14	2.80 <sup>±0.20</sup>	3.50 <sup>±0.20</sup>	8.00 <sup>±0.30</sup>	3.50 <sup>±0.05</sup>		
	12	3.50 <sup>±0.20</sup>	4.80 <sup>±0.20</sup>	12.00 <sup>±0.30</sup>	5.50 <sup>±0.05</sup>	1.75 <sup>±0.10</sup>	4.00 <sup>±0.10</sup>
	12Z	2.80 <sup>±0.20</sup>	5.30 <sup>±0.20</sup>				
1T	3.60 <sup>±0.20</sup>	6.90 <sup>±0.20</sup>					

Dimensions (mm)	Type	P <sub>2</sub>	P <sub>0</sub>	φD <sub>0</sub>	t	φD <sub>1</sub>
	14	2.00 <sup>±0.05</sup>	4.00 <sup>±0.10</sup>	1.50 <sup>+0.10</sup> <sub>0</sub>	1.00 <sup>±0.10</sup>	1 min.
	12					
	12Z					
1T					1.5 min.	

Design, Specifications are subject to change without notice. Ask factory for technical specifications before purchase and/or use. Whenever a doubt about safety arises from this product, please inform us immediately for technical consultation without fail.

### ■ Recommended Land Pattern

In the case of flow soldering, the land width must be smaller than the Chip Resistor width to control the solder amount properly. Generally, the land width should be 0.7 to 0.8 times (W) of the width of chip resistor. In the case of reflow soldering, solder amount can be adjusted, therefore the land width should be set to 1.0 to 1.3 times chip resistor width (W).

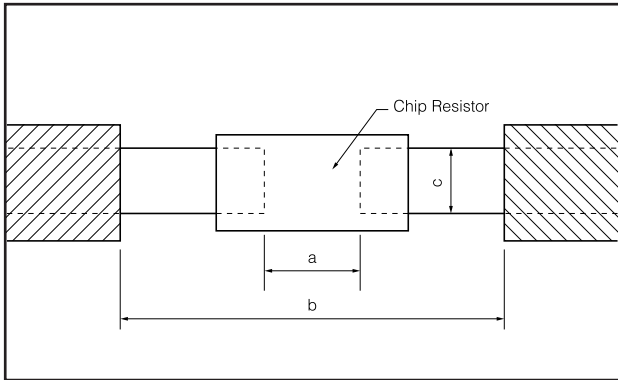

Type (inches)	Dimensions (mm)		
	a	b	c
ERJ1G(0201)	0.3 to 0.4	0.8 to 0.9	0.25 to 0.35
ERJ2G(0402)	0.5 to 0.6	1.4 to 1.6	0.4 to 0.6
ERJ3G(0603)	0.7 to 0.9	2 to 2.2	0.8 to 1
ERJ6G(0805)	1 to 1.4	3.2 to 3.8	0.9 to 1.4
ERJ8G(1206)	2 to 2.4	4.4 to 5	1.2 to 1.8
ERJ14(1210)	2 to 2.4	4.4 to 5	1.8 to 2.8
ERJ12(1812)	3.3 to 3.7	5.7 to 6.5	2.3 to 3.5
ERJ12Z(2010)	3.6 to 4	6.2 to 7	1.8 to 2.8
ERJ1T(2512)	5 to 5.4	7.6 to 8.6	2.3 to 3.5

### ■ Recommended Soldering Conditions

Recommendations and precautions are described below.

#### ● Recommended soldering conditions for reflow

- Reflow soldering shall be two times maximum.
- Please contact us for additional information when you use in conditions other than those specified.
- Please measure a temperature of terminations and study solderability every kind of solder and board, before actual use.

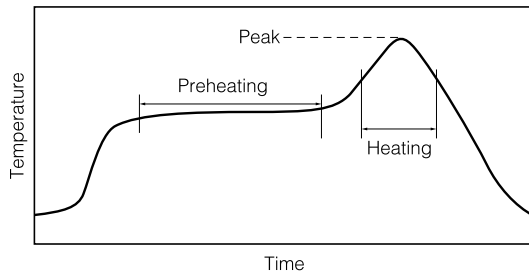

For solder (Example : Sn/Pb)

	Temperature	Time
Preheating	140 °C to 160 °C	60 s to 120 s
Main heating	Above 200 °C	30 s to 40 s
Peak	235 ± 5 °C	max. 10 s

For lead-free solder (Example : Sn/Ag/Cu)

	Temperature	Time
Preheating	150 °C to 180 °C	60 s to 120 s
Main heating	Above 230 °C	30 s to 40 s
Peak	max. 260 °C	max. 10 s

#### ● Recommended soldering conditions for flow

	For solder		For lead-free solder	
	Temperature	Time	Temperature	Time
Preheating	140 °C to 160 °C	60 s to 120 s	150 °C to 180 °C	60 s to 120 s
Soldering	245±5 °C	20 s to 30 s	max. 260 °C	max. 10 s

### ⚠ Cautions for Safety

1. If transient load (heavy load in a short time) like pulse is expected to be applied, carry out evaluation and confirmation test with the resistors actually mounted on your own board.  
When the load of more than rated power is applied under the load condition at steady state, it may impair performance and/or reliability of resistor.  
Never exceed the rated power.
2. Chlorine type or other high-activity flux is not recommended as the residue may affect performance or reliability of resistors.
3. When soldering with soldering iron, never touch the body of the chip resistor with a tip of the soldering iron. When using a soldering iron with a tip at high temperature, solder for a time as short as possible (three seconds or less up to 350 °C).
4. Avoid physical shock to the resistor and nipping of the resistor with hard tool (a pair of pliers or tweezers) as it may damage protective film or the body of resistor and may affect resistor's performance.