

**AeroPower™ Power Factor Correction
Capacitors**

**SINGLE-PHASE AND THREE-PHASE
PFC CAPACITORS FOR
HIGH RELIABILITY APPLICATIONS**



Intelligent Capacitor Solutions



AeroPower™ power factor correction capacitors are constructed using high quality materials and Lean Six Sigma manufacturing practices to provide reliable performance and long life during continuous use.

CD-Aero capacitors undergo 100% electrical and visual testing to further ensure high level performance. If you have specialized needs, our flexible manufacturing processes allow us to quickly provide custom configurations.



CONTENTS

General Information.....	2
Construction	4
Harmonic Distortion.....	4
Cover Terminals.....	5
Specifications: AMP0, MMP0 and EPFC Capacitors.....	6
Safety Features	10
Mounting Orientation	10
Part Numbering System.....	10
Ratings Tables & Drawings: AMP0, MMP0 and EPFC Capacitors	11
Equations for Reactive Compensation and Harmonic Distortion	22
PFC Capacitor Care, Troubleshooting and Common Issues.....	24

CD-Aero provides intelligent capacitor solutions.



AeroPower™ Power Factor Correction Capacitors

SINGLE-PHASE AND THREE-PHASE PFC CAPACITORS FOR HIGH RELIABILITY APPLICATIONS



CD-Aero manufactures both single-phase and three-phase power factor correction capacitors up to 4,800 VAC. Our AeroPower brand PFC capacitors are designed for high reliability applications, and have a life rating of over 200,000 hours. They are designed to withstand harmonic currents, with special high harmonic versions available.

Three types of standard reactive compensation capacitors are available:

- AMP0: Vacuum-impregnated metallized polypropylene, compact size. Available in both oil-filled and dry configurations. (Made in USA.)
- MMP0: Vacuum-impregnated metallized polypropylene, rugged welded case. (Made in USA.)
- EPFC: Euro-style vacuum-impregnated metallized polypropylene, round aluminum studded case. (Made in China and India.)

Applications

- Power Factor Correction Systems
- Harmonic Filters
- Alternative Energy Power Systems
- Induction Heating Capacitor Alternatives

Custom ratings and sizes are available. Please contact CD-Aero.

Highlights

- Both European and North American styles available
- Long life
- Over-current rating to 150% (200% for 50 Hz EPFC)
- Over-voltage rating to 120%
- Includes discharge resistors
- Large 325 KVAR capacitors available
- Single-phase and three-phase
- Loss of KVAR/fault detection
- Oil or epoxy filled versions available



Specifications

KVAR Range:	0.5 to 325 KVAR
Capacitance Tolerance:	0 to +15%
AC Voltage Range:	240 VAC to 4,800 VAC; single-phase or three-phase
Rated Frequency:	50 or 60 Hz
Capacitor Connection:	3-phase, internal delta connection standard; wye available on request
Operating Life:	100,000–200,000+ hours
Total Losses:	<0.5 Watts / KVAR at 60 Hertz, 25°C
Operating Temperature Range:	-40°C to +46°C
Approval Certification:	UL, cUL (≤600 VAC)

AeroPower™ Power Factor Correction Capacitors

SINGLE-PHASE AND THREE-PHASE PFC CAPACITORS FOR HIGH RELIABILITY APPLICATIONS

Standard Voltage and KVAR Ratings at 60 Hertz*

LOW VOLTAGE	AMPO	EPFC	MMP0
240 VAC	0.5–10	0.5–10	20–30
480 VAC	0.5–25	2–40	25–100
600 VAC	1.0–25	10–40	25–100
750 VAC	–	–	25–150

MEDIUM VOLTAGE	MMP0
900 VAC	25–150
1040 VAC	25–240
1200 VAC	25–240
2400 VAC	25–300
2770 VAC	25–300
4160 VAC	25–300
4800 VAC	25–325

Standard Voltage and KVAR Ratings at 50 Hertz

LOW VOLTAGE	EPFC
400 VAC	2–50
415 VAC	2–50
440 VAC	2–50
480 VAC	5–25
525 VAC	5–25

*Please consult the factory for other voltages, frequencies and KVAR ratings.

Construction

All AeroPower capacitors are impregnated with either a dielectric fluid or an epoxy resin to give added insulation, excellent corona protection and a moisture barrier. The dielectric fluid and the epoxy resin are considered a green (benign), environmentally friendly material. MMP0 and EPFC capacitors are 100% leak tested. CD-Aero products do not contain PCBs.

Harmonic Distortion

Harmonic distortion is the resulting non-sinusoidal current waveform generated by a non-linear load. The most common non-linear load is a pulse rectifier, which is used in most switch mode power supplies, variable speed drives and uninterruptible power supplies. The distorted current waveform generates a distorted source voltage due to the system (electrical power system) impedance. A distorted waveform can be analyzed by decomposing it into a fundamental component (line frequency) and higher frequency components of varying amplitude.

The effects of harmonic distortion on metallized film capacitors are (1) higher operating temperature because of higher I²R losses and (2) higher voltage stress on the dielectric. Both of these factors will shorten the life of a capacitor dramatically.

All CD-Aero power factor correction capacitors are designed to handle harmonic currents, however, CD-Aero also offers capacitors that are custom designed for systems with high harmonic distortion. By using our high-harmonic capacitors in your harmonic rich application, you will have a more robust construction compared to using standard capacitors in the same application.

Cover Terminals

AMPO and low voltage MMP0 cells are available in a three-terminal configuration, specified by KVAR rating (see individual

specifications). The internal schematics for these terminal configurations are shown in Figures 1A and 1B.

Figure 1A: AMPO & Low Voltage MMPO

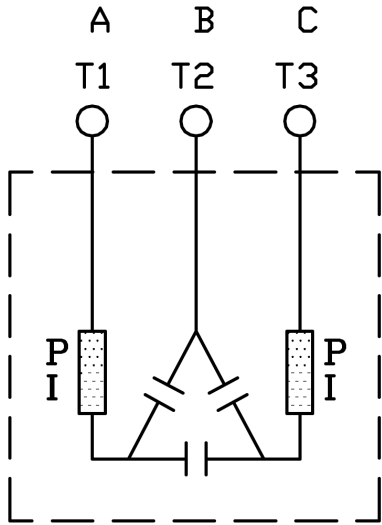
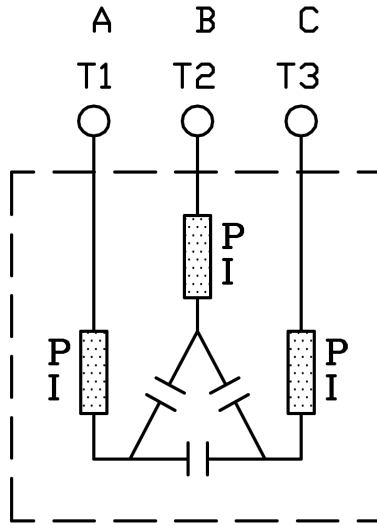

Figure 1B: EPFC



Internal Schematics for Low Voltage
Three-Terminal Capacitors

AeroPower™ Power Factor Correction Capacitors

SINGLE-PHASE AND THREE-PHASE PFC CAPACITORS FOR HIGH RELIABILITY APPLICATIONS

Reactive Power Compensation Capacitor Specifications

	AMP0 Low Voltage (Three-phase and single-phase) (up to 600 VAC)	MMP0 Low Voltage (Three-phase and single-phase) (up to 600 VAC)	MMP0 Low Voltage (Three-phase and single-phase) (750 to 900 VAC)	MMP0 Medium Voltage (Three-phase and single-phase) (1040 to 4800 VAC)	EPFC Low Voltage (Three-phase) (up to 600 VAC) (60 Hz)	EPFC Low Voltage (Three-phase) (up to 525 VAC) (50 Hz)
--	---	---	--	---	---	---

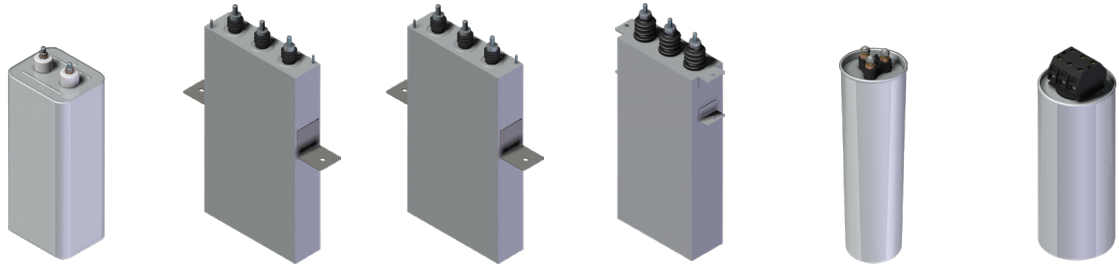





Electrical Characteristics

Rated Voltages	240, 480 and 600 VAC	240, 480 and 600 VAC	750 and 900 VAC	1040, 1200, 2400, 2770, 4160 and 4800 VAC	240, 480 and 600 VAC	400, 415, 440, 480 and 525 VAC
Rated Frequency	60 Hertz	60 Hertz	60 Hertz	60 Hertz	60 Hertz	50 Hertz
Capacitor Type	Fluid impregnated (Dry also available)	Fluid impregnated	Fluid impregnated	Fluid impregnated	Fluid impregnated	Fluid impregnated
Dielectric System	Self-healing metallized polypropylene film	Self-healing metallized polypropylene film	Self-healing metallized polypropylene film	Self-healing metallized polypropylene film	Self-healing metallized polypropylene film	Self-healing metallized polypropylene film
Impregnation Fluid	Non-PCB, non-toxic, biodegradable, Class III combustible fluid	Non-PCB, non-toxic, biodegradable, Class III combustible fluid	Non-PCB, non-toxic, biodegradable, Class III combustible fluid	Non-PCB, non-toxic, biodegradable, Class III combustible fluid	Non-PCB, non-toxic, biodegradable, Class III combustible fluid	Non-PCB, biodegradable, natural oil
Capacitor Connector, 3-phase	Internal delta connection	Internal delta connection	Internal wye connection	Internal delta or wye connection	Internal delta connection	Internal delta connection
Capacitance Tolerance	-0% to +15%	-0% to +15%	-0% to +15%	-0% to +15%	-0% to +15%	-5% to +10%
Discharge Device	External resistors reduce residual voltage to <50 V with in 1 minute	Internal resistors reduce residual voltage to <50 V within 1 minute	Internal resistors reduce residual voltage to <50 V within 5 minutes	Internal resistors reduce residual voltage to <50 V within 5 minutes	Internal resistors reduce residual voltage to <50 V within 1 minute	Internal resistors reduce residual voltage to <50 V within 1 minute
Total Losses	<0.5 Watts / KVAR at 60 Hertz, 25°C	<0.5 Watts / KVAR at 60 Hertz, 25°C	<0.5 Watts / KVAR at 60 Hertz, 25°C	<0.5 Watts / KVAR at 60 Hertz, 25°C	<0.5 Watts / KVAR at 60 Hertz, 25°C (without resistors)	<0.5 Watts / KVAR at 50 Hertz, 25°C (without resistors)
Design Service Life	200,000 hours continuous duty	200,000 hours continuous duty	200,000 hours continuous duty	200,000 hours continuous duty	200,000 hours continuous duty	100,000 hours (150,000 high harmonic)

AeroPower™ Power Factor Correction Capacitors

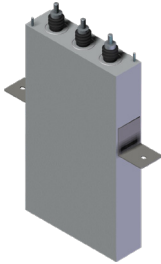
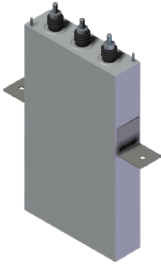
SINGLE-PHASE AND THREE-PHASE PFC CAPACITORS FOR HIGH RELIABILITY APPLICATIONS

Reactive Power Compensation Capacitor Specifications (cont.)

	AMP0 Low Voltage (Three-phase and single-phase) (up to 600 VAC)	MMP0 Low Voltage (Three-phase and single-phase) (up to 600 VAC)	MMP0 Low Voltage (Three-phase and single-phase) (750 to 900 VAC)	MMP0 Medium Voltage (Three-phase and single-phase) (1040 to 4800 VAC)	EPFC Low Voltage (Three-phase) (up to 600 VAC) (60 Hz)	EPFC Low Voltage (Three-phase) (up to 525 VAC) (50 Hz)
						

Over Current

Standard	135% * rated current continuous, includes harmonic currents	135% * rated current continuous, includes harmonic currents	135% * rated current continuous, includes harmonic currents	135% * rated current continuous, includes harmonic currents	135% * rated current continuous, includes harmonic currents	150% * rated current continuous, includes harmonic currents
High Harmonic	150% * rated current continuous, includes harmonic currents	150% * rated current continuous, includes harmonic currents	150% * rated current continuous, includes harmonic currents	150% * rated current continuous, includes harmonic currents	150% * rated current continuous, includes harmonic currents	200% * rated current continuous, includes harmonic currents

Over Voltage

Standard	110% * rated voltage continuous	110% * rated voltage continuous	110% * rated voltage continuous	110% * rated voltage continuous	110% * rated voltage continuous	110% * rated (8 hrs. in every 24 hrs.)
High Harmonic	120% * rated voltage continuous	120% * rated voltage continuous	120% * rated voltage continuous	120% * rated voltage continuous	120% * rated voltage continuous	120% * rated (5 minutes in every 24 hours)

AeroPower™ Power Factor Correction Capacitors

SINGLE-PHASE AND THREE-PHASE PFC CAPACITORS FOR HIGH RELIABILITY APPLICATIONS

Reactive Power Compensation Capacitor Specifications (cont.)

	AMPO Low Voltage (Three-phase and single-phase) (up to 600 VAC)	MMP0 Low Voltage (Three-phase and single-phase) (up to 600 VAC)	MMP0 Low Voltage (Three-phase and single-phase) (750 to 900 VAC)	MMP0 Medium Voltage (Three-phase and single-phase) (1040 to 4800 VAC)	EPFC Low Voltage (Three-phase) (up to 600 VAC) (60 Hz)	EPFC Low Voltage (Three-phase) (up to 525 VAC) (50 Hz)
--	---	---	--	---	---	---

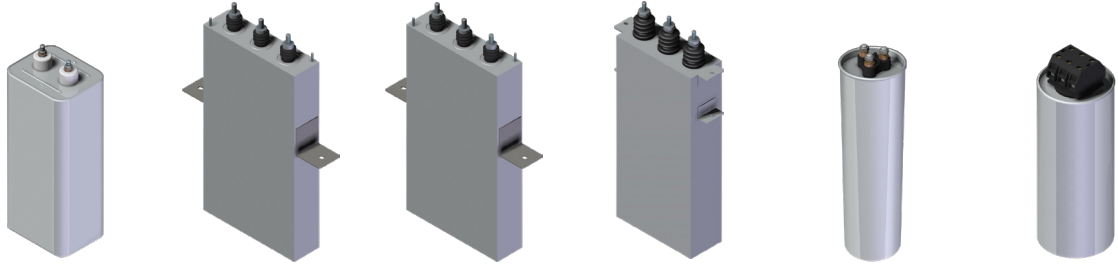





Mechanical Characteristics

Enclosure Type	Drawn tin plated steel rectangular can	Heavy gauge welded steel construction	Heavy gauge welded steel construction	Heavy gauge welded steel construction	Extruded aluminum cylindrical can with M12 mounting stud	Extruded aluminum cylindrical can with M12 mounting stud
Finish	None (standard) Painted (optional)	Light gray paint, ANSI #61, UL approved for outdoor usage	Light gray paint, ANSI #61, UL approved for outdoor usage	Light gray paint, ANSI #61, UL approved for outdoor usage	None	None
Mounting	Optional bracketing is available	Heavy gauge brackets, mounting holes 2 x 1/2 x 5/8" slots	Heavy gauge brackets, mounting holes 2 x 1/2 x 5/8" slots	Heavy gauge brackets, mounting holes 2 x 1/2 x 5/8" slots	M12 mounting stud 10 NM max. torque	M12 mounting stud 10 NM max. torque
Terminals	3- and 2-terminal cover: 1/4"-20 male threaded stud, 20 in-lbs fastening torque	1/2"-13 brass studs, 160 in-lbs fastening torque, 30 kV BIL bushing	1/2"-13 brass studs, 160 in-lbs fastening torque, 30 kV BIL bushing	1/2"-13 brass studs, 160 in-lbs fastening torque, 60 kV BIL ceramic bushings	M6 terminal 2-1/2 NM fastening torque, M8 terminal 4 NM fastening torque	3-phase terminal with electrical shock protection (finger proof)
Loss of KVAR feature	-	Optional	Optional	-	-	-

AeroPower™ Power Factor Correction Capacitors

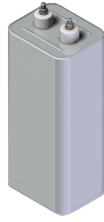
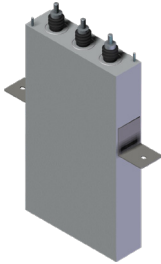
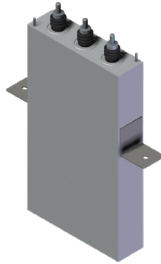
SINGLE-PHASE AND THREE-PHASE PFC CAPACITORS FOR HIGH RELIABILITY APPLICATIONS

Reactive Power Compensation Capacitor Specifications (cont.)

	AMPO Low Voltage (Three-phase and single-phase) (up to 600 VAC)	MMP0 Low Voltage (Three-phase and single-phase) (up to 600 VAC)	MMP0 Low Voltage (Three-phase and single-phase) (750 to 900 VAC)	MMP0 Medium Voltage (Three-phase and single-phase) (1040 to 4800 VAC)	EPFC Low Voltage (Three-phase) (up to 600 VAC) (60 Hz)	EPFC Low Voltage (Three-phase) (up to 525 VAC) (50 Hz)
						

Environmental Characteristics

Operating Temperature	-40°C to +46°C, -40°F to +115°F, with natural convection cooling	-40°C to +46°C, -40°F to +115°F, with natural convection cooling	-40°C to +46°C, -40°F to +115°F, with natural convection cooling	40°C to +46°C, -40°F to +115°F, with natural convection cooling	-40°C to +46°C, -40°F to +115°F, with natural convection cooling	-40°C to +55°C, -40°F to +131°F, with natural convection cooling
Storage Temperature	-40°C to +85°C, -40°F to +185°F	-40°C to +85°C, -40°F to +185°F	-40°C to +85°C, -40°F to +185°F	-40°C to +85°C, -40°F to +185°F	-40°C to +85°C, -40°F to +185°F	-40°C to +85°C, -40°F to +185°F
Maximum Altitude	2000 meters above sea level	2000 meters above sea level	2000 meters above sea level	2000 meters above sea level	2000 meters above sea level	4000 meters above sea level
Humidity	0 to 95% non-condensing	0 to 95% non-condensing	0 to 95% non-condensing	0 to 95% non-condensing	0 to 95% non-condensing	0 to 95% non-condensing
Standards	UL 810 UL C22.2 No. 190 Canadian Standards	UL 810 UL C22.2 No. 190 Canadian Standards ANSI/IEEE 18 NEMA CP-1	ANSI/IEEE 18 NEMA CP-1	ANSI/IEEE 18 NEMA IEC 871-1	UL 810 IEC 60831	IS 5553 IEC 60289
Certifications	UL Recognized CYTW2 cUL Recognized CYTW8 RoHS Compliant	UL Recognized CYTW2 cUL Recognized CYTW8	-	-	UL Recognized CYTW2 cUL Recognized CYTW8	CE
Safety Features	Pressure interrupter Self-healing technology External discharge resistors	Pressure interrupter Self-healing technology Internal discharge resistors	Pressure interrupter Self-healing technology Internal discharge resistors	Self-healing technology Internal discharge resistors	Pressure interrupter Self-healing technology Internal discharge resistors	Pressure interrupter Self-healing technology Internal discharge resistors

AeroPower™ Power Factor Correction Capacitors

SINGLE-PHASE AND THREE-PHASE PFC CAPACITORS FOR HIGH RELIABILITY APPLICATIONS

Safety Features

Discharge resistors are placed internally on MMP0 and EPFC and externally on AMP0 capacitor cells. The resistors are a safety feature that drains the voltage on the capacitor once the unit is taken offline to less than 50 volts in one minute or less for cells rated up to 600 VAC or in 5 minutes or less for cells rated over 600 VAC. The resistors are sized for long life continuous operation at maximum-rated temperature.

CD-Aero low-voltage capacitor cells have UL and cUL recognized pressure-sensitive circuit interrupters. The circuit interrupter's purpose is to safely remove the capacitor from service at end-of-life or under heavy fault conditions and still maintain case integrity. CD-Aero low-voltage capacitor cells are listed for use with or without fuses at 10,000 amps available fault current (AFC rating).

Self-healing technology: in case of an overload, the self-healing properties of the low-loss metallized polypropylene will prevent permanent dielectric breakdown.

Mounting Orientation

All CD-Aero power factor correction capacitors can be mounted in a vertical position with the terminals facing up or horizontally. The units should not be mounted upside down. For proper operation of the pressure interrupter, capacitors mounted in banks must have enough space between them for expansion. In cases where brackets or mounting straps are used, there should only be enough pressure on the unit to hold it in place.

Suggested Mounting Clearances

	Side to Side Clearance	Clearance above Terminals
AMP0/EPFC	0.5"	1.0"
MMP0-LV	1.5"	1.0"
MMP0-MV	1.5"	3.0"

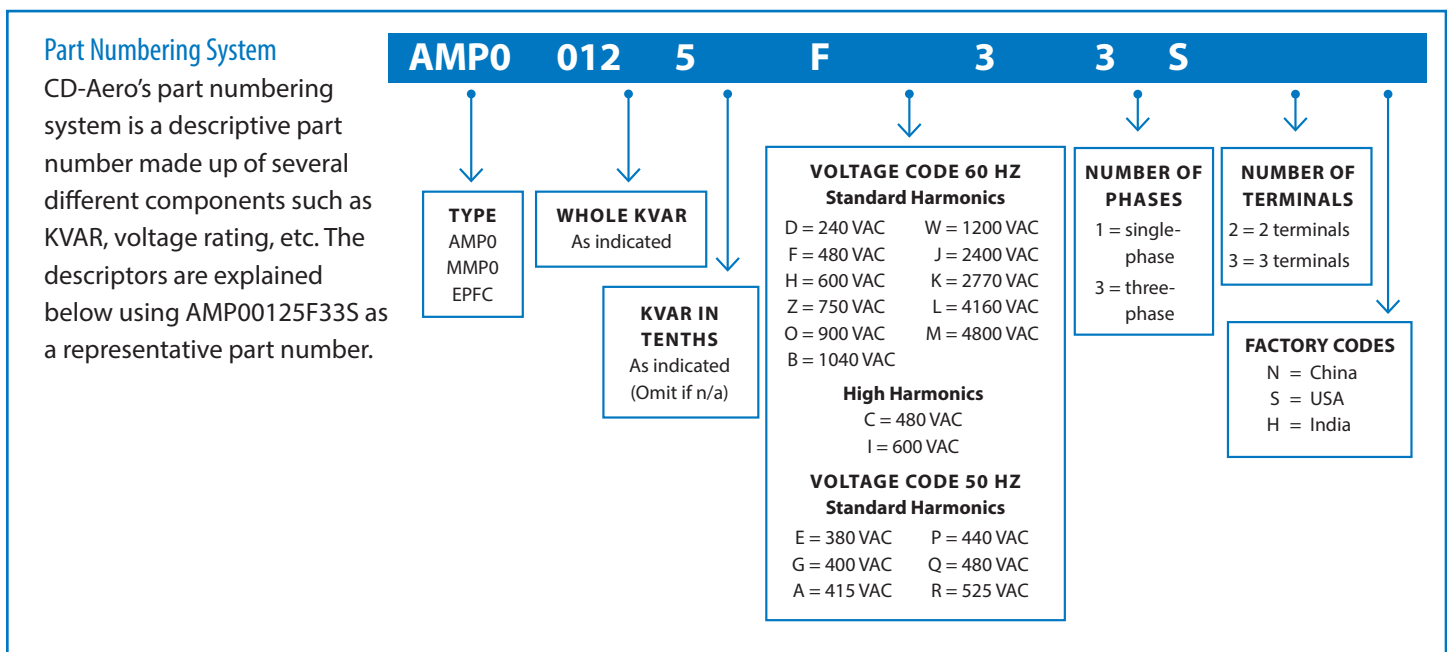

AeroPower™ Power Factor Correction Capacitors

SINGLE-PHASE AND THREE-PHASE PFC CAPACITORS FOR HIGH RELIABILITY APPLICATIONS

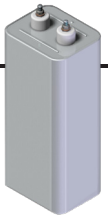

Type AMP0 Capacitor Cells, 240 to 600 VAC, Three-Phase and Single-Phase

Reactive Power Compensation Ratings

KVAR RATING	CD-AERO P/N	NOMINAL CURRENT (A _{RMS})	C, NOMINAL CAPACITANCE (μF)	CAN SIZE W x L x H (in)	APPROX WEIGHT (lbs)
-------------	-------------	-------------------------------------	-----------------------------	-------------------------	---------------------

240 VAC, 60 Hz, 3-Phase, Delta Connection

2.5	AMP00025D33S	6	115.1	3.75 x 4.56 x 5	3.7
5	AMP0005D33S	12	230.3	3.75 x 4.56 x 6	4.5
6	AMP0006D33S	14.4	276.3	3.75 x 4.56 x 6.38	4.7
7.5	AMP00075D33S	18	345.4	3.75 x 4.56 x 7	5.2
10	AMP0010D33S	24.1	460.4	3.75 x 4.56 x 7	5.2
12.5	AMP00125D33S	30.1	575.6	3.75 x 4.56 x 9	6.7

480 VAC, 60 Hz, 3-Phase, Delta Connection

2.5	AMP00025F33S	3	28.8	3.75 x 4.56 x 5	3.7
5	AMP0005F33S	6	57.6	3.75 x 4.56 x 5	3.7
7.5	AMP00075F33S	9	86.3	3.75 x 4.56 x 6	4.5
10	AMP0010F33S	12	115.1	3.75 x 4.56 x 6.38	4.7
12.5	AMP00125F33S	15	143.9	3.75 x 4.56 x 6.38	4.7
15	AMP0015F33S	18	172.7	3.75 x 4.56 x 7	5.2
16.7	AMP00167F33S	20.1	191.9	3.75 x 4.56 x 7	5.2
17.5	AMP00175F33S	21	201.5	3.75 x 4.56 x 7	5.2
20	AMP0020F33S	24.1	230.3	3.75 x 4.56 x 7	5.2
22.5	AMP00225F33S	27.1	259	3.75 x 4.56 x 9	6.7
25	AMP0025F33S	30.1	287.8	3.75 x 4.56 x 9	6.7

480 VAC, High Harmonic Applications, 3-Phase, Delta Connection

7.5	AMP00075C33S	9	86.3	3.75 x 4.56 x 6.38	4.7
10	AMP0010C33S	12	115.1	3.75 x 4.56 x 6	4.5
12.5	AMP00125C33S	15	143.9	3.75 x 4.56 x 7	5.2
15	AMP0015C33S	18	172.7	3.75 x 4.56 x 10.5	7.8
16.7	AMP00167C33S	20.1	191.9	3.75 x 4.56 x 10.5	7.8
17.5	AMP00175C33S	21.1	201.5	3.75 x 4.56 x 10.5	7.8
20	AMP0020C33S	24.1	230.3	3.75 x 4.56 x 10.5	7.8

Custom ratings and sizes available. Please contact CD-Aero.

AeroPower™ Power Factor Correction Capacitors

SINGLE-PHASE AND THREE-PHASE PFC CAPACITORS FOR HIGH RELIABILITY APPLICATIONS

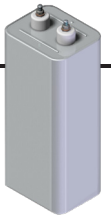

Type AMP0 Capacitor Cells, 240 to 600 VAC, Three-Phase and Single-Phase (cont.)

Reactive Power Compensation Ratings

KVAR RATING	CD-AERO P/N	NOMINAL CURRENT (A_{RMS})	C, NOMINAL CAPACITANCE (μF)	CAN SIZE W x L x H (in)	APPROX WEIGHT (lbs)
-------------	-------------	-------------------------------	------------------------------------	-------------------------	---------------------

600 VAC, 60 Hz, 3-Phase, Delta Connection

2.5	AMP00025H33S	2.4	18.4	3.75 x 4.56 x 5	3.7
5	AMP0005H33S	4.8	36.8	3.75 x 4.56 x 5	3.7
7.5	AMP00075H33S	7.2	55.3	3.75 x 4.56 x 6	4.5
10	AMP0010H33S	9.6	73.7	3.75 x 4.56 x 6	4.5
12.5	AMP00125H33S	12	92.1	3.75 x 4.56 x 6	4.5
15	AMP0015H33S	14.4	110.5	3.75 x 4.56 x 6	4.5
16.7	AMP00167H33S	16.1	123.1	3.75 x 4.56 x 6	4.5
17.5	AMP00175H33S	16.8	128.9	3.75 x 4.56 x 6	4.5
20	AMP0020H33S	19.2	147.4	3.75 x 4.56 x 7	5.2
22.5	AMP00225H33S	21.7	165.8	3.75 x 4.56 x 8.63	6.4
25	AMP0025H33S	24.1	184.2	3.75 x 4.56 x 9	6.7

600 VAC, High Harmonic Applications, 3-Phase, Delta Connection

10	AMP0010I33S	9.6	73.7	3.75 x 4.56 x 6	4.5
12.5	AMP00125I33S	12	92.1	3.75 x 4.56 x 8.25	6.2
15	AMP0015I33S	14.4	110.5	3.75 x 4.56 x 9	6.7
16.7	AMP00167I33S	16.1	123.1	3.75 x 4.56 x 9	6.7
17.5	AMP00175I33S	16.8	128.9	3.75 x 4.56 x 10.5	7.8
20	AMP0020I33S	19.2	147.4	3.75 x 4.56 x 10.5	7.8

Outline Drawings

AMP0: Suffix "33S"

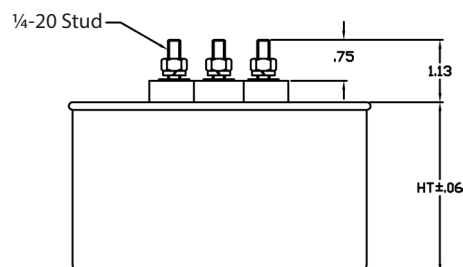
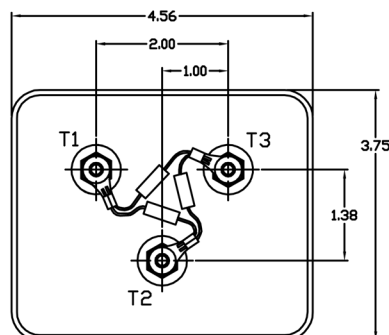

167 John Vertente Blvd.
New Bedford, MA 02745

Tel: +1-508-910-3500
Fax: +1-508-995-3000

sales1@Aerovox.com
www.CD-Aero.com

AeroPower™ Power Factor Correction Capacitors

**SINGLE-PHASE AND THREE-PHASE PFC CAPACITORS
FOR HIGH RELIABILITY APPLICATIONS**

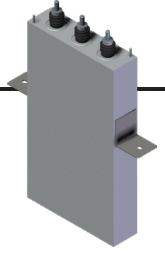

Type MMPO Capacitor Cells, 240 to 600 VAC, Three-Phase and Single-Phase

Reactive Power Compensation Ratings

KVAR RATING	CD-AERO P/N	NOMINAL CURRENT (A _{RMS})	C, NOMINAL CAPACITANCE (μF)	CAN SIZE W x L x H (in)	APPROX WEIGHT (lbs)
-------------	-------------	-------------------------------------	-----------------------------	-------------------------	---------------------

240 VAC, 60 Hz, 3-Phase, Delta Connection

25	MMP0025D33	60.1	1151.3	3.75 x 13.5 x 13.5	31.3
30	MMP0030D33	72.2	1381.6	3.75 x 13.5 x 15.5	36.5

480 VAC, 60 Hz, 3-Phase, Delta Connection

25	MMP0025F33	30.1	287.8	3.75 x 13.5 x 8.5	21.4
30	MMP0030F33	36.1	345.4	3.75 x 13.5 x 9.5	23.5
35	MMP0035F33	42.1	403	3.75 x 13.5 x 11.5	28.1
40	MMP0040F33	48.1	460.5	3.75 x 13.5 x 11.5	28.3
50	MMP0050F33	60.1	575.6	3.75 x 13.5 x 13.5	32.3
60	MMP0060F33	72.2	690.8	3.75 x 13.5 x 15.5	36.4
75	MMP0075F33	90.2	863.5	3.75 x 13.5 x 18.5	43.1
80	MMP0080F33	96.2	921	3.75 x 13.5 x 19.5	44.6
90	MMP0090F33	108.3	1036.2	3.75 x 13.5 x 20.5	45.9
100	MMP0100F33	120.3	1151.3	3.75 x 13.5 x 24	55.3

480 VAC, High Harmonic Applications, 3-Phase, Delta Connection

25	MMP0025C33	30.1	287.8	3.75 x 13.5 x 8.5	21.4
50	MMP0050C33	60.1	575.6	3.75 x 13.5 x 13.5	32.3
75	MMP0075C33	90.2	863.5	3.75 x 13.5 x 18.5	43.1
100	MMP0100C33	120.3	1151.3	3.75 x 13.5 x 24	55.3

600 VAC, High Harmonic Applications, 3-Phase, Delta Connection

25	MMP0025I33	24.1	184.2	3.75 x 13.5 x 8.5	21.4
30	MMP0030I33	28.9	221	3.75 x 13.5 x 9.5	23.5
35	MMP0035I33	33.7	275.9	3.75 x 13.5 x 11.5	28.1
40	MMP0040I33	38.5	294.7	3.75 x 13.5 x 11.5	28.3
45	MMP0045I33	43.3	331.6	3.75 x 13.5 x 13.5	32.2
50	MMP0050I33	48.1	368.4	3.75 x 13.5 x 13.5	32.3
60	MMP0060I33	57.7	442.1	3.75 x 13.5 x 15.5	36.4
75	MMP0075I33	72.2	552.6	3.75 x 13.5 x 18.5	43.1
80	MMP0080I33	77	589.5	3.75 x 13.5 x 19.5	44.6
90	MMP0090I33	86.6	663.1	3.75 x 13.5 x 20.5	45.9
100	MMP0100I33	96.2	736.8	3.75 x 13.5 x 24	55.3

Custom ratings and sizes available. Please contact CD-Aero.

AeroPower™ Power Factor Correction Capacitors

SINGLE-PHASE AND THREE-PHASE PFC CAPACITORS FOR HIGH RELIABILITY APPLICATIONS

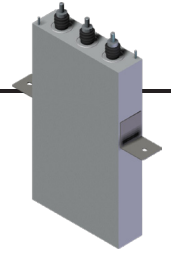

Type MMPO Capacitor Cells, 750 VAC and 900 VAC, Three-Phase and Single-Phase

Reactive Power Compensation Ratings

KVAR RATING	CD-AERO P/N	NOMINAL CURRENT (A _{RMS})	C, NOMINAL CAPACITANCE (μF)	CAN SIZE W x L x H (in)	APPROX WEIGHT (lbs)
750 VAC, 60 Hz, 3-Phase, "WYE" Connection					
100	MMP0100Z33	77	1414.7	3.75 x 13.5 x 24	55.3
900 VAC, 60 Hz, 3-Phase, "WYE" Connection					
100	MMP0100O33	64.2	982.4	3.75 x 13.5 x 20.5	49.6

Type MMPO Capacitor Cells, 1040 VAC to 4800 VAC, Three-Phase and Single-Phase

Reactive Power Compensation Ratings

KVAR RATING	CD-AERO P/N	NOMINAL CURRENT (A _{RMS})	C, NOMINAL CAPACITANCE (μF)	CAN SIZE W x L x H (in)	APPROX WEIGHT (lbs)
1040 VAC, 60 Hz, 3-Phase, Delta Connection					
25	MMP0025B33	13.9	61.3	5.63 x 13.5 x 6	20.5
75	MMP0075B33	41.6	183.9	5.63 x 13.5 x 10	34.2
100	MMP0100B33	55.6	245.2	5.63 x 13.5 x 11.5	39.3
125	MMP0125B33	69.4	306.6	5.63 x 13.5 x 13	44.5
150	MMP0150B33	83.3	367.9	5.63 x 13.5 x 15	51.3
175	MMP0175B33	97.2	429.2	5.63 x 13.5 x 17.5	59.9
200	MMP0200B33	111	490.5	5.63 x 13.5 x 20	68.4
1200 VAC, 60 Hz, 3-Phase, Delta Connection					
25	MMP0025W33	12	46.1	5.63 x 13.5 x 6	20.5
50	MMP0050W33	24.1	92.1	5.63 x 13.5 x 9	30.8
100	MMP0100W33	48.1	184.2	5.63 x 13.5 x 11.5	39.3
125	MMP0125W33	60.1	230.3	5.63 x 13.5 x 14	47.9
150	MMP0150W33	72.2	276.3	5.63 x 13.5 x 15	51.3
175	MMP0175W33	84.2	322.4	5.63 x 13.5 x 17.5	59.9
200	MMP0200W33	96.2	368.4	5.63 x 13.5 x 19	65
2400 VAC, 60 Hz, 3-Phase, Delta Connection					
25	MMP0025J33	6	11.5	5.63 x 13.5 x 6	20.5
50	MMP0050J33	12	23	5.63 x 13.5 x 7.5	25.7
75	MMP0075J33	18	34.5	5.63 x 13.5 x 10	34.2
100	MMP0100J33	24.1	46.1	5.63 x 13.5 x 11.5	39.3
125	MMP0125J33	30.1	57.6	5.63 x 13.5 x 14	47.9
150	MMP0150J33	36.1	69.1	5.63 x 13.5 x 16	54.7
175	MMP0175J33	42.1	80.6	5.63 x 13.5 x 17.5	59.9
200	MMP0200J33	48.1	92.1	5.63 x 13.5 x 19	65

Custom ratings and sizes available. Please contact CD-Aero.

AeroPower™ Power Factor Correction Capacitors

SINGLE-PHASE AND THREE-PHASE PFC CAPACITORS FOR HIGH RELIABILITY APPLICATIONS

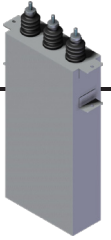

Type MMPO Capacitor Cells, 1040 VAC to 4800 VAC, Three-Phase and Single-Phase (cont.)

Reactive Power Compensation Ratings

KVAR RATING	CD-AERO P/N	NOMINAL CURRENT (A _{RMS})	C, NOMINAL CAPACITANCE (μF)	CAN SIZE W x L x H (in)	APPROX WEIGHT (lbs)
25	MMP0025K33	5.2	8.6	5.63 x 13.5 x 7.5	25.7
50	MMP0050K33	10.4	17.3	5.63 x 13.5 x 9	30.8
75	MMP0075K33	15.6	25.9	5.63 x 13.5 x 11.5	39.3
100	MMP0100K33	20.8	34.6	5.63 x 13.5 x 15	47
125	MMP0125K33	26.1	73.2	5.63 x 13.5 x 16	54.7
150	MMP0150K33	31.3	51.9	5.63 x 13.5 x 17.5	59.9
175	MMP0175K33	36.5	60.5	5.63 x 13.5 x 19	65
200	MMP0200K33	41.7	69.1	5.63 x 13.5 x 20	68.4
4160 VAC, 60 Hz, 3-Phase, Delta Connection					
25	MMP0025L33	3.5	3.8	5.63 x 13.5 x 7.5	25.7
50	MMP0050L33	7	7.7	5.63 x 13.5 x 9	30.8
75	MMP0075L33	10.4	11.5	5.63 x 13.5 x 11.5	39.3
100	MMP0100L33	13.9	15.3	5.63 x 13.5 x 11.5	39.3
125	MMP0125L33	17.4	19.2	5.63 x 13.5 x 16	54.7
150	MMP0150L33	20.8	23	5.63 x 13.5 x 17.5	59.9
175	MMP0175L33	24.3	26.8	5.63 x 13.5 x 19	65
200	MMP0200L33	27.8	30.7	5.63 x 13.5 x 20	68.4
4800 VAC, 60 Hz, 3-Phase, Delta Connection					
25	MMP0025M33	3	2.9	5.63 x 13.5 x 7.5	25.7
50	MMP0050M33	6	4.8	5.63 x 13.5 x 9	30.8
75	MMP0075M33	9	8.6	5.63 x 13.5 x 10	34.2
100	MMP0100M33	12	11.5	5.63 x 13.5 x 11.5	39.3
125	MMP0125M33	15	14.4	5.63 x 13.5 x 16	54.7
150	MMP0150M33	18	17.3	5.63 x 13.5 x 17.5	59.9
175	MMP0175M33	21.1	20.1	5.63 x 13.5 x 17.5	59.9
200	MMP0200M33	24.1	23	5.63 x 13.5 x 20	68.4

AeroPower™ Power Factor Correction Capacitors

SINGLE-PHASE AND THREE-PHASE PFC CAPACITORS FOR HIGH RELIABILITY APPLICATIONS

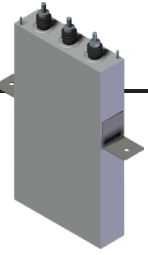

Outline Drawings

MMP0: 240, 480, 600, 750 & 900 VAC

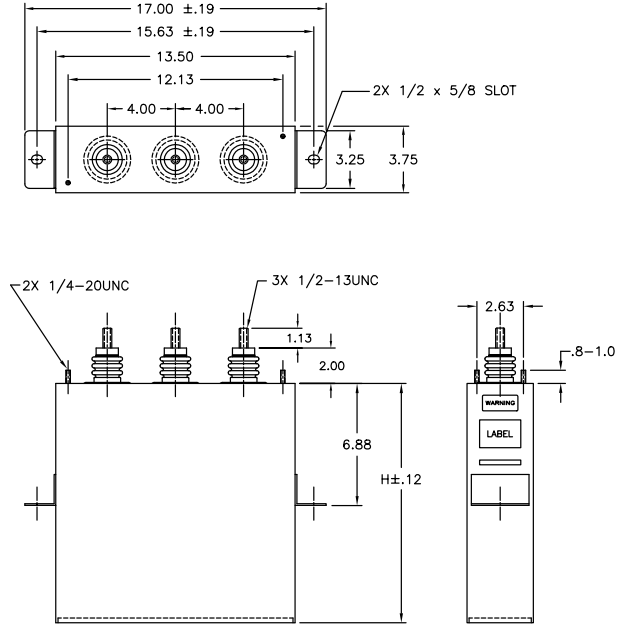

MMP0: 1040 to 4800 VAC

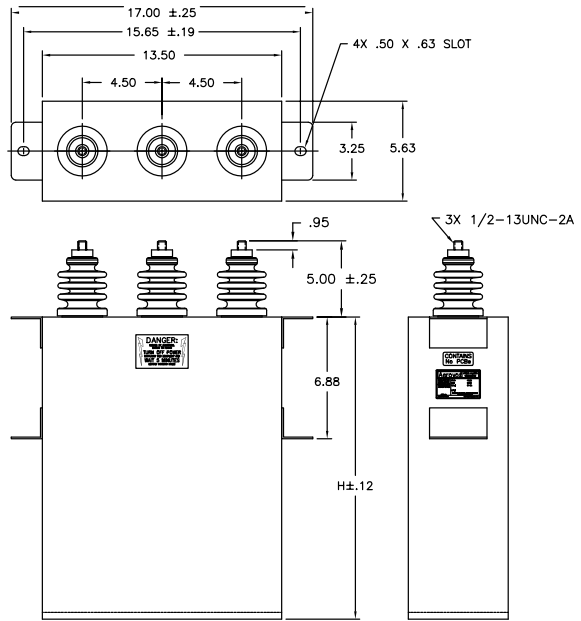

AeroPower™ Power Factor Correction Capacitors

SINGLE-PHASE AND THREE-PHASE PFC CAPACITORS FOR HIGH RELIABILITY APPLICATIONS



Type EPFC Capacitor Cells*

KVAR RATING	CD-AERO P/N	NOMINAL CURRENT (A _{RMS})	C, NOMINAL CAPACITANCE (μF)	DIMENSIONS D x H (mm)	APPROX WEIGHT (kg)
-------------	-------------	-------------------------------------	-----------------------------	-----------------------	--------------------

240 VAC, 60 Hz, 3-Phase, Delta Connection

0.5	EPFC0005D33N	1.2	23	76 x 70	0.48
1	EPFC001D33N	2.4	46.1	76 x 76	0.5
2	EPFC002D33N	4.8	92.1	76 x 140	0.78
2.5	EPFC0025D33N	6	115.1	76 x 140	0.78
3	EPFC003D33N	7.2	138.2	76 x 140	0.78
4	EPFC004D33N	9.6	184.2	86 x 115	0.9
5	EPFC005D33N	12	230.3	86 x 170	1.2
6	EPFC006D33N	14.4	276.3	86 x 170	1.2
7.5	EPFC0075D33N	18	345.4	86 x 170	1.2
10	EPFC010D33N	24.1	460.4	86 x 200	1.35

480 VAC, 60 Hz, 3-Phase, Delta Connection

2	EPFC002F33N	2.4	23	86 x 70	0.6
7.5	EPFC0075F33N	9	86.3	86 x 170	1.15
10	EPFC010F33N	12	115.1	86 x 170	1.15
12.5	EPFC0125F33N	15	143.9	86 x 170	1.15
15	EPFC015F33N	18	172.7	86 x 200	1.35
16.7	EPFC0167F33N	20	191.9	86 x 215	1.45
17.5	EPFC0175F33N	21	201.8	86 x 245	1.6
20	EPFC020F33N	24	230.3	86 x 245	1.6
22.5	EPFC0225F33N	27	259	86 x 275	1.75
25	EPFC025F33N	30	287.8	86 x 275	1.75
30	EPFC030F33N	36	345.6	116 x 285	3.15
35	EPFC035F33N	42.1	403.2	116 x 315	3.45
40	EPFC040F33N	48.1	460.8	116 x 342	3.7

480 VAC, 60 Hz, High Harmonic Applications, 3-Phase, Delta Connection

12.5	EPFC0125C33N	15	143.9	86 x 245	1.6
15	EPFC015C33N	18	172.7	86 x 275	1.75
16.7	EPFC0167C33N	20	191.9	86 x 305	1.9
17.5	EPFC0175C33N	21	201.5	86 x 305	1.9
20	EPFC020C33N	24	230.3	86 x 335	2.05

600 VAC, 60 Hz, 3-Phase, Delta Connection

Custom ratings and sizes available. Please contact CD-Aero.

AeroPower™ Power Factor Correction Capacitors

SINGLE-PHASE AND THREE-PHASE PFC CAPACITORS FOR HIGH RELIABILITY APPLICATIONS



Type EPFC Capacitor Cells

KVAR RATING	CD-AERO P/N	NOMINAL CURRENT (A _{RMS})	C, NOMINAL CAPACITANCE (μF)	DIMENSIONS D x H (mm)	APPROX WEIGHT (kg)
10	EPFC010H33N	9.6	73.7	86 x 170	1.15
12.5	EPFC0125H33N	12	92.1	86 x 170	1.15
15	EPFC015H33N	14.4	110.5	86 x 200	1.35
16.7	EPFC0167H33N	16	122.8	86 x 215	1.45
17.5	EPFC0175H33N	16.8	128.9	86 x 215	1.45
20	EPFC020H33N	19.2	147.4	86 x 245	1.6
22.5	EPFC0225H33N	21.6	165.8	86 x 275	1.75
25	EPFC025H33N	24	184.2	86 x 275	1.75
30	EPFC030H33N	28.8	219.9	116 x 285	2.95
35	EPFC035H33N	33.6	258	116 x 315	3.25
40	EPFC040H33N	38.4	294.9	116 x 342	3.7

600 VAC, 60 Hz, High Harmonic Applications, 3-Phase, Delta Connection

10	EPFC010I33N	9.6	73.7	86 x 200	1.35
12.5	EPFC0125I33N	12	92.1	86 x 245	1.6
15	EPFC015I33N	14.4	110.5	86 x 245	1.6
16.7	EPFC0167I33N	16	122.8	86 x 275	1.75
17.5	EPFC0175I33N	16.8	128.9	86 x 275	1.75
20	EPFC020I33N	19.2	147.4	86 x 305	1.9
25	EPFC025I33N	24.1	184.4	116 x 315	3.5

*Made in China

AeroPower™ Power Factor Correction Capacitors

**SINGLE-PHASE AND THREE-PHASE PFC CAPACITORS
FOR HIGH RELIABILITY APPLICATIONS**



Outline Drawings

EPFC: 240 to 600 VAC

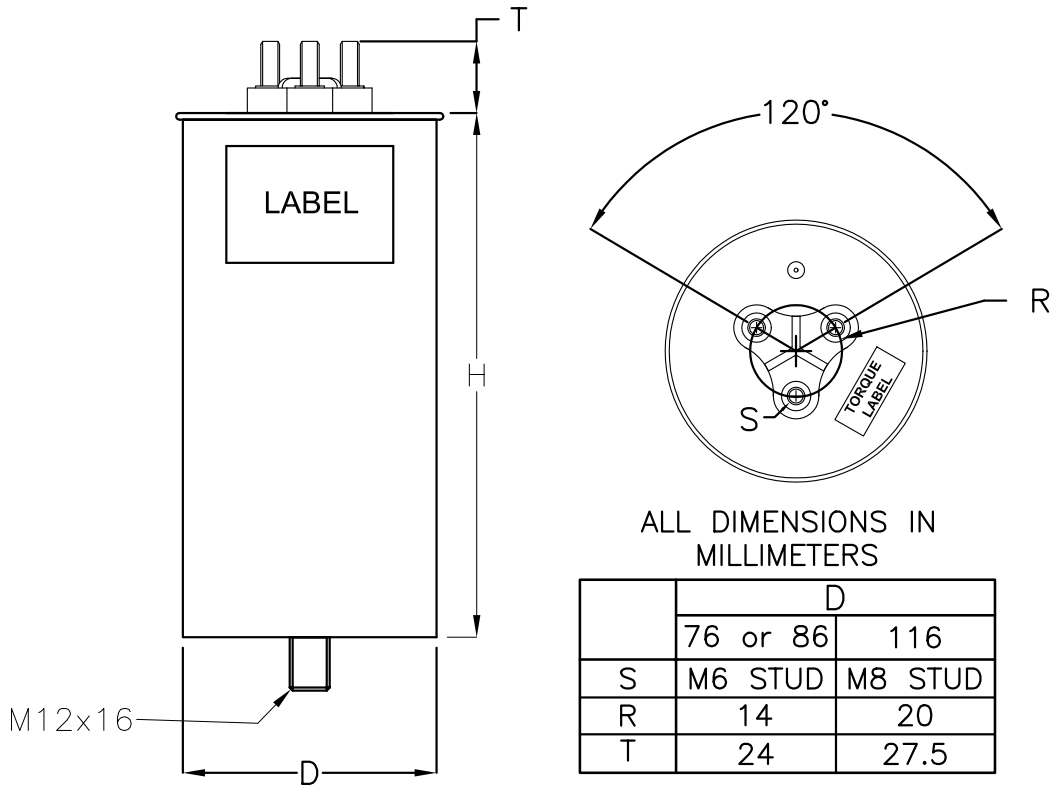

AeroPower™ Power Factor Correction Capacitors

SINGLE-PHASE AND THREE-PHASE PFC CAPACITORS FOR HIGH RELIABILITY APPLICATIONS

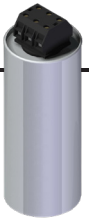

CD-Aero 50 Hz EPFC*

KVAR RATING	CD-AERO P/N	NOMINAL CURRENT (A _{RMS})	C _t NOMINAL CAPACITANCE (μF)	CAN SIZE D x H (mm)	APPROX WEIGHT (kg)
-------------	-------------	-------------------------------------	---	---------------------	--------------------

400 VAC, 50 Hz, 3-Phase Delta Connection

2	EPFC002G33H	2.88	39.8	75 x 175	0.91
2.5	EPFC0025G33H	3.6	49.7	75 x 175	0.91
5	EPFC005G33H	7.2	99.5	75 x 175	0.91
7.5	EPFC0075G33H	10.8	149.2	75 x 210	1.08
10	EPFC010G33H	14.4	198.9	85 x 210	1.45
12.5	EPFC0125G33H	18	248.7	95 x 210	1.36
15	EPFC015G33H	21.6	298.4	95 x 210	1.36
20	EPFC020G33H	28.9	397.9	95 x 247	1.93
25	EPFC025G33H	36.1	497.4	116 x 247	2.81
30	EPFC030G33H	43.3	596.8	116 x 247	2.81
50	EPFC050G33H	72.2	994.7	116 x 353	3

415 VAC, 50 Hz, 3-Phase Delta Connection

2	EPFC002A33H	2.8	37	75 x 175	0.91
5	EPFC005A33H	7	92.4	75 x 175	0.91
7.5	EPFC0075A33H	10.4	138.6	75 x 210	1.08
10	EPFC010A33H	13.9	184.8	75 x 210	1.08
12.5	EPFC0125A33H	17.4	231	85 x 210	1.45
15	EPFC015A33H	20.9	277.2	95 x 210	1.36
20	EPFC020A33H	27.8	369.6	95 x 247	1.93
25	EPFC025A33H	34.8	462.1	116 x 247	2.81
30	EPFC030A33H	41.7	554.5	116 x 247	2.81
50	EPFC050A33H	69.6	924.1	116 x 353	3

440 VAC, 50 Hz, 3-Phase Delta Connection

2	EPFC002P33H	2.6	32.9	75 x 175	0.91
2.5	EPFC0025P33H	3.3	41.1	75 x 175	0.91
5	EPFC005P33H	6.6	82.2	75 x 175	0.91
7.5	EPFC0075P33H	9.8	123.3	75 x 175	0.91
10	EPFC010P33H	13.1	164.4	75 x 210	1.1
12.5	EPFC0125P33H	16.4	205.5	85 x 210	1.16
15	EPFC015P33H	19.7	246.6	95 x 210	1.36
20	EPFC020P33H	26.2	328.8	95 x 247	1.93
25	EPFC030P33H	32.8	411	116 x 210	2.4
30	EPFC030P33H	39.4	493.2	116 x 247	2.81
50	EPFC050P33H	65.6	822.1	116 x 353	3

480 VAC, 50 Hz, 3-Phase Delta Connection

Custom ratings and sizes available. Please contact CD-Aero.

AeroPower™ Power Factor Correction Capacitors

SINGLE-PHASE AND THREE-PHASE PFC CAPACITORS FOR HIGH RELIABILITY APPLICATIONS

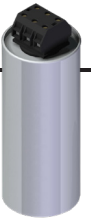

KVAR RATING	CD-AERO P/N	NOMINAL CURRENT (A _{RMS})	C _i NOMINAL CAPACITANCE (μF)	CAN SIZE D x H (mm)	APPROX WEIGHT (kg)
5	EPFC005Q33H	6	69.1	75 x 175	0.94
7.5	EPFC0075Q33H	9	103.6	75 x 210	1.08
10	EPFC010Q33H	12	138.2	85 x 210	1.41
12.5	EPFC0125Q33H	15	172.7	95 x 210	1.36
15	EPFC015Q33H	18	207.2	95 x 247	1.93
20	EPFC020Q33H	24.1	276.3	95 x 247	1.93
25	EPFC025Q33H	30.1	345.4	116 x 247	2.81

525 VAC, 50 Hz, 3-Phase Delta Connection

5	EPFC005R33H	5.5	57.7	75 x 175	0.96
7.5	EPFC0075R33H	8.2	86.6	75 x 210	1.11
10	EPFC010R33H	11	115.5	95 x 210	1.36
12.5	EPFC0125R33H	13.8	144.4	95 x 247	1.93
15	EPFC015R33H	16.5	173.2	95 x 247	1.93
20	EPFC020R33H	22	231	116 x 247	2.81
25	EPFC025R33H	27.5	288.7	136 x 247	2.99

*Made in India

Outline Drawings

EPFC: 400 to 525 VAC

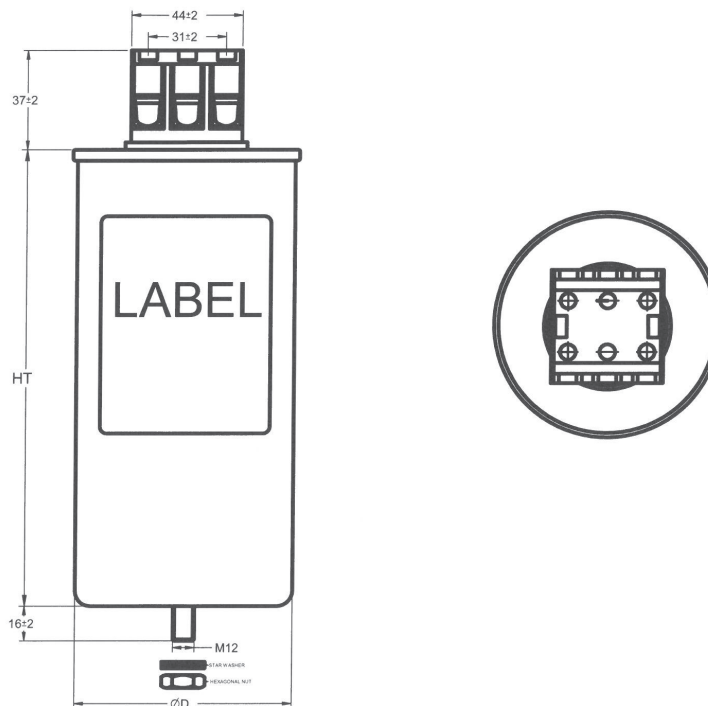

Different terminal options available upon request.

167 John Vertente Blvd.
New Bedford, MA 02745

Tel: +1-508-910-3500
Fax: +1-508-995-3000

sales1@Aerovox.com
www.CD-Aero.com

Equations for Power Factor Correction and Harmonic Distortion (Balanced Phase Loads)

Capacitors in Parallel

$$C_T = C_1 + C_2 + C_3 + \dots + C_n = \sum_{i=1}^n C_i$$

Capacitors in Series

$$\frac{1}{C_T} = \frac{1}{C_1} + \frac{1}{C_2} + \frac{1}{C_3} + \dots + \frac{1}{C_n} = \sum_{i=1}^n \frac{1}{C_i}$$

$$DF = \tan(\delta) = \frac{ESR}{X_c} = (2\pi f)(C)(ESR)$$

$$\text{Power Loss} = (2\pi f)(C \times V^2)(DF)$$

$$X_c = \frac{1}{(2\pi f)C}$$

$$C_T = \frac{KVAR \times 10^{-3}}{(2\pi f)(KV)^2}$$

$$KW \text{ (Motor Input)} = \frac{hp \times 0.746}{\%Eff}$$

$$KVA = \frac{KW}{PF} = \sqrt{(KW)^2 + (KVAR)^2}$$

$$KVAR = \frac{2\pi \times f \times C \times (KV)^2}{10^{-3}}$$

$$KVAR_E = KVAR_R \times \left[\frac{V_A}{V_R} \right]^2 \times \left[\frac{f_A}{f_R} \right]$$

$$KVAR = \frac{hp \times 0.746}{\eta} \left[\sqrt{\frac{1 - PF_0^2}{PF_0^2}} - \sqrt{\frac{1 - PF_T^2}{PF_T^2}} \right]$$

$$KVA = \frac{V_L \times I_L}{1000} \quad \text{Single-Phase}$$

$$KVA = \frac{\sqrt{3} \times V_L \times I_L}{1000} \quad \text{Three-Phase}$$

$$I_{RMS} = \sqrt{I_1^2 + \sum_{h=2}^{\infty} I_h^2}$$

AeroPower™ Power Factor Correction Capacitors

SINGLE-PHASE AND THREE-PHASE PFC CAPACITORS FOR HIGH RELIABILITY APPLICATIONS

Legend

K	1000	V_A	Applied line Voltage
W	Watts	V_R	Rated line voltage
V	Volts	f_A	Applied frequency
A	Amperes	f_R	Rated frequency
hp	Horsepower	η	Motor efficiency
C	Capacitance (Farads)	PF_0	Initial Power Factor
PF	Power Factor	PF_T	Target Power Factor
KW	Working Power (1000 Watts)	I_{RMS}	Root-mean-square value of current
KVA	Total Power (1000 Volt-Amperes)	I_1	Current at fundamental frequency
KVAR	Reactive Power (1000 Volt-Amperes Reactive)	I_h	Harmonic current of order h
δ	Loss Angle	C_T	Total capacitance (Farads)
V_L	Line Voltage	X_c	Capacitor reactance
I_L	Line current	I_{ph}	Phase current
f	Frequency	DF	Dissipation Factor
$KVAR_E$	Effective KVAR	ESR	Equivalent Series Resistances (Ohms)
$KVAR_R$	Rated KVAR		
	KVAR De-rating for Voltage & Frequency		

Connection Types

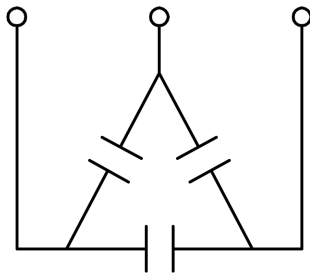

Delta Connection

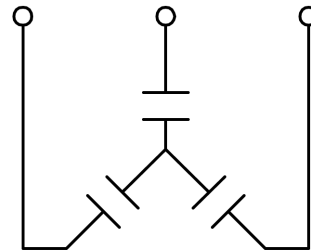

Wye Connection



Why Do You Need Power Factor Correction?

Power Factor Correction capacitors (PFCs) save power in an electric power system, and the savings can be substantial. PFCs do this by helping filter the harmonics load in the power system, which allows more efficient usage of utility power and reduces the amount of current lost. More useful power is transferred to the power system without requiring larger wiring or more robust equipment.

If a power system is receiving “dirty” power (fluctuations, harmonic dissonance, etc.) the PFC capacitor can filter these out and the capacitor will not fail. Use of PFC capacitors in industrial or manufacturing settings results in significant cost savings and longer equipment life. The efficient use of power also means the utility grid can avoid building additional power generators, saving capital cost, specifically in emerging markets.

How Does Power Factor Correction Work?

Electric power has two components:

- 1) Active power which produces work.
- 2) Reactive power, which is needed to generate the magnetic fields required for the operation of inductive electrical equipment, but performs no useful work.

Active (or “real”) power is measured in KW (1000 Watts)

Reactive power is measured in KVAR (1000 Volt-Amperes Reactive)

Total (or “apparent”) power is measured in KVA (1000 Volt-Amperes)

The ratio of working power to total power is called power factor.

$$PF = \frac{\text{Real Power (expressed in Watts)}}{\text{Apparent Power (expressed in VA)}}$$

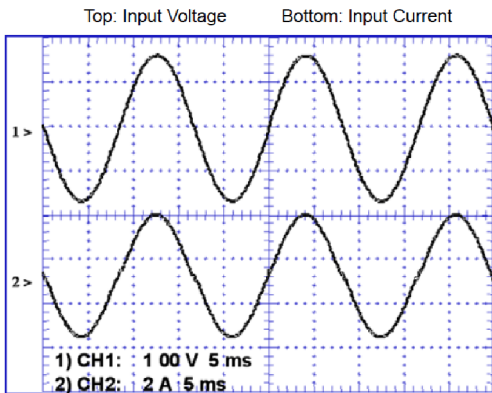

Power factor correction capacitors increase the power factor by supplying reactive power when installed at or near inductive electrical equipment. Ideally, the electrical load (motor, lights, etc.) should emulate a resistor, in which case, the reactive power is zero. The goal is to have a perfect sinewave of the current match the voltage.

Power Factor Correction Capacitors Save Money — So Keep Them Serviced!

Power factor correction capacitors lower electrical costs in two ways:

- 1) In many areas, the electrical rate includes a penalty charge when you have low power factor. Installing power factor capacitors on a facility's electrical distribution system makes it unnecessary for the utility to supply the reactive power which would otherwise be required by inductive electrical equipment. The savings the utility realizes in reduced generation, transmission, and distribution costs are passed onto the customer in the form of lower electrical bills.
- 2) The second source of savings realized by using power factor correction capacitors is in the form of increased KVA capacity in your electrical distribution system. Installing capacitors to furnish the non-productive current requirements of the facility makes it possible to increase the connected load as much as 20% without a corresponding increase in the size of the transformers, conductors, and protective devices in the distribution system which services the load.

What Can Go Wrong?

Without regular monitoring and maintenance of your PFC system, the system may not perform optimally, or worse, it may be headed for a breakdown. Issues can range from a non-ideal power factor to catastrophic failure of the entire PFC system. The capacitors and reactors could be severely damaged or destroyed. This could result in a full power down of the facility which will put your business lines down (\$\$\$\$). By maintaining the PFC system this can be avoided, and keep expensive replacement costs in check.

Safety Is Always First

Before working on any power factor system, make certain it is disconnected from the main power source, and that the output of the system is also disconnected. This ensures nothing is being fed backward through the system.

Also confirm the capacitors are discharged before disconnecting or adjusting any cabling or equipment. (PFC capacitors have discharge resistors to prevent shock, but manually checking that the capacitors did indeed discharge is always good practice.)

In the event testing needs to be completed while the PFC system is active, use extreme caution. Check that current transformers (CTs) are connected, as an open CT will create high voltage and could damage equipment as well as cause serious injury.

Where Should We Start?

Begin by performing a complete visual inspection of the system. This is a quick check to ensure the switches are working and the



capacitor banks are also working properly.

- Look for discolored components, bulging and/or leaking capacitors and signs of heating and/or moisture. Bulging in a capacitor is a telltale sign that it is at the end of its life.
- Check reactors for discolored cabling or cases.
- Check that fans are free of debris and in proper working order.
- Check the PFC controller and manually step through connecting each capacitor bank.
- Check the PFC % and ensure the phases are balanced.

Checking for Hot Spots

Thermal imaging is a great tool to evaluate an electrical system's performance. Imaging will need to be completed with the system running, so ensure you are following proper safety procedures first. Get your thermal imaging information where the wiring connections are to the capacitors and reactors - this includes the terminals of the capacitors.

- Check the capacitors for hot spots as well as the reactors. To do this, you will need to confirm the capacitors and reactors you are monitoring are live. There are usually manual settings from the PFC control to connect the components.
- Check specifically for temperature differences between phases of more than 7° C.
- Check that the spacing between capacitors is appropriate – 2 cm. minimum is usually standard. If there is forced air in your system, ensure the flow is appropriate and this is not causing heat transfer from one component to the next.
- If cabling or terminal heating is abnormal, ensure terminals are tightened to the appropriate torque, and that cables are not worn. Power down the system before adjusting.

Check Capacitance

Depending on the system, you will want to power down and make certain any three phase transformers are disconnected to ensure the proper measurement of the capacitor. Also, check that the capacitors are discharged before measuring capacitance. A charged capacitor can cause shock and/or damage to the equipment otherwise.

- Check the voltage across the capacitor phase-to-phase as well as phase-to-neutral. The voltage across the capacitors should be zero.
- Check the capacitance per the configuration Y, delta, and neutral connected. All phases of the capacitor should read within a single digit % of each other. A larger capacitance difference between phases is cause for further investigation.
- It is also good practice to measure the capacitance at more than one frequency.

Check Current

Checking current will need to be completed with a live system, so exercise caution.

- Using a current clamp CT, a best practice is to measure the current through the PFC system's current transformer and calculate the current on the line (this measurement can be used to validate the PFC panel).



- The CT ratio should be multiplied by the current measurement to calculate the current through the line/phase of the capacitor. The current measured will be the RMS (Root Mean Square) current through the capacitor (this current includes harmonics). Ensure the RMS current is acceptable for the capacitor rating and design.

Each current measurement on each phase should be within a single digit percentage of one another. Any phase imbalance will require deeper investigation.

- If the CT current is in question (measurement is high or low), measuring the line current for each phase into the capacitor would be the next step. As the current is much higher in the line than on the PFC system's current transformer, ensure the current clamp and meters are configured so as to measure the higher current.

Check Voltage

A check of the voltage will also need to be completed with a live system (use caution).

- Check the RMS voltage for each phase measuring from phase-to-phase and also phase-to-neutral.
- Check that your voltage measurements comply with the capacitor design limits. Each phase should be within a single percent of one another. Any phase imbalance will require further investigation.

Take a Deeper Dive — Harmonics and Transients

Checking voltage will also need to be completed with a live system (use caution). If the RMS measurements were within specifications, a study of the current and voltage harmonics would be a good idea. This will help you to understand power fluctuations due to transient loads from variable speed drives and any other nonlinear loads. Checking for systems tuned to harmonics is also a best practice when troubleshooting a faulty PFC system.

In Conclusion, Continued, Regular Maintenance

Yearly visual inspection of the PFC system is a good practice to certify the system is in good working order. It can become quite costly if routine maintenance is not completed as the cabling, capacitors and reactors may become damaged and require replacement. By maintaining the PFC system this can be avoided the expensive cost of replacement can be kept in check.

About CD-Aero

CD-Aero is a leading provider of film capacitors for industrial, medical and specialized applications serving original equipment manufacturers (OEM) and distributors. The company has world-class design, manufacturing and testing facilities in New Bedford, Massachusetts and global manufacturing facilities in China and India to enable quick turn-around for shipping and delivery worldwide.

CD-Aero capacitors are among the world's most reliable components. Our extensive custom design and development capabilities coupled with broad, standardized product offerings allow us to provide intelligent capacitor solutions that meet or exceed our customers' application requirements.

Our aim is to be the best and most sought after provider of capacitor solutions for specialty markets.

CD-Aero Corp.
167 John Vertente Blvd.
New Bedford, MA 02745
Tel: +1-508-910-3500
Fax: +1-508-995-3000
www.CD-Aero.com

CD-Aero China
28 Wangchun Rd.
Ningbo, Zhejiang
China

CD-Aero India
Plot # 30 to 33
Hardware Park
Imarat Kancha
Raviryal Village
Maheshwaram Mandal
R R District – 500 066
Andhra Pradesh State
India

Copyright 2017, CD-Aero Corp. All rights reserved.

CD-Aero is a registered trademark and AeroPower is a trademark of CD-Aero Corp.

PF01704 Printed in the USA