

EM50



Energy analyzer for 3-phase, 2-phase and 1-phase systems



Benefits

- **Flexible installation.** EM50 is suitable for single-phase, two-phase, three-phase and wild-leg systems with different voltage levels used in USA and Canada.
- **Selectable communication protocol.** Modbus RTU and BACnet MS/TP in the same unit.
- **Extended energy measurements.** 4-quadrants reactive power and multi-tariff metering.
- **Easy navigation.** The slideshow function automatically displays the desired measurements in sequence without having to use the keypad.
- **Legal metrology.** The Measurement Canada version can be used for legal metrology in Canada.
- **Quick configuration.** The proprietary UCS configuration software is free and permits quick system configuration.

Description

EM50 is a three-phase energy analyzer for DIN-rail mounting with LCD display. It is equipped with a static output (pulse transmission), a relay output (alarm or remote control function) and Modbus RTU or BACnet MS/TP port. EM50 manages direct voltage connection up to 600 V L-L or by means of voltage transformers. The current measurement is carried out via 5 A current transformer, 333 mV or 80 mA (Measurement Canada only) current sensor or Rogowski coil.

Applications

EM50 is the perfect solution especially in building and industrial automation where energy and main electrical variables monitoring is required. It is particularly suited for energy efficiency monitoring, cost allocation, and fiscal/legal sub-billing, where the Measurement Canada approval is required.

Main functions

- Measure energy consumption and main electrical variables of single-phase, two-phase or three-phase loads
- Display single phase and total variables
- Transmit data via serial communication (Modbus RTU or BACnet MS/TP)
- Transmit energy consumption via pulse output
- Transmit alarm and manage remote control via relay output
- Manage monthly energy log (current month and the previous two months)
- Manage event log database (resets, terminal cover openings, configurations, alarms, etc.)

**Main features**

- Energy measurements: imported and exported kWh, 4-quadrants kvarh and 4 tariffs energy meters; single phase measurements
- Selectable DMD calculation method (fixed, sliding, sliding with selectable refresh time or thermal)
- Real time clock and tariff management

Structure

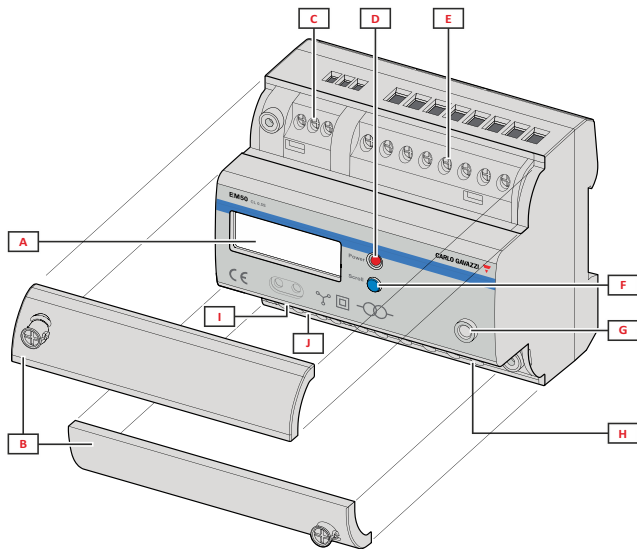

Fig. 1 Front

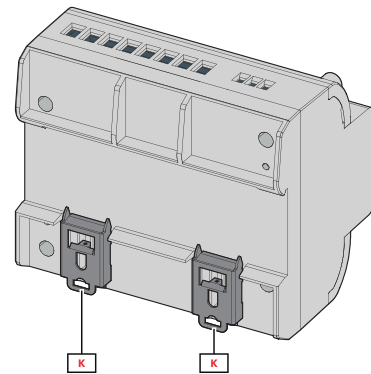

Fig. 2 Back

Area	Description
A	Backlit LCD display
B	Terminal protection covers
C	RS485 connections
D	Power supply LED
E	Current connections
F	Push button for page scrolling
G	Sealable locking cap
H	Power supply and voltage connections
I	Static output and relay connections
J	Push button for programming
K	DIN rail mounting springs

Features

General

Protection degree	Front: IP40 Terminals: IP20
Terminals	Screw terminals Voltage and current: max: 4 mm ² ; min: 0.2 mm ² Outputs and communication: max: 2.5 mm ²
Overvoltage category	Cat. III
Pollution degree	2
Noise rejection (CMRR)	100 db, 45-65 Hz
Mounting	DIN rail
Weight (packaging included)	340 g

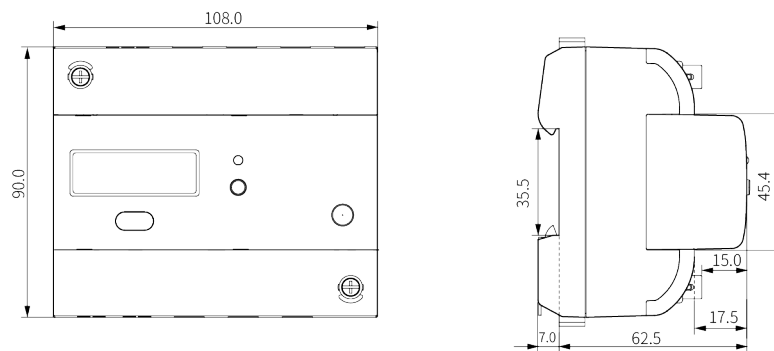

Environmental specifications

Operating temperature	From -25 to +75 °C/from -13 to +167 °F
Storage temperature	From -40 to +85 °C/from -40 to +185 °F



Input and output insulation

Type	Measuring in-puts up to 600V to ground	Relay output	Static output	Communication port	Auxiliary power supply
Measuring in-puts up to 600 V to ground	-	2 kV	2.5 kV*	3 kV**	2 kV
Relay output	2 kV	-	1.5 kV*	3 kV**	2 kV
Static output	2.5 kV*	1.5 kV*	-	2 kV	2.5 kV*
Communication port	3 kV**	3 kV**	2 kV	-	3 kV**
Auxiliary power supply	2 kV	2 kV	2.5 kV*	3 kV**	-

*Note: an isolated S0 reader shall be used when connecting the static output. Not suitable for Class II supply circuit.

**Note: an isolated repeater or converter shall be used when connecting a bus to the serial port.

Compatibility and conformity

Directives	2011/65/EU (RoHs2) 2015/863/EU (Rohs3) 2014/30/EU (EMC) 2014/35/EU (LVD)
Standards	Electromagnetic compatibility (EMC) - emissions and immunity: EN61000-6-3/ EN61000-6-2 Electrical safety: EN 61010-1 Accuracy: EN 62053-22 (Active energy, Class 0.5 s) IEC 62053-23 (Reactive energy, Class 2 and 3)
Approvals	  file E361995 Measurement Canada: LMB-EG-07. Specifications for Approval of Type of Electricity Meters, Instrument Transformers and Auxiliary Devices

Electrical specifications

Voltage inputs	AV5	MV5	RG5	MA5
Voltage connection	Direct or via VT			
Max VT ratio	200000			
Rated voltage L-N (from Un min to Un max)	100 to 347 V			
Rated voltage L-L (from Un min to Un max)	100 to 600 V			
Voltage tolerance	-20%, +15%			
Overload	Continuous: 1.5 Un max			
Input impedance	2 MΩ			
Frequency	50/60 Hz			



Current inputs	AV5	MV5	RG5	MA5
Current connection	Via CT	Via 333 mV current sensor	Via Rogowski coil (100 mV/kA @50 Hz)	Via 80 mA current sensor
Max CT ratio	50000	-	-	-
Rated current (In)	5 A	333 mV	100 mV	80 mA
Minimum current (Imin)	0.05 A	0.01 In	0.01 In	0.8 mA
Maximum current (Imax)	10 A	1.5 In	2 In	160 mA
Start-up current (Ist)	5 mA	0.001 In	0.005 In	0.08 mA
Overload	Continuous: 10 A @ 50/60 Hz 1 s: 100 A @ 50/60 Hz	Continuous: 1.5 In @ 50/60 Hz	Continuous: 2 In @ 50/60 Hz	Continuous: 160 mA @ 50/60 Hz
Input impedance	≤ 0.6 VA	-	-	-
Crest factor	5 (Imax peak 25 A)	1.5	5	4 (Imax peak 320 mA)

Power supply

Version	Standard (suffix X)	Measurement Canada (suffix MC)
Type	Auxiliary power supply	
Voltage range	100-415 V ac, 50/60 Hz; 100-300 V dc	120 V ac, 60 Hz
Consumption	< 2W or < 10 VA	

Measurements

Method	TRMS measurements of distorted waveforms
Sampling	3200 samples/s @50 Hz 3840 samples/s @60 Hz

Available measurements on display

Active energy	Unit	System	Phase
Imported (+) Total	kWh+	•	•

Electrical variable	Unit	System	Phase
Voltage L-N	V	-	•
Current	A	-	•
Neutral current	A	•	-
Active power	kW	•	•
Frequency	Hz	•	-
Run hour meter	h	•	-
Device operating	h	•	-
Internal temperature	°C	•	-

Available measurements via communication

Active energy	Unit	System	Phase
Imported (+) Total	kWh+	Total and by tariff	•
Exported (-) Total	kWh-	Total and by tariff	•

Reactive energy	Unit	System	Phase
Imported (+) Total	kvarh	Total and by tariff	-
Exported (-) Total	kvarh	Total and by tariff	-
Imported (+): Q1	kvarh	Total and by tariff	-
Imported (+): Q2	kvarh	Total and by tariff	-
Exported (-): Q3	kvarh	Total and by tariff	-
Exported (-): Q4	kvarh	Total and by tariff	-

Apparent energy	Unit	System	Phase
Imported (+) Total	kVAh+	•	•
Exported (-) Total*	kVAh-	•	•

Note*: not available in Measurement Canada models.

Electrical variable	Unit	System	Phase
Voltage L-N	V	•	•
Voltage L-L	V	•	•
Current	A	•	•
Neutral current	A	•	-
DMD	A	-	•
DMD max	A	-	•
Active power	kW	•	•
DMD	kW	•	-
DMD max	kW	•	-
Apparent power	kVA	•	•
DMD	kVA	•	-
DMD max	kVA	•	-
Reactive power	kvar	•	•
DMD	kW	•	-
DMD max	kW	•	-
Power factor	PF	•	•
Frequency	Hz	•	-
Run hour meter	h	•	-
Device operating	h	•	-
Internal temperature	°C	•	-

Measurement accuracy

Current	
From I _{min} to I _{max}	± 0.5% rdg

Phase-phase voltage	
In the range U _n	± 0.5% rdg

Phase-neutral voltage	
In the range U _n	± 0.5% rdg

Reactive power	
Active power	± 0.5% rdg
Apparent power	± 0.5% rdg
Reactive power	± 0.5% rdg
Active energy	Class 0.5S (IEC 62053-22) Class 0.5 (ANSI C12.20)
Reactive energy	Class 2.0 S (IEC 62053-23)

Frequency	
From 45 to 65 Hz	± 0.2% rdg

Display

Type	Backlit LCD
Refresh time	< 1000 ms
Description	7 digits (8 mm)
Variable readout	Instantaneous: min: 0.000; max: 9999.999 Energy: 7 digits; min: 0.0; max: 999999.9



Digital outputs

Static output

Connection type	Screw terminals
Maximum number of outputs	1
Type	Mosfet
Function	Pulse output
Features	V _{ON} 0.35 V dc, max. 100 mA V _{OFF} 250 V max
Configuration parameters	Linked variable (Active power/Reactive power) Pulse duration (20-100 ms) Pulse weight (1-60000 pulse/kWh or pulse/kvarh)
Configuration mode	Via keypad or UCS software

Note: an isolated S0 reader shall be used when connecting the static output. Not suitable for Class II supply circuit.

Relay output

Connection type	Screw terminals
Maximum number of outputs	1
Type	Relay (SPST)
Function	Remote control or alarm
Features	5A@250 V ac 5A@30 V dc
Configuration parameters	Function Alarm Output Mode (level/ pulse) Pulse Output Time (50-3000 ms) Delay (0-30000 ms)
Configuration mode	Via UCS software

Note: an isolated S0 reader shall be used when connecting the static output. Not suitable for Class II supply circuit.

Communication ports

RS485 port

Protocol	Modbus RTU
Devices on the same bus	Max 247
Communication type	Multidrop, bidirectional
Connection type	2 wires
Configuration parameters	Modbus address (from 1 to 247) Baud rate (1200/2400/4800/9600/19200/38400/115200 bps) 1 stop bit, no parity / 2 stop bit no parity / 1 stop bit, even parity / 1 stop bit, odd parity
Refresh time	< 200 ms
Configuration mode	Via keypad or UCS software

Note: an isolated repeater or converter shall be used when connecting a bus to the serial port

BACnet MS/TP

Protocol	BACnet MS/TP
Communication type	Multidrop, monodirectional
Connection type	2-wires, maximum distance 1000 m
Supported services	I-have, I-am, Who-has, Who-is, Read-property (multiple)
Supported objects	Type 2 (analogue value) Type 8 (device)
Configuration parameters	Maximum information frame number (from 10 to 255) Instance number (from 1 to 4194302) Baud rate (9.6/19.2/38.4/76.8 kbps) MAC address (from 0 to 127)
Configuration mode	Via keypad

Connection Diagrams

Three-phase with neutral (4-wire)

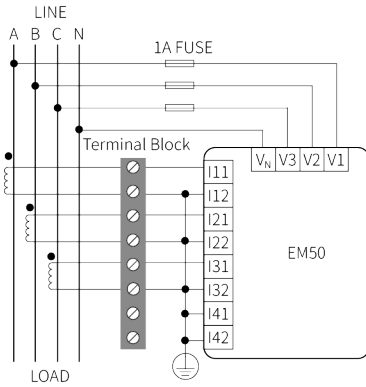

Fig. 3 AV5

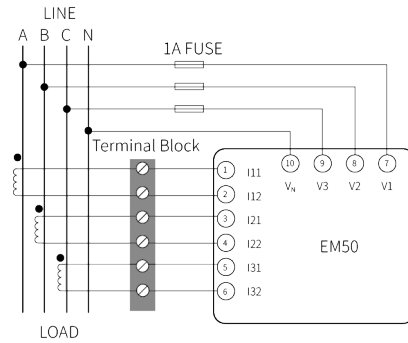

Fig. 4 MV5, RG5, MA5

Three-phase without neutral (3-wire). Voltage connection via VT

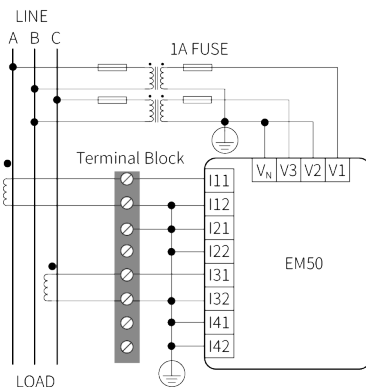

Fig. 5 AV5

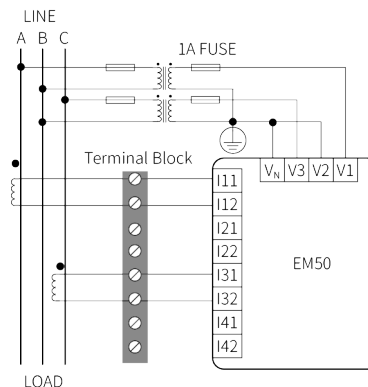

Fig. 6 MV5, RG5, MA5

Two-phase (3-wire)

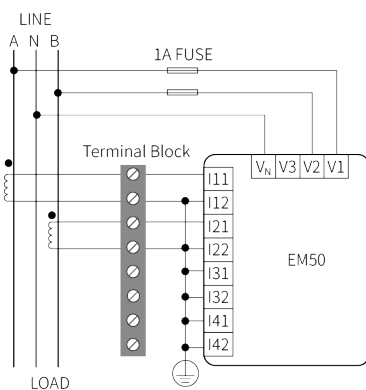

Fig. 7 AV5

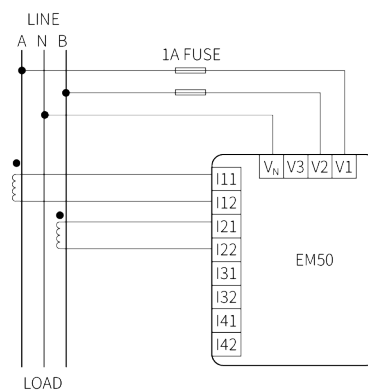

Fig. 8 MV5, RG5, MA5

Three-phase without neutral (3-wire). Direct connection

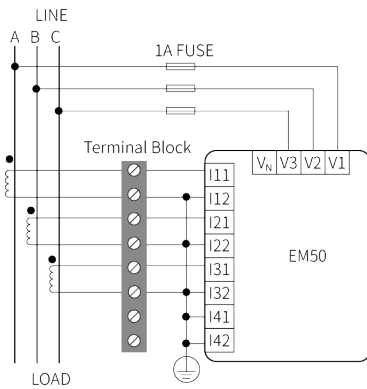

Fig. 9 AV5

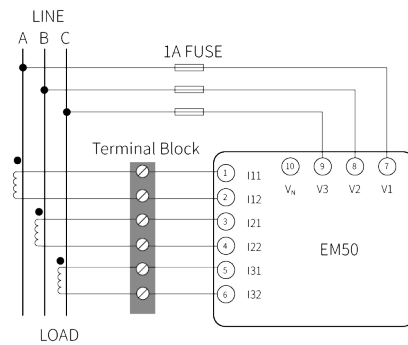

Fig. 10 MV5, RG5, MA5

Single-phase (2-wire)

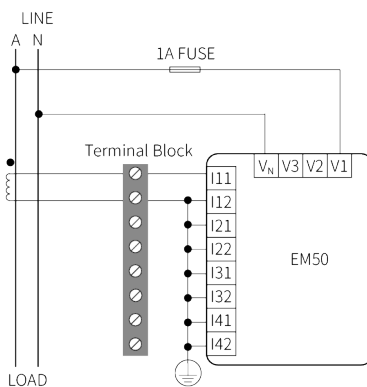

Fig. 11 AV5

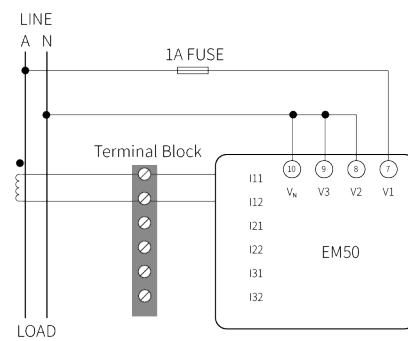

Fig. 12 MV5, RG5, MA5

References

Order code

Measurement Canada

Component name/part number	I/O communication	Voltage inputs	Current inputs	Power supply	System
EM50DIN MA5 3H RS MC	Static output, relay output, Modbus RTU	347 V L-N 600 V L-L	80 mA	Auxiliary power supply	3-phase
EM50DIN AV5 3H RS MC	Static output, relay output, Modbus RTU	347 V L-N 600 V L-L	5 (10) A	Auxiliary power supply	3-phase

Standard

Component name/part number	I/O communication	Voltage inputs	Current inputs	Power supply	System
EM50DIN AV5 3H RS X	Static output, relay output, Modbus RTU	347 V L-N 600 V L-L	5 (10) A	Auxiliary power supply	3-phase 2-phase 1-phase
EM50DIN MV5 3H RS X	Static output, relay output, Modbus RTU	347 V L-N 600 V L-L	333 mV	Auxiliary power supply	3-phase 2-phase 1-phase
EM50DIN RG5 3H RS X	Static output, relay output, Modbus RTU	347 V L-N 600 V L-L	Rogowski	Auxiliary power supply	3-phase 2-phase 1-phase



COPYRIGHT ©2020
Content subject to change. Download the PDF: www.productselection.net