

30.5mm Pushbuttons and Accessories

Pushbuttons 30.5mm

Australia and New Zealand

EATON

Powering Business Worldwide

Contents

Corporate Overview.....	1
Pushbutton Introduction.....	2
Standard Pushbuttons.....	3
Flush, Extended & Half-Shrouded Buttons.....	5
Mushroom Operators Momentary.....	6
Push-Pull Mushroom Operators Maintained.....	6
Mushroom Operator Components.....	7
Push-Pull Operator Components.....	8
Mechanically Interlocked Pushbuttons.....	9
Contact Blocks.....	10
Illuminated Operators.....	11
Indicating lights.....	12
Illuminated Pushbuttons.....	14
Illuminated Push-Pull Operators.....	16
Bulbs.....	18
Selector Switches and Joystick Operators.....	19
Selector Switches.....	20
Key Operated Selector Switches.....	21
Cam Selection Guide.....	22
Illuminated Selector Switches.....	23
Joystick Operators.....	24
Control Stations and Enclosures.....	27
Enclosures.....	28
Assembled Control Stations.....	29
Accessories.....	30
Technical Data and Dimensions.....	36



Powering Business Worldwide

Corporate overview

Powering Business Worldwide

Founded in 1911, Eaton® Corporation is a diversified industrial manufacturer and a global leader in various industrial markets, including:

- Electrical systems and components for power quality, distribution and control
- Hydraulic components, systems and services for industrial and mobile equipment
- Hydraulics, fuel and pneumatic systems for commercial and military aircraft
- Intelligent truck drivetrain systems for safety and fuel economy
- Automotive engine air management systems, powertrain solutions and specialty controls for performance, fuel economy and safety

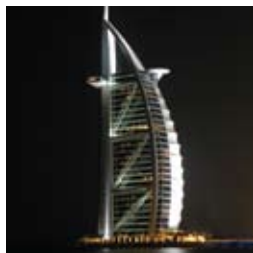

With 2008 sales of \$15.4 billion USD, Eaton employs 75,000 people all over the world and sells products to customers in more than 150 countries.

Pushbutton Introduction



Eaton's 30.5mm pushbuttons are versatile, durable, rugged, and stand the test of time in even the most hostile environments.

The range includes momentary, illuminated and mushroom head pushbuttons, selector switches, indicating lights and push-pull units.

The T Series Chrome 30.5 mm pushbutton line features a zinc die cast construction with chrome-plated housing and mounting nut. The same durable construction is also available with the corrosive resistant E34 line of pushbuttons.

All operators are IP66 rated to protect against dirt and moisture. Additionally, most devices come complete with grounding hardware to prevent electrical shock. Rugged metal construction, handsome appearance, extra features, and competitive prices makes Eaton's 30.5mm range of pushbuttons the logical choice for OEM's and board builders looking for value, durability, and reliability.

Contact Blocks

Eaton's contact blocks feature enclosed silver contacts with pointed "reliability nibs" for reliable performance from logic level up to 600V. To ensure reliable switching, nibs bite through oxide which can form on silver contacts, eliminating the need for expensive logic level blocks for most applications.

Reliability nibs improve performance in dry circuit, corrosive, fine dust and other contaminated atmospheres. Under normal environmental conditions, the minimum operational voltage is 5V and the minimum operational current is 1 mA, AC/DC. For operation under a wider range of environmental conditions, logic level contact blocks with inert palladium tipped contacts are recommended. Diaphragm Seal with Drainage Holes Eaton's pushbutton operators offer front-of-panel drainage via holes in the operator bushing. Hidden from view by the mounting nut, these holes prevent buildup of liquid inside the operator, which can prevent operation in freezing environments. The holes also provide a route for escaping liquid in high pressure washdowns, effectively relieving pressure from the internal diaphragm seal, ensuring reliable sealing every time.

Grounding Nibs

Most operators have green earthing screws to prevent electrical shock. Operators also have "grounding nibs" — four metal points on the operator casting designed to bite through most paints and other coatings on metal panels to enhance the ground connection when the operator is securely tightened.

All operators are IP66 rated to protect against dirt and moisture.

Features

- Die-cast metal housings create robust and heavy-duty devices that can endure repetitive and heavyhanded use in industrial environments.
- IP66 rated for protection against dirt and moisture.
- The corrosion resistant E34 range can withstand extremely harsh environments.
- Contact blocks are colour coded (green for N.O. and red for N.C.) to permit easy identification and troubleshooting.
- Up to 6 contact blocks can stack on each other, allowing for up to 12 circuits per operator.
- Heavy-duty zinc die cast construction
- Enclosed silver contacts with reliability nibs
- All normally closed contacts have positive opening operation, i.e., normally closed contacts are forced open in the event of contact weld or spring breakage.
- Diaphragm seals with drainage holes
- Grounding nibs on the operator casing.
- Logic level contact blocks have palladium tipped contacts to ensure circuit integrity down to 1mA @ 5V AC/DC.
- Bright, long-lasting and vibration-proof LED's are available for illuminated operators.

Standards

- CE EN60947-5-1
- UL 508 — File No. 131568
- CSA C22.2 No. 14 — File No. LR68551



Powering Business Worldwide



Standard Pushbuttons

Standard, Mushroom, Palm and
Mechanically Interlocked Pushbuttons

Chrome T Series Pushbuttons



Chrome

The 30.5 mm pushbutton line features a zinc die cast construction with chrome-plated housing and mounting nut.

Ultraviolet Light

E34 cathodic coating is not recommended for use in applications where exposure to ultraviolet light exists, use chrome operators.

Applications for the Chrome Operators:

- Aggregate
- Automotive
- Construction Vehicles
- Industrial Equipment
- Material Handling
- Metal Forming
- Metal Stamping
- Mining
- Petrochemical
- Pulp & Paper

Corrosion Resistant E34 Pushbuttons



Corrosion Resistant

Eaton's Corrosion Resistant E34 Range of 30.5 mm pushbuttons features the same rugged die cast construction of our T Series with an additional two-layer 100% solid thermosetting cathodic epoxy coating. This coating provides a smooth flat black smooth, flat back, corrosion resistant surface that has passed a demanding 600 hour salt spray test.

Applications for Corrosion Resistant Operators:

- Automotive
- Chemical Plants
- Food & Beverage
- Food Service Equipment
- Industrial Equipment
- Mining
- Pulp & Paper
- Waste Water Treatment Plants



Powering Business Worldwide

Flush, Extended & Half-Shrouded Buttons



Flush Button		
Colour	Chrome	Corrosion Resistant
● Black	T101	E34PB1
● Red	T102	E34PB2
● Green	T103	E34PB3
● Yellow	T104	E34PB4
● Grey	T105	-
○ White	T106	E34PB5
● Brown	T107	-
● Blue	T108	E34PB6



Extended Button		
Colour	Chrome	Corrosion Resistant
● Black	T111	E34EB1
● Red	T112	E34EB2
● Green	T113	E34EB3
● Yellow	T120	E34EB4
● Blue	T118	E34EB6
○ White	T116	-



Half-Shrouded		
Colour	Chrome	Corrosion Resistant
● Black	T501	E34EVB1
● Red	T502	E34EVB2
● Green	T503	E34EVB3
● Yellow	T504	E34EVB4
● Blue	T508	E34EVB6

Step 1



Select Pushbutton operator above.

Step 2



Select contact block from Page 7

Mushroom Operators Momentary



Mushroom Button 38.1mm		
Colour	Chrome	Corrosion Resistant
● Black	T121	E34LB1
● Red	T122	E34LB2
● Green	T123	E34LB3
● Yellow	T124	E34LB4
● Blue	T129	E34LB6



Palm Head Button 63.5mm Zinc		
Colour	Chrome	Corrosion Resistant
● Black	T171	E34JB1
● Red	T172	E34JB2
● Red (Emergency Stop)	T17213	E34JB2N
● Green	T173	E34JB3

Push-Pull Mushroom Operators Maintained



T129P



T176P

Push-Pull Operators Complete Padlockable				
Head Diameter	Colour	Material	Chrome	Corrosion Resistant
45mm	Red	Zinc	T129P	E34129P
63.5mm	Red	Zinc	T176P	E34176P



T129M



E34129S

Push-Pull Operators Complete Non-Padlockable				
Head Diameter	Colour	Material	Chrome	Corrosion Resistant
38mm	Red	Plastic	T129S	E34129S
45mm	Red	Zinc	T129M	E34129M
63.5mm	Red	Zinc	T176M	E34176M

Step 1

Select pushbutton operator above.

Step 2

Select contact block from Page 7

Mushroom Operators Accessories



Accessories for Complete Push-Pull Operators*	
Description	Cat.No
Padlock Assembly Kit	6-A474
Replacement Locking Tongue	6-A475
Padlock with Chain	52-A1617

Legend Plates		
Engraving	Material	Cat.No
STOP Pull to reset	Metal	D2179-53CP
STOP Pull to reset	Plastic	E34LP179

* For use with push-pull mushroom operators maintained.

Mushroom Operator Components



Bare Shaft Operator for Mushroom or Palm Pushbutton	
Description	Cat.No
Momentary, Spring Return	T100
Auto-Latch - Twist Base to Release	T140



38.1 Mushroom Button	
Colour	Cat.No
● Black	T281
● Red	T282
● Green	T283
● Yellow	T284
● Blue	T288



63.5mm Palm Button (Anodized Aluminium)	
Colour	Cat.No
● Black	T291
● Red	T292
● Green	T293

Step 1

Select bare shaft operator above

Step 2

Select Mushroom button from above

Step 3





Select contact block from page 7

Push-Pull Operator Components





Push-Pull Operators			
Description	Position	Chrome	Corrosion Resistant
Maintained Push & Pull	2	T5	E34GDB
Momentary Push & Pull	3	T4	E34GEB
Maintained Push & Momentary Pull	3	T9	E34GFB



38.1mm Mushroom Button		
Description	Colour	Cat. No
38.1mm Operator Head	 Red	E34C2
38.1mm Operator Head	 Red (Emergency Stop)	E34C2N8
38.1mm Operator Head	 Green	E34C3
38.1mm Operator Head	 Black	E34C1



63.5mm Palm Button (Anodized Aluminium)		
65mm Operator Head	 Red	E34J2
65mm Operator Head	 Red (Emergency Stop)	E34J2N8

Step 1



Select push-pull operator above

Step 2



Select mushroom button from above

Step 3



Select contact block from page 9

Mechanically Interlocked Pushbuttons



Mechanically Interlocked Pushbutton Operators		
Top Button	Bottom Button	Cat. No
● Black flush	● Green flush	10250TA66
● Black flush	● Red extended	10250TA67
● Black flush	● Red mushroom	10250TA68
● Black flush	● Red mushroom - padlockable	10250TA69
● Black flush	● Red palm	10250TA76
● Green flush	● Red extended	10250TA72
● Black extended	● Red extended	10250TA73
● Green flush	● Red mushroom	10250TA77
● Green flush	● Black flush	10250TA75

Step 1



Select mechanically interlocked pushbutton above

Step 2



Select contact blocks from page 10

Contact Blocks



Standard Contact Blocks

Description	Part. No
1NO 1NC	T1P
2NO	T2P
2NC	T3P
1NC	T51P
1NO	T53P
2NO 2NC	T44
1LONC 1ECNO	T55
1ECNO 1NO	T57
1LONC	T71
2LONC	T45

Base Mounted Contact Blocks

Description	Part. No
1NO 1NC	T6
2NO	T7
2NC	T8
1NC	T52
1NO 1NC	T54
1LONC 1ECNO	T56
1LONC 1ECNO	T58

Logic Level Contact Blocks

Description	Part. No
1NO 1NC	T1E
2NO	T2E
2NC	T3E
1NC	T51E
1NO	T53E

NO = Normally Open, NC = Normally Closed, LONC = Late Open Normally Closed, ECNO = Early Close Normally Open, Logic Level contact blocks have palladium contacts.

A close-up photograph of a control panel. The panel features several rectangular buttons and indicators, all of which are illuminated with a bright green light. The buttons are arranged in a vertical column. The background is dark, making the glowing green elements stand out prominently. The overall aesthetic is industrial and functional.

Illuminated Operators

Indicating Lights, Illuminated
Pushbuttons and Press Test Units

Indicating Light Lenses



Plastic Lenses		
	Colour	Plastic
●	Red	E34H2
●	Green	E34H3
●	Amber	E34H9
●	Blue	E34H6
○	Clear	E34H0
○	White	E34H5
●	Yellow	E34H4



Glass Lenses (Chrome)		
	Colour	Glass (Chrome)
●	Red	TC7N
●	Green	TC8N
●	Amber	TC9N
●	Blue	TC10N
○	Clear	TC11N
○	White	TC12N



Glass Lenses (Corrosion Resistant)		
	Colour	Glass (Corrosion Resistant)
●	Red	E34G2
●	Green	E34G3
●	Amber	E34G9
●	Blue	E34G6
○	Clear	E34G0
○	White	E34G5
●	Yellow	E34G4

Indicating Light Units



Direct Voltage Indicating Light Unit			
Description	Voltage	Chrome	Corrosion Resistant
Direct voltage - order bulb separately	6 - 240V	T197N	E34FB

See page 18 for bulbs. can be used with LEDs.



Incandescent Bulb Indicating Light Units			
Description	Voltage	Chrome	Corrosion Resistant
With incandescent bulb supplied	6	T197N/2	E34FB06
	12	T197N/3	E34FB12
	24	T197N/4	E34FB24
	48	T197N/5	E34FB48
	110	T197N/7	E34FB110
	240	T197N/8	E34FB240



Transformer Type Indicating Light Units			
Description	Voltage	Chrome	Corrosion Resistant
Transformer Type 6V Secondary bulb supplied	110/120	T181N	E34TB120
	220/240	T182N	E34TB240
	380/415	T183N	E34TB380
	440/480	T184N	E34TB480
	550/600	T185N	E34TB600
	415		E34TB415

Resistor Type Indicating Light Units			
Description	Voltage	Chrome	Corrosion Resistant
Resistor Type 120V bulb supplied	110/120	T201N	E34RB120
	220/240	T202N	E34RB240

Step 1



Select lens from previous page

Step 2



Select indicating light from above

Step 3



Select bulb if not supplied with indicating light

Step 4



Select contact block from page 10

Illuminated Pushbutton Lenses



Plastic Illuminated Lenses		
	Colour	Plastic
●	Red	E34V2
●	Green	E34V3
●	Amber	E34V9
●	Blue	E34V6
○	Clear	E34V0
○	White	E34V5
●	Yellow	E34V4



Glass Illuminated Lenses (Chrome)		
	Colour	Glass (Chrome)
●	Red	TC13N
●	Green	TC14N
●	Amber	TC15N
●	Blue	TC16N
○	Clear	TC17N
○	White	TC18N



Glass Illuminated Lenses (Chrome)		
	Colour	Glass (Chrome)
●	Red	E34P2
●	Green	E34P3
●	Amber	E34P9
●	Blue	E34P6
○	Clear	E34P0
○	White	E34P5
●	Yellow	E34P4

Illuminated Pushbutton Light Units



Illuminated Pushbuttons - Direct Voltage			
Description	Supply Voltage	Chrome	Corrosion Resistant
Direct Voltage Order bulb separately	6-240V	T441	E34CB

See page 18 for bulbs. Can be used with LEDs.



Illuminated Pushbuttons - Transformer Type			
Description	Supply Voltage	Chrome	Corrosion Resistant
Transformer type 6V secondary bulb supplied	110/120	T411	E34XB120
	220/240	T412	E34XB1240
	380/415	T413	E34XB380
	440/480	T414	E34XB480

Press-To-Test Light Units



Press-To-Test Indicating Lights - Direct Voltage			
Description	Supply Voltage	Chrome	Corrosion Resistant
Direct voltage order bulb separately	6-240V	T230N	E34FPB
	380/415	T413	E34XB380

See page 18 for bulbs. Can be used with LEDs.

Press-To-Test Indicating Lights - Transformer Type			
Description	Supply Voltage	Chrome	Corrosion Resistant
Transformer Type 6V, 1W secondary bulb supplied	110/120	T221N	E34TPB120
	220/240	T222N	E34TPB240
	380/415	T223N	E34TPB380

Press-To-Test Indicating Lights - Resistor Type			
Description	Supply Voltage	Chrome	Corrosion Resistant
Resistor Type 120V, bulb supplied	110/120	T231N	E34RPB120
	220/240	T240N	E34RPB240

Step 1



Select lens from previous page

Step 2



Select light from above

Step 3



Select bulb if not supplied with indicating light

Step 4



Select contact block from page 10

Push-Pull Mushroom Lenses



Standard Push-Pull Lenses		
Colour		Cat. No
●	Red	E34M2
●	Red (Emergency Stop)	E34M2N8
●	Green	E34M3
●	Blue	E34M6
●	Amber	E34M9
○	White	E34M5
○	Clear	E34M0



Side Lighted Anodised Aluminium Lenses		
Colour		Cat. No
●	Red	10250TC57
●	Red (Emergency Stop)	10250TC63
●	Green	10250TC58
●	Blue	10250TC59
●	Amber	10250TC64
○	White	10250TC61
○	Clear	10250TC62



Heavy Duty Aluminium with Transparent Centre		
Colour		Cat. No
●	Red	10250TC65
●	Green	10250TC66
●	Amber	10250TC67

Illuminated Push-Pull Operators



Illuminated Push-Pull Operators			
Description	Positions	Chrome	Corrosion Resistant
Maintained Push & Pull	2	T5	E34GDB
Momentary Push & Pull	3	T4	E34GEB
Maintained Push & Momentary Pull	3	T9	E34GFB

Light Units for Illuminated Push-Pull Operators



Direct Voltage Light Modules for Push-Pull Operators		
Description	Voltage	Cat. No
Direct Voltage	6-240V	10250T70

Note: Order bulb separately. See page 18 for bulbs. Can be used with LEDs.

Transformer Type Light Modules for Push-Pull Operators		
Description	Voltage	Cat. No
Transformer Type 6V secondary bulb supplied	110/120	10250T63
	220/240	10250T65
	380/415	10250T66
	440/480	10250T67

Resistor Type Light Modules for Push-Pull Operators		
Description	Voltage	Cat. No
Resistor Type 120V bulb supplied	120	10250T80
	240	10250T81

Step 1

Select lens from previous page

Step 2

Select push-pull operator from above

Step 3

Select light unit from above

Step 4

Select bulb if not supplied with light unit

Step 5

Select contact block from page 10

Bulbs



Incandescent Bulbs		
Supply Voltage	Watts	Part Number
6.3V	0.9W	28-2225-33
12V	1.2W	21BA9S12
24V	1.2W	28-2225-13
30V	1.2W	21BA9S30
130V	2.2W	28-2225-24



Bright LED Bulbs - Single Chip (AC/DC)					
Colour	6V	12V	24V	110V	240V
Red	21BA9SL6R	21BA9SL12R	21BA9SL24R	21BA9SL110R	21BA9SL240R
Green	21BA9SL6V	21BA9SL12V	21BA9SL24V	21BA9SL110V	21BA9SL240V
Yellow	21BA9SL6G	21BA9SL12G	21BA9SL24G	21BA9SL110Y	21BA9SL240A
White	21BA9SL6W	21BA9SL12W	21BA9SL24W	21BA9SL110W	21BA9SL240W



Super Bright LED Bulbs (Recognisable in outdoor daylight applications - AC only)			
Colour	6-12V	24V	120V
Red	E22LED612RN	E22LED024RN	E22LED120RN
Green	E22LED612GN	E22LED024GN	E22LED120GN
Yellow	E22LED612YN	E22LED024YN	E22LED120YN
White	-	-	E22LED120WN



Neon Bulbs		
Supply Voltage	Colour	Part Number
110V	Clear	21BA9S110N
240V	Clear	21BA9S240N
240V	Green	21BA9S240NG



Selector Switches & Joystick Operators

Knobs, Levers, Joysticks, and Illuminated Selector Switches

Selector Switch Operators



2 Position Selector Switches		
Description (M = Maintained, S = Spring Return)	Chrome	Corrosion Resistant
	T4011	E34VFB
	T4081	E34VEB

3 Position Selector Switches			
Description (M = Maintained, S = Spring Return)	Cam Code*	Chrome	Corrosion Resistant
	2	T4022	E34VGB
	3	T4023	E34VHB
	4	T4024	-
	6	T4026	-
	2	T4032	E34VJB
	3	T4033	E34VKB
	2	T4042	E34VLB
	3	T4043	E34VMB
	2	T4052	E34VNB
	3	T4053	E34VPB

4 Position Selector Switches			
Description	Cam Code*	Chrome	Corrosion Resistant
Maintained	7	T4067	E34VTB

* Note: See page 20 for cam selection guide

Selector Switch Knobs and Levers

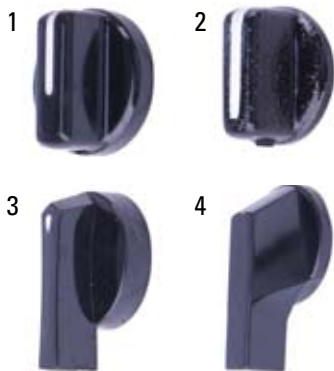

Knobs and Levers			
Description	Material	Image	Part Number
Knob	Plastic	1	E34K1
	Metal	2	T341M
Lever	Plastic*	3	E34L1
	Metal	4	E34A1

* Note: For maintained operators only

Step 1



Choose selector switch operator from above

Step 2

Choose cam based on contact sequence from cam selection guide table on page 22 (applies to 3 position selector switches only)

Step 3



Choose knob or lever from above

Step 4



Select contact block according to cam selection guide on page 22

Key Operated Selector Switches



2 Position Key Operated Selector Switches				
2 Position	Cam	Key Removal	Chrome	Corrosion Resistant
	-	Right and Left	T15113	E34KFB3
	-	Left Only	T15712	E34KEB2



3 Position Key Operated Selector Switches				
3 Position	Cam*	Key Removal	Chrome	Corrosion Resistant
	2	Left Right and Centre	T15227	E34KGB7
	3	Left Right and Centre	T15237	E34KHB7
	4	Left Right and Centre	T15247	-
	6	Left Right and Centre	T15267	-
	2	Right and Centre	T15325	E34KJB5
	3	Right and Centre	T15335	E34KKB5
	2	Centre Only	T15424	E34KLB4
	3	Centre Only	T15434	E34KMB4

* Note: See page 20 for cam selection guide



Spare Key	
Description	Cat. No
Replacement Keys (2)	TA152

Note: Other key codes are available contact Eaton for more information.

Step 1



Choose key selector switch operator from above

Step 2

Choose cam based on contact sequence from cam selection guide table on page 22 (applies to 3 position selector switches only)

Step 3



Select contact block according to cam selection guide on page 22

Cam Selection Guide







Cam Selection Chart Showing Contact Sequence							
Catalogue Number of contact block	Circuit (1)	2 position selector switch	3 position selector switch				4 position selector switch
			Cam code no. 1	Cam code no. 2	Cam code no. 3	Cam code no. 4	
T1P	A.N.C.	X0	OX0	OXX	X00	X00	X000
	B.N.O.	OX	OOX	OOX	OX0	OX0	OX00
T1P	A.N.O.	OX	XOX	X00	OXX	OOX	OOX0
	B.N.C.	X0	XX0	XX0	XOX	OOX	000X
T2P	A.N.O.	OX	XOX	X00	OXX	OOX	OOX0
	B.N.O.	OX	OOX	OOX	OX0	OX0	OX00
T3P	A.N.C.	X0	OX0	OXX	X00	X00	X000
	B.N.C.	X0	XX0	XX0	XOX	OOX	000X

Switching angle 60° between each position. Rated for AC only.

Refer to actual installation instructions given with each switch for additional switching combinations. To determine the number of the cam you require and the correct contact block, select the contact sequence desired from table above. 0 = contacts open, X = contacts closed. The cam number is shown at top of column. The catalogue number of the appropriate contact block is shown in column 1. at extreme left of table.









(1) Note : Each contact block contains two contact circuits. The top set of contacts is identified as 'Circuit A' and the lower set as 'Circuit B' is indicated in the table. The chart shows the contact arrangements with the three contact blocks available and in each operator position. Additional contacts are obtainable by stacking contact blocks up to a maximum of 6 blocks (12 circuits). A maximum of 2 can be used with cam 6.

Illuminated Selector Switches

Illuminated Selector Switch Operators							
Positions	Operator Action	Transformer Type			Full Voltage Type — AC or DC		
		6 Volt #755 Lamp			Voltage	Cat. No	Cam Code
		Voltage	Cat. No	Cam Code*			
2-Position – 60° Throw		120	10250T5971	1	120	10250T6361	1
		240	10250T5981				
3-Position – 60° Throw		120	10250T603_	+ 2 or 3	120	10250T638_	+ 2 or 3
		240	10250T604_				
		120	10250T620_	+ 2 or 3	120	10250T622_	+ 2 or 3
		240	10250T656_				
		120	10250T621_	+ 2 or 3	120	10250T623_	+ 2 or 3
		240	10250T662_				
		120	10250T615_	+ 2 or 3	120	10250T640_	+ 2 or 3
		240	10250T616_				
4-Position – 40° Throw		120	10250T6097	7	120	10250T6427	7
		240	10250T6107				

* Note: See page 22 for cam selection guide. For replacement bulbs, see page 18

Illuminated Knobs and Levers

Illuminated Knobs and Levers			
Colour	Knob Cat. No	Lever Cat. No	
			
 Red	10250TER	10250TFR	
 Green	10250TEG	10250TFG	
 Yellow	10250TEA	10250TFA	
 Blue	10250TEL	10250TFL	
 Clear	10250TEC	10250TFC	
 White	10250TEW	10250TFW	
 Amber	10250TEM	10250TFM	

Step 1



Choose illuminated selector switch operator from above

Step 2

Choose cam based on contact sequence from cam selection guide table on page 22 (applies to 3 position selector switches only)

Step 3



Choose illuminated knob or lever from above

Step 4



Select contact block according to cam selection guide on page 22

Joystick Operators

Two-Position Joystick Operators

The device mounts in the standard 30.5 mm mounting hole.

Four-Position Joystick Operators

The joystick operated control unit is intended for AC application only. The panel area required for the 4-position operator is equivalent to two standard pushbutton operators.

Latched Joystick Operators

The latch holds the lever in the centre position. The trigger latch must be released before lever can moved into any position.



2 position Operator

2 Position Joystick Operator	
Description	Cat. No
2 position Operator - Momentary Up and Down	T452



Latched Operator

4 Position Joystick Operators (Spring Return ONLY)

Description	Cat. No
4 position - Without Latch	T450
4 position - With Latch	T460



4 position without latch

4 Position Joystick Operators (Maintained)

Description	Cat. No
4 position - Without Latch	10250T451_*
4 position - With Latch	10250T461_*

*Maintained Position

For maintained position (non-spring return), locate required maintained position or positions of operating lever in the Maintained table below and add appropriate Suffix Number to the Catalogue Number selected from the table above.

Maintained Positions				
Up	Down	Left	Right	Suffix Number*
X	—	—	—	1
—	X	—	—	2
—	—	X	—	3
—	—	—	X	4
X	X	—	—	5
X	—	X	—	6
X	—	—	X	7
—	X	X	—	8
—	X	—	X	9
—	—	X	X	10
X	X	X	—	11
X	X	—	X	12
X	—	X	X	13
—	X	X	X	14
X	X	X	X	15

Selector Switches & Joystick Operators

Contact Block Selection and Mounting						
Handle Position			Contact Block		Mounting Location	
Up	Centre	Down	Cat. No	Type	Top A	Bottom B
X	0	0	T51P	1NC		
0	0	X	T51P	1NC		
0	X	0	T45	2LONC		
X	0	0	T3P	1NC 1NC		
0	0	X	T3P	1NC 1NC		
X	X	0	T45	1NONC 1NONC		
0	X	X	T45	1NONC 1NONC		
X	0	0	T44	1NC		
0	0	X	T44	1NO		
0	0	X	T44	1NC		
V	0	0	T44	1NO		

X = closed circuit, 0 = open circuit. See Figure 1 for "A" and "B" mounting location.
 NO = Normally Open, NC = Normally Closed, LONC = Late Opening Normally Closed.
 Four circuits in single block depth — rated 300V max.

Application Caution

Joystick operators are not recommended on certain DC applications above 24V DC which may involve lightly engaging the contacts (teasing) to achieve speed control, positioning, jogging, etc. Excessive arcing and deterioration of the contacts will occur.

Figure 1, A and B Mounting Location

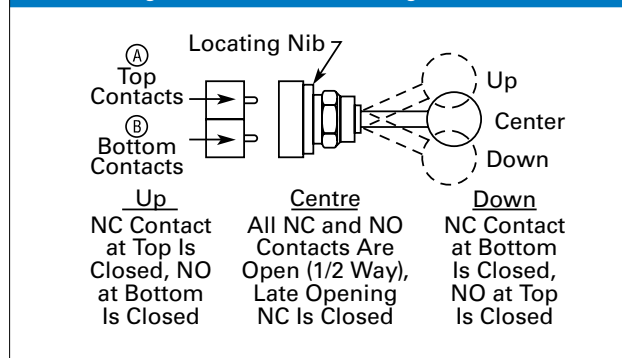

Four-Position Joystick Operators - Contact Block Operation

Contact blocks mount directly on the back of the operator. For reliable operation, the maximum number of contact blocks that should be installed behind each operator lever is 2 (4 contacts total). Figure 2 identifies the circuits activated by each of the eight possible lever positions. Contact block plungers 1, 2, 3, 4 are depressed (change state) when handle is in the position indicated by arrows in Figure 2.

Figure 2, Circuit Activation

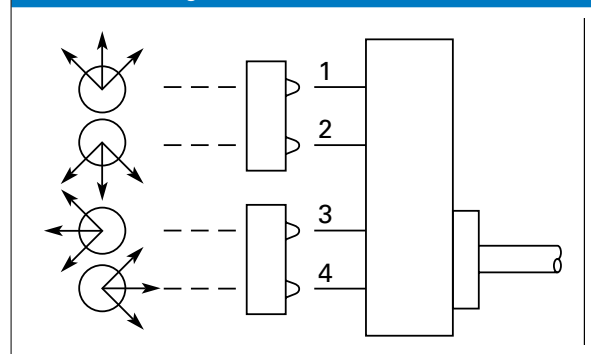

Joystick Operators

Field Conversion — Gate

The factory assembled 4-position operator is assembled with a gate arranged for four handle positions.

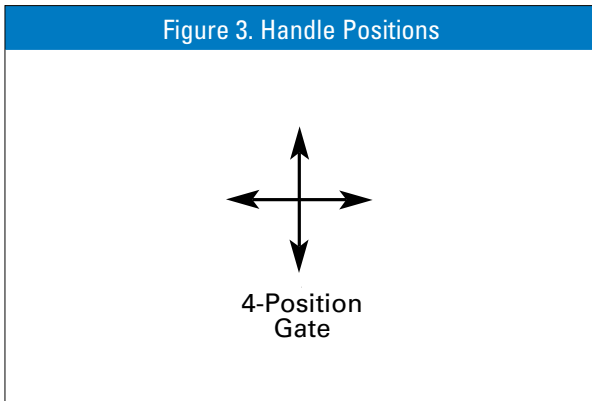

Three additional gates, supplied with every operator, allow on-site conversion to 3 or 8-position operation as illustrated below.

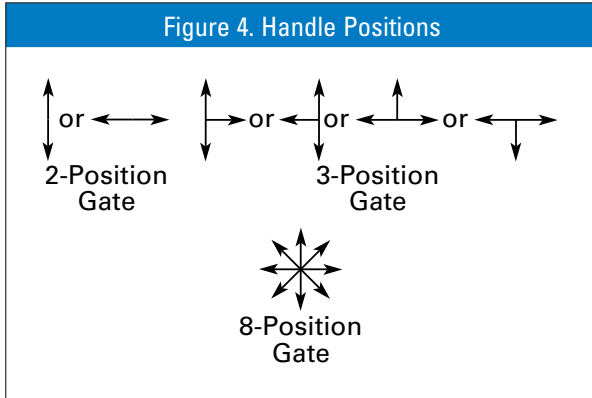

The 8-position gate controls the four functions shown as “Up,” “Down,” “Left” and “Right.” The remaining four diagonal positions each actuate two adjacent functions (see Figure 5); for example, “Left Down” actuates both “Left” and “Down.” The operator may be arranged for spring return of handle to centre position, or maintained in up to eight positions.

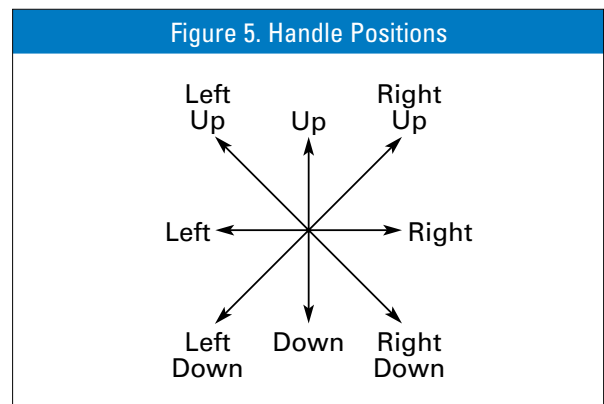

Control Stations and Enclosures

Enclosures and Assembled Control Stations

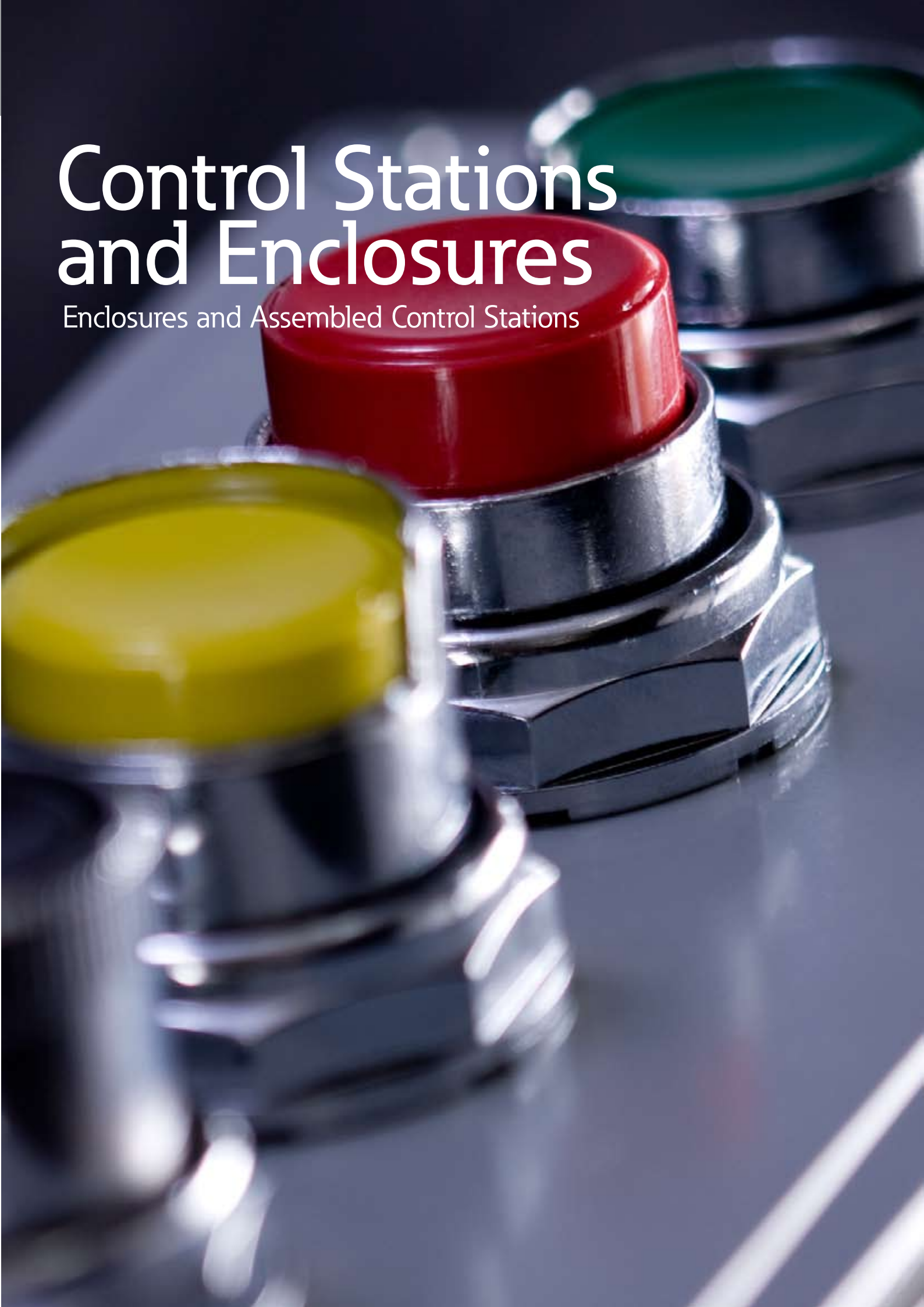

Diecast Aluminium Enclosures



Standard		
Number of Holes	Single - Depth	Double -Depth
1	TN1	TN11
2	TN2	TN12
3	TN3	TN13
4	TN4	TN14
6	-	TN15



Corrosion Resistant		
Number of Holes	Single - Depth	Double -Depth
1	E34N1	E34N11
2	E34N2	E34N12
3	E34N3	E34N13
4	E34N4	E34N14

1-2 hole: 3/4 inch conduit entry hole, 2-6 hole: 1 inch conduit bottom-entry hole, 1.5 inch UNF Thread

Stainless Steel Enclosures



Stainless Steel		
Number of Holes	316 Stainless	304 Stainless
1	EP0130SS	10250TN33
2	EP0230SS	10250TN34
3	EP0330SS	10250TN35
4	EP0430SS	10250TN36

316: 25mm non-threaded conduit bottom-entry hole, IP67

304: 1-2 hole: 3/4 inch conduit entry hole, 2-4 hole: 1 inch conduit bottom-entry hole, 1.5 inch UNF Thread, IP66

Fibreglass Enclosures



Fibreglass	
Number of Holes	Cat. No
1	TFG11
2	TFG12
3	TFG13

20mm non-threaded conduit bottom-entry hole
IP66, UV Stabilised.

Assembled Control Stations



Push-Pull Stop Stations (Non-Padlockable)		
Operator Head	Contacts	Cat No.
Metal mushroom	1LONC	10250T700M
	1ECNO,1LONC	10250T701M
Metal palm	1LONC	10250T700P
	1ECNO,1LONC	10250T701P



"Staylock" Push-Pull Stop Stations (Non-Padlockable)			
Operator Head	Contacts	Padlock Included	Cat. No
45mm metal mushroom	1LONC	NO	ESM9/5
	1LONC	YES	ESM9/5P
	1ECNO,1LONC	NO	ESM9/6
	1ECNO,1LONC	YES	ESM9/6P
63.5mm metal palm	1LONC	NO	ESP6/5
	1LONC	YES	ESP6/5P
	1ECNO,1LONC	NO	ESP6/6
	1ECNO,1LONC	YES	ESP6/6P



Stop Start Pushbutton Station	
Description	Cat. No
Fibreglass Enclosure Start: green pushbutton with boot Stop: red padlockable mushroom with boot	T3500

A close-up, low-angle shot of a highly reflective, metallic surface, likely stainless steel. The surface is perforated with several circular holes of varying sizes. The lighting is bright, creating strong highlights and deep shadows that emphasize the texture and curvature of the metal. The overall color palette is a cool, blue-tinted silver.

Accessories

Padlock attachments, boots, shrouds and hardware

Padlock Attachments and Boots



Padlock Attachment Accessories		
Padlock Attachments	Description	Cat. No
With hinged transparent flap. For flush or extended pushbuttons, and knob-operated selector switches.	Plastic Cover	TA38
For flush stop button. Permits locking NC contacts in open position with padlock. Prevents operation of button. Will not lock NO contact.	Chrome	TA2
	Corrosion Resistant	E34TA2
For extended pushbutton. Permits locking NC contacts in open position with padlock.	Chrome	TA26
For illuminated pushbuttons. Locks in down position only.	Chrome	10250TA64
For non-illuminated knob selector switches. Provisions for up to 5 padlocks.	Chrome	10250TA11
	Corrosion Resistant	E34TA11

Boots		
Boots	Colour	Cat. No
Protective boot for flush pushbutton operators	Clear	TA46
	Black	TA47
	Red	TA48
	Green	TA49
	Yellow	TA50
Protective boot for extended pushbutton operators	Black	TA3
	Red	TA4
	Green	TA10
	Clear	TA85
Protective boot for illuminated pushbuttons	Clear	TA25
Protective boot for momentary mushroom operators on pages 6-7. Not suitable for use with T140 operator.	Black	TA88

Shrouds and Guards



Shrouds and Guards		
Title	Description	Cat. No
Shroud for Mushroom Head Operator	Prevents accidental operation. Not for push-pull operators. Momentary operators only	10250TA6 E34TA6
Extended Retaining Nut	Replaces standard nut and provides guard for flush head pushbutton operators.	10250TA12 E34TA12
Guard for Illuminated Pushbutton	Guard for Illuminated Pushbutton	10250TA15 E34TA15*
Shroud	For jumbo mushroom head operator. Available in Grey Yellow (Not for push-pull operators, momentary operators only.)	TA56 10250TA56Y
Half Shroud – Yellow	For jumbo mushroom head operator.	10250ED1241

Hardware and Kits

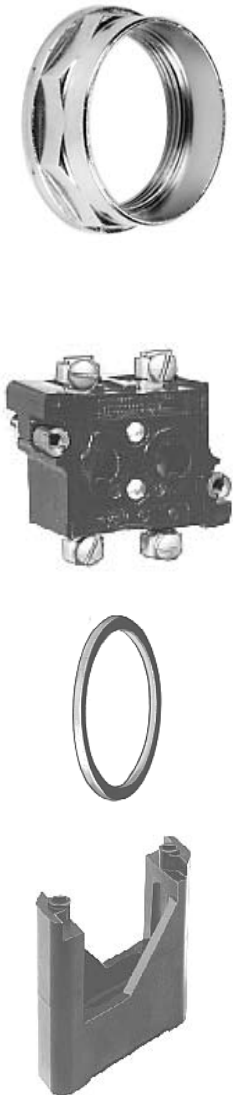

Hardware and Kits		
Title	Description	Cat. No
Fingerproof Shroud	10 per Package Fits new style contact blocks and light units.	10250TA101
Special Retaining Nut to accommodate thick panel	For indicating lights: Chrome Corrosion Resistant	10250TA30 E34TA30
	Press test, pushbuttons and selector switches: Chrome Corrosion Resistant	10250TA31 E34TA31
Terminal Block	Two terminals. Each will accommodate two wire terminations.	10250TA62
Spacer Ring	Used when legend plate is not required. Set of 5	TA8
Base Mounting Spacers	Equivalent to contact block in depth — Complete with screws, washers, etc. For use in pushbutton stations for base mounting contact blocks. 1 Block Deep 2 Blocks Deep	TA22 TA23
Contact Block Tape Seals	Seals plunger openings on last contact block. Order in multiples of 10 pieces.	10250TK5

Special Operators and Attachments

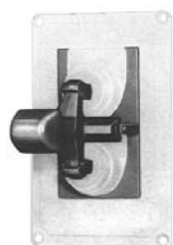

Special Operators and Attachments		
Title	Description	Cat. No
Wobble Stick	Complete with retaining nut — fits standard button.	TA5
Lever Operator	For use with two vertically mounted flush pushbuttons.	10250TA14
Maintained Contact Attachment Release Button Assembly	Mechanically interlocks with another pushbutton and contact block (not included). Provides mode indication. Minimum hole centres 41.1 mm, maximum 58.8 mm Black Red Green Yellow Same with Long Button — Black	10250TA17 10250TA18 10250TA19 10250TA20 10250TA39
Maintained Contact Attachment	Mechanically interlocks two buttons and provides position indication for one. Use with two pushbutton operators and one or more contact blocks.	TA1

Hole Plugs and Tools



Hole Plugs		
Title	Description	Cat. No
Plug	For unused holes — Steel, painted gray	10250TA7
Stainless Steel Plug	For unused holes — Stainless Steel - Square	E30KT5



Tools		
Title	Description	Cat. No
Octagonal Tool	Octagonal notched to fit over selector switch lever	10250TA95
Tool for Tightening Boots	Used to install boot	TA96
Allen Key	Used for removal of jumbo mushroom head.	10250TA102

Special Light Modules



Special Light Modules		
Title	Description	Cat. No
Master Test (Dual Input) Module	Internal Form C relay suitable for either AC or DC applications. Total electrical isolation between monitored and test circuit.	10250TMT8
Flasher Module	Changes any AC illuminated device to a controlled flashing light. 24V 120V	TFL2 TFL1

A close-up, high-angle photograph of a dark, metallic gear. The gear has a central hole with a shaft passing through it. The gear's teeth are visible on the right side, and the surface shows fine, concentric machining lines. The lighting is dramatic, with strong highlights and deep shadows, emphasizing the texture and form of the metal.

Technical Data

Illuminated Pushbuttons & Indicating Lights

Pushbutton Dimensions

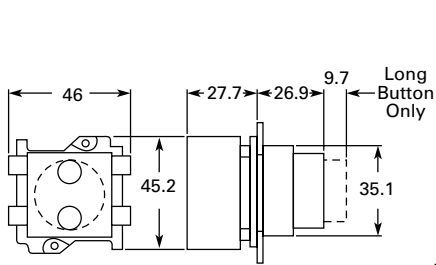

Flush and Long Pushbutton
Half Shroud Is Same as Long Pushbutton
with Lower Half of Guard Ring Cut Back

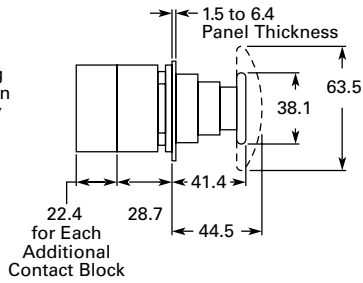

Mushroom and Jumbo Head Pushbutton

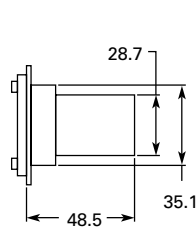

Pushbutton with Cylinder Lock

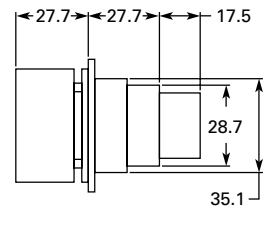

Illuminated Pushbutton

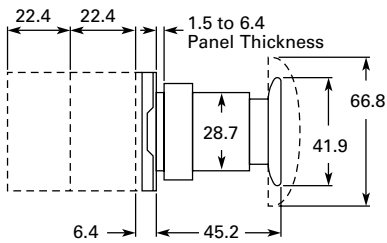

Push-Pull Switch

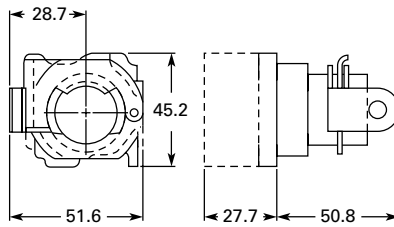

Flush Pushbutton Operator with Padlock Attachment

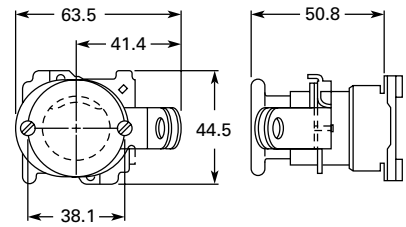

Mushroom Head Pushbutton Operator with Padlock Attachment

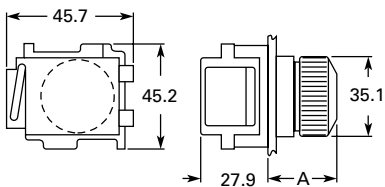

Indicating Light - Transformer Type

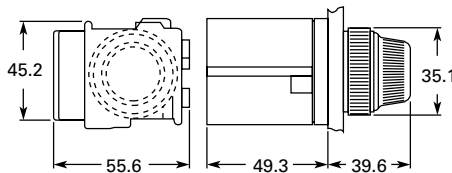

Press-To-Test Indicating Light - Transformer Type

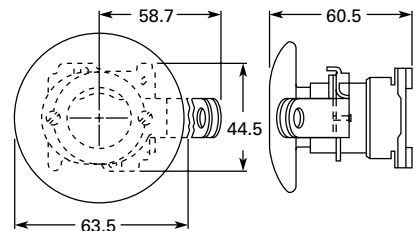

Jumbo Mushroom Head Pushbutton Operator with Padlock Attachment

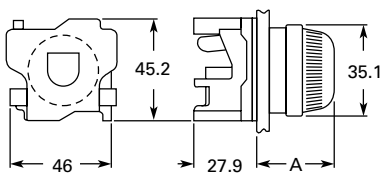

Indicating Light - Resistor and Neon Type

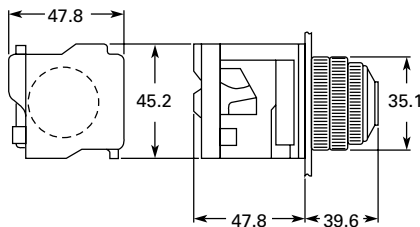

Press-To-Test Indicating Light - Resistor Type

Lens	Dimension A
Plastic	35.1
Glass	39.6

Approximate Dimensions in mm

Pushbutton Dimensions

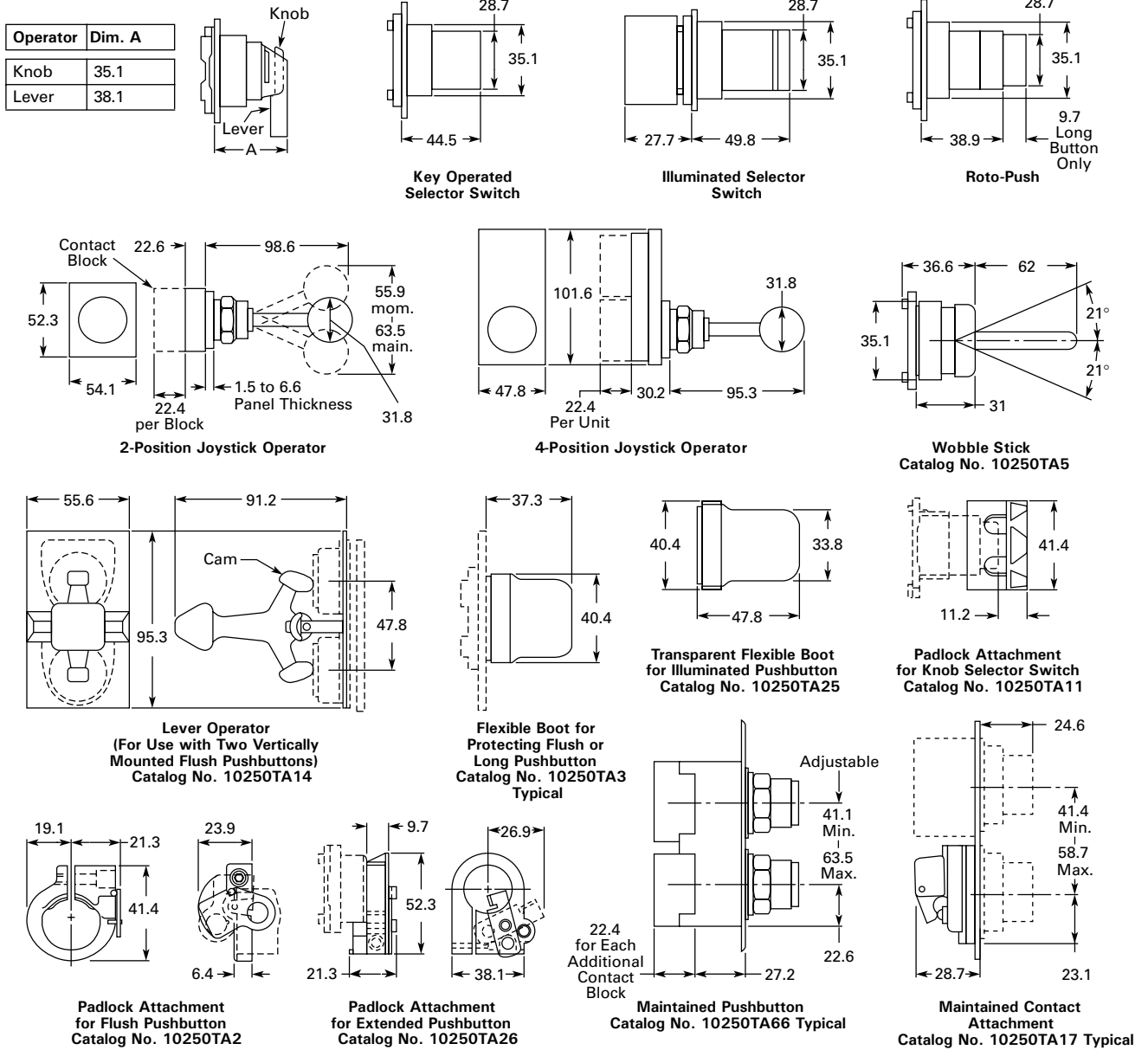

Approximate Dimensions in mm

Diecast Aluminium Enclosure Dimensions				
	Wide	High	Single Depth	Double Depth
1	98.6	101.6	57.2	76.3
2	98.6	149.4	57.2	76.3
3	98.6	196.9	57.2	76.3
4	98.6	244.6	57.2	76.3

304 Stainless Steel Enclosure Dimensions			
	Wide	High	Deep
1	76.2	88.9	76.2
2	88.9	171.5	76.2
3	88.9	228.6	76.2
4	88.9	285.8	76.2

Fibreglass Enclosure Dimensions			
	Wide	High	Deep
1	97	100	75
2	97	150	75
3	97	200	75

316 Stainless Steel Enclosure Dimensions			
	Wide	High	Deep
1	120	120	84
2	120	160	84
3	120	220	84
4	120	280	84



Powering Business Worldwide

Pushbutton Dimensions

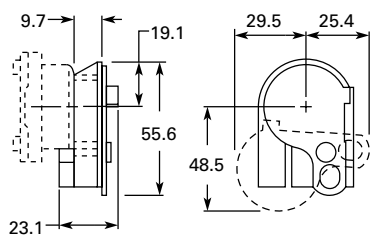

Padlock Cover Guard for Flush Pushbutton
Catalog No. 10250TA36

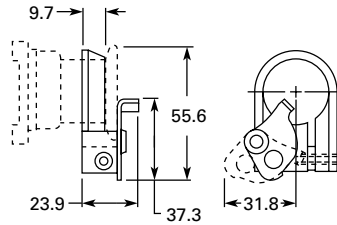

Padlock Attachment for Maintained Push-Pull Operator
Catalog No. 10250TA64

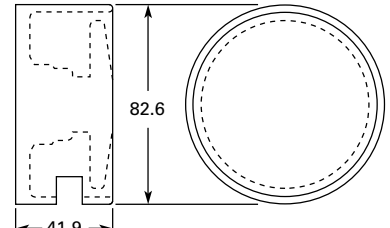

Protecting Shroud for Jumbo Mushroom Head Button
Catalog No. 10250TA56

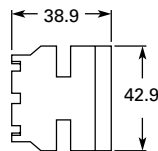

Protecting Shroud for Mushroom Head Button
Catalog No. 10250TA6

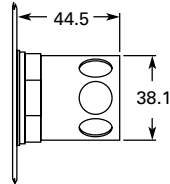

Protecting Shroud for Illuminated Pushbutton
Catalog No. 10250TA15

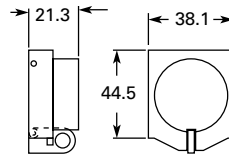

Padlock Hasp or Flip-Up Guard
Catalog No. TA38

Terminals on Top

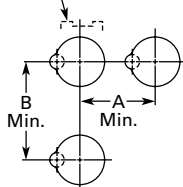

Horizontal Rows

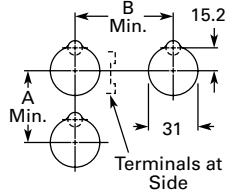

Vertical Rows

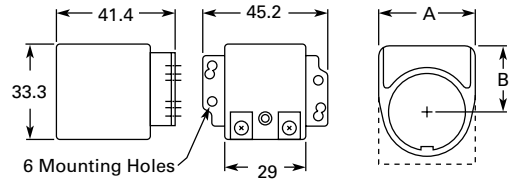

Master Test Module, Flasher Module

Legend Plate

Panel Drilling and Minimum Spacing

Legend Plate	Dim. in mm	
	A Min.	B Min.

1 or 2 Circuit Contact Blocks

Small or None	41.4	57.2
Standard	44.5	57.2
Jumbo ①	57.2	57.2
Extra Large	63.5	66

4 Circuit Contact Block 10250T44

Small or None	47.8	57.2
Standard	47.8	57.2
Jumbo ①	57.2	57.2
Extra Large	63.5	66

① If Jumbo plates are to be placed one above the other vertically, add 3.3 to minimum dimensions listed.

Note: Locating nib hole or notch is 3.45 – 3.56 mm #29 drill.

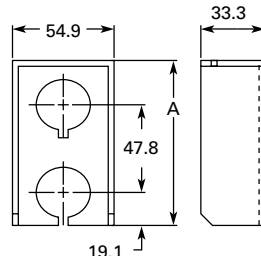

Multiple Button Guard

Number of Elements	Dimension A
2	101.6
3	149.4
4	200.2
7	339.9

Legend Plate	Dim. in mm	
	A	B

1/2 Round Legend Plates

Small	39.6	23.1
Standard	40.4	27.2
Jumbo	52.3	38.9

Square Legend Plates

Small	40.4 Sq.	22.9
Standard	44.5 Sq.	26.9 ②
Jumbo	55.6 Sq.	38.1
Extra Large	62.0 Sq.	41.4

② For plastic legend plate, Dimension B is 28.4

Enclosure Size (No. of Elements)	Dimensions in Inches (mm)				
	Wide A	High B	Deep C	Mounting	
				D	E
2, 3, & 4	95.3	49.3	3.3	68.3	35.1
6 & 7	101.6	55.6	3.3	73.2	41.4

Approximate Dimensions in mm

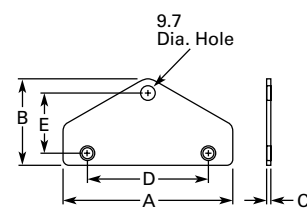

Chain Hook Bracket

Technical Data

Features

- Heavy-duty zinc die cast construction
- Enclosed silver contacts with reliability nibs
- Diaphragm seals with drainage holes
- Grounding nibs on the operator casing

Benefits

- Reliability nibs improve contact reliability even under dry circuit and fine dust conditions
- Drainage holes prevent buildup of liquid inside the operator which can prevent operation in freezing environments
- Grounding nibs bite through paint and other coatings to provide secure ground

Contact Operation

Slow make and break. All normally closed contacts have positive opening operation, i.e., normally closed contacts are forced open in the event of contact weld or spring breakage.

Standards and Certifications

- CE EN60947-5-1
- UL 508 — File No. 131568
- CSA C22.2 No. 14 — File No. LR68551

Ingress Protection

When mounted in similarly rated enclosure —

- Standard Indicating Lights
 - UL (NEMA) Type 1, 2, 3, 3R, 3S, 4, 4X, 12, 13
 - IEC IP65
- All Other Operators
 - UL (NEMA) Type 1, 2, 3, 3R, 4, 4X, 12, 13
 - IEC IP65

Technical Data and Specifications

Mechanical Ratings

- Frequency of operation
 - All pushbuttons: 6000 operations/hr.
 - Key and lever selector switches: 3000 operations/hr.
 - Auto-latch devices: 1200 operations/hr.

- Life
 - Pushbuttons: 10 x 10⁶ operations
 - Contact blocks: 10 x 10⁶ operations
 - PresTest units: 10 x 10⁶ operations
 - Lever and key selector switches: 0.25 x 10⁶ operations
 - Twist to release pushbuttons: 0.3 x 10⁶ operations
- Shock resistance
 - Duration: 20 mS ≥ 5g

Climate Conditions

- Operating Temperature: (-17° to 66°C)
- Storage Temperature: (-40° to 80°C)
- Altitude: 2,000m (6,562 ft.)
- Humidity: Max. 95% RH @ 60°C

Terminals

- Marking
 - NC-NO on the contact block to meet the NEMA requirements. Dual marking system 1 – 2 for normally closed, 3 – 4 for normally open to meet BS5472 (Cenelec EN50 005)
- Clamps
 - Terminals are saddle clamp type for 1 x 22 AWG (0.34 mm²) to 2 x 14 AWG (2.5 mm²) conductors
- Torque = 7 lb-in (0.8 Nm)
- Degree of protection against direct electrical contact: IP2X with fingerproof shroud

Light Units

- Transformers: will withstand short circuit for 1 hour per IEC 60997-5-1
- Bulbs — average life
 - Transformer type: 20,000 hrs.
 - Resistor/direct voltage type: 2500 hrs. minimum @ rated V
 - LED: 60,000 to 100,000 hrs.

Contact Block

Meet or Exceed NEMA Rating Designations A600, A300 and B300 for AC and P600 for DC							
Description	Volts AC 50 or 60 Hz				Volts DC		
	120	240	480	60	24	125	250
Make and Emerg. Interrupting Capacity (Amp)	60	30	15	12	5.7	1.1	0.55
Normal Load Break (Amp)	6	3	1.5	1.2	5.7	1.1	0.55
Thermal Current (Amp)	10	10	10	10	5.0	5.0	5.0
Voltamperes (VA):							
Make and Emerg. Interrupting Capacity	7200	7200	7200	7200	138	138	138
Normal Load Break	720	720	720	720	138	138	138

Electrical Ratings

- Insulation: Ui = 660V AC or DC
- Thermal: Ith = 10A

Short Circuit Coordination to IEC/EN 60947-5-1

- Rated conditional short circuit current: 1 kA
- Fuse type: GE Power Controls TIA 10, Red Spot Type gG, 10A, 660V AC, 460V DC, BS88-2, IEC 60269-2-1

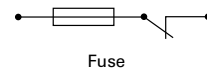

- UL rating: A600, P600
 - AC load life duty cycle 1200 operations/hour
 - 10A: 110V pf 0.4 – 1 x 10⁶ operations
 - 5A: 250V pf 0.4 – 1 x 10⁶ operations
 - 2A: 660V pf 0.4 – 1 x 10⁶ operations
- Switching capacity
 - AC15 rated make/break (11 x Ie at 1.1 x Ue)
 - 6A: 120V pf 0.3
 - 4A: 240V pf 0.3
 - 2A: 660V pf 0.3
 - DC13 rated make/break (1.1 x Ie at 1.1 x Ue)
 - 1.0A: 125V L/R ≥ 0.95 at 300 mS
 - .55A: 250V L/R ≥ 0.95 at 300 mS
 - .1A: 660V L/R ≥ 0.95 at 300 mS
 - 10A: 110V pure resistive
- Maximum ratings for logic level and hostile atmosphere application
 - Maximum amperes: 0.5A
 - Maximum volts: 120V AC/DC



Powering Business Worldwide



Take Control

22.5mm Modular Pushbuttons

Rugged and Reliable

Eaton's M22 Titan 22.5mm industrial heavy-duty pushbutton line offers a wide array of functional, attractive and ergonomically designed illuminated and non-illuminated pushbuttons, selector switches, push-pulls, alternate action and twist-to-release operators. The complete illuminated line is only offered in LED light units to ensure

high-quality brightness and up to 100,000 hours of LED illumination. The space-saving modular construction of the 22.5mm line makes on-the-job assembly fast and simplifies the stocking of both components and complete devices.

For more information visit:
www.eatonelectric.com.au

EATON

Powering Business Worldwide

Eaton Corporation is a diversified power management company ranked among the largest Fortune 500 companies. The electrical group is Eaton's largest division and is a global leader in electrical control, power distribution, power quality, automation, and monitoring products and services. Eaton's global electrical brands, including Cutler-Hammer®, MGE Office Protection Systems™, Powerware®, Holec®, MEM®, Santak and Moeller, provide customer-driven PowerChain Management® solutions to serve the power system needs of the industrial, institutional, government, utility, commercial, residential, IT, mission critical and OEM markets worldwide.

PowerChain Management solutions help enterprises achieve sustainable and competitive advantages through proactive management of the power system as a strategic, integrated asset throughout its life cycle. With Eaton's distribution, generation and power quality equipment; full-scale engineering services; and information management systems, the power system is positioned to deliver powerful results, greater reliability, operating cost efficiencies, effective use of capital, enhanced safety, and risk mitigation.

PowerChain
Management®

Eaton Industries Pty. Ltd.
Electrical Group
10 Kent Road Mascot,
NSW 2020 Australia
1300 3 EATON (1300 3 332 866)
www.eatonelectric.com.au
www.powerware.com.au

PowerChain Management is a trademark of Eaton Corporation. All other trademarks are property of their respective owners.

EATON

©2008 Eaton Corporation
All Rights Reserved
Printed in AUS
July 2008