

Accessories
Permanent Magnet
DM-Q12

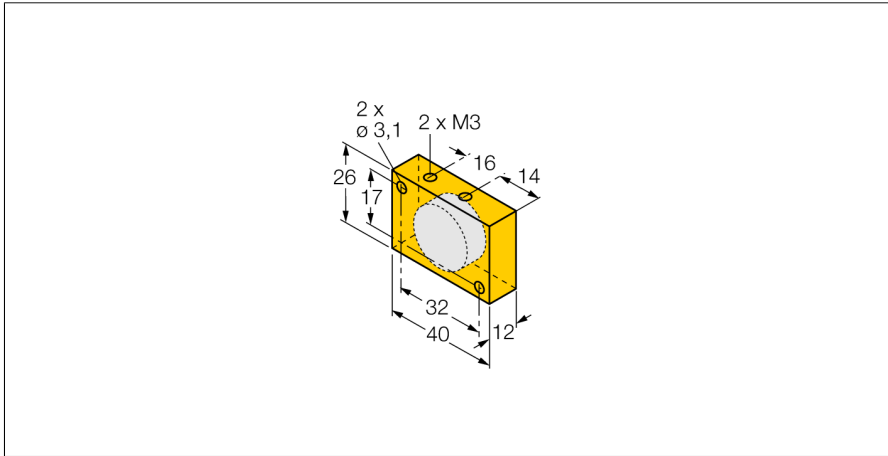

- **Attainable switching distance 58 mm with magnetic field sensors (BIM) in models (E)M12E, M18 and G12SK**
- **Attainable switching distance 49 mm with magnetic field sensors (BIM) in models EH6.5, EG08 and M12-S1209**

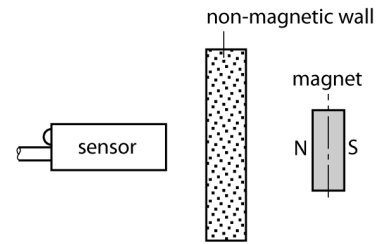

Type designation	DM-Q12
Ident-No.	6900367
Dimensions	40 x 26 x 12 mm

Functional principle

Magnetic-inductive proximity switches are actuated by magnetic fields. They detect permanent magnets through non-ferromagnetic materials such as wood, plastic, non-ferrous metals, aluminum or stainless steel.

Turck magnetic field sensors obtain a particularly high switching distance using the actuation magnets. As they are available in a number of sizes and versions, they enable a wide range of possibilities for detection, particularly in constructions where mounting space is limited or other difficult conditions prevail.

The diagram shows a typical characteristic curve of the magnetic flux density [in mT] based on the distance in the axial direction and at room temperature.