

DO NOT SCALE DRAWING

REVISION

A INITIAL DRAWING 17.9.15

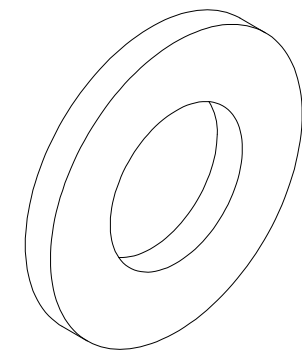
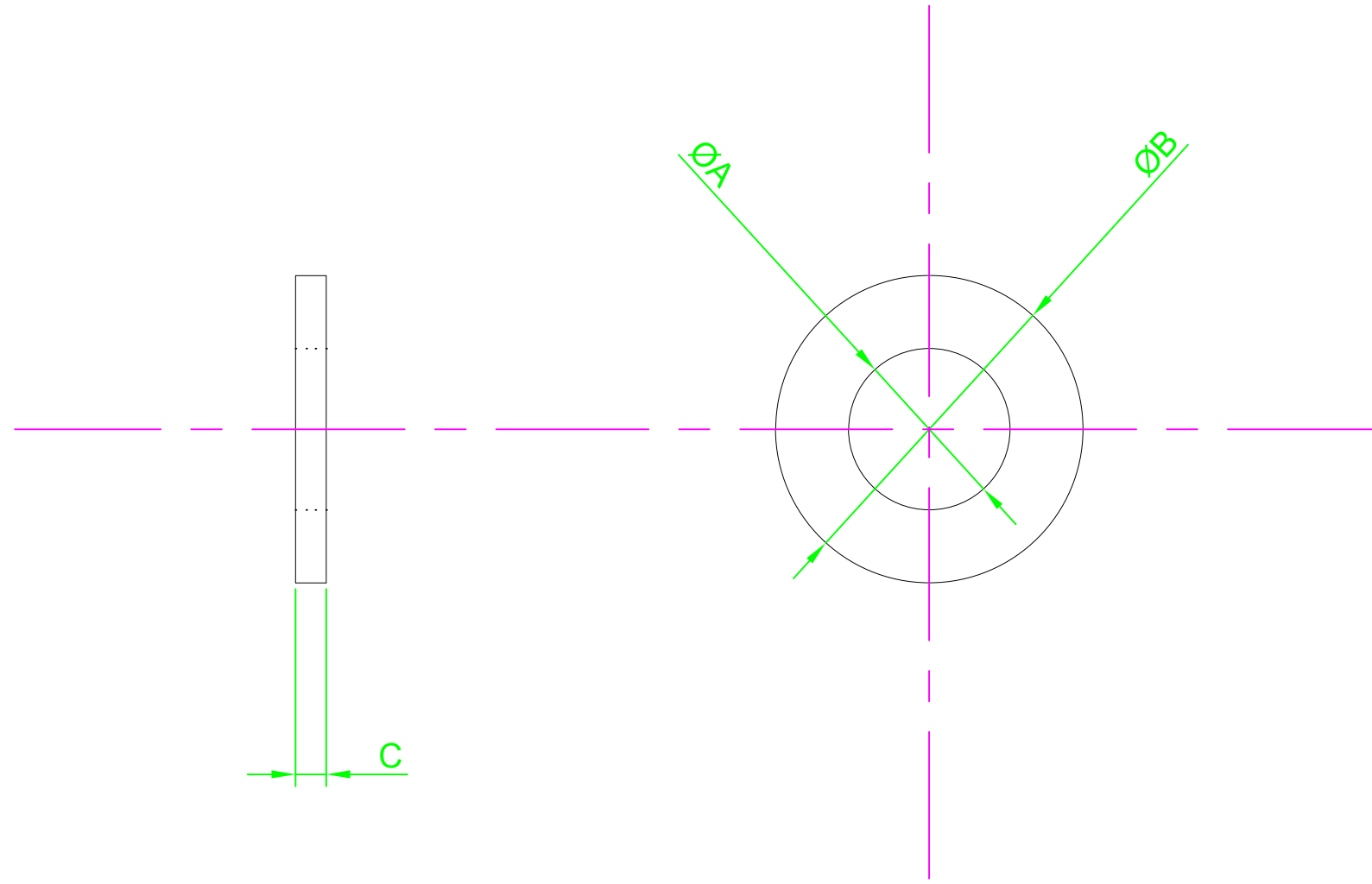

Part Number	Size	ØA Ref	ØB Ref	C Ref
DM2.5 - PWFI- BG10	M2.5	2.8	6.5	0.5
DM3 - PWFI- BG10	M3	3.4	7.0	0.5
DM4 - PWFI- BG10	M4	4.4	9.0	0.8
DM5 - PWFI- BG10	M5	5.4	10.0	0.8
DM6 - PWFI- BG10	M6	6.4	12.5	0.8
DM8 - PWFI- BG10	M8	8.4	17.0	1.5
DM10 - PWFI- BG10	M10	10.4	21.0	1.5
DM12 - PWFI- BG10	M12	12.5	24.0	1.5

NOTES:



UNLESS OTHERWISE SPECIFIED:
DIMENSIONS ARE IN MM (MILLIMETERS).
SURFACE FINISH:
TOLERANCES:

	NAME	DATE
DRAWN	Darryl Wilson	17.09.15
CHK'D		
APPVD		

MATERIAL:
VULCANISED FIBRE

HEAT TREATMENT:
N/A

TITLE:
Fibre Washer

DESIGN RIGHT. TR FASTENINGS LTD, 2003
UNDER NO CIRCUMSTANCES MUST THIS
DRAWING BE COPIED OR DISCLOSED
WITHOUT FIRST OBTAINING WRITTEN
AUTHORITY.

CUSTOMER PART NUMBER:
N/A

FINISH:
RED

DRAWING NUMBER:
DMXX-PWFI-BG10

A4