



MICROCHIP

**PIC32MK General Purpose (GP)
Development Board User's Guide**

Note the following details of the code protection feature on Microchip devices:

- Microchip products meet the specification contained in their particular Microchip Data Sheet.
- Microchip believes that its family of products is one of the most secure families of its kind on the market today, when used in the intended manner and under normal conditions.
- There are dishonest and possibly illegal methods used to breach the code protection feature. All of these methods, to our knowledge, require using the Microchip products in a manner outside the operating specifications contained in Microchip's Data Sheets. Most likely, the person doing so is engaged in theft of intellectual property.
- Microchip is willing to work with the customer who is concerned about the integrity of their code.
- Neither Microchip nor any other semiconductor manufacturer can guarantee the security of their code. Code protection does not mean that we are guaranteeing the product as "unbreakable."

Code protection is constantly evolving. We at Microchip are committed to continuously improving the code protection features of our products. Attempts to break Microchip's code protection feature may be a violation of the Digital Millennium Copyright Act. If such acts allow unauthorized access to your software or other copyrighted work, you may have a right to sue for relief under that Act.

Information contained in this publication regarding device applications and the like is provided only for your convenience and may be superseded by updates. It is your responsibility to ensure that your application meets with your specifications. MICROCHIP MAKES NO REPRESENTATIONS OR WARRANTIES OF ANY KIND WHETHER EXPRESS OR IMPLIED, WRITTEN OR ORAL, STATUTORY OR OTHERWISE, RELATED TO THE INFORMATION, INCLUDING BUT NOT LIMITED TO ITS CONDITION, QUALITY, PERFORMANCE, MERCHANTABILITY OR FITNESS FOR PURPOSE. Microchip disclaims all liability arising from this information and its use. Use of Microchip devices in life support and/or safety applications is entirely at the buyer's risk, and the buyer agrees to defend, indemnify and hold harmless Microchip from any and all damages, claims, suits, or expenses resulting from such use. No licenses are conveyed, implicitly or otherwise, under any Microchip intellectual property rights unless otherwise stated.

Microchip received ISO/TS-16949:2009 certification for its worldwide headquarters, design and wafer fabrication facilities in Chandler and Tempe, Arizona; Gresham, Oregon and design centers in California and India. The Company's quality system processes and procedures are for its PIC® MCUs and dsPIC® DSCs, KEELoQ® code hopping devices, Serial EEPROMs, microperipherals, nonvolatile memory and analog products. In addition, Microchip's quality system for the design and manufacture of development systems is ISO 9001:2000 certified.

**QUALITY MANAGEMENT SYSTEM
CERTIFIED BY DNV
= ISO/TS 16949 =**

Trademarks

The Microchip name and logo, the Microchip logo, AnyRate, AVR, AVR logo, AVR Freaks, BeaconThings, BitCloud, CryptoMemory, CryptoRF, dsPIC, FlashFlex, flexPWR, Heldo, JukeBlox, KEELoQ, KEELoQ logo, Klear, LANCheck, LINK MD, maXStylus, maXTouch, MediaLB, megaAVR, MOST, MOST logo, MPLAB, OptoLyzer, PIC, picoPower, PICSTART, PIC32 logo, Prochip Designer, QTouch, RightTouch, SAM-BA, SpyNIC, SST, SST Logo, SuperFlash, tinyAVR, UNI/O, and XMEGA are registered trademarks of Microchip Technology Incorporated in the U.S.A. and other countries.

ClockWorks, The Embedded Control Solutions Company, EtherSynch, Hyper Speed Control, HyperLight Load, IntelliMOS, mTouch, Precision Edge, and Quiet-Wire are registered trademarks of Microchip Technology Incorporated in the U.S.A.

Adjacent Key Suppression, AKS, Analog-for-the-Digital Age, Any Capacitor, AnyIn, AnyOut, BodyCom, chipKIT, chipKIT logo, CodeGuard, CryptoAuthentication, CryptoCompanion, CryptoController, dsPICDEM, dsPICDEM.net, Dynamic Average Matching, DAM, ECAN, EtherGREEN, In-Circuit Serial Programming, ICSP, Inter-Chip Connectivity, JitterBlocker, KlearNet, KlearNet logo, Mindi, MiWi, motorBench, MPASM, MPF, MPLAB Certified logo, MPLIB, MPLINK, MultiTRAK, NetDetach, Omniscient Code Generation, PICDEM, PICDEM.net, PICKit, PICtail, PureSilicon, QMatrix, RightTouch logo, REAL ICE, Ripple Blocker, SAM-ICE, Serial Quad I/O, SMART-I.S., SQT, SuperSwitcher, SuperSwitcher II, Total Endurance, TSHARC, USBCheck, VariSense, ViewSpan, WiperLock, Wireless DNA, and ZENA are trademarks of Microchip Technology Incorporated in the U.S.A. and other countries.

SQTP is a service mark of Microchip Technology Incorporated in the U.S.A.

Silicon Storage Technology is a registered trademark of Microchip Technology Inc. in other countries.

GestIC is a registered trademark of Microchip Technology Germany II GmbH & Co. KG, a subsidiary of Microchip Technology Inc., in other countries.

All other trademarks mentioned herein are property of their respective companies.

© 2017, Microchip Technology Incorporated, All Rights Reserved.

ISBN: 978-1-5224-1790-3

Object of Declaration: PIC32MK GP Development Board User's Guide

EU Declaration of Conformity

This declaration of conformity is issued by the manufacturer.

The development/evaluation tool is designed to be used for research and development in a laboratory environment. This development/evaluation tool is not a Finished Appliance, nor is it intended for incorporation into Finished Appliances that are made commercially available as single functional units to end users under EU EMC Directive 2004/108/EC and as supported by the European Commission's Guide for the EMC Directive 2004/108/EC (8th February 2010).

This development/evaluation tool complies with EU RoHS2 Directive 2011/65/EU.

This development/evaluation tool, when incorporating wireless and radio-telecom functionality, is in compliance with the essential requirement and other relevant provisions of the R&TTE Directive 1999/5/EC and the FCC rules as stated in the declaration of conformity provided in the module datasheet and the module product page available at www.microchip.com.

For information regarding the exclusive, limited warranties applicable to Microchip products, please see Microchip's standard terms and conditions of sale, which are printed on our sales documentation and available at www.microchip.com.

Signed for and on behalf of Microchip Technology Inc. at Chandler, Arizona, USA.

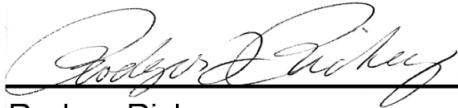

Rodger Richey
Director of Development Tools



Date

PIC32MK GP Development Board User's Guide

NOTES:



PIC32MK GP DEVELOPMENT BOARD USER'S GUIDE

Table of Contents

Preface	7
Chapter 1. Introduction	
1.1 Kit Contents	13
1.2 Kit Functionality and Features	14
Chapter 2. Hardware	
2.1 Hardware Features	17
Appendix A. Schematics	
A.1 Block Diagram	21
A.2 Schematics	22
Appendix B. Bill of Materials	
B.1 PIC32MK GP Development Board Bill of Materials	27
Worldwide Sales and Service	30

PIC32MK GP Development Board User's Guide

NOTES:

Preface

NOTICE TO CUSTOMERS

All documentation becomes dated, and this manual is no exception. Microchip tools and documentation are constantly evolving to meet customer needs, so some actual dialogs and/or tool descriptions may differ from those in this document. Please refer to our web site (www.microchip.com) to obtain the latest documentation available.

Documents are identified with a “DS” number. This number is located on the bottom of each page, in front of the page number. The numbering convention for the DS number is “DSXXXXXXXXA”, where “XXXXXXXX” is the document number and “A” is the revision level of the document.

For the most up-to-date information on development tools, see the MPLAB® IDE online help. Select the Help menu, and then Topics to open a list of available online help files.

INTRODUCTION

This chapter contains general information that will be useful to know before using the PIC32MK General Purpose (GP) Development Board. Items discussed in this chapter include:

- [Document Layout](#)
- [Conventions Used in this Guide](#)
- [Recommended Reading](#)
- [The Microchip Web Site](#)
- [Development Systems Customer Change Notification Service](#)
- [Customer Support](#)
- [Document Revision History](#)

DOCUMENT LAYOUT

This document describes how to use the PIC32MK General Purpose (GP) Development Board as a development tool to emulate and debug firmware on a target board. This user's guide is composed of the following chapters:

- **Chapter 1. “Introduction”** provides a brief overview of the starter kit, highlighting its features and functionality.
- **Chapter 2. “Hardware”** provides the hardware descriptions of the starter kit.
- **Appendix A. “Schematics”** provides a block diagram, board layouts, and detailed schematics of the starter kit.
- **Appendix B. “Bill of Materials”** provides the bill of materials for the components used in the design and manufacture of the starter kit.

CONVENTIONS USED IN THIS GUIDE

This manual uses the following documentation conventions:

DOCUMENTATION CONVENTIONS

Description	Represents	Examples
Italic characters	Referenced books	<i>MPLAB IDE User's Guide</i>
	Emphasized text	...is the <i>only</i> compiler...
Initial caps	A window	the Output window
	A dialog	the Settings dialog
	A menu selection	select Enable Programmer
Quotes	A field name in a window or dialog	"Save project before build"
Underlined, italic text with right angle bracket	A menu path	<u><i>File>Save</i></u>
Bold characters	A dialog button	Click OK
	A tab	Click the Power tab
Text in angle brackets < >	A key on the keyboard	Press <Enter>, <F1>
Plain Courier New	Sample source code	#define START
	Filenames	autoexec.bat
	File paths	c:\mcc18\h
	Keywords	_asm, _endasm, static
	Command-line options	-Opa+, -Opa-
	Bit values	0, 1
	Constants	0xFF, 'A'
<i>Italic Courier New</i>	A variable argument	<i>file.o</i> , where <i>file</i> can be any valid filename
Square brackets []	Optional arguments	mcc18 [options] <i>file</i> [options]
Curly brackets and pipe character: { }	Choice of mutually exclusive arguments; an OR selection	errorlevel {0 1}
Ellipses...	Replaces repeated text	var_name [, var_name...]
	Represents code supplied by user	void main (void) { ... }
Notes	A Note presents information that we want to re-emphasize, either to help you avoid a common pitfall or to make you aware of operating differences between some device family members. A Note can be in a box, or when used in a table or figure, it is located at the bottom of the table or figure.	Note: This is a standard note box.
		<div style="border: 2px solid black; padding: 5px; text-align: center;"> <p>CAUTION</p> <p>This is a caution note.</p> </div> <p>Note 1: This is a note used in a table.</p>

RECOMMENDED READING

This user's guide describes how to use the starter kit. The following Microchip documents are available and recommended as supplemental reference resources.

PIC32MK General Purpose Family Data Sheet (DM320106)

Refer to this document for detailed information on PIC32MK GP family devices. Reference information found in this data sheet includes:

- Device memory maps
- Device pinout and packaging details
- Device electrical specifications
- List of peripherals included on the devices

MPLAB® XC32 C/C++ Compiler User's Guide (DS50001686)

This document details the use of Microchip's MPLAB XC32 C/C++ Compiler to develop an application.

MPLAB® X IDE User's Guide (DS50002027)

Refer to this document for more information pertaining to the installation and implementation of the MPLAB X IDE software, as well as the MPLAB SIM Simulator software that is included with it.

Universal Serial Bus Specification and Associated Documents

The Universal Serial Bus is defined by the USB 2.0 specification and its associated supplements and class-specific documents. These documents are available from the USB Implementers Forum. See their web site at: <http://www.usb.org>

THE MICROCHIP WEB SITE

Microchip provides online support via our web site at <http://www.microchip.com>. This web site makes files and information easily available to customers. Accessible by most Internet browsers, the web site contains the following information:

- **Product Support** – Data sheets and errata, application notes and sample programs, design resources, user's guides and hardware support documents, latest software releases and archived software
- **General Technical Support** – Frequently Asked Questions (FAQs), technical support requests, online discussion groups, Microchip consultant program member listings
- **Business of Microchip** – Product selector and ordering guides, latest Microchip press releases, listings of seminars and events; and listings of Microchip sales offices, distributors and factory representatives

DEVELOPMENT SYSTEMS CUSTOMER CHANGE NOTIFICATION SERVICE

Microchip's customer notification service helps keep customers current on Microchip products. Subscribers will receive e-mail notification whenever there are changes, updates, revisions or errata related to a specified product family or development tool of interest.

To register, access the Microchip web site at www.microchip.com, click on Customer Change Notification and follow the registration instructions.

The Development Systems product group categories are:

- **Compilers** – The latest information on Microchip C compilers and other language tools
- **Emulators** – The latest information on the Microchip in-circuit emulator, MPLAB REAL ICE™
- **In-Circuit Debuggers** – The latest information on the Microchip in-circuit debugger, MPLAB ICD 3
- **MPLAB X IDE** – The latest information on Microchip MPLAB X IDE, the Windows® Integrated Development Environment for development systems tools
- **Programmiers** – The latest information on Microchip programmers including the PICkit™ 3 development programmer

CUSTOMER SUPPORT

Users of Microchip products can receive assistance through several channels:

- Distributor or Representative
- Local Sales Office
- Field Application Engineer (FAE)
- Technical Support

Customers should contact their distributor, representative or field application engineer (FAE) for support. Local sales offices are also available to help customers. A listing of sales offices and locations is included in the back of this document.

Technical support is available through the web site at: <http://support.microchip.com>

DOCUMENT REVISION HISTORY

Revision A (June 2017)

This is the initial released of this document.

NOTES:

Chapter 1. Introduction

Thank you for purchasing a Microchip Technology PIC32MK General Purpose (GP) Development Board . This development board provides a low-cost, modular development system for Microchip's line of 32-bit microcontrollers.

For a free Microchip demonstration code and additional information, visit the MPLAB Harmony page at: <http://www.microchip.com/MPLABHarmony>. The MPLAB Harmony Integrated Software Framework includes several demonstrations that have configurations for the PIC32MK GP Development Board.

These demonstrations are available in the <install-dir>/apps folder of the MPLAB Harmony installation, where <install-dir> is either:

C:/microchip/harmony/<version> (for Windows OS) or
~/microchip/harmony/<version> (for MAC or Linux OS).

For additional information on demonstrations and for building/running steps, refer to the documents available in the <install-dir>/doc folder.

This chapter covers the following topics:

- [Kit Contents](#)
- [Starter Kit Functionality and Features](#)

The preprogrammed example code on the PIC32MK GP family MCU is available for download from the Microchip web site at:

<http://www.microchip.com/design-centers/32-bit>. All project files are included, hence the code may be used to restore the PIC32MK GP family MCU on the starter kit to its original state (i.e., if the sample device has been reprogrammed with another program) or you can use the tutorial code as a platform for further experiment.

1.1 KIT CONTENTS

The PIC32MK General Purpose (GP) Development Board contains the following items:

- PIC32MK GP Development Board
- Micro-B USB cable to full-size Type-A cable, PIC32 USB cable to communicate with the PIC32 USB port

Note: If you are missing any part of a kit, contact a Microchip sales office for assistance. A list of Microchip offices for sales and service is provided on the last page of this document.

1.2 BLOCK DIAGRAM

Figure 1-1 illustrates the high-level block diagram of the PIC32MK GP Development Board.

FIGURE 1-1: PIC32MK GP DEVELOPMENT BOARD BLOCK DIAGRAM

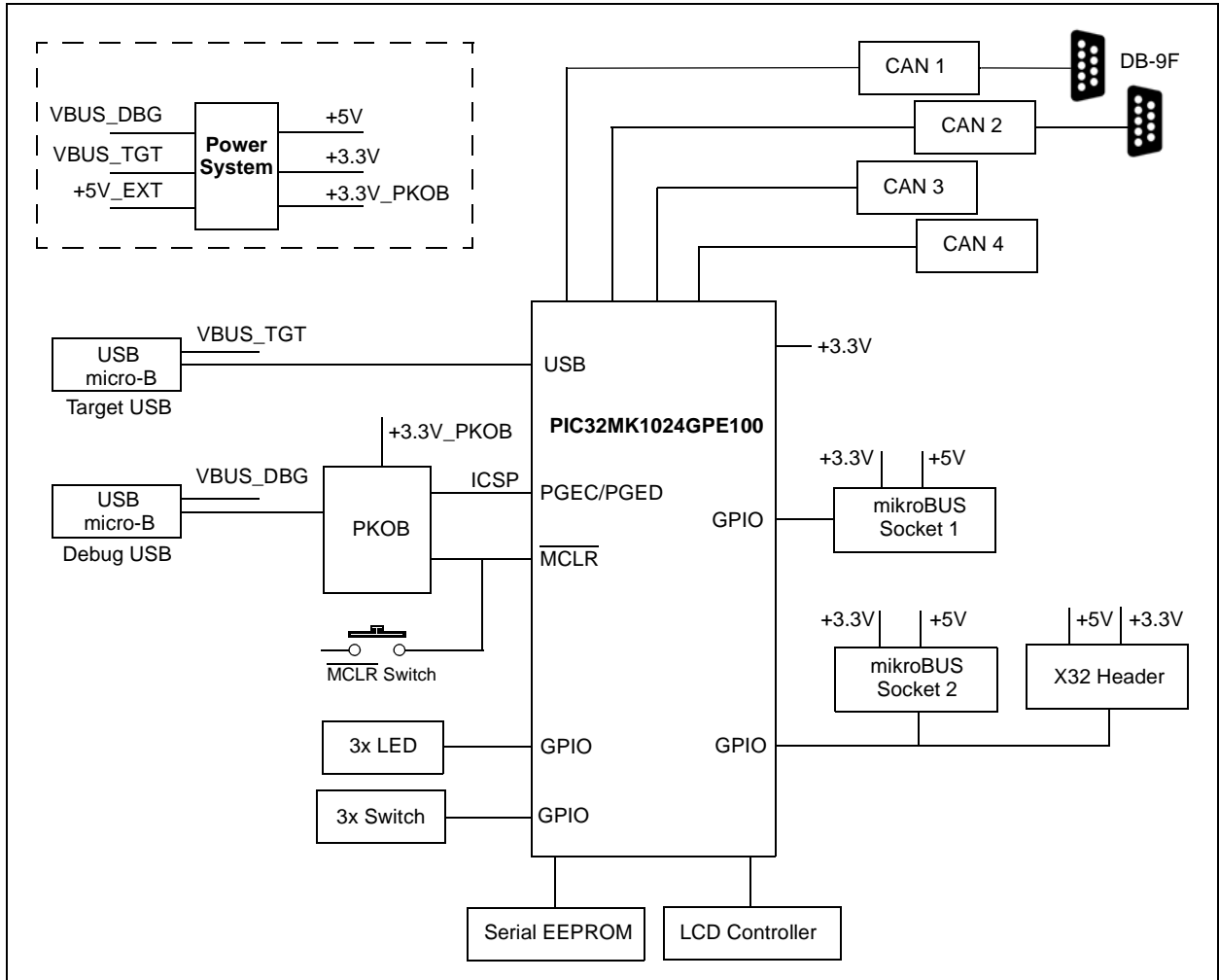

1.3 KIT FUNCTIONALITY AND FEATURES

1.3.1 Development Board

Representations of the layout of the development board included in the PIC32MK General Purpose (GP) Development Board are shown in [Figure 1-2](#) and [Figure 1-3](#).

The top assembly of the PIC32MK GP Development Board includes these key features, as indicated in [Figure 1-2](#):

1. PIC32MK1024GPE100
2. Green power indicator LED
3. Power diode shunt
4. Power in
5. In-Circuit Serial Programming™ (ICSP™) connection
6. USB Type-C connection
7. CAN 120 Ohm terminations
8. USB Type-A receptacle connectivity for PIC32 host-based applications
9. X32 header
10. Bus socket
11. Three user-defined switches
12. Three user-defined LEDs
13. DB-9F CAN connectors
14. CAN 3 & 4 header connectors.

For additional information about these features, refer to [Chapter 2. “Hardware”](#).

FIGURE 1-2: PIC32MK GP DEVELOPMENT BOARD LAYOUT (TOP VIEW)

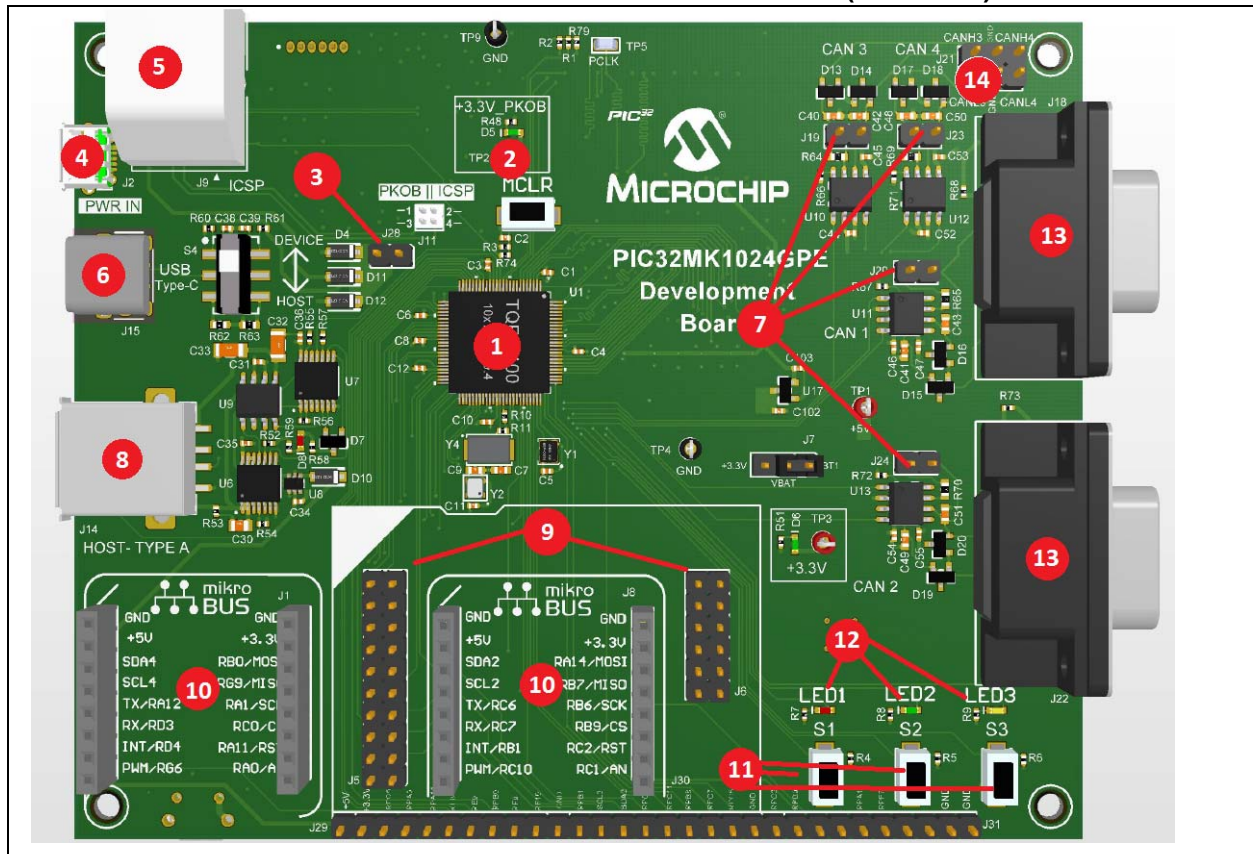

The bottom assembly of the PIC32MK GP Development Board includes these key features, as indicated in [Figure 1-3](#):

1. 50-pin LCD connector
2. SSD1963QL9 display controller
3. PIC24FJ256GB106 debug IC
4. Mini-USB 2.0 connector (debug)
5. USB Host and OTG power supply for powering PIC32 USB applications
6. Mini-USB 2.0 connector (OTG)

FIGURE 1-3: PIC32MK GP DEVELOPMENT BOARD LAYOUT (BOTTOM VIEW)

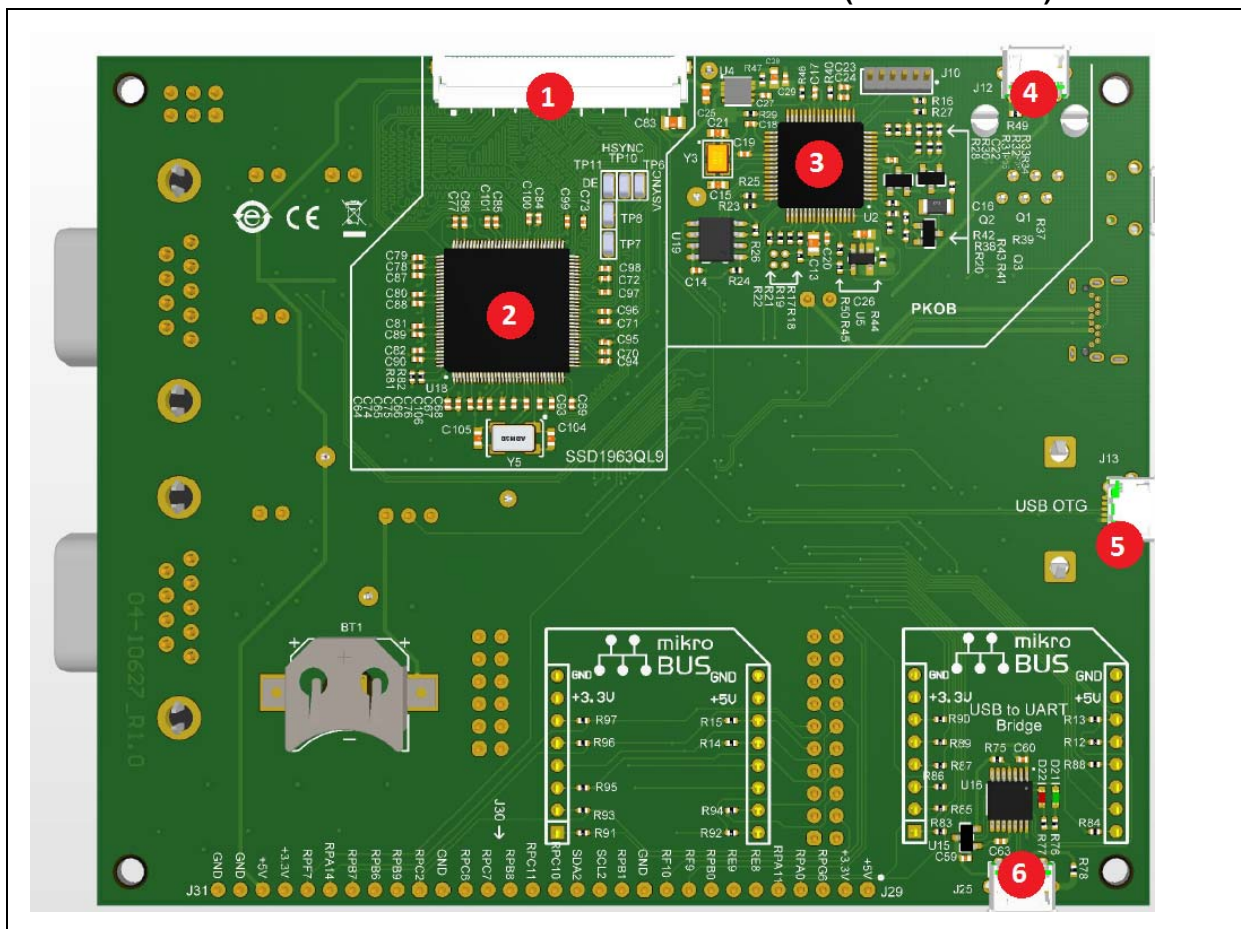

Chapter 2. Hardware

This chapter describes the hardware features of the PIC32MK General Purpose (GP) Development Board.

2.1 HARDWARE FEATURES

The following key features of the development board are presented in the order given in [Section 1.3 “Kit Functionality and Features”](#). See [Figure 1-2](#) for their locations on the development board.

2.1.1 Processor Support

The development board kit is designed with a permanently mounted (i.e., soldered) processor, PIC32MK1024GPE100.

2.1.2 Power Supply

Power is supplied to the development board by a USB bus power, which is connected to the USB debug connector J12.

One green LED (D6) is provided to indicate the PIC32 device is powered up.

2.1.3 Debug USB Connectivity

The development board includes a PIC24FJ256GB106 USB microcontroller that provides debugger connectivity over USB. The PIC24FJ256GB106 is hard-wired to the PIC32 device to provide protocol translation through the I/O pins of the PIC24FJ256GB106 to the ICSP pins of the PIC32 device.

If MPLAB REAL ICE or MPLAB ICD 3 is used with the starter kit, disconnect the on-board debugger from the PIC32 device by removing the jumper J11. When the on-board debugger is required, replace the jumper J11. When the jumper JP2 is installed, pin 1 must be connected to pin 3 and pin 2 must be connected to pin 4.

2.1.4 PIC32 USB Connectivity

There are three possible ways to connect to the PIC32 USB microcontroller:

- Host mode – Connect the device to the Type-A connector J14, which is located on the top of the starter kit. If using the Debug USB port to power the Host port, install the jumper JP1 to short the back-power prevention diode. A maximum of ~400 mA can be supplied from the Debug USB port to the Host port using this method. If the full 500 mA supply is needed, an external supply must be connected to the application board, and jumper J28 must be removed to prevent back-powering the Debug USB port.

- Device mode – Connect the debug mini-B USB cable to port J3 and then connect the starter kit to the host by using a cable with a Type-B micro-connector to the starter kit's micro-A/B port J4, which is located on the bottom of the board. The other end of the cable must have a Type-A connector. Connect the Type-A connector to a USB host. Jumper J28 should be removed.
- OTG mode – Connect the starter kit to the OTG device using an OTG micro-A/B cable to the micro-A/B port J13, which is located on the bottom of the board. The starter kit provides an on-board power supply capable of providing 120 mA Maximum. This supply is controlled by the PIC32MK1024GPE100 device. Jumper J28 should be removed.

2.1.5 Switches

Push button switches provide the following functionality:

- S1: Active-low switch connected to RG11
- S2: Active-low switch connected to RF13
- S3: Active-low switch connected to RF12
- /MCLR: Connected to Microcontroller /MCLR

These switches do not have any debounce circuitry and require internal pull-up resistors, this enables the user to investigate software debounce techniques. When Idle, the switches are pulled high (+3.3V), and when pressed, they are grounded.

2.1.6 LEDs

The LEDs, LED1 through LED3, are connected to the PORTG pins (RG12 through RG14) of the processor. The PORTG pins are set high to illuminate the LEDs.

2.1.7 Oscillator Options

A 12 MHz oscillator circuit (Y4) is connected to the on-board microcontroller. This oscillator circuit functions as the controller's primary oscillator.

Use of an external crystal or external oscillator is required to develop USB applications. The USB specification dictates a frequency tolerance of $\pm 0.05\%$ for high speed. Non-USB applications can use the internal oscillators.

The development board kit also has provisions for an external secondary 32 kHz oscillator (Y4); however, this is not populated. A suitable oscillator, ECS-3X8, can be obtained from Digi-Key: P/N - X801-ND CMR200TB32.768KDFTR.

The PIC24FJ256GB106 is independently clocked and has its own 12 MHz crystal.

2.1.8 mikroBUS™ Sockets

Two mikroBUS sockets, J1 and J8, are available on the development board. These sockets can be used to expand the functionality using the MikroElektronika Click adapter boards. The mikroBUS connector consists of two 1x8 female headers with SPI, I²C, UART, RST, PWM, analog, and interrupt lines as well as 3.3V, 5V, and GND power lines.

The GPIO pins for the mikroBUS sockets are assigned to route, as follows:

- UART1, I2C4, SPI1, and OC1 peripheral instances to mikroBUS socket J1
- UART2, I2C2, SPI2, and OC2 peripheral instances to mikroBUS socket J8

Note: UART2, I2C2, and SPI2 peripherals are also routed to the X32 audio header.

2.1.9 Audio Header

The PIC32MK GP Development Board includes two X32 headers, J5 and J6, to enable a connection to the Microchip Audio Codec Daughter Board. [Table 2-2](#) provides the details of the available Audio Codec Daughter Board, and for additional information, contact your local Microchip sales office.

For a complete list of currently available Audio Codec Daughter Boards, visit the microchipDIRECT web site (www.microchipdirect.com).

TABLE 2-1: AUDIO CODEC DAUGHTER BOARD

Daughter Board	Part No.
PIC32 Audio Coded Daughter Board	AC320100

2.1.10 Peripheral Resource Assignment

The MCU peripheral instances, assigned for different hardware interfaces, are provided in [Table 2-2](#). The correct peripheral instance must be used in the application to use the respective hardware interface.

TABLE 2-2: RESOURCE ASSIGNMENT

Resource Assignment	Peripheral					Reference Clock
	I ² C	SPI	UART	Output Compare	Interrupt	
MikroBus1 (J1)	I2C4	SPI1	UART1	OC1	INT1	—
MikroBus2 (J8)	I2C2	SPI2	UART2	OC2	INT2	—
X32 (J5, J6)	I2C2	SPI2	UART2	—	—	REFCLK

NOTES:

Appendix A. Schematics

A.1 SCHEMATICS

FIGURE A-1: PIC32MK GP DEVELOPMENT BOARD SCHEMATICS (1 OF 6)

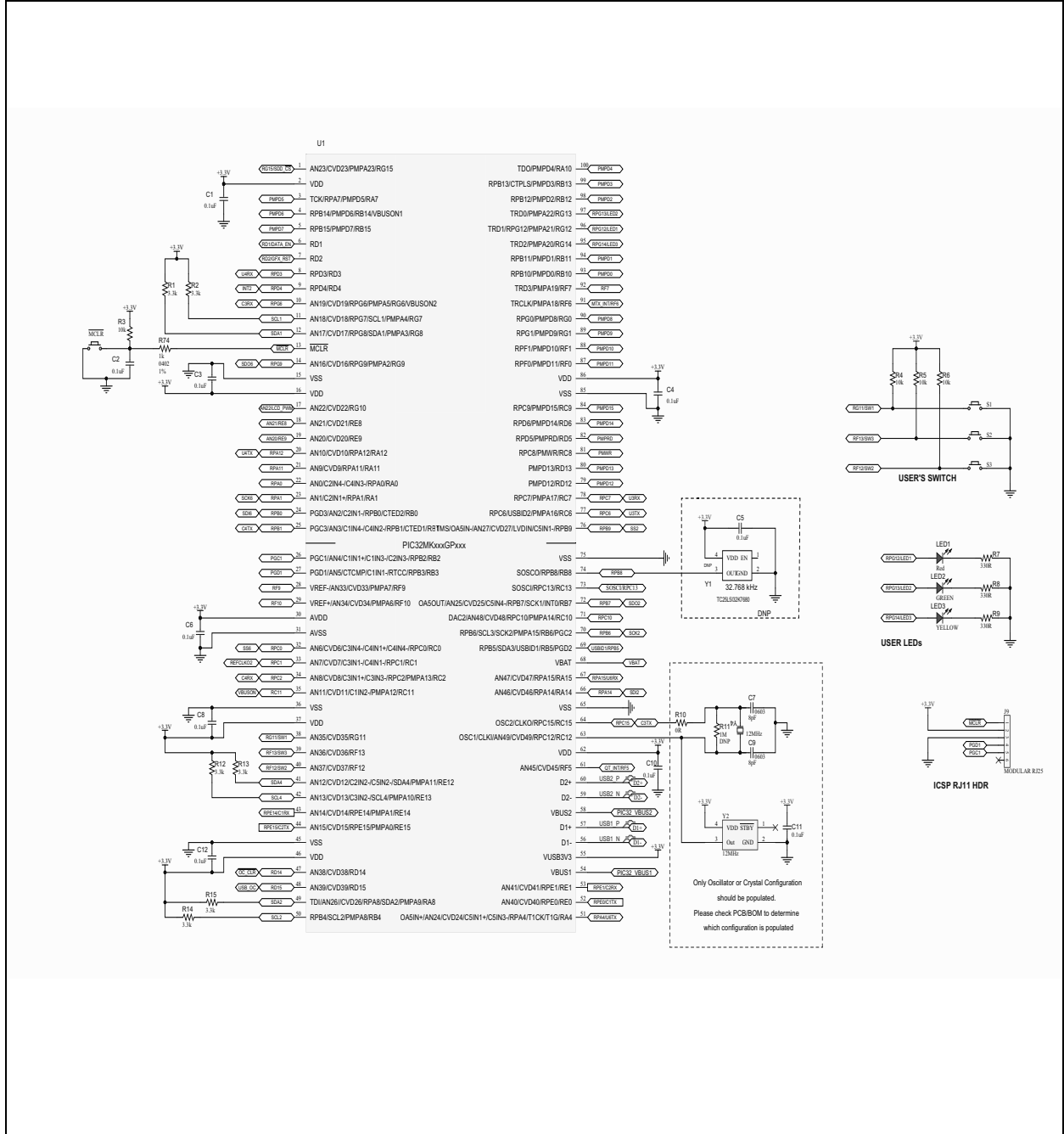

PIC32MK GP Development Board User's Guide

FIGURE A-2: PIC32MK GP DEVELOPMENT BOARD SCHEMATICS (2 OF 6)

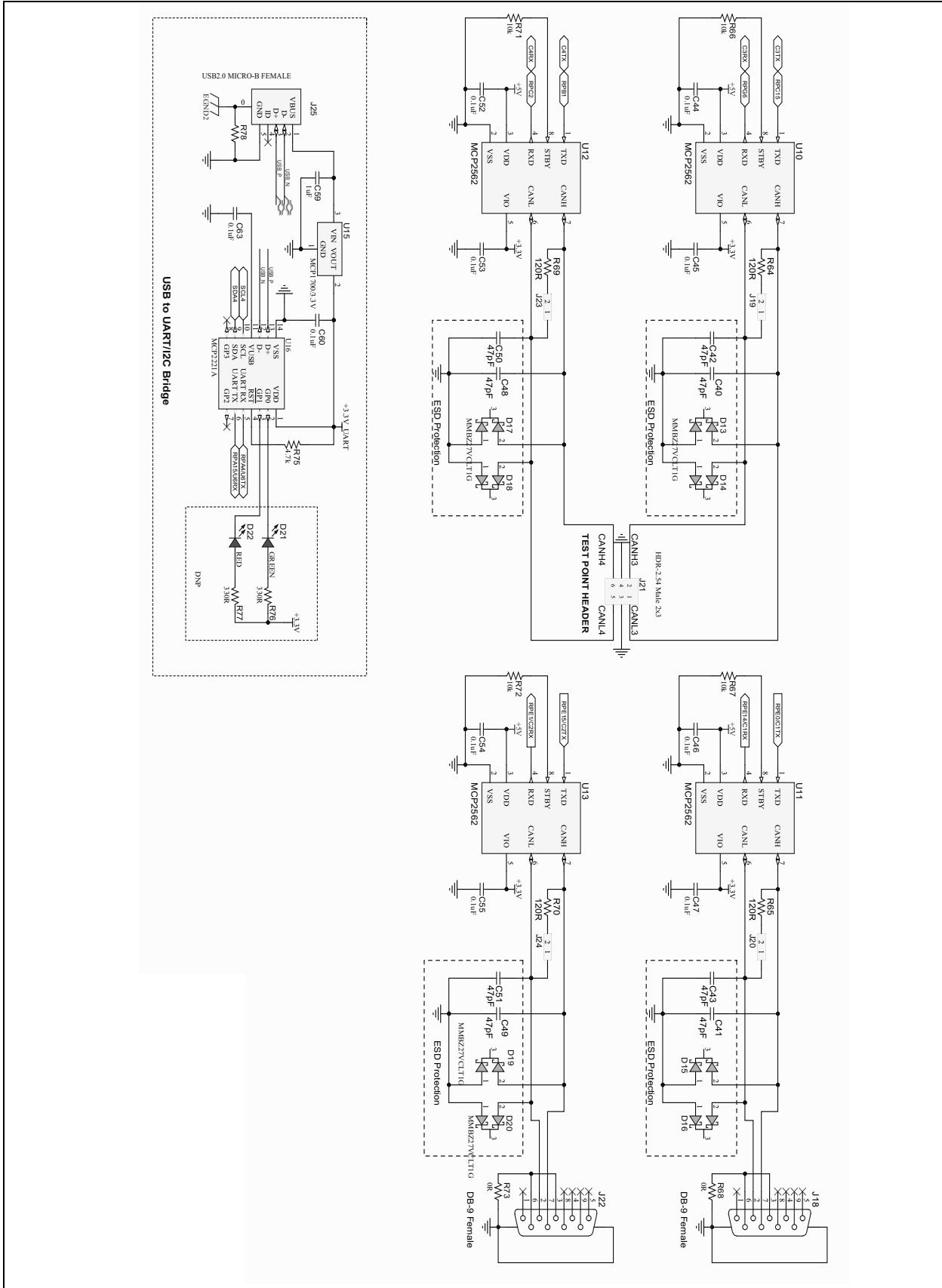
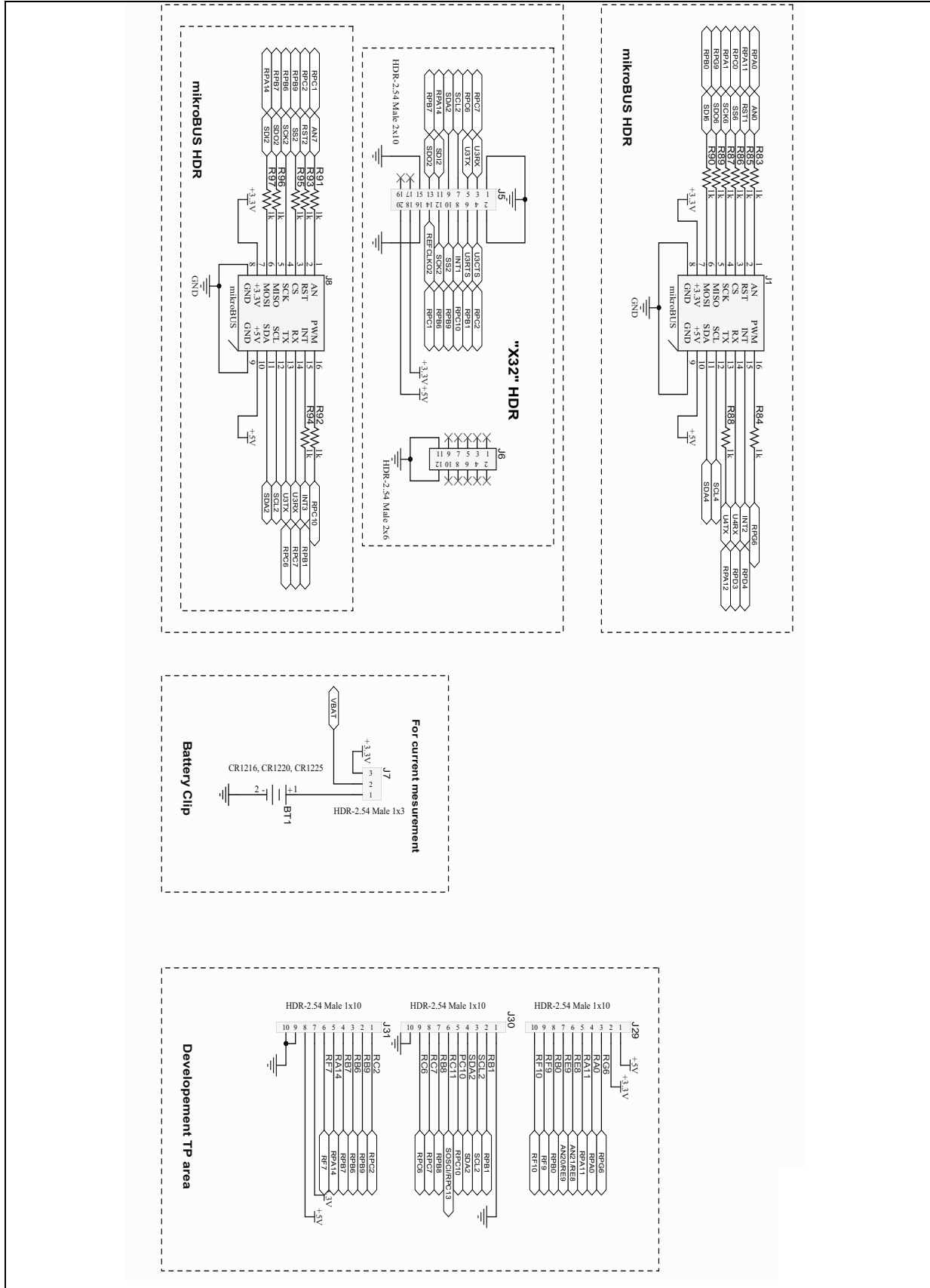

FIGURE A-3: PIC32MK GP DEVELOPMENT BOARD SCHEMATICS (3 OF 6)



PIC32MK GP Development Board User's Guide

FIGURE A-4: PIC32MK GP DEVELOPMENT BOARD SCHEMATICS (4 OF 6)

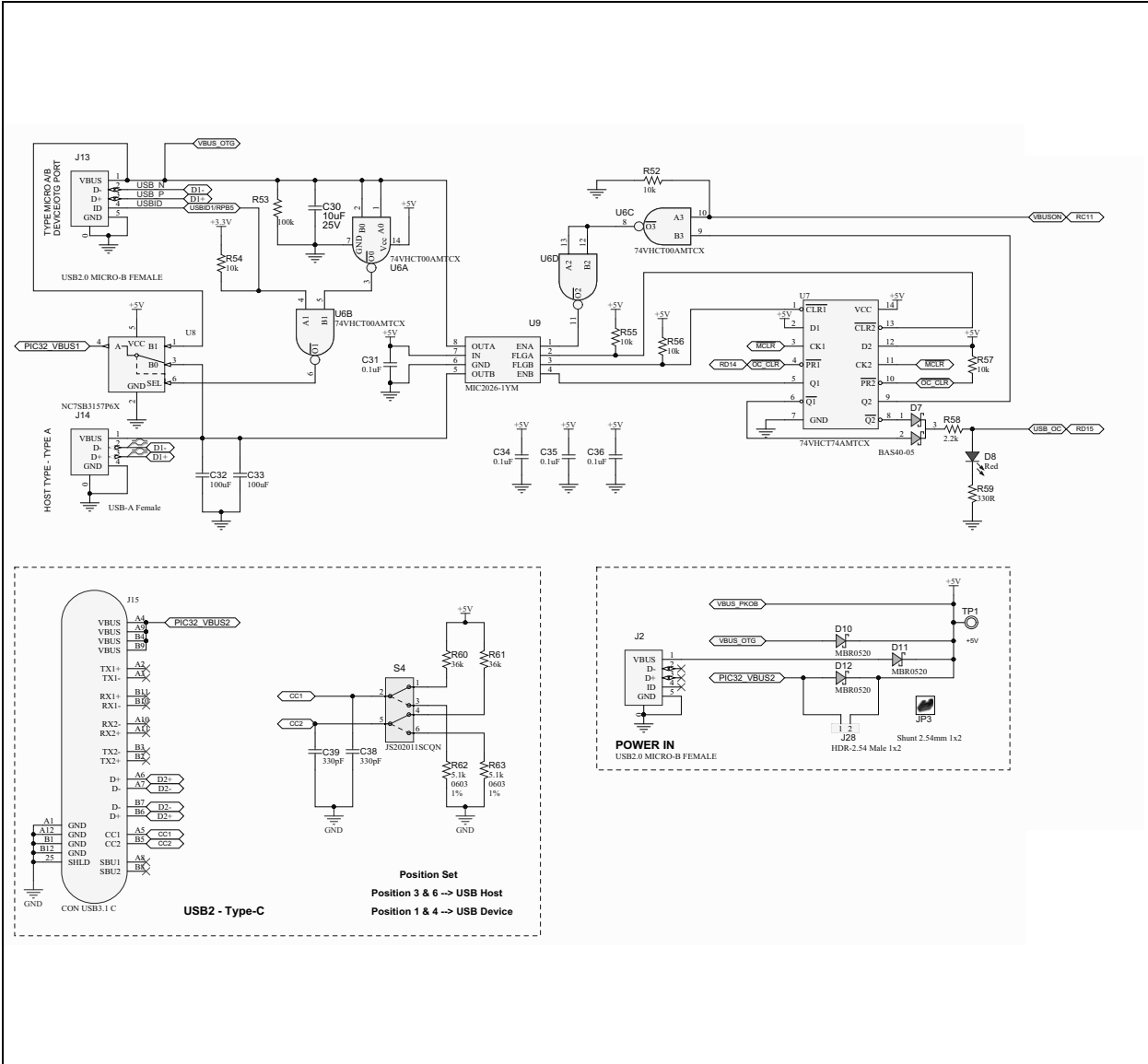
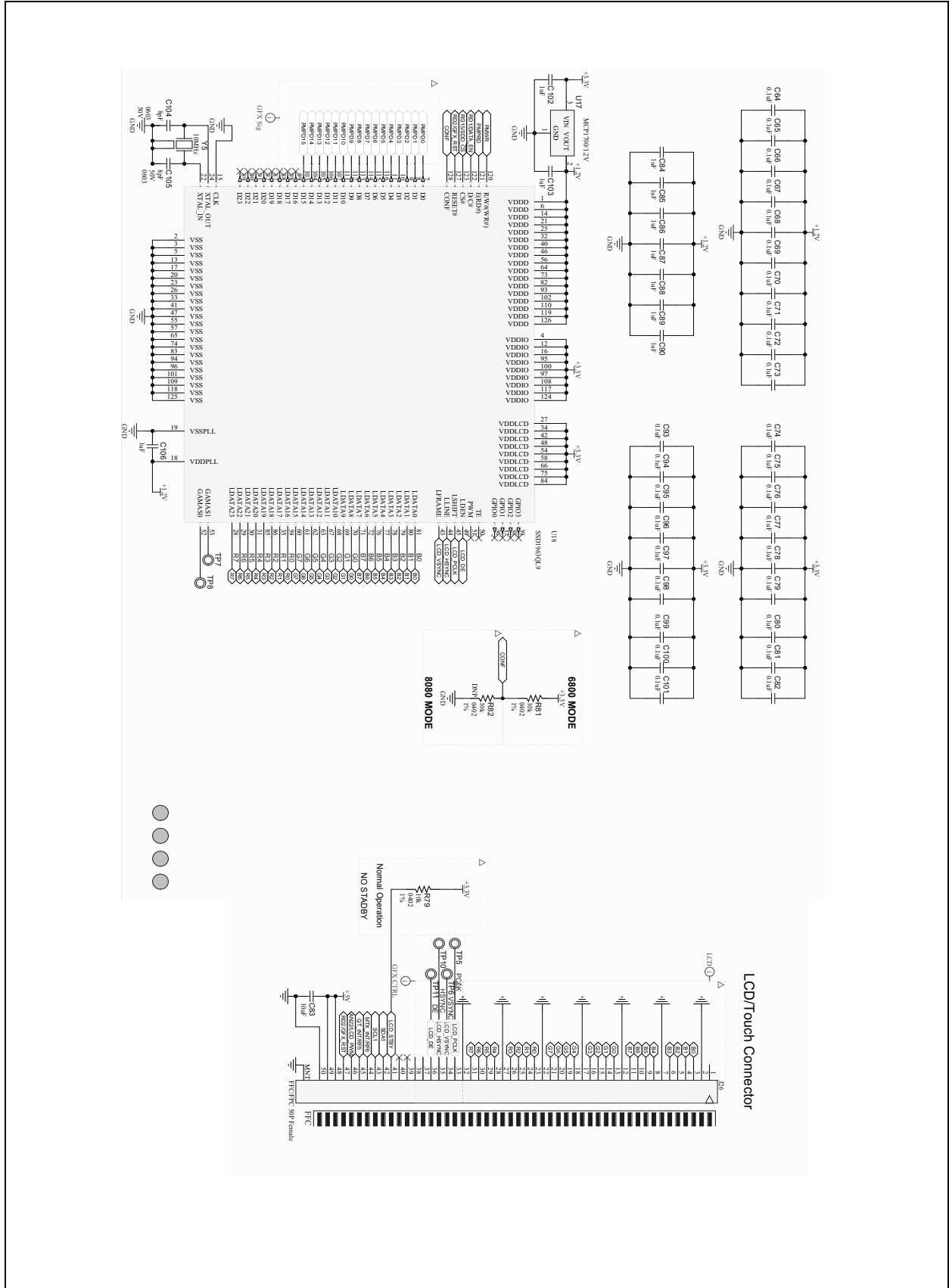
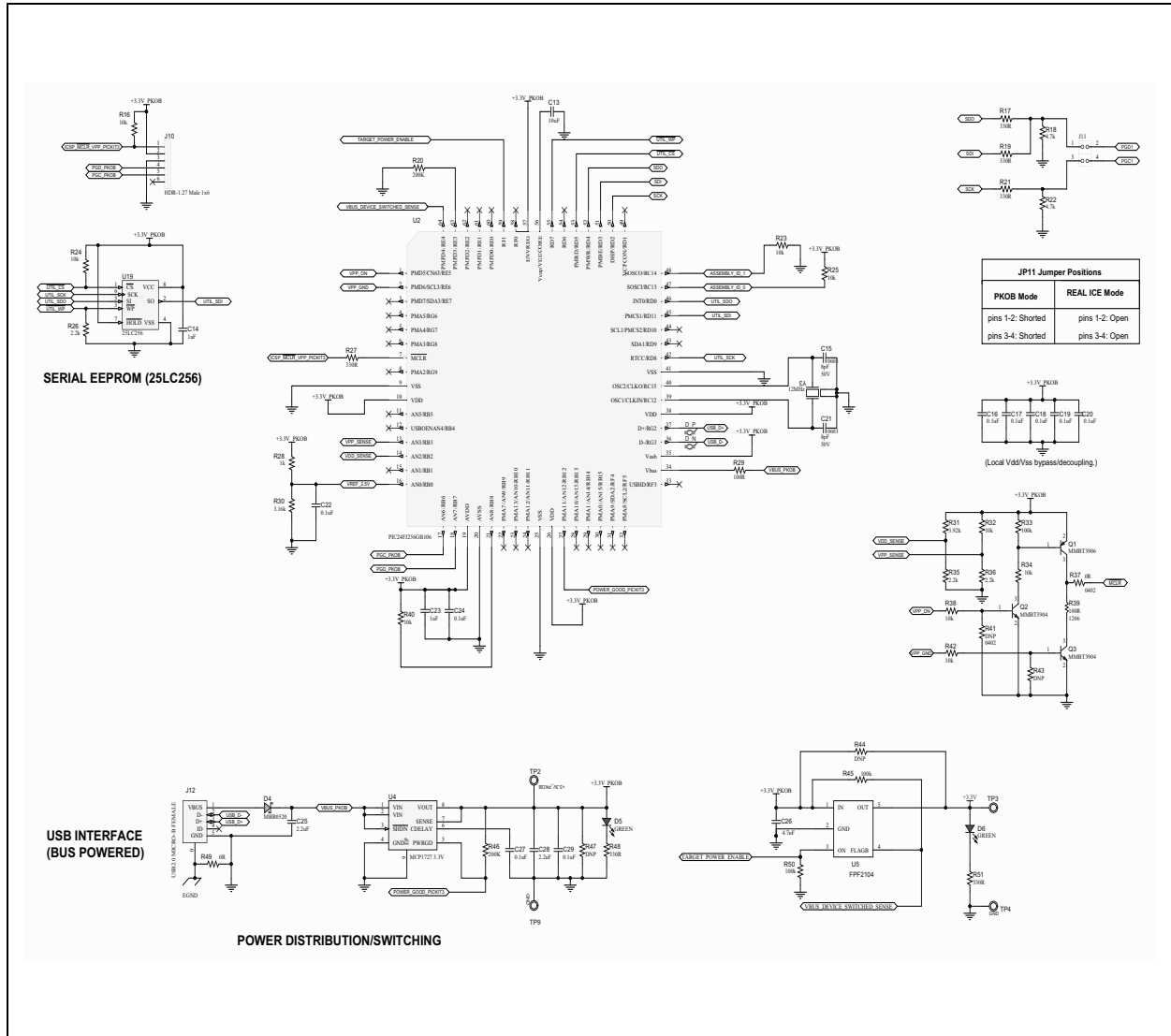

FIGURE A-5: PIC32MK GP DEVELOPMENT BOARD SCHEMATICS (5 OF 6)



PIC32MK GP Development Board User's Guide

FIGURE A-6: PIC32MK GP DEVELOPMENT BOARD SCHEMATICS (6 OF 6)





PIC32MK GP DEVELOPMENT BOARD USER'S GUIDE

Appendix B. Bill of Materials

B.1 PIC32MK GP DEVELOPMENT BOARD BILL OF MATERIALS

TABLE B-1: PIC32MK GP DEVELOPMENT BOARD BILL OF MATERIALS

QTY	DESIGNATOR	DESCRIPTION
1	BT1	BATT HOLDER Retainer SMD CR1216, CR1220, CR1225
21	C1, C2, C3, C4, C5, C6, C8, C10, C11, C12, C16, C17, C18, C19, C20, C22, C24, C27, C29, C60, C63	CAP CER 0.1uF 16V 10% X7R SMD 0402
1	C13	CAP CER 10uF 10V 10% X7R SMD 0805
13	C14, C23, C59, C84, C85, C86, C87, C88, C89, C90, C102, C103, C106	CAP CER 1uF 16V 10% X5R SMD 0402
2	C25, C28	CAP CER 2.2uF 16V 10% X5R SMD 0603
1	C26	CAP CER 4.7uF 10V 10% X5R SMD 0603
1	C30	CAP CER 10uF 25V 10% X5R SMD 0805
40	C31, C34, C35, C36, C44, C45, C46, C47, C52, C53, C54, C55, C64, C65, C66, C67, C68, C69, C70, C71, C72, C73, C74, C75, C76, C77, C78, C79, C80, C81, C82, C93, C94, C95, C96, C97, C98, C99, C100, C101	CAP CER 0.1uF 10V 10% X5R SMD 0402
2	C32, C33	CAP CER 100uF 10V 20% X5R SMD 1206
2	C38, C39	CAP CER 330pF 50V 5% NP0 SMD 0402
4	C41, C43, C49, C51	CAP CER 47pF 50V 5% NP0 SMD 0603
1	C83	CAP CER 10uF 6.3V 10% X5R SMD 0805
4	D4, D10, D11, D12	DIO SCTKY 385mV 500mA 20V SOD-123
3	D5, D6, LED2	LED GREEN 2.2V 25mA 15mcd Clear SMD 0603
1	D7	DIO SCTKYARR 1V 200mA 40V SOT-23-3
2	D8, LED1	DIO LED RED 1.75V 20mA CLEAR SMD 0603
4	D15, D16, D19, D20	DIO TVS 22V 40W SOT-23-3
2	J1, J8	mikroBUS HOST
4	J2, J12, J13, J25	CON USB2.0 MICRO-B FEMALE TH/SMD
1	J5	HDR-2.54 Male 2x10 Gold 5.84MH TH VERT
1	J6	HDR-2.54 Male 2x6 Gold 5.84MH TH VERT
1	J7	HDR-2.54 Male 1x3 Tin 5.84MH TH VERT
1	J9	CON MODULAR RJ25 TH R/A
1	J11	HDR_JMPR_2X2_TH_0.05"
1	@J11	CONN JUMPER SHORTING 1.27MM GOLD
1	J14	CON USB USB-A Female SMD R/A
1	J15	CONN RCPT USB 3.0 TYPE C R/A
2	J18, J22	CON DSUB DE-9 Female TH R/A
4	J19, J20, J23, J24	HDR-2.54 Male 1x2 Gold 5.84MH TH VERT
1	J21	HDR-2.54 Male 2x3 Gold 5.84MH TH VERT
1	J26	FFC/FPC XF2M 0.5mm 50P Female SMD R/A
1	J28	HDR-2.54 Male 1x2 Tin 5.84MH TH VERT
3	J29, J30, J31	HDR-2.54 Male 1x10 TH 5.84MH TH VERT

PIC32MK GP Development Board User's Guide

QTY	DESIGNATOR	DESCRIPTION
1	JP3	MECH HW JUMPER 2.54mm 1x2
1	LED3	DIO LED YELLOW 2.1V 20mA 6mcd Clear SMD 0603
4	MCLR, S1, S2, S3	SWITCH TACTILE SPST-NO 0.05A 12V
1	Q1	TRANS BJT PNP MMBT3906 -40V -200mA 300mW SOT-23-3
2	Q2, Q3	TRANS BJT NPN MMBT3904 40V 200mA 310mW SOT-23-3
6	R1, R2, R12, R13, R14, R15	RES TKF 3.3k 5% 1/10W SMD 0402
20	R3, R4, R5, R6, R16, R23, R24, R25, R32, R34, R38, R40, R42, R66, R67, R71, R72, R79, R81, R82	RES TKF 10k 1% 1/10W SMD 0402
10	R7, R8, R9, R17, R19, R21, R27, R48, R51, R59	RES TKF 330R 5% 1/10W SMD 0402
1	R11	RES TKF 1M 1% 1/10W SMD 0402
3	R18, R22, R75	RES TKF 4.7k 5% 1/10W SMD 0402
2	R20, R46	RES TKF 200k 1% 1/10W SMD 0402
3	R26, R35, R36	RES TKF 2.2k 1% 1/10W SMD 0402
17	R28, R74, R83, R84, R85, R86, R87, R88, R89, R90, R91, R92, R93, R94, R95, R96, R97	RES TKF 1k 1% 1/10W SMD 0402
1	R29	RES TKF 100R 5% 1/16W SMD 0402
1	R30	RES SMD 3.16K OHM 1% 1/10W 0402
1	R31	RES SMD 3.92K OHM 1% 1/10W 0402
4	R33, R45, R50, R53	RES TKF 100k 1% 1/10W SMD 0402
2	R37, R49	RES TKF 0R 1/16W SMD 0402
1	R39	RES TKF 100R 1% 1/4W SMD 1206
5	R52, R54, R55, R56, R57	RES TKF 10k 5% 1/10W SMD 0402
1	R58	RES TKF 2.2k 5% 1/16W SMD 0402
2	R60, R61	RES TKF 36k 1% 1/16W SMD 0402
2	R62, R63	RES TKF 5.1k 1% 1/10W SMD 0603
4	R64, R65, R69, R70	RES TKF 120R 1% 1/10W SMD 0603
1	R78	RES TKF 0R SMD 0402
1	S4	SWITCH SLIDE DPDT 6V 300mA SMD
2	TP4, TP9	TEST POINT MULTI PURPOSE MINI BLACK
6	TP5, TP6, TP7, TP8, TP10, TP11	CON TP TAB Silver Mini 3.8x2.03 SMD
1	U5	IC SWITCH LOAD FULL FUNC SOT23-5
1	U6	IC GATE NAND 4CH 2-INP 14-TSSOP
1	U7	IC D-TYPE POS TRG DUAL 14TSSOP
1	U8	IC SWITCH SPDT SC70-6
1	U18	1215K bytes frame buffer. Support up to 864 x 480 at 24bpp display
1	Y3	CRYSTAL 12MHz 8pF SMD NX3225SA
1	Y5	CRYSTAL 10MHz 12pF SMD ABM3B
1	U1	PIC32MK GP with CAN 1024 KB mem 100-pin
1	U2	MCHP MCU 16-BIT 32MHz 256kB 16kB PIC24FJ256GB106-I/PT TQFP-64
1	U4	MCHP ANALOG LDO 3.3V MCP1727-3302E/FM
1	U9	IC SWITCHER MIC2026-1YM Dual-Channel Power Distribution Switch SOIC-8
4	U10, U11, U12, U13	MCHP INTERFACE CAN SOIC-8
1	U15	MCHP ANALOG LDO 3.3V SOT-23-3
1	U16	MCHP INTERFACE USB I2C UART TSSOP-14
1	U17	CHP ANALOG LDO 1.2V SOT-23-3
1	U19	MCHP MEMORY SERIAL EEPROM 256k SPI SOIC-8

Bill of Materials

QTY	DESIGNATOR	DESCRIPTION
1	Y2	CRYSTAL OSC_DSC1001_12MHz_1.8V~3.3V
DNP	R11, R59, R61, R87, R70, R84, R71	
DNP	R22, R23, R24, R25, R26, R27	
DNP	D11	DIODE GEN PURP 75V 150MA 0402
DNP	J11	Terminal Strip, Dual Row Horizontal, Surface Mount, 0.100" Pitch
DNP	J15	CON HDR-2.54 Male 2x20 Gold 5.84MH TH VERT
DNP	J12, J18	CON HDR-1.27 Female 1x6 Gold TH VERT

Legend: DNP = Do Not Place

NOTES:

NOTES:

Worldwide Sales and Service

AMERICAS

Corporate Office
2355 West Chandler Blvd.
Chandler, AZ 85224-6199

Tel: 480-792-7200
Fax: 480-792-7277

Technical Support:
<http://www.microchip.com/support>

Web Address:
www.microchip.com

Atlanta
Duluth, GA
Tel: 678-957-9614
Fax: 678-957-1455

Austin, TX
Tel: 512-257-3370

Boston
Westborough, MA
Tel: 774-760-0087
Fax: 774-760-0088

Chicago
Itasca, IL
Tel: 630-285-0071
Fax: 630-285-0075

Dallas
Addison, TX
Tel: 972-818-7423
Fax: 972-818-2924

Detroit
Novi, MI
Tel: 248-848-4000

Houston, TX
Tel: 281-894-5983

Indianapolis
Noblesville, IN
Tel: 317-773-8323
Fax: 317-773-5453
Tel: 317-536-2380

Los Angeles
Mission Viejo, CA
Tel: 949-462-9523
Fax: 949-462-9608
Tel: 951-273-7800

Raleigh, NC
Tel: 919-844-7510

New York, NY
Tel: 631-435-6000

San Jose, CA
Tel: 408-735-9110
Tel: 408-436-4270

Canada - Toronto
Tel: 905-695-1980
Fax: 905-695-2078

ASIA/PACIFIC

Asia Pacific Office
Suites 3707-14, 37th Floor
Tower 6, The Gateway
Harbour City, Kowloon

Hong Kong
Tel: 852-2943-5100
Fax: 852-2401-3431

Australia - Sydney
Tel: 61-2-9868-6733
Fax: 61-2-9868-6755

China - Beijing
Tel: 86-10-8569-7000
Fax: 86-10-8528-2104

China - Chengdu
Tel: 86-28-8665-5511
Fax: 86-28-8665-7889

China - Chongqing
Tel: 86-23-8980-9588
Fax: 86-23-8980-9500

China - Dongguan
Tel: 86-769-8702-9880

China - Guangzhou
Tel: 86-20-8755-8029

China - Hangzhou
Tel: 86-571-8792-8115
Fax: 86-571-8792-8116

China - Hong Kong SAR
Tel: 852-2943-5100
Fax: 852-2401-3431

China - Nanjing
Tel: 86-25-8473-2460
Fax: 86-25-8473-2470

China - Qingdao
Tel: 86-532-8502-7355
Fax: 86-532-8502-7205

China - Shanghai
Tel: 86-21-3326-8000
Fax: 86-21-3326-8021

China - Shenyang
Tel: 86-24-2334-2829
Fax: 86-24-2334-2393

China - Shenzhen
Tel: 86-755-8864-2200
Fax: 86-755-8203-1760

China - Wuhan
Tel: 86-27-5980-5300
Fax: 86-27-5980-5118

China - Xian
Tel: 86-29-8833-7252
Fax: 86-29-8833-7256

ASIA/PACIFIC

China - Xiamen
Tel: 86-592-2388138
Fax: 86-592-2388130

China - Zhuhai
Tel: 86-756-3210040
Fax: 86-756-3210049

India - Bangalore
Tel: 91-80-3090-4444
Fax: 91-80-3090-4123

India - New Delhi
Tel: 91-11-4160-8631
Fax: 91-11-4160-8632

India - Pune
Tel: 91-20-3019-1500

Japan - Osaka
Tel: 81-6-6152-7160
Fax: 81-6-6152-9310

Japan - Tokyo
Tel: 81-3-6880-3770
Fax: 81-3-6880-3771

Korea - Daegu
Tel: 82-53-744-4301
Fax: 82-53-744-4302

Korea - Seoul
Tel: 82-2-554-7200
Fax: 82-2-558-5932 or
82-2-558-5934

Malaysia - Kuala Lumpur
Tel: 60-3-6201-9857
Fax: 60-3-6201-9859

Malaysia - Penang
Tel: 60-4-227-8870
Fax: 60-4-227-4068

Philippines - Manila
Tel: 63-2-634-9065
Fax: 63-2-634-9069

Singapore
Tel: 65-6334-8870
Fax: 65-6334-8850

Taiwan - Hsin Chu
Tel: 886-3-5778-366
Fax: 886-3-5770-955

Taiwan - Kaohsiung
Tel: 886-7-213-7830

Taiwan - Taipei
Tel: 886-2-2508-8600
Fax: 886-2-2508-0102

Thailand - Bangkok
Tel: 66-2-694-1351
Fax: 66-2-694-1350

EUROPE

Austria - Wels
Tel: 43-7242-2244-39
Fax: 43-7242-2244-393

Denmark - Copenhagen
Tel: 45-4450-2828
Fax: 45-4485-2829

Finland - Espoo
Tel: 358-9-4520-820

France - Paris
Tel: 33-1-69-53-63-20
Fax: 33-1-69-30-90-79

France - Saint Cloud
Tel: 33-1-30-60-70-00

Germany - Garching
Tel: 49-8931-9700

Germany - Haan
Tel: 49-2129-3766400

Germany - Heilbronn
Tel: 49-7131-67-3636

Germany - Karlsruhe
Tel: 49-721-625370

Germany - Munich
Tel: 49-89-627-144-0
Fax: 49-89-627-144-44

Germany - Rosenheim
Tel: 49-8031-354-560

Israel - Ra'anana
Tel: 972-9-744-7705

Italy - Milan
Tel: 39-0331-742611
Fax: 39-0331-466781

Italy - Padova
Tel: 39-049-7625286

Netherlands - Druen
Tel: 31-416-690399
Fax: 31-416-690340

Norway - Trondheim
Tel: 47-7289-7561

Poland - Warsaw
Tel: 48-22-3325737

Romania - Bucharest
Tel: 40-21-407-87-50

Spain - Madrid
Tel: 34-91-708-08-90
Fax: 34-91-708-08-91

Sweden - Gothenberg
Tel: 46-31-704-60-40

Sweden - Stockholm
Tel: 46-8-5090-4654

UK - Wokingham
Tel: 44-118-921-5800
Fax: 44-118-921-5820