

Specification: (Ta=32°C)	Code:	Description:
Heat transfer, cold side:	D	Direct
Heat transfer, warm side:	A	Air
Cascade:	-	
Cooling power: [W]	75	71 W at dT=0°C. Tolerance: ±10%.
Voltage, nominal: [VDC]	24	24 VDC
TEM Voltage: [VDC]		Nominal: 24 VDC, Max: 30 VDC
TEM Current: [A]		Nominal: 3.7 A, Initial: 4.5 A. All at dT=0°C. Tolerance: ±10%.
Fan(s), cold side:	0	None.
Fan(s), warm side:	2	L10: 50,000 hrs. at 25°C. Nominal current: 0.21 A. Voltage: 24 VDC ±10%.
Temperature controller, sensor:	0	None.
Temperature control settings, trim options:	0	-
Additional controller information:		
Temperature control position:	0	-
Options:	0	-
Overheating thermostat:		75°C ±5°C on hot side heat sink surface.
Operating temperature:		-10°C to +49°C at nominal voltage.
TE-Module(s) temperature specification:		Max. surface temperature: 80°C.
Enclosed:		-
Packing:		Individual cardboard box.

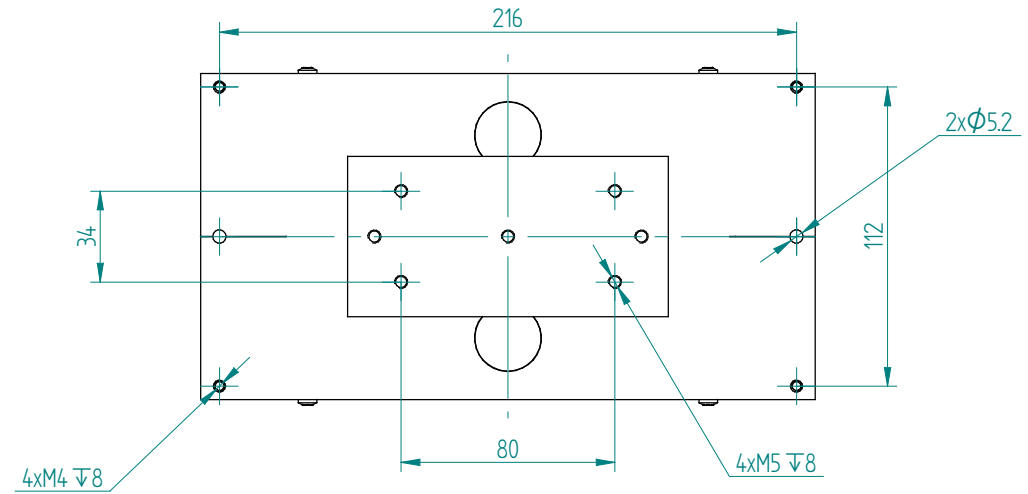

General tolerances: SS-ISO 2768-1 v  
 First angle projection: Dimension units: Metric: [mm]

Comment / Deviations:

Hi-Pot tested 750VDC

Designed by: A. Kim	Checked by: C. Johansson	Approved by: C. Johansson	Release date: 2011-06-22	Project: Standard	Customer:
Laird Technologies S-43153 Molndal, Sweden tfn: +46 31 420530, fax: +46 31 247909 e-mail: info@lairdtech.com Web: www.lairdtech.com			Title: <b>TE ASSEMBLY 24VDC DIRECT - AIR</b>		
Part nr: DA-075-24-02-00-00			Rev. 04	Version:	Scale: Size, sheet 1:2 A3, 1/4

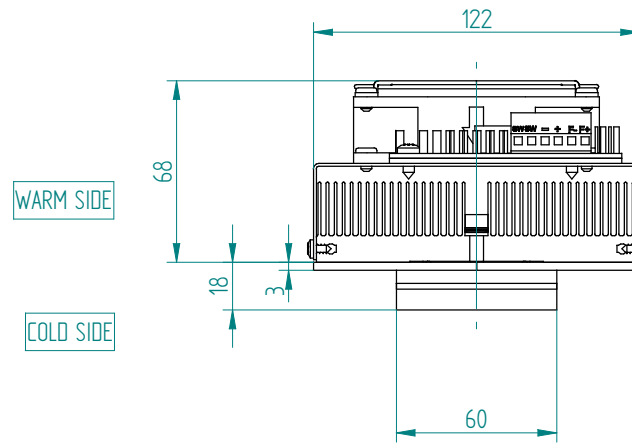
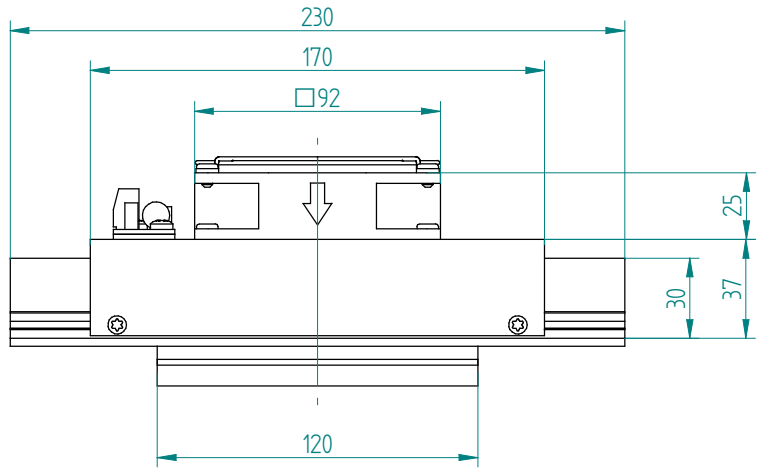

D-Plate tolerances:

Flatness:  $\square 0.1/100$

Roughness:  $\surd 3.2$

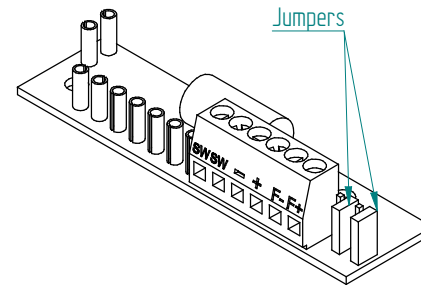
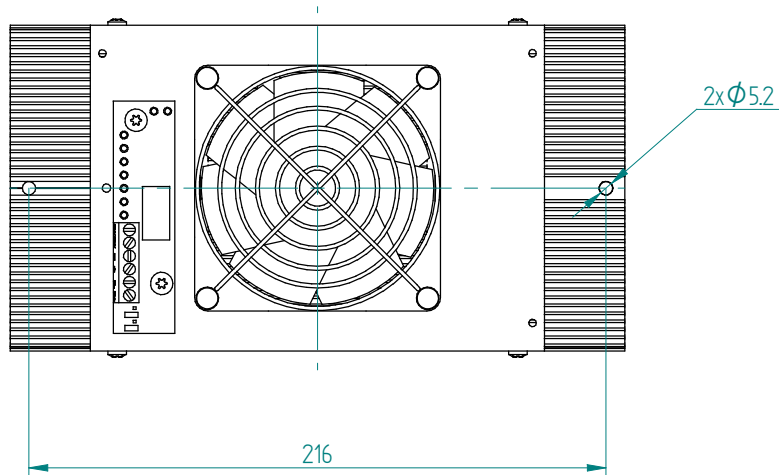

Electrical connections:

- "+" : + TEM
- "-" : - TEM
- "F+" : + Fan(s)
- "F-" : - Fan(s)

To use single supply:  
Lift the jumpers and rotate 90° to short-cut the pin pairs.  
Connect the unit to "+" & "-".

Warning: Single supply not applicable in heating mode or with PWM-regulation.

General tolerances: SS-ISO 2768-1 v	First angle projection:	Dimension units: Metric: [mm]
--	-------------------------	----------------------------------

Comment / Deviations: Hi-Pot tested 750VDC					
Designed by: A. Kim	Checked by: C. Johansson	Approved by: C. Johansson	Release date: 2011-06-22	Project: Standard	Customer:
Laird Technologies S-43153 Molndal, Sweden tfn: +46 31 420530, fax: +46 31 247909 e-mail: info@lairdtech.com Web: www.lairdtech.com			Title: TE ASSEMBLY 24VDC DIRECT - AIR		
			Part nr: DA-075-24-02-00-00	Rev. 04	Version: