

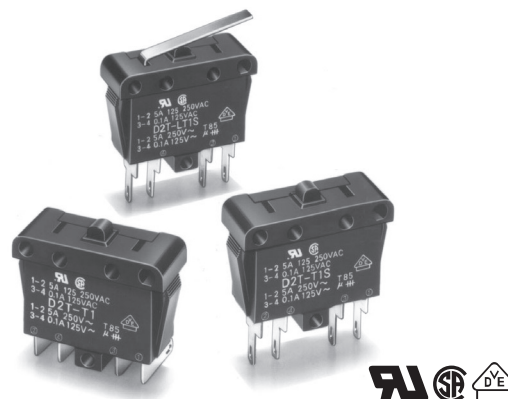

Door Interlock Switch D2T

Compact DPST-NO Snap Action Switch

- Incorporates circuits for power and low-level loads
- Approved by safety standards, such as UL, CSA, and VDE
- As compact as OMRON's V-series snap action switches
- Contact gap of 0.7 mm min.
- Panel or screw-mounted with ease
- Straight and angled terminals are available
- RoHS Compliant



Ordering Information

Actuator	Right-angled solder terminal	Straight solder terminal
Pin plunger 	D2T-T1	D2T-T1S
Hinge lever 	D2T-LT1	D2T-LT1S

Note: The actuator of the D2T is identical to that used for OMRON's V-series Snap-action Switches. The actuator can be replaced with other types of actuators. Contact your OMRON representative for details.

Model Number Legend

D2T-□T1□
1 2

- Actuator**
None: Pin plunger
L: Hinge lever

- Terminals**
None: Right-angled solder terminals
S: Straight solder terminals

Specifications

■ Characteristics (Initial)

Operating speed	10 to 500 mm/second
Operating frequency	Mechanical: 120 operations per minute max. Electrical: 30 operations per minute max.
Contact resistance	50 mΩ max. between terminals 1 and 2 100 mΩ max. between terminals 3 and 4
Insulation resistance	100 MΩ min. (at 500 VDC)
Dielectric strength (See note 1)	1,000 VAC for 1 minute 50/60 Hz between terminals of same polarity 1,500 VAC for 1 minute 50/60 Hz between current-carrying metal parts and ground, and between each terminal and non-current-carrying metal part, and between terminals of different polarity
Vibration resistance (See note 2)	Malfunction: 10 to 55 Hz, 1.5 mm double amplitude
Shock resistance (See note 2)	Destruction: 1,000 m/s ² (approx 100G) max. Malfunction: 300 m/s ² (approx. 30G) max.
Degree of protection	IEC IP40
Degree of protection vs. electric shock	Class I
Proof tracking index (PTI)	175
Ambient operating temperature	-25° to 85°C (at 60% RH max.) with no icing
Ambient operating humidity	85% max (for 5°C to 35°C)
Life expectancy	Mechanical: 100,000 operations min. at 60 operations/minute Electrical: 100,000 operations min. at 30 operations/minute
Weight	Approx. 10 g (for pin plunger models)

Note: 1. The dielectric strength shown is measured using a separator between the switch and metal mounting plate
2. For the pin plunger models, the above values apply for use at the free position and total travel position.
For lever models, they apply at the total travel position. Contact opening or closing time is within 1 ms.

■ Ratings (Reference values)

Voltage	Resistive Load	
	Between terminals 1 and 2	Between terminals 3 and 4
250 VAC	5A	---
125 VAC	5A	0.1A
30 VDC	6A	0.1A

Note: The ratings apply under the following test conditions: Ambient Temperature = 20±2°C, Ambient Humidity = 65±5%, Operating frequency = 30 operations/min.

■ Approved Standards

UL Recognized
CSA Certified

Rated voltage	Between terminals 1 and 2	Between terminals 3 and 4
125 VAC	5A	0.1A (for 100,000 operations)
250 VAC	5A	---

EN61058-1 (VDE approval)

Rated voltage	Between terminals 1 and 2	Between terminals 3 and 4
125 VAC	---	0.1A
250 VAC	5A	---

Testing conditions: 5E4 (50,000 operations), T85 (0°C to 85°C)

■ Contact Specifications

Item	Terminals 1 and 2	Terminals 3 and 4
Specification	Rivet	Plated
Material	Silver	
Gap (standard value)	1 mm	1.4 mm
Inrush current	60 A max.	---
Minimum applicable load (see note)	160 mA at 5 VDC	1 mA at 5 VDC

Note: Minimum applicable loads are indicated by N standard reference values. This value represents the failure rate at a 60% (λ_{60}) reliability level (JIS C5003). The equation $\lambda_{60}=0.5 \times 10^{-6}$ / operations indicates that a failure rate of 1/2,000,000 operations can be expected at a reliability level of 60%

Engineering Data

■ Contact Form

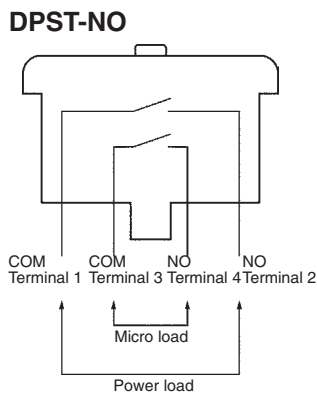

Note: The circuit switching power load has a snap-action mechanism. The circuit switching low-level load has a slow-action mechanism.

■ Mounting Holes

All switches may be panel mounted using M3 mounting screws with plane washers or spring washers to securely mount the switch. Tighten the screws to a torque of 0.4 to 0.6 N·m

Panel Mount Holes

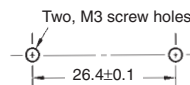

Panel Cutout Dimensions

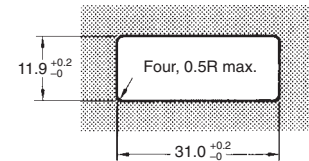

(Panel thickness: 1.5 to 2 mm)

When mounting on a metal surface, be sure to provide a separator between the switch and mounting plate.

Dimensions

■ Terminals

Note: Unless otherwise specified, all units are in millimeters

Angled Terminals

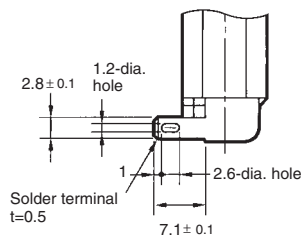

Straight Terminals

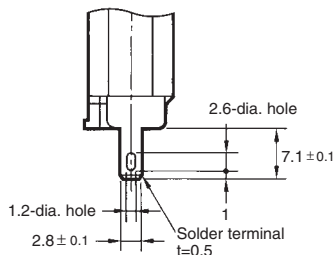

■ Dimensions and Operating Characteristics

- Note:**
1. Unless otherwise specified, all units are in millimeters and a tolerance of ± 0.4 mm applies to all dimensions
 2. The following illustrations and dimensions are for D2T models with angled terminals. Refer to the dimensions in "Terminals" for the straight terminal versions of D2T.
 3. The operating characteristics are for operation in the A direction (↓)

Pin Plunger Models

D2T-T1
D2T-T1S

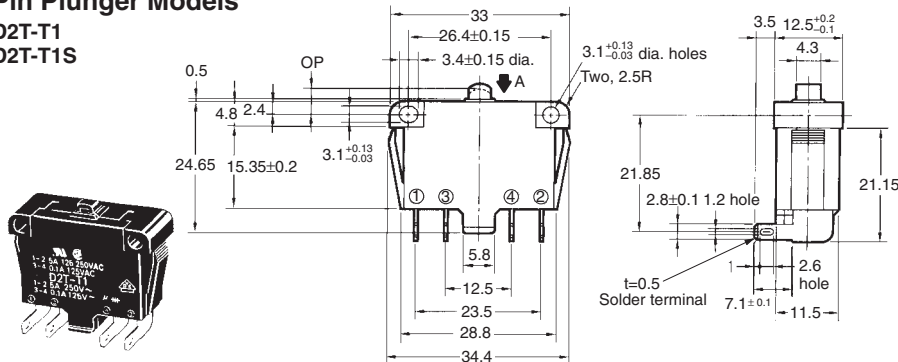

OF max.	330 gf
RF min.	50 gf
TTF max.	650 gf
OT min.	0.8 mm
OP	4.4 ± 0.6 mm (see note)

Note: Operating sequence of the circuit between terminals 1 and 2 and the circuit between terminals 3 and 4 is not specified.

Hinge Lever Models

D2T-LT1
D2T-LT1S

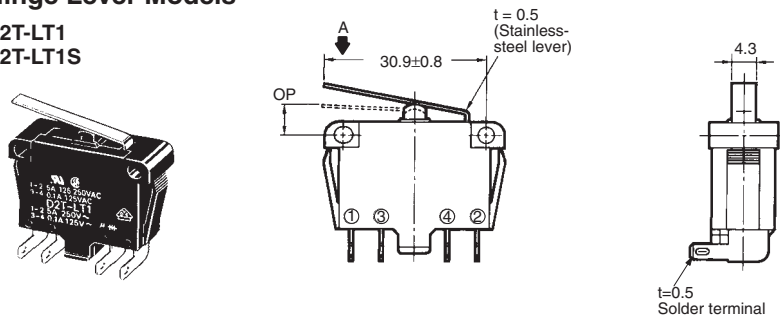

OF max.	150 gf
RF min.	20 gf
TTF max.	250 gf
OT min.	1.6 mm
OP	6.9 ± 1.3 mm (see note)

Note: Operating sequence of the circuit between terminals 1 and 2 and the circuit between terminals 3 and 4 is not specified.

Precautions

Be sure to read the precautions and information common to all Snap Action and Detection Switches, contained in the Technical User's Guide, "Snap Action Switches, Technical Information" for correct use.

All sales are subject to Omron Electronic Components LLC standard terms and conditions of sale, which can be found at http://www.components.omron.com/components/web/webfiles.nsf/sales_terms.html

ALL DIMENSIONS SHOWN ARE IN MILLIMETERS.
To convert millimeters into inches, multiply by 0.03937. To convert grams into ounces, multiply by 0.03527.

OMRON[®]

**OMRON ELECTRONIC
COMPONENTS LLC**

55 E. Commerce Drive, Suite B
Schaumburg, IL 60173

847-882-2288

OMRON ON-LINE

Global - <http://www.omron.com>

USA - <http://www.components.omron.com>