

D2E146-HT65-64

# AC centrifugal fan

forward-curved, dual-intake

with housing (flange)

## ebm-papst Mulfingen GmbH & Co. KG

Bachmühle 2 · D-74673 Mulfingen

Phone +49 7938 81-0

Fax +49 7938 81-110

info1@de.ebmpapst.com

www.ebmpapst.com

Limited partnership · Headquarters Mulfingen

Amtsgericht (court of registration) Stuttgart · HRA 590344

General partner Elektrobau Mulfingen GmbH · Headquarters Mulfingen

Amtsgericht (court of registration) Stuttgart · HRB 590142

## Nominal data

Type	D2E146-HT65-64	
Motor	M2E068-EC	
Phase		1~
Nominal voltage	VAC	115
Frequency	Hz	60
Method of obtaining data		ml
Valid for approval/standard		CE
Speed (rpm)	min <sup>-1</sup>	2000
Power consumption	W	430
Current draw	A	3.75
Capacitor	µF	25
Capacitor voltage	VDB	240
Capacitor standard		S2 (CE)
Min. back pressure	Pa	100
Min. back pressure	inH <sub>2</sub> O	0.4
Min. ambient temperature	°C	-25
Max. ambient temperature	°C	40

ml = Max. load · me = Max. efficiency · fa = Free air · cs = Customer specification · ce = Customer equipment  
Subject to change



# AC centrifugal fan

forward-curved, dual-intake

with housing (flange)

## Technical description

<b>Weight</b>	3.7 kg
<b>Fan size</b>	146 mm
<b>Rotor surface</b>	Unpainted
<b>Terminal box material</b>	PP plastic
<b>Impeller material</b>	Sheet steel, galvanized
<b>Housing material</b>	PP plastic
<b>Motor suspension</b>	Motor vibration-damped on both sides
<b>Direction of rotation</b>	Counterclockwise, viewed toward rotor
<b>Degree of protection</b>	IP20
<b>Insulation class</b>	"F"
<b>Moisture (F) / Environmental (H) protection class</b>	H0 - dry environment
<b>Max. permitted ambient temp. for motor (transport/storage)</b>	+ 80 °C
<b>Min. permitted ambient temp. for motor (transport/storage)</b>	- 40 °C
<b>Installation position</b>	Shaft horizontal or rotor on bottom; rotor on top on request
<b>Condensation drainage holes</b>	None, open rotor
<b>Mode</b>	S1
<b>Motor bearing</b>	Ball bearing
<b>Speed levels</b>	4
<b>Touch current according to IEC 60990 (measuring circuit Fig. 4, TN system)</b>	< 0.75 mA
<b>Electrical hookup</b>	With plug; Via terminal box, capacitor integrated and connected
<b>Motor protection</b>	Thermal overload protector (TOP) internally connected
<b>With cable</b>	Variable
<b>Protection class</b>	I (with customer connection of protective earth)
<b>Motor capacitor according to EN 60252-1 in safety protection class</b>	S2
<b>Conformity with standards</b>	EN 60335-1; CE
<b>Approval</b>	CSA C22.2 No. 100; UL 1004-1



# AC centrifugal fan

forward-curved, dual-intake  
with housing (flange)

## Product drawing

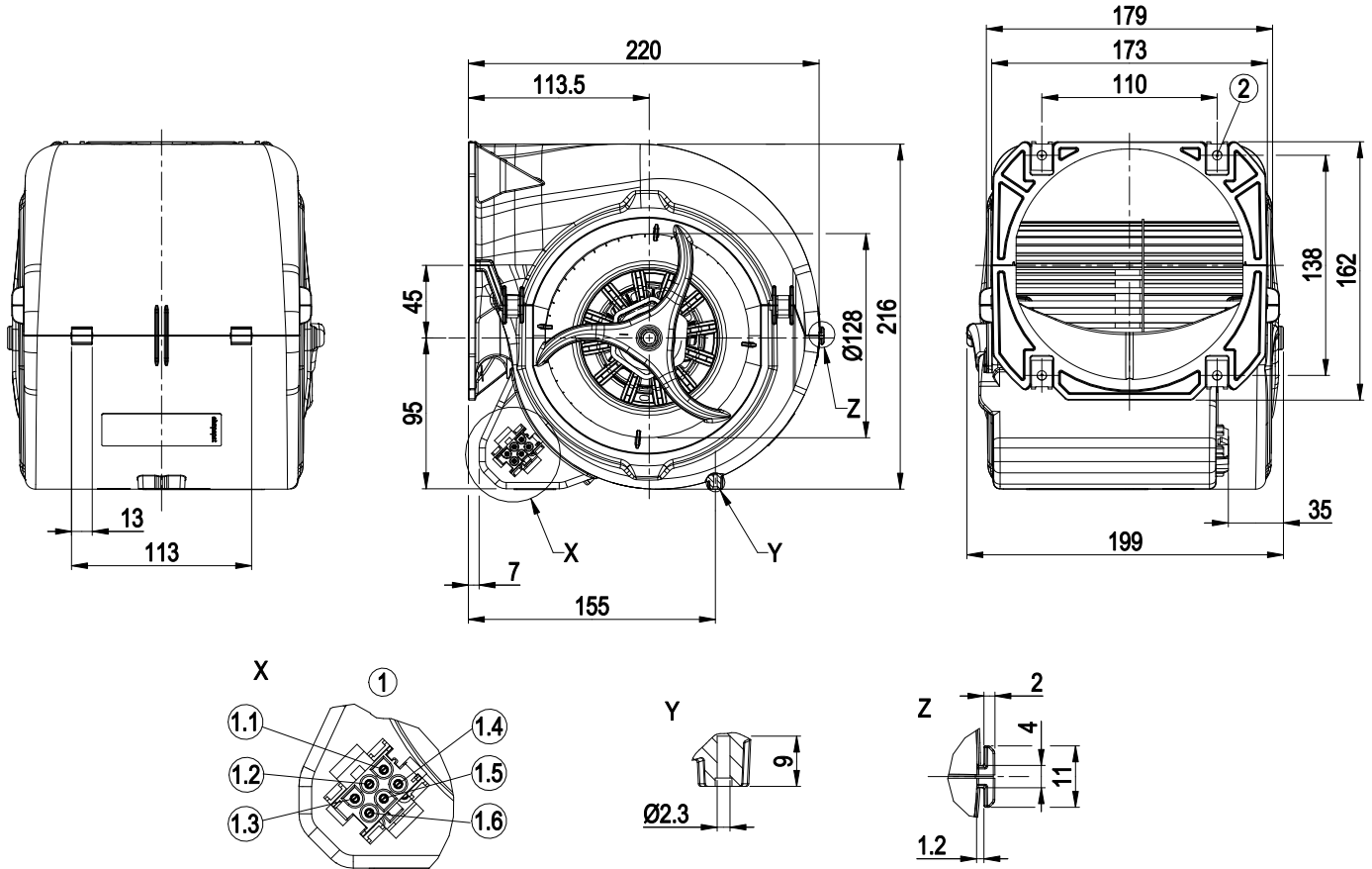

1	Coded plug system AMP Universal Mate-N-Lok; connector housing: AMP 926 682-3; 6x plug pin AMP 926 886-1
1.1	L = step 1 (min.)
1.2	L = step 2
1.3	L = step 3
1.4	L = step 4 (max.)
1.5	N
1.6	PE (green/yellow)
2	4x sheet metal nut for thread EN ISO 1478-ST4.8 (min. screw length 14.5 mm plus material thickness of mounting)



# AC centrifugal fan

forward-curved, dual-intake  
with housing (flange)

## Connection diagram

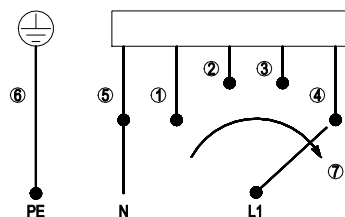

The switch must interrupt the circuit when switching.

1	Step 1 (min.)	2	Step 2	3	Step 3
4	Step 4 (max.)	5	N	6	PE protective earth
7	Speed increasing				

# AC centrifugal fan

forward-curved, dual-intake

with housing (flange)

## Curves: Air performance 60 Hz

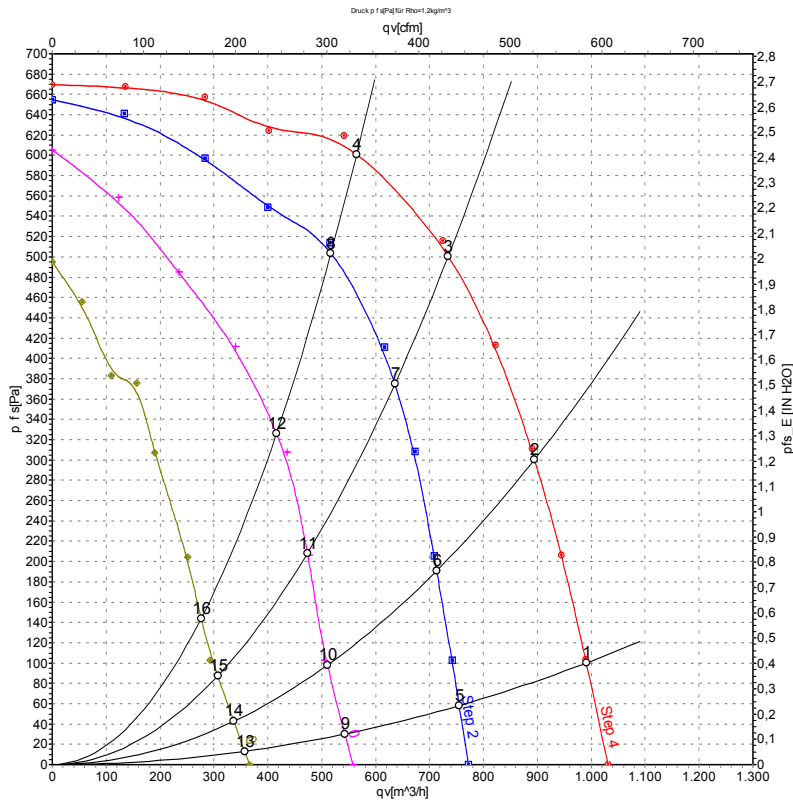

Measurement: LU-45289-1  
 Measurement: LU-45290-1  
 Measurement: LU-45291-1  
 Measurement: LU-45292-1

Air performance measured according to ISO 5801 installation category A. For detailed information on the measurement setup, contact ebm-papst. Intake sound level: Sound power level according to ISO 13347 / sound pressure level measured at 1 m distance from fan axis. The values given are valid under the specified measuring conditions and may vary due to conditions of installation. For deviations from the standard configuration, the parameters have to be checked on the installed unit.

## Measured values

	Stage	U	f	n	Pe	I	qv	Pfs	qv	Pfs
		V	Hz	min <sup>-1</sup>	W	A	m <sup>3</sup> /h	Pa	cfm	inH2O
1	4	115	60	2000	430	3.75	990	100	585	0.40
2	4	115	60	2340	419	3.63	895	300	525	1.20
3	4	115	60	2685	382	3.31	735	500	430	2.01
4	4	115	60	2925	345	2.99	565	600	335	2.41
5	3	115	60	1560	325	2.87	755	59	445	0.24
6	3	115	60	1890	313	2.79	715	191	420	0.77
7	3	115	60	2325	288	2.63	635	376	375	1.51
8	3	115	60	2710	256	2.42	515	512	305	2.06
9	2	115	60	1135	252	2.27	540	29	320	0.12
10	2	115	60	1350	244	2.22	510	91	300	0.37
11	2	115	60	1755	234	2.16	475	211	280	0.85
12	2	115	60	2175	217	2.06	415	329	245	1.32
13	1	115	60	750	194	1.78	355	13	210	0.05
14	1	115	60	900	192	1.77	335	42	200	0.17
15	1	115	60	1115	188	1.74	305	82	180	0.33
16	1	115	60	1415	183	1.71	275	143	160	0.57

U = Power supply · f = Frequency · n = Speed (rpm) · Pe = Power consumption · I = Current draw · qv = Air flow · Pfs = Pressure increase

