

SPECIFICATIONS

Electrical Ratings	50mA @ 50VDC
Electrical Life	100,000 cycles typical
Contact Resistance	< 50 mΩ initial
Actuation Force	100, 130, 160, 260 +/- 50gF
Actuator Travel	.25 +/- .1mm
Dielectric Strength	250Vrms min
Insulation Resistance	> 100MΩ min
Operating Temperature	-40°C to 85°C
Storage Temperature	-40°C to 85°C
Standard Packaging	1000pcs (ammo pack)



MATERIALS ←RoHS COMPLIANT

Actuator	6/6 Nylon
Housing	6/6 Nylon
Cover	Polyester
Contacts	Phosphor Bronze, Silver Plated
Terminals	Brass, Silver Plated

ORDERING INFORMATION

1. Series:	CR1102H	7.0	F160
	CR1102H		
2. Actuator Length "L" (mm):			
	4.3		
	5.0		
	7.0		
	7.3		
	9.5		
3. Actuation Force:			
	F100 = 100gF		
	F160 = 160gF		
	F260 = 260gF		

DIMENSIONS

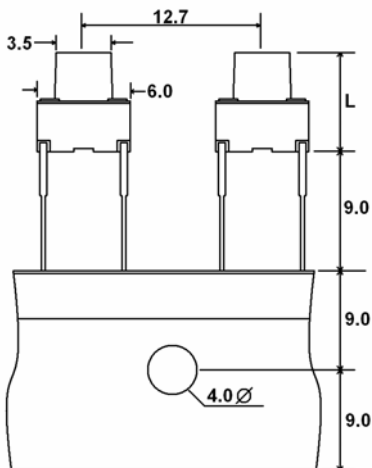

SCHEMATIC & PC LAYOUT

