

# CGA3E1C0G2A682J080AC

TDK Item Description : CGA3E1C0G2A682JT\*\*\*



Equivalent C1608C0G2A682J for Automotive

## Application & Main Feature

Automotive Grade ( Mid Volatage (100 to 630V) )

## Series

CGA3(1608) [EIA 0603]

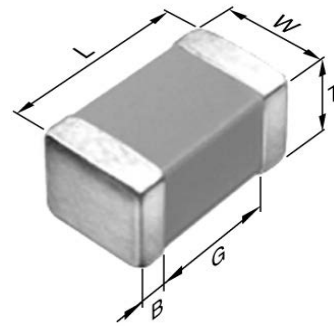

## Dimensions

L	1.60mm +/-0.1mm
W	0.80mm +/-0.1mm
T	0.80mm +/-0.1mm
B	0.20mm Min.
G	0.30mm Min.

## Temperature Characteristic

C0G (-55 to 125 degC 0+/-30ppm/degC)

## Rated Voltage

2A (100Vdc)

## Capacitance

6.8nF

## Capacitance Tolerance

J (+/-5%)

## Q Factor

1000 Min.

## Insulation Resistance

10Gohm Min

## AEC-Q200

Yes

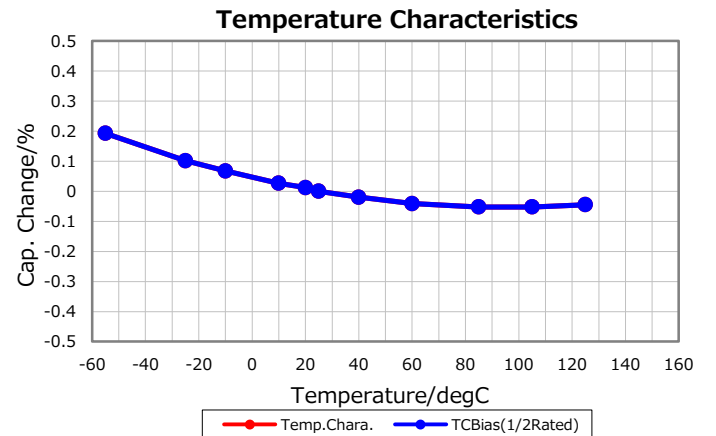
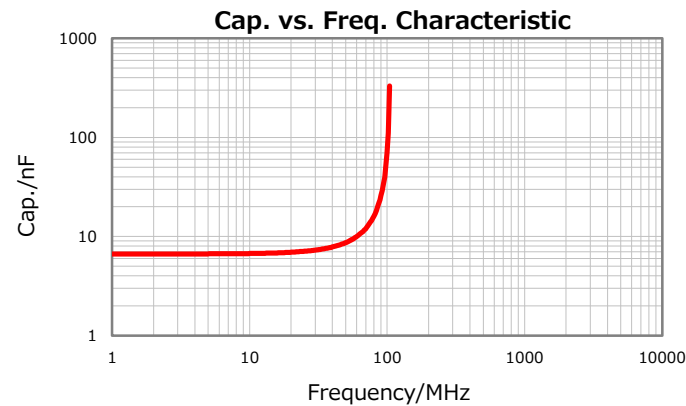
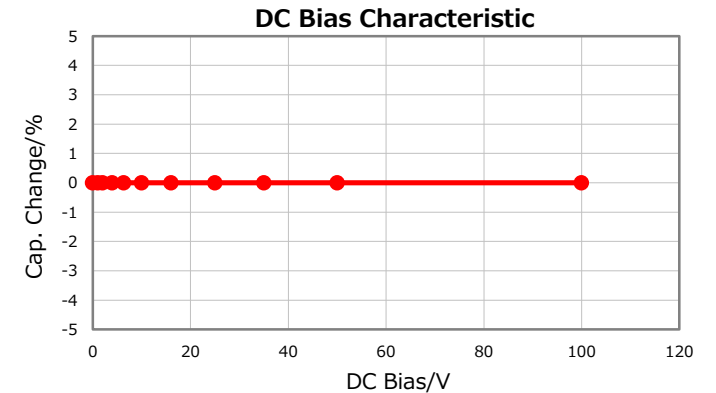
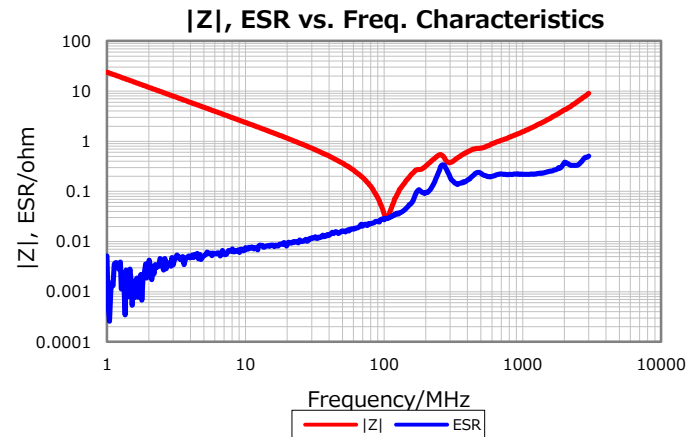

Characterization Sheet ( Multilayer Ceramic Chip Capacitors )



All specifications are subject to change without notice.

July 6, 2016