



Current Sensor

BM14270AMUV-EVK-001 Manual

User's Guide

<High Voltage Safety Precautions>

◇ Read all safety precautions before use

Please note that this document covers only the BM14270AMUV evaluation board (BM14270AMUV-EVK-001) and its functions. For additional information, please refer to the datasheet.

To ensure safe operation, please carefully read all precautions before handling the evaluation board



Depending on the configuration of the board and voltages used,

Potentially lethal voltages may be generated.

Therefore, please make sure to read and observe all safety precautions described in the red box below.

Before Use

- [1] Verify that the parts/components are not damaged or missing (i.e. due to the drops).
- [2] Check that there are no conductive foreign objects on the board.
- [3] Be careful when performing soldering on the module and/or evaluation board to ensure that solder splash does not occur.
- [4] Check that there is no condensation or water droplets on the circuit board.

During Use

- [5] Be careful to not allow conductive objects to come into contact with the board.
- [6] **Brief accidental contact or even bringing your hand close to the board may result in discharge and lead to severe injury or death.**

Therefore, DO NOT touch the board with your bare hands or bring them too close to the board.

In addition, as mentioned above please exercise extreme caution when using conductive tools such as tweezers and screwdrivers.

- [7] If used under conditions beyond its rated voltage, it may cause defects such as short-circuit or, depending on the circumstances, explosion or other permanent damages.
- [8] Be sure to wear insulated gloves when handling is required during operation.

After Use

- [9] The ROHM Evaluation Board contains the circuits which store the high voltage. Since it stores the charges even after the connected power circuits are cut, please discharge the electricity after using it, and please deal with it after confirming such electric discharge.
- [10] Protect against electric shocks by wearing insulated gloves when handling.

This evaluation board is intended for use only in research and development facilities and should be handled **only by qualified personnel familiar with all safety and operating procedures.**

We recommend carrying out operation in a safe environment that includes the use of high voltage signage at all entrances, safety interlocks, and protective glasses.

Current Sensor

BM14270AMUV-EVK-001 Manual

BM14270AMUV-EVK-001 is an evaluation board for BM14270AMUV, which is a ROHM Current Sensor. This User's Guide is about how to use BM14270AMUV-EVK-001 together with SensorShield that is sold as Shield-EVK-001.

Preparation

- Arduino Uno 1pc
- Personal Computer installed Arduino IDE 1pc
 - Requirement : Arduino 1.6.7 or higher
 - Please use Arduino IDE which can be downloaded from the link below: <http://www.arduino.cc/>
- USB cable for connecting Arduino and PC 1pc
- SensorShield 1pc
- BM14270AMUV-EVK-001 1pc

Setting

1. Connect the Arduino and the SensorShield (Figure 1)

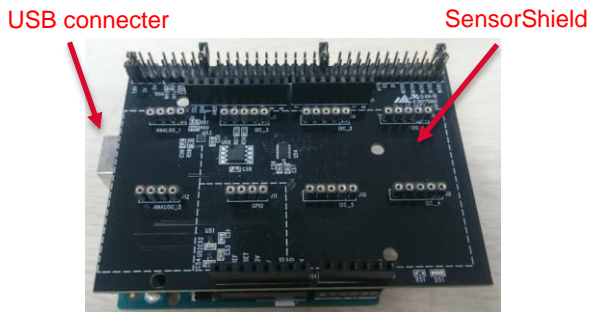

Figure 1. Connection between the Arduino and the SensorShield

2. Connect BM14270AMUV-EVK-001 to the socket of I2C area on the SensorShield (Figure 2)
3. Set Voltage of the SensorShield to 3.0V (Figure 2)
4. Set Interrupt pin to INTR1 (Figure 2)

3 Voltage setting pin

4 Interrupt pin

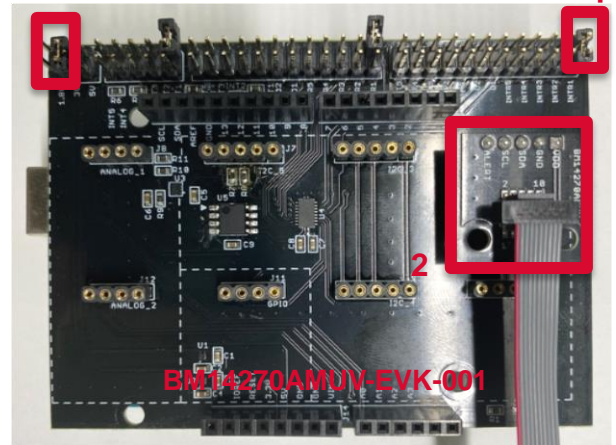

Figure 2. Connection between BM14270AMUV-EVK-001 and the SensorShield

5. Connect the Arduino to the PC using a USB cable
6. Download BM14270AMUV.zip from the link below: <http://www.rohm.com/web/global/sensor-shield-support> (Software is subject to change without no notice.)
7. Launch Arduino IDE
8. Select [Sketch]->[Include Library]->[Add.ZIP library...], install BM14270AMUV.zip
9. Select [File]->[Examples]->[BM14270AMUV]->[example]-> [BM14270AMUV]

Measurement

1. Select [Tools] and check the contents enclosed in the red frame. (Figure 3) Board should be "Arduino/Genuino Uno" and Port should be COMxx (Arduino/Genuino Uno). COM port number is different in each environment.

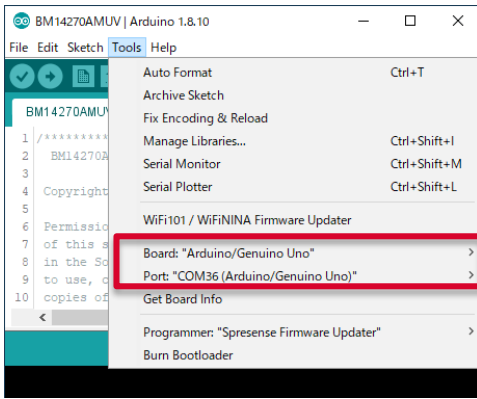

Figure 3. Board and COM Port setting

2. Write the program by pressing right arrow button for upload (Figure 4)
3. Wait for the message "Done uploading" (Figure 4)

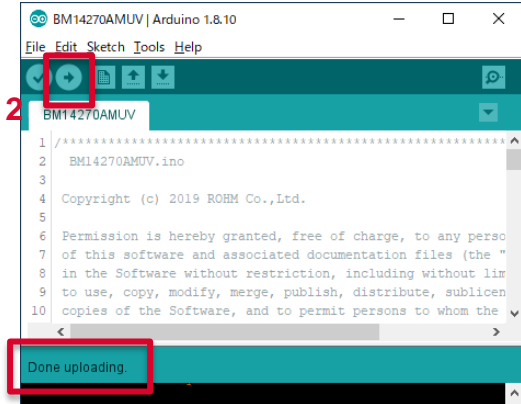

Figure 4. Uploading

4. Select [Tools]->[Serial Monitor] (Figure 5)

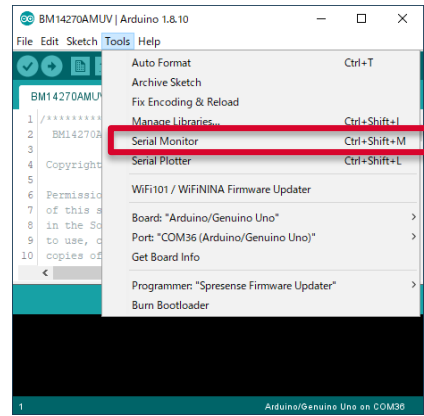

Figure 5. Tools Setting

5. Set baudrate to 115200 and check log of Serial Monitor (Figure 6)

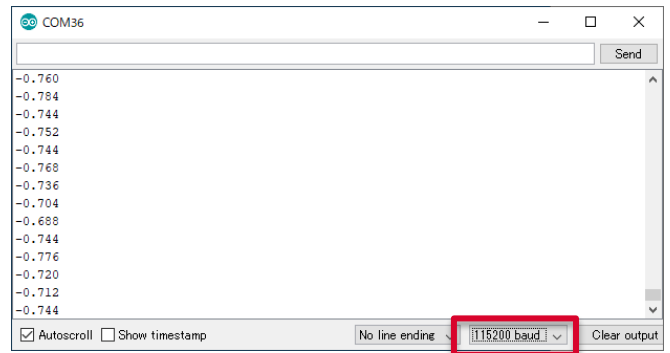

Figure 6. Serial Monitor

6. Set the board between current line (Figure 7)

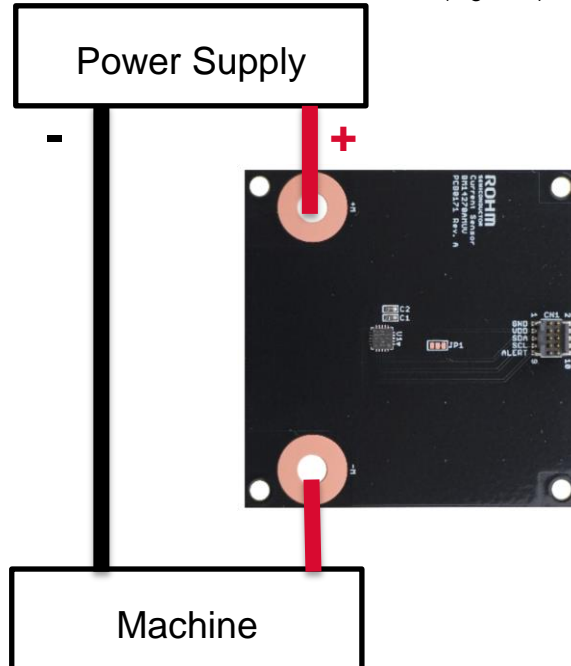

Figure 7. Connection board example

Board Information

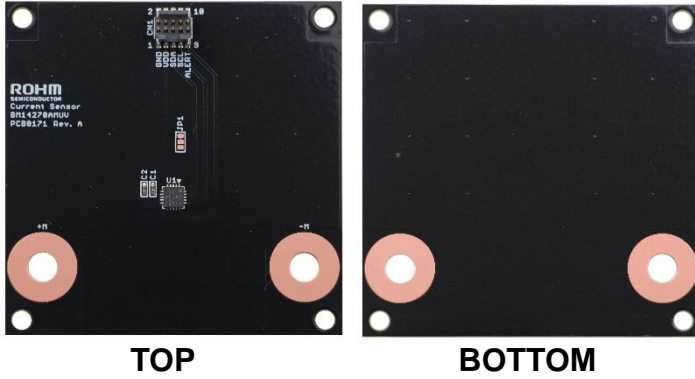

Figure 8. Picture of the current sensor board

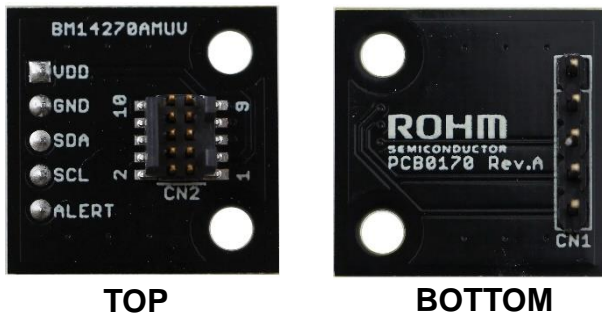

Figure 9. Picture of the current sensor board

Parts number	Function
C1	Bypass capacitor for VDD (0.22uF)
C2	Bypass capacitor for VREG (0.22)
A2	PAD to change slave address : Default = L (GND)

Table 1. The current sensor board parts information

Notes

- 1) The information contained herein is subject to change without notice.
- 2) Before you use our Products, please contact our sales representative and verify the latest specifications :
- 3) Although ROHM is continuously working to improve product reliability and quality, semiconductors can break down and malfunction due to various factors.
Therefore, in order to prevent personal injury or fire arising from failure, please take safety measures such as complying with the derating characteristics, implementing redundant and fire prevention designs, and utilizing backups and fail-safe procedures. ROHM shall have no responsibility for any damages arising out of the use of our Products beyond the rating specified by ROHM.
- 4) Examples of application circuits, circuit constants and any other information contained herein are provided only to illustrate the standard usage and operations of the Products. The peripheral conditions must be taken into account when designing circuits for mass production.
- 5) The technical information specified herein is intended only to show the typical functions of and examples of application circuits for the Products. ROHM does not grant you, explicitly or implicitly, any license to use or exercise intellectual property or other rights held by ROHM or any other parties. ROHM shall have no responsibility whatsoever for any dispute arising out of the use of such technical information.
- 6) The Products specified in this document are not designed to be radiation tolerant.
- 7) For use of our Products in applications requiring a high degree of reliability (as exemplified below), please contact and consult with a ROHM representative : transportation equipment (i.e. cars, ships, trains), primary communication equipment, traffic lights, fire/crime prevention, safety equipment, medical systems, servers, solar cells, and power transmission systems.
- 8) Do not use our Products in applications requiring extremely high reliability, such as aerospace equipment, nuclear power control systems, and submarine repeaters.
- 9) ROHM shall have no responsibility for any damages or injury arising from non-compliance with the recommended usage conditions and specifications contained herein.
- 10) ROHM has used reasonable care to ensure the accuracy of the information contained in this document. However, ROHM does not warrants that such information is error-free, and ROHM shall have no responsibility for any damages arising from any inaccuracy or misprint of such information.
- 11) Please use the Products in accordance with any applicable environmental laws and regulations, such as the RoHS Directive. For more details, including RoHS compatibility, please contact a ROHM sales office. ROHM shall have no responsibility for any damages or losses resulting non-compliance with any applicable laws or regulations.
- 12) When providing our Products and technologies contained in this document to other countries, you must abide by the procedures and provisions stipulated in all applicable export laws and regulations, including without limitation the US Export Administration Regulations and the Foreign Exchange and Foreign Trade Act.
- 13) This document, in part or in whole, may not be reprinted or reproduced without prior consent of ROHM.



Thank you for your accessing to ROHM product informations.
More detail product informations and catalogs are available, please contact us.

ROHM Customer Support System

<http://www.rohm.com/contact/>