

Type AVGA $-40\text{ }^{\circ}\text{C}$ to $+105\text{ }^{\circ}\text{C}$

High Capacitance SMT Aluminum Electrolytic Capacitors

For Filtering, Bypassing and Power Supply Decoupling with High Capacitance Requirements

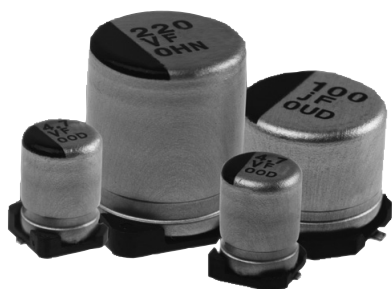

Type AVGA Capacitors are rated for 2000 hours at $105\text{ }^{\circ}\text{C}$ and up to 63 Vdc. They are ideal for high density PC board packaging. The Type AVGA offers a low in-place-cost for a high quality performer. The vertical cylindrical cases facilitate automatic mounting and reflow soldering into the same footprint of like-rated tantalum capacitors except without the need for voltage derating. Type AVGA is RoHS compliant.

Highlights

- $+105\text{ }^{\circ}\text{C}$, Up to 2000 Hours Load Life
- Capacitance Range: $0.1\text{ }\mu\text{F}$ to $4700\text{ }\mu\text{F}$
- Voltage Range: 6.3 Vdc to 63 Vdc

Specifications

- Operating Temperature:** $-40\text{ }^{\circ}\text{C}$ to $+105\text{ }^{\circ}\text{C}$
Rated Voltage: 6.3, 10, 16, 25, 35, 50, 63 Vdc
Capacitance: $0.1\text{ }\mu\text{F}$ to $4700\text{ }\mu\text{F}$
Capacitance Tolerance: $\pm 20\%$ @ 120 Hz and $+20\text{ }^{\circ}\text{C}$

Leakage Current (at $20\text{ }^{\circ}\text{C}$):

6.3 – 63 V	4 – 10 \emptyset	$I = 0.01\text{ CV}$ or $3\text{ }\mu\text{A}$, whichever is greater, after 2 minutes at $+20\text{ }^{\circ}\text{C}$
	12.5 ~ 16 \emptyset	$I = 0.03\text{ CV}$ or $4\text{ }\mu\text{A}$, whichever is greater, after 2 minutes at $+20\text{ }^{\circ}\text{C}$

I = leakage current C = rated capacitance in μF V = rated DC Working voltage in V

Dissipation Factor: ($\text{Tan } \delta$ at 120 Hz, $20\text{ }^{\circ}\text{C}$)

Rated Voltage	63	10	16	25	35	50	63
4 ~ 10 \emptyset	0.45	0.35	0.28	0.18	0.16	0.14	0.12
12.5 ~ 16 \emptyset	0.4	0.38	0.34	0.26	0.22	0.18	0.14

When the capacitance exceeds $1000\text{ }\mu\text{F}$, .02 shall be added for every $1000\text{ }\mu\text{F}$ increase

Low Temperature Characteristic (at 120 Hz):

		Rated Voltage		6.3	10	16	25	35	50	63
Impedance Ratio	Z($-25\text{ }^{\circ}\text{C}$)	4 ~ 10 \emptyset	4	3	2	2	2	2	2	2
	/Z($+20\text{ }^{\circ}\text{C}$)	12.5 ~ 16 \emptyset	5	4	3	2	2	2	2	2
	Z($-40\text{ }^{\circ}\text{C}$)	4 ~ 10 \emptyset	12	8	6	4	3	3	3	3
	/Z($+20\text{ }^{\circ}\text{C}$)	12.5 ~ 16 \emptyset	10	8	6	4	3	3	3	3

Impedance ratio shall not exceed the values given in the table above.

Load Life Test:

Test Time	2,000 Hours
Capacitance Change	4 ~ 6.3 \emptyset : Within $\pm 25\%$ of initial value
	8 ~ 16 \emptyset : Within $\pm 20\%$ of initial value
Dissipation Factor	< 200% of specified value
Leakage Current	Within specified value

* The above specifications shall be satisfied when the capacitors are restored to $20\text{ }^{\circ}\text{C}$ after the rated voltage is applied for 2,000 hrs at $105\text{ }^{\circ}\text{C}$

Shelf Life Test: Test time: 1000 hours; other items are the same as those for life test.

Complies with the EU Directive 2002/95/EC requirement restricting the use of Lead (Pb), Mercury (Hg), Cadmium (Cd), Hexavalent chromium (Cr(VI)), PolyBrominated Biphenyls (PBB) and PolyBrominated Diphenyl Ethers (PBDE).



Type AVGA $-40\text{ }^{\circ}\text{C}$ to $+105\text{ }^{\circ}\text{C}$

High Capacitance SMT Aluminum Electrolytic Capacitors

Outline Drawings, Case Code & Dimensions Table

Fig. 1

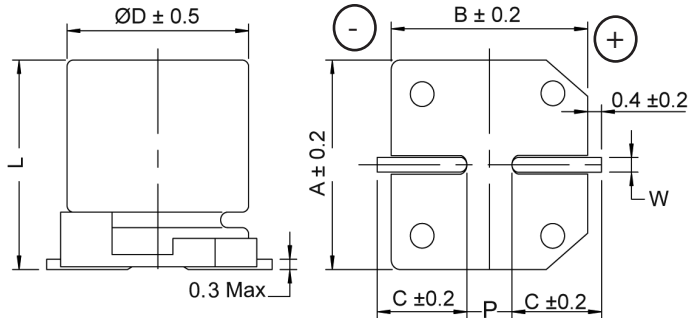
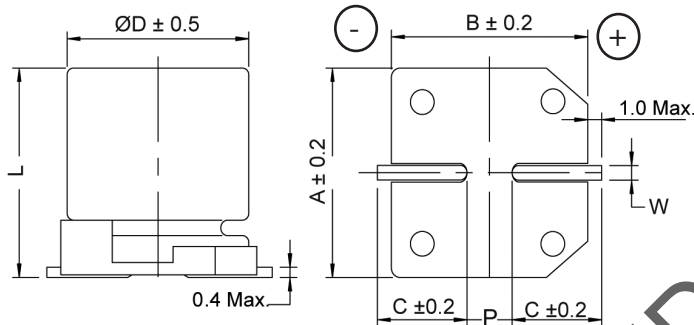

Fig. 2



Case Code	Ø D (mm)	L (mm)	A (mm)	B (mm)	C (mm)	W (mm)	P ±0.2 (mm)	Fig. No.
B	4.0	5.7 ±0.3	4.3	4.3	2.0	0.5 to 0.8	1.0	1
C	5.0	5.7 ±0.3	5.3	5.3	2.3	0.5 to 0.8	1.5	1
D	6.3	5.7 ±0.3	6.6	6.6	2.7	0.5 to 0.8	2.0	1
X	6.3	7.7 ±0.3	6.6	6.6	2.7	0.5 to 0.8	2.0	1
F	8.0	10 ±0.5	8.4	8.4	3.0	0.7 to 1.1	3.1	1
G	10.0	10 ±0.5	10.4	10.4	3.3	0.7 to 1.1	4.7	1
Q	10.0	10.3 ±0.5	10.4	10.4	3.3	0.7 to 1.1	4.7	1
H	12.5	13.5 ±0.5	12.8	12.8	4.9	1.1 to 1.4	4.2	2
L	12.5	16 ±0.5	12.8	12.8	4.9	1.1 to 1.4	4.2	2
P	16.0	16.5 ±0.5	16.3	16.3	5.8	1.1 to 1.4	6.0	2

Part Numbering System

AVGA	227	M	25	F	24T	-F
Type	Capacitance	Capacitance Tolerance	Voltage Code	Case Code	Packaging Code	RoHs Compliant
AVGA	104 = .1 µF 475 = 4.7 µF 106 = 10.0 µF 227 = 220 µF 478 = 4700 µF	M = ±20%	06 = 6.3 Vdc 10 = 10 Vdc 16 = 16 Vdc 25 = 25 Vdc 35 = 35 Vdc 50 = 50 Vdc 63 = 63 Vdc	See Table	24 = Carrier tap Width (mm) T = Tape & Reel Y = Tray Pack (available for H,L, & P case codes)	

Type AVGA -40 °C to +105 °C

High Capacitance SMT Aluminum Electrolytic Capacitors

Ratings

Cap (µF)	Catalog Part Number	Max. DCL (µA)	Max. DF @ 120 Hz	Max. ESR @ 120 Hz/20 °C (ohms)	Max. Ripple Current @ 120 Hz/105 °C (ma)	Case Code	Size D x L (mm)	Quantity Per Reel (ea)
6.3 Vdc (8 Vdc Surge)								
47	AVGA476M06C12T-F	3.0	0.45	15.87	30	C	5x5.7	1000
100	AVGA107M06D16T-F	6.3	0.45	7.46	69	D	6.3x5.7	1000
220	AVGA227M06X16T-F	14	0.45	3.39	120	X	6.3x7.7	1000
330	AVGA337M06F24T-F	21	0.45	2.26	290	F	8x10	500
470	AVGA477M06F24T-F	30	0.45	1.59	320	F	8x10	500
1000	AVGA108M06G24T-F	63	0.45	0.75	410	G	10x10	500
2200	AVGA228M06H32T-F	416	0.42	0.32	680	H	12.5x13.5	200
3300	AVGA338M06L32T-F	624	0.44	0.22	850	L	12.5x16	150
4700	AVGA478M06P44T-F	888	0.46	0.16	1000	P	16x16.5	125
10 Vdc (13 Vdc Surge)								
33	AVGA336M10C12T-F	3.3	0.35	17.58	30	C	5x5.7	1000
47	AVGA476M10D16T-F	4.7	0.35	12.35	48	D	6.3x5.7	1000
100	AVGA107M10D16T-F	10	0.35	5.80	69	D	6.3x5.7	1000
220	AVGA227M10X16T-F	22	0.35	2.64	120	X	6.3x7.7	1000
330	AVGA337M10F24T-F	33	0.35	1.76	290	F	8x10	500
470	AVGA477M10F24T-F	47	0.35	1.23	320	F	8x10	500
470	AVGA477M10G24T-F	47	0.35	1.23	410	G	10x10	500
1000	AVGA108M10Q24T-F	100	0.35	0.58	410	Q	10x10.3	500
2200	AVGA228M10L32T-F	660	0.40	0.30	750	L	12.5x16	150
3300	AVGA338M10P44T-F	990	0.42	0.21	1000	P	16x16.5	125
4700	AVGA478M10P44T-F	1410	0.44	0.16	1000	P	16x16.5	125
16 Vdc (20 Vdc Surge)								
10	AVGA106M16B12T-F	3.0	0.28	46.42	17	B	4x5.7	2000
22	AVGA226M16C12T-F	3.5	0.28	21.10	30	C	5x5.7	1000
33	AVGA336M16D16T-F	5.3	0.28	14.07	45	D	6.3x5.7	1000
47	AVGA476M16D16T-F	7.5	0.28	9.88	48	D	6.3x5.7	1000
100	AVGA107M16D16T-F	10	0.28	4.64	69	D	6.3x5.7	1000
220	AVGA227M16X16T-F	22	0.28	2.11	120	X	6.3x7.7	1000
330	AVGA337M16F24T-F	33	0.28	1.41	290	F	8x10	500
470	AVGA477M16F24T-F	47	0.28	0.99	320	F	8x10	500
1000	AVGA108M16H32T-F	100	0.34	0.56	550	H	12.5x13.5	200
2200	AVGA228M16P44T-F	1056	0.36	0.27	950	P	16x16.5	125
3300	AVGA338M16P44T-F	1584	0.38	0.19	950	P	16x16.5	125
25 Vdc (32 Vdc Surge)								
4.7	AVGA475M25B12T-F	3.0	0.18	63.49	13	B	4x5.7	2000
10	AVGA106M25C12T-F	3.0	0.18	29.84	23	C	5x5.7	1000
22	AVGA226M25D16T-F	5.5	0.18	13.56	38	D	6.3x5.7	1000
33	AVGA336M25D16T-F	8.3	0.18	9.04	50	D	6.3x5.7	1000
47	AVGA476M25D16T-F	12	0.18	6.35	60	D	6.3x5.7	1000
100	AVGA107M25X16T-F	25	0.18	2.98	100	X	6.3x7.7	1000
220	AVGA227M25F24T-F	55	0.18	1.36	320	F	8x10	500
330	AVGA337M25G24T-F	83	0.18	0.90	375	G	10x10	500
470	AVGA477M25G24T-F	118	0.18	0.64	410	G	10x10	500
1000	AVGA108M25L32T-F	750	0.26	0.43	550	L	12.5x16	150
2200	AVGA228M25P44T-F	1650	0.28	0.21	820	P	16x16.5	125

Contact factory for tray pack (Y) quantities

Type AVGA -40 °C to +105 °C

High Capacitance SMT Aluminum Electrolytic Capacitors

Cap (µF)	Catalog Part Number	Max. DCL (µA)	Max. DF @ 120 Hz	Max. ESR @ 120 Hz/20 °C (ohms)	Max. Ripple Current @ 120 Hz/105 °C (ma)	Case Code	Size D x L (mm)	Quantity Per Reel (ea)
35 Vdc (44 Vdc Surge)								
4.7	AVGA475M35B12T-F	3.0	0.16	56.44	16	B	4x5.7	2000
10	AVGA106M35C12T-F	3.5	0.16	26.53	27	C	5x5.7	1000
22	AVGA226M35D16T-F	7.7	0.16	12.06	44	D	6.3x5.7	1000
33	AVGA336M35D16T-F	12	0.16	8.04	54	D	6.3x5.7	1000
47	AVGA476M35X16T-F	16	0.16	5.64	80	X	6.3x7.7	1000
100	AVGA107M35F24T-F	35	0.16	2.65	320	F	8x10	500
220	AVGA227M35G24T-F	77	0.16	1.21	375	G	10x10	500
330	AVGA337M35Q24T-F	116	0.16	0.80	410	Q	10x10.3	500
470	AVGA477M35H32T-F	494	0.22	0.78	520	H	12.5x13.5	200
1000	AVGA108M35P44T-F	1050	0.22	0.36	750	P	16x16.5	125
50 Vdc (63 Vdc Surge)								
0.1	AVGA104M50B12T-F	3.0	0.14	2320.96	2	B	4x5.7	2000
0.22	AVGA224M50B12T-F	3.0	0.14	1054.98	3	B	4x5.7	2000
0.33	AVGA334M50B12T-F	3.0	0.14	703.32	4	B	4x5.7	2000
0.47	AVGA474M50B12T-F	3.0	0.14	493.82	5	B	4x5.7	2000
1.0	AVGA105M50B12T-F	3.0	0.14	232.10	10	B	4x5.7	2000
2.2	AVGA225M50B12T-F	3.0	0.14	105.50	16	B	4x5.7	2000
3.3	AVGA335M50B12T-F	3.0	0.14	70.33	18	B	4x5.7	2000
4.7	AVGA475M50C12T-F	3.0	0.14	49.38	20	C	5x5.7	1000
10	AVGA106M50D16T-F	5.0	0.14	23.21	32	D	6.3x5.7	1000
22	AVGA226M50D16T-F	11	0.14	10.55	47	D	6.3x5.7	1000
33	AVGA336M50X16T-F	17	0.14	7.03	65	X	6.3x7.7	1000
47	AVGA476M50X16T-F	24	0.14	4.94	80	X	6.3x7.7	1000
100	AVGA107M50F24T-F	50	0.14	2.32	230	F	8x10	500
100	AVGA107M50G24T-F	50	0.14	2.32	375	G	10x10	500
220	AVGA227M50Q24T-F	110	0.14	1.06	375	Q	10x10.3	500
330	AVGA337M50H32T-F	165	0.18	0.90	500	H	12.5x13.5	200
470	AVGA477M50L32T-F	235	0.18	0.64	550	L	12.5x16	150
63 Vdc (79 Vdc Surge)								
0.47	AVGA474M63B12T-F	3.0	0.12	423.27	5	B	4x5.7	2000
1	AVGA105M63B12T-F	3.0	0.12	198.94	8	B	4x5.7	2000
2.2	AVGA225M63B12T-F	3.0	0.12	90.43	12	B	4x5.7	2000
3.3	AVGA335M63C12T-F	3.0	0.12	60.28	17	C	5x5.7	1000
4.7	AVGA475M63D16T-F	3.0	0.12	42.33	22	D	6.3x5.7	1000
10	AVGA106M63D16T-F	6.3	0.12	19.89	32	D	6.3x5.7	1000
22	AVGA226M63X16T-F	14	0.12	9.04	58	X	6.3x7.7	1000
33	AVGA336M63F24T-F	21	0.12	6.03	140	F	8x10	500
47	AVGA476M63F24T-F	30	0.12	4.23	170	F	8x10	500
47	AVGA476M63G24T-F	30	0.12	4.23	310	G	10x10	500
100	AVGA107M63Q24T-F	63	0.12	1.99	310	Q	10x10.3	500
220	AVGA227M63H32T-F	416	0.14	1.06	470	H	12.5x13.5	200
330	AVGA337M63P44T-F	624	0.14	0.70	700	P	16x16.5	125
470	AVGA477M63P44T-F	888	0.14	0.49	700	P	16x16.5	125

Contact factory for tray pack (Y) quantities

Type AVGA $-40\text{ }^{\circ}\text{C}$ to $+105\text{ }^{\circ}\text{C}$

High Capacitance SMT Aluminum Electrolytic Capacitors

Recommended Land Patterns by case size for AVGA series

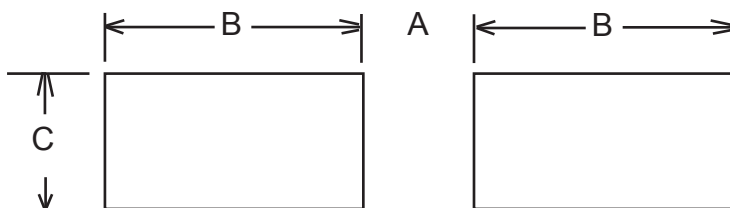

Case Code	Case Size	Land Dimensions (mm)		
	4x5.7	1.6	2.6	1
C	5x5.7	1.6	3	1.4
D	6.3x5.7	1.6	3.5	1.9
X	6.3x7.7	1.6	3.5	1.9
F	8x10	2.5	3.5	3
G	10x10	2.5	4	4
Q	10x10.3	2.5	4	4
H	12.5x13.5	4	7.5	7
L	12.5x16	4	7.5	7
P	16x16.5	6	8.5	9.5

Type AVGA $-40\text{ }^{\circ}\text{C}$ to $+105\text{ }^{\circ}\text{C}$

High Capacitance SMT Aluminum Electrolytic Capacitors Recommended Soldering Methods

Recommended Reflow Soldering Profile:

For case diameters
4 thru 6.3 mm with voltage
ratings of 6.3 to 50Vdc

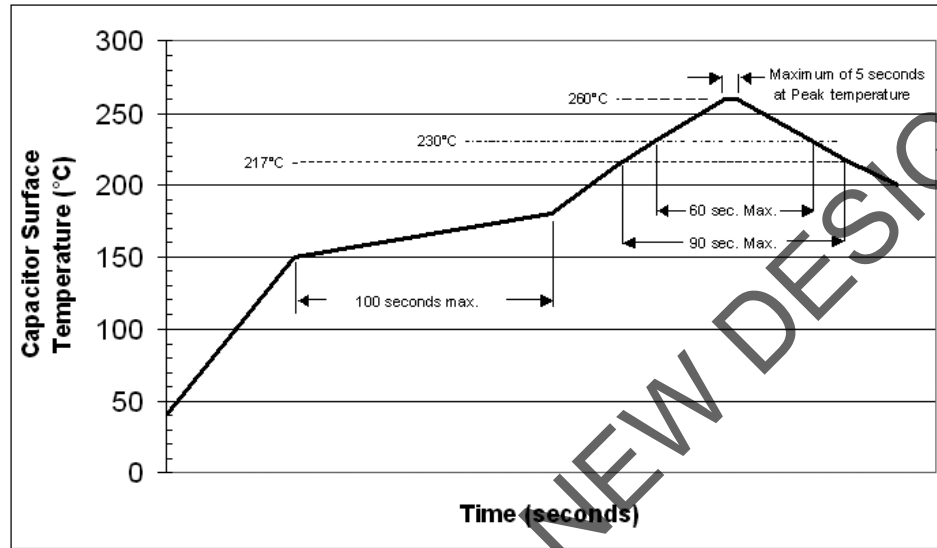

For case diameters
4 thru 6.3 mm with a volt-
age rating of 63 Vdc

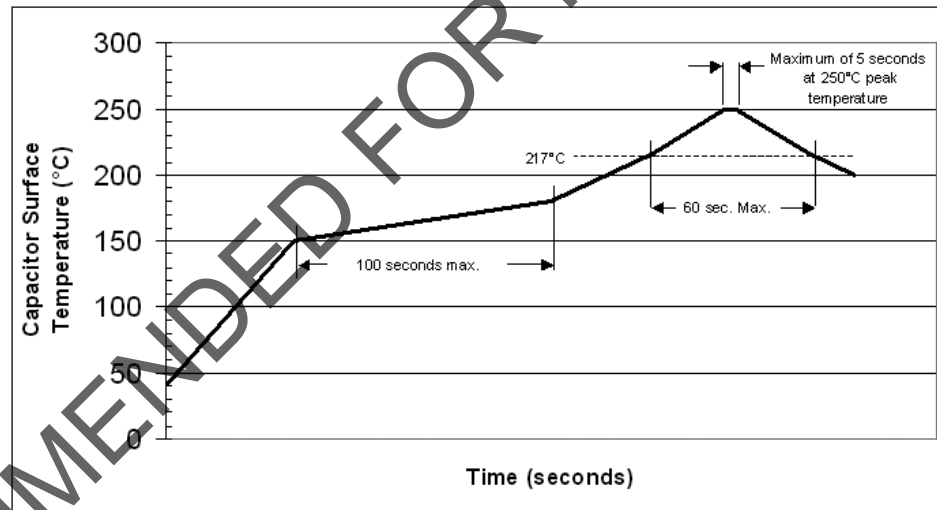

For case diameters
8 to 16 mm

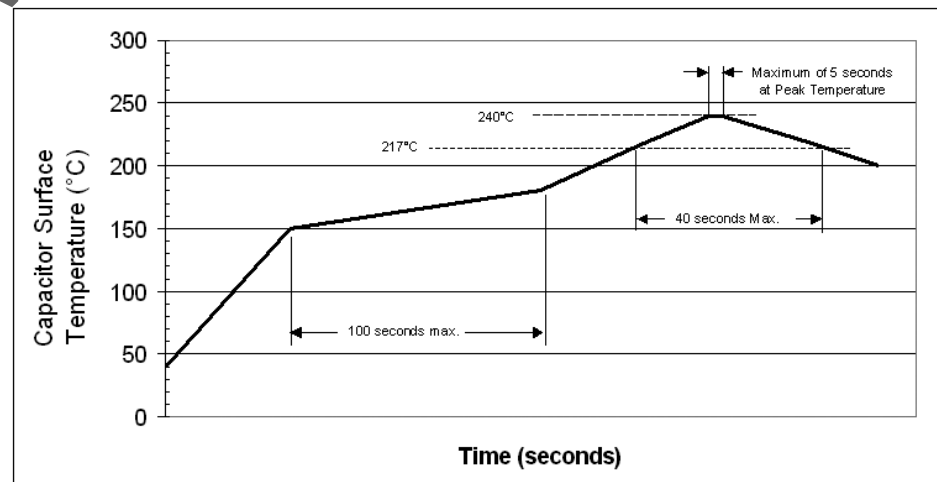

Case sizes 4 thru 6.3 mm dia. (4 to 50V) should be subjected to just one reflow soldering process.

The 8 thru 16 mm dia. case sizes (and 4 thru 6.3 mm dia. at 63V) should be subjected to a maximum of two reflow soldering processes.

Soldering with a solder iron should be performed with a maximum soldering iron tip temperature of $350\pm 5\text{ }^{\circ}\text{C}$ for 3 to 4 seconds.