



Technical Data Sheet

Alpha 40



Alpha 40 is a compact multifunction instrument which is especially designed for Active, Reactive and Apparent Energy Measurement including per phase THD, Powers and others parameters as per different models.

Special Features

- True RMS Measurement
- Energy as per IEC 62053
- Onsite Programmable
- Low Back Depth
- Error Diagnosis Mode
- LCD Display with Back-lit
- RS-485, Limit or Pulse Output

Application

Alpha 40 measures important electrical parameters in 3 phase and single phase Network & replaces the multiple analog panel meters. It measures electrical parameters like Active / Reactive / Apparent energy & power as per models. The instrument has optional output as one pulse output for energy measurement. it is also applicable for **Energy billing, Electrical load monitoring, Sub-metering, Genset, Test Benches and Laboratories.**

Product Features

True RMS measurement	Measures distorted waveform up to 15th Harmonic.	Configurable Error Diagnosis Mode	Incorrect phase sequence, phase reversal and phase missing error detection.
Energy as per IEC 62053	Independent Import and Export Energy counter. Active energy (kWh), Reactive energy (kVARh), Apparent energy (kVAh) measurement. Accuracy as per IEC 62053-21, IEC62053-23.	LCD Display with Backlit	LCD shows 3 Parameters at a glance.
THD Measurement	The instrument measures THD per phase voltage & current.	Parameter Screen recall	In case of power failure, the instrument memorizes the last displayed screen.
On-site programmable	Onsite Programmable System Configuration 3PH4W / 3PH3W / 1PH2W. Onsite Programmable CT ratios and PT ratios	Hour Run, ON Hour, Number of Interruptions	Hour run records the number of hours load is connected. ON Hour is the period for which the auxiliary supply is ON. Number of Interruptions indicates the number of times the Auxiliary Supply was interrupted.
Direct remote access(Optional)	Remote configuration of the Instrument via MODBUS. Remote access of measured parameters. Programmable baud rates up to 38.4kbps.	Onsite selection of Auto scroll / Fixed Screen	User can set the display in auto scrolling mode or fixed screen mode locally via front panel keys by entering into Programming mode or remotely via MODBUS (RS-485).
Limit (Alarm) or Pulse Relay Output (Optional)	Potential free, very fast acting relay contact. Configurable as pulse output which can be used to drive an external counter for energy measurement. Configurable as limit (alarm) switch.	Enclosure Protection for dust and water	Conforms to IP 54 (front face) as per IEC60529
Low back depth	The instrument has very low back depth (behind the panel) of less than 35 mm.	Compliance to International Safety standards	Compliance to International Safety standard IEC 61010-1- 2010
		EMC Compatibility	Compliance to International standard IEC 61326

Technical Specifications

Accuracy	
Reference Conditions (As per IEC 62053 - 21)	23°C +/- 2°C
Active Energy	Class 1 as per IEC 62053 - 21
Reactive Energy	Class 2 as per IEC 62053 - 23
Apparent Energy	Class 1
Active Power	±0.5% of nominal value at $\cos \phi = 1$
Re-Active Power	±0.5% of nominal value at $\cos \phi = 1$
Apparent Power	±0.5% of nominal value at $\cos \phi = 1$
Power Factor	±3°
Voltage	±0.5% of nominal value
Current	±0.5% of nominal value
Frequency	± 0.2% of mid frequency
THD (Voltage / Current)	±1.0%

Input Voltage

Nominal input voltage (AC RMS)	Phase -Neutral	Line-Line
	63.5 VL-N	110 VL-L
133 VL-N	230 VL-L	
239.6 VL-N	415 VL-L	
254 VL-N	440 VL-L	
289 VL-N	500 VL-L	
System PT primary values	100VLL to 692kVLL programmable on site.	
Max continuous input voltage	120% of nominal value	

Input Current

Nominal input current	1A/5A AC RMS (to be specified while ordering).
System CT primary values	From 1A up to 9999A
Max continuous input current	120% of nominal value

Auxiliary Supply

External Aux	60 V - 300V AC-DC
Aux supply frequency	45 to 65 Hz range

Environmental

Operating temperature	-20 to +70°C
Storage temperature	-30 to +80°C
Relative humidity	0... 95% non condensing
Warm up time	Minimum 3 minute
Shock	15g in 3 planes
Vibration	10... 55...10 Hz, 0.15mm amplitude

Dimension Details

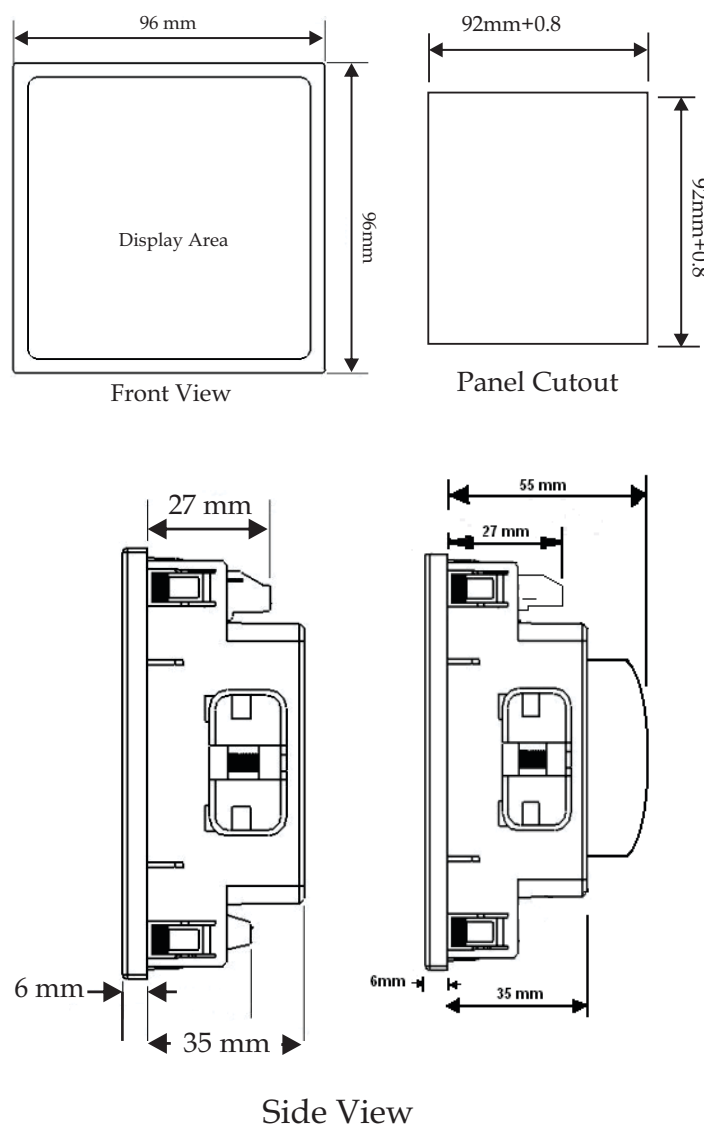

Technical Specifications

PT Secondary Ranges for Various Input Voltage

Input Voltage	PT Secondary Settable Range
110V L-L (63.5V L-N)	100V - 120V L-L (57V - 69V L-N)
230V L-L (133V L-N)	121V - 239V L-L (70V - 139V L-N)
415V L-L (239.6V L-N)	240V - 480V L-L (140V - 277V L-N)

It is recommended that the wires used for connections to the instrument should have lugs soldered at the end. That is, the connections should be made with Lugged wires for secure connections. The Maximum diameter of the lug should be 7.0 mm and maximum thickness 3.5mm. Permissible cross section of the connections wires: ≤ 4.0 mm sq. single wire or 2x2.5mm sq. fine wire

Technical Specifications

VA Burden	
Nominal input voltage burden	< 0.2 VA approx. per phase burden
Nominal input current burden	< 0.6 VA approx. per phase burden
Auxiliary Supply burden	< 4 VA approx

Overload Withstand	
Voltage	2 x rated value for 1 second, repeated 10 times at 10 second intervals
Current	20x rated value for 1 second, repeated 5 times at 5 min intervals

Operating Measuring Ranges	
Current (Energy Measurement)	Starting current : 2mA for 1A & 10mA for 5A Range: 20mA to 1.2A for 1A 100mA to 6A for 5A
Voltage	10... 120% of nominal value
Power Factor	0.5 Lag ... 1... 0.8 Lead
Frequency	50Hz / 60Hz

Display update rate	
Response time to step input	1 sec approx.

Applicable Standards	
EMC	IEC 61326
Immunity	IEC 61000-4-3. 10V/m min - Level 3 industrial Low level
Safety	IEC 61010-1-2010 , Permanently connected use
IP for water & dust	IEC60529
Pollution degree	2
Installation category	III
High Voltage Test	3.2 kV DC, for 1 minute between all Electrical circuits.

Interfaces	
Impulse Led	For Energy Calibration at front
Relay(Optional)	240 VDC ,5 A Configured as Limit or Pulse output
ModBus(Optional)	RS485,max. 1200m Baud rate: 4.8k,9.6k, 19.2k, 38.4k bps

Installation

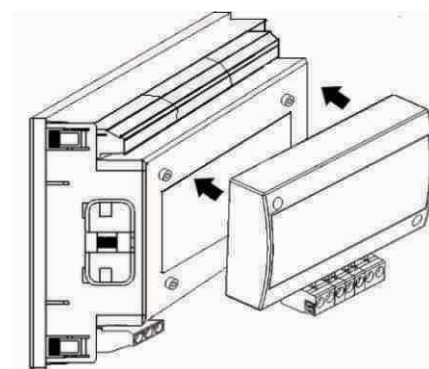
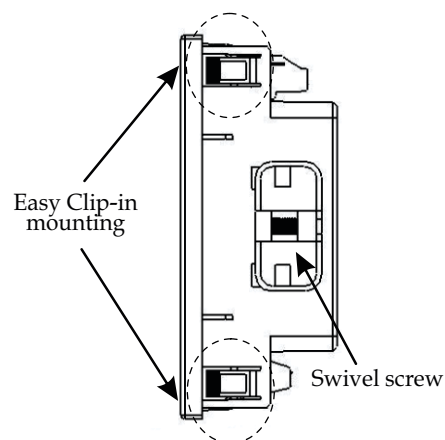

Optional Modbus/Pulse output pluggable module.

Electrical Connection

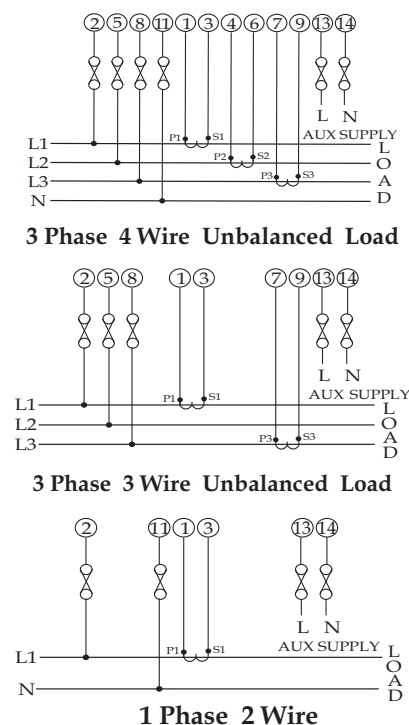

Measured Parameter System wise

Sr No	Displayed Parameters	3 Phase 4Wire	3Phase 3Wire	1PH 2W
1.	Import Active Energy (kWh)	✓	✓	✓
2.	Export Active Energy (kWh)	✓	✓	✓
3.	Inductive Reactive Energy (kVARh)	✓	✓	✓
4.	Capacitive Reactive Energy (kVARh)	✓	✓	✓
5.	Apparent Energy (Vah)	✓	✓	✓
6.	System Active Power (kW)	✓	✓	✓
7.	Active Power L1 (kW)	✓	✗	✗
8.	Active Power L2 (kW)	✓	✗	✗
9.	Active Power L3 (kW)	✓	✗	✗
10.	System Re-active Power (kVAR)	✓	✓	✓
11.	Re-active Power L1 (kVAR)	✓	✗	✗
12.	Re-active Power L2 (kVAR)	✓	✗	✗
13.	Re-active Power L3 (kVAR)	✓	✗	✗
14.	System Apparent Power (kVA)	✓	✓	✓
15.	Apparent Power L1 (kVA)	✓	✗	✗
16.	Apparent Power L2 (kVA)	✓	✗	✗
17.	Apparent Power L3 (kVA)	✓	✗	✗
18.	System Power Factor	✓	✓	✓
19.	Power Factor L1	✓	✗	✗
20.	Power Factor L2	✓	✗	✗
21.	Power Factor L3	✓	✗	✗
22.	Current Demand	✓	✓	✓
23.	kVA Demand	✓	✓	✓
24.	Import kW Demand	✓	✓	✓
25.	Export kW Demand	✓	✓	✓
26.	Run Hour	✓	✓	✓
27.	On Hour	✓	✓	✓
28.	Number of Interruptions	✓	✓	✓
29.	System Voltage	✓	✓	✓
30.	Voltage L1	✓	✗	✗
31.	Voltage L2	✓	✗	✗
32.	Voltage L3	✓	✗	✗
33.	Voltage L12	✓	✓	✗
34.	Voltage L23	✓	✓	✗
35.	Voltage L31	✓	✓	✗
36.	System Voltage THD	✓	✓	✓
37.	Voltage L1 THD	✓	✓	✗
38.	Voltage L2 THD	✓	✓	✗
39.	Voltage L3 THD	✓	✓	✗
40.	System Current	✓	✓	✓
41.	Current L1	✓	✓	✗
42.	Current L2	✓	✓	✗
43.	Current L3	✓	✓	✗
44.	System Current THD	✓	✓	✓
45.	Current L1 THD	✓	✓	✗
46.	Current L2 THD	✓	✓	✗
47.	Current L3 THD	✓	✓	✗
48.	Frequency	✓	✓	✓
49.	RPM	✓	✓	✓
50.	Phase Reversal Indication	✓	✓	✗
51.	Old Import Active Energy (kWh)	✓	✓	✓
52.	Old Export Active Energy (kWh)	✓	✓	✓
53.	Old Inductive Reactive Energy (kVARh)	✓	✓	✓

✓ : Available ✗ : Not Available

Measured Parameter System wise

Sr No	Displayed Parameters	3 Phase 4Wire	3Phase 3Wire	1PH 2W
54.	Old Capacitive Reactive Energy (kVARh)	✓	✓	✓
55.	Old Apparent Energy (Vah)	✓	✓	✓
56.	Old Run Hour	✓	✓	✓
57.	Old On Hour	✓	✓	✓
58.	Old Number of Interruptions	✓	✓	✓

✓ : Available ✗ : Not Available

Measured Parameter Model wise

Sr. No	Parameters	Alpha 40	
		On Display	On Modbus
1.	Import Active Energy (kWh)	✓	✓
2.	Export Active Energy (kWh)	✓	✓
3.	Inductive Reactive Energy (kVARh)	✓	✓
4.	Capacitive Reactive Energy (kVARh)	✓	✓
5.	Apparent Energy (Vah)	✓	✓
6.	System Active Power (kW)	✓	✓
7.	Active Power L1 (kW)	✓	✓
8.	Active Power L2 (kW)	✓	✓
9.	Active Power L3 (kW)	✓	✓
10.	System Re-active Power (kVAR)	✓	✓
11.	Re-active Power L1 (kVAR)	✓	✓
12.	Re-active Power L2 (kVAR)	✓	✓
13.	Re-active Power L3 (kVAR)	✓	✓
14.	System Apparent Power (kVA)	✓	✓
15.	Apparent Power L1 (kVA)	✓	✓
16.	Apparent Power L2 (kVA)	✓	✓
17.	Apparent Power L3 (kVA)	✓	✓
18.	System Power Factor	✓	✓
19.	Power Factor L1	✓	✓
20.	Power Factor L2	✓	✓
21.	Power Factor L3	✓	✓
22.	Current Demand	✓	✓
23.	kVA Demand	✓	✓
24.	Import kW Demand	✓	✓
25.	Export kW Demand	✓	✓
26.	Run Hour	✓	✓
27.	On Hour	✓	✓
28.	Number of Interruptions	✓	✓
29.	System Voltage	✓	✓
30.	Voltage L1	✓	✓
31.	Voltage L2	✓	✓
32.	Voltage L3	✓	✓
33.	Voltage L12	✓	✓
34.	Voltage L23	✓	✓
35.	Voltage L31	✓	✓
36.	System Voltage THD	✓	✓
37.	Voltage L1 THD	✓	✓
38.	Voltage L2 THD	✓	✓
39.	Voltage L3 THD	✓	✓
40.	System Current	✓	✓
41.	Current L1	✓	✓
42.	Current L2	✓	✓

✓ : Available ✗ : Not Available

Sr. No	Parameters	Alpha 40	
		On Display	On Modbus
43.	Current L3	✗	✓
44.	System Current THD	✗	✗
45.	Current L1 THD	✗	✗
46.	Current L2 THD	✗	✗
47.	Current L3 THD	✗	✗
48.	Frequency	✗	✓
49.	RPM	✗	✓
50.	Phase Reversal Indication	✓	✗
51.	Old Import Active Energy (kWh)	✗	✓
52.	Old Export Active Energy (kWh)	✗	✓
53.	Old Inductive Reactive Energy (kVARh)	✗	✓
54.	Old Capacitive Reactive Energy (kVARh)	✗	✓
55.	Old Apparent Energy (Vah)	✗	✓
56.	Old Run Hour	✗	✓
57.	Old On Hour	✗	✓
58.	Old Number of Interruptions	✗	✓

Ordering Information

Product Code	AP40-	X	X	X	X	X	X	X	000000
	Alpha 40	4							
System Type	3PH 3W/4W		3						
	1 Phase		1						
Input Voltage	63.5VL-N			1					
	133VL-N			2					
	230VL-N			3					
	239.6VL-N			4					
	254VL-N			5					
	110VL-L			6					
	230VL-L			7					
	415VL-L			8					
	440VL-L			9					
Input Current	1/5A				5				
Power Supply	60 - 300V AC/DC					U			
RS 485	With RS 485						R		
	MODBUS Option not used						Z		
Pulse Output	Pulse output							P	
	Pulse O/P not used							Z	



sifam tinsley
PRECISION INSTRUMENTATION

Sifam Tinsley Instrumentation Inc.
3105, Creekside Village Drive,
Suite No. 801, Kennesaw,
Georgia 30144 (USA)
E-mail Id : psk@sifamtinsley.com
Web : www.sifamtinsley.com
Contact No. : +1 404 736 4903

Sifam Tinsley Instrumentation Ltd
Unit 1 Warner Drive,
Springwood Industrial Estate
Braintree, Essex, UK, CM72YW
E-mail: sales@sifamtinsley.com
Web: www.sifamtinsley.com/uk
Contact: +44(0)1803615139