

MATERIALS:
 Nylon □
 -4°F to 176 °F
 (-20°C to 80°C)

PART NUMBER	MALE THREAD A	FEMALE THREAD B	WRENCHING FLATS W	THREAD LENGTH T	HEIGHT H
AG-1112-BK	PG 11	1/2" NPT	.94 (24)	.27 (7)	.83 (21)
AG-1312-BK	PG 13	1/2" NPT	.94 (24)	.35 (9)	.91 (23)

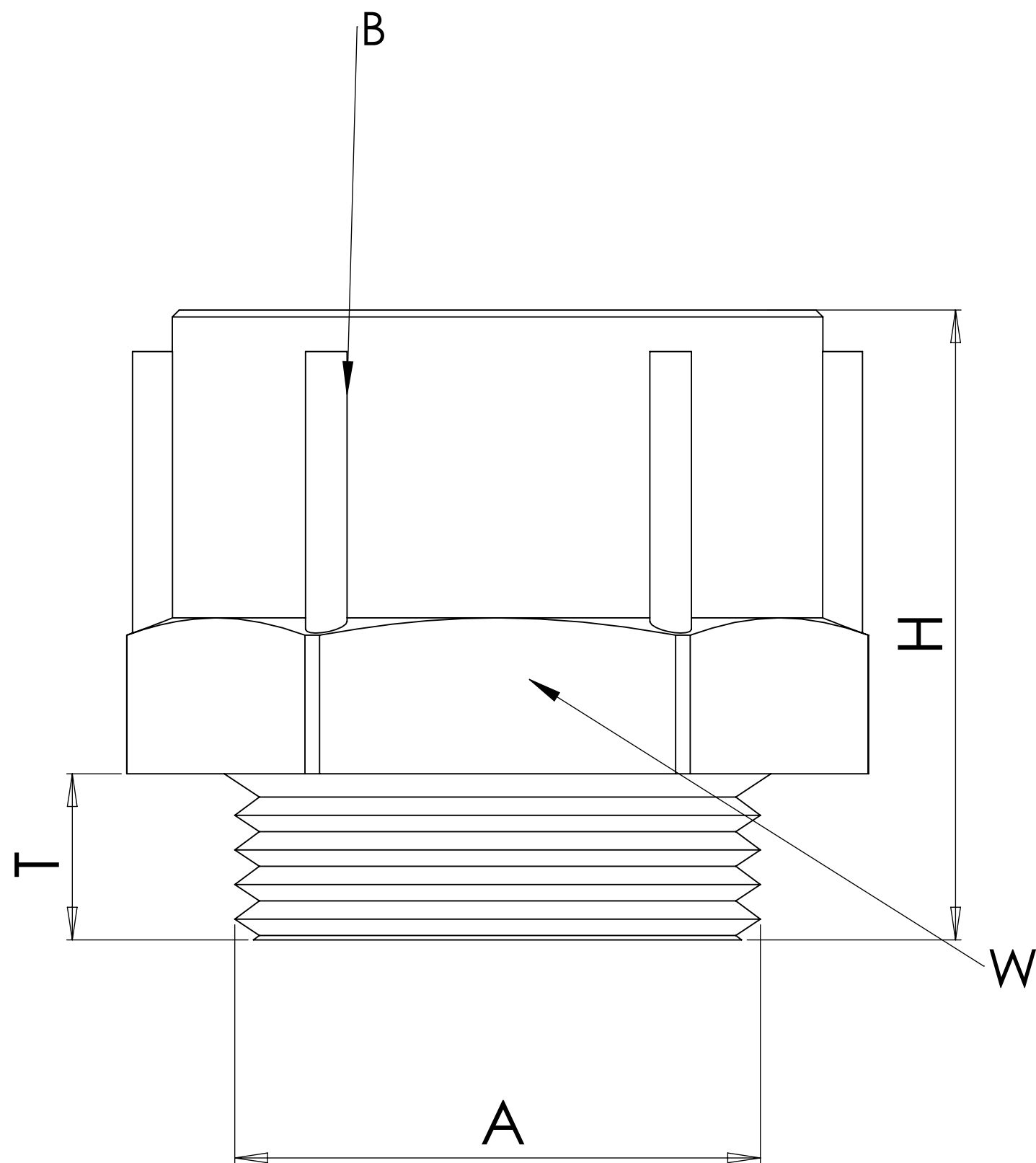

NOTES:

- 1) GENERAL DIMENSIONS DRAWINGS.
- 2) DIMENSIONS [] ARE IN MILLIMETER.
- 3) DIMENSIONS NOTED ARE FOR REFERENCE ONLY.

Third angle projection

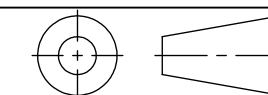

14853 E HINDSDALE AVE, SUITE D
 CENTENNIAL, CO 80112-4240, USA
 TEL: +1-303-699-1135
 TOLL FREE: +1-800-456-9012
 E MAIL: info@sealconusa.com,
 WEBSITE: www.sealconusa.com

