

Ultra-small, Low-cost, Push-operated Switches

- All-in-one design means fewer parts are required. This product delivers high reliability at a low cost.
- Uses long-lasting resin springs to achieve a long mechanical durability expectancy of 30,000 operations.
- Models with stoppers for restricting the setting range are available.
- The series includes a complete range of pen-push models that prevent accidental operation.

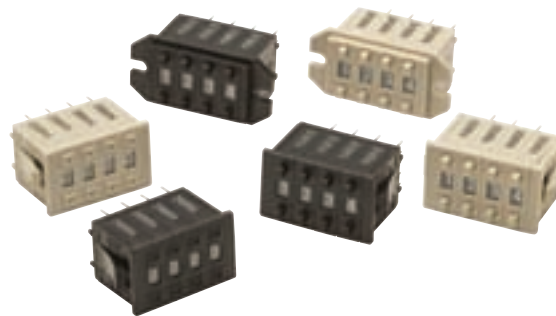

Ordering Information

Switches (Single Switch Units)

Model	A7D				A7DP	
	Screw mounting (back mounting)		Snap-in (front mounting)		Snap-in (front mounting)	
Classification (See note 1.)						
Output code	PCB terminals					
Terminals						
Color	Light gray	Black	Light gray	Black	Light gray	Black
06 (binary coded decimal)	A7D-106	A7D-106-1	A7D-206	A7D-206-1	A7DP-206	A7DP-206-1

Note: 1. The classification diagrams show 4 Switch Units combined with End Caps to create 4-digit displays.

2. The model numbers given above are for 1 Switch Unit.

3. Models with stoppers are also available. Add "-S□□" after the "106" or "206" in the model number and specify the display range in the □□. For example, to specify the range 0 to 6, add "-S06" to the model number (e.g., A7D-106-S06-1).

4. Models with +, - displays are also available. Add "-PM" after the "106" or "206" in the model number (e.g., A7D-106-PM or A7D-106-PM-1).

Accessories (Order Separately)

Use accessories, such as End Caps and Spacers, with the Switch Units.

Classification	Screw mounting (back mounting)		Snap-in (front mounting)	
	Light gray	Black	Light gray	Black
Accessory				
Color				
End Caps (1 pair)	A7D-1M *	A7D-1M-1 *	A7D-2M *	A7D-2M-1 *
Spacer	A7D-1P□ (See note.)	A7D-1P□-1 (See note.)	A7D-2P□ (See note.)	A7D-2P□-1 (See note.)

Note: The □ in the Spacer model number stands for a letter in the range A to U. (Refer to the table in the following explanation about Spacers.)

* The minimum order is for 10 End Caps.

End Caps

End Caps are used on the Switch Units at each end and allow all the Switch Units to be securely mounted to a panel. They come in pairs, one for the left and one for the right.

Spacers

- Spacers are used for creating extra space or gaps between the Switch Units and have the same dimensions as the Switch Units themselves.
- There are also Spacers with engraved characters or symbols that can be used for indicating units, such as time and length. (Refer to the following table.) Consult your OMRON representative for details.

Symbol	A	B	C	D	E	F	G
Stamp	No designation	SEC	MIN	H	g	kg	mm

Symbol	H	J	K	L	Q	T	U
Stamp	cm	m	°C	PCS	x 10 SEC	0	•

Specifications

Switching capacity (resistive load)		5 to 30 VDC 1 mA to 0.1 A
Continuous carry current		100 mA
Contact resistance		200 mΩ max.
Insulation resistance	Between non-connected terminals	10 MΩ min. (at 250 VDC)
	Between terminal and non-current carrying part	100 MΩ min. (at 500 VDC)
Dielectric strength	Between non-connected terminals	250 VAC, 50/60 Hz for 1 min
	Between terminal and non-current carrying part	1,000 VAC, 50/60 Hz for 1 min
Vibration resistance		10 to 55 Hz, 1.5-mm double amplitude
Shock resistance		500 m/s ² min.
Durability	Mechanical	30,000 operations min.
	Electrical	20,000 operations min.
Ambient temperature		Operating: -10°C to 70°C (with no icing) Storage: -20°C to 80°C
Ambient humidity		Operating: 45% to 85%
Max. operating force		3.43 N max.

Dimensions

(Unit: mm)

Switches

A7D-106(-1) PCB Terminals

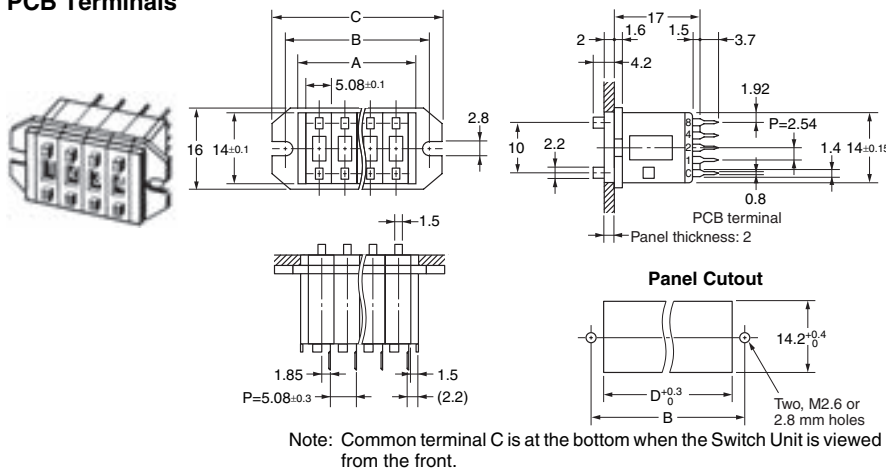

Number of Switches (n)	Size A (n x 5.1 + 3)	Size B (n x 5.1 + 8.3)	Size C (n x 5.1 + 13.3)	Size D
1	8.1	13.4	18.4	8.4
2	13.2	18.5	23.5	13.5
3	18.3	23.6	28.6	18.6
4	23.4	28.7	33.7	23.7
5	28.5	33.8	38.8	28.8
6	33.5	38.9	43.9	33.9
7	38.6	44.0	49.0	39.0
8	43.7	49.1	54.1	44.1
9	48.8	54.2	59.2	49.2
10	53.9	59.3	64.3	54.3

Note: 1. The dimensions above include both End Caps, and will increase 5.08 mm for each Spacer inserted.
2. Unless otherwise specified, a tolerance of ±0.4 mm applies to all dimensions. The tolerance for multiple connection is ±(number of units x 0.4) mm.

A7DP-206(-1) PCB Terminals

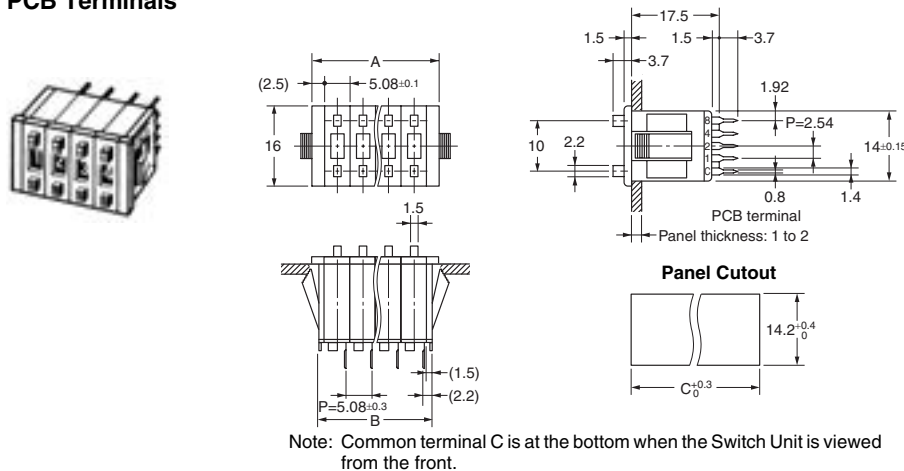

Number of Switches (n)	Size A (n x 5.1 + 5)	Size B (n x 5.1 + 3)	Size C (n x 5.1 + 3.9)
1	10.1	8.1	9
2	15.2	13.2	14.1
3	20.3	18.3	19.2
4	25.4	23.4	24.3
5	30.5	28.5	29.4
6	35.5	33.5	34.5
7	40.6	38.6	39.6
8	45.7	43.7	44.7
9	50.8	48.8	49.8
10	55.9	53.9	54.9

Note: 1. The dimensions above include both End Caps, and will increase 5.08 mm for each Spacer inserted.
2. Unless otherwise specified, a tolerance of ±0.4 mm applies to all dimensions. The tolerance for multiple connection is ±(number of units x 0.4) mm.

Ordering Procedure

Place orders as shown in the example below, specifying the model and number.



1. A7D-2M (End Caps): 1 pair
2. A7D-206-S□□ (Switch Unit with stopper): 1 piece
3. A7D-206 (Switch Unit): 1 piece
4. A7D-2P□ (Spacer): 1 piece
5. A7D-206 (Switch Unit): 2 pieces

Note: Standard products, such as the Switch Units and End Caps, are not factory-assembled for shipment. Contact your OMRON representative for details on ordering factory-assembled sets.

Safety Precautions

Refer to *Safety Precautions for All Thumbwheel Switches*.

Precautions for Correct Use

Handling

- The molded components of the Switch use polyacetal resin and PBT resin. It is recommended that alcohol is used to wipe off dirt and smudges from the molded components. Take care to prevent the alcohol from getting inside.
- Do not use thinner or other solutions which might damage the resin.
- Terminals can withstand a force of 4.9 N for 10 seconds or more (the mating strength of the case and seal), and survive bending of 20° without breaking after returning to original position. Do not use excessive force or apply repetitive external force, however, when handling terminals. In particular, take care to avoid dropping them as the terminals might bend or break.



- The setting buttons can withstand 19.6 N for 1 minute, but do not push the (+) and (-) buttons at the same time.

Soldering

- Using a Soldering Iron

Use a 30-W soldering iron at a temperature of 350°C for a maximum of 3 seconds, and flush as described above.

Do not apply force to the terminals during soldering and for 3 minutes after soldering is completed. Doing so may result in conduction or operation failure.

Ensure that soldering flux and alcohol do not penetrate into the Switch interior

Setting Numbers

Pen-push Type

Press the setting switch with the tip of a ball-point pen. Do not use pencil point or mechanical pencil point to press the setting switch, otherwise the lead of the pencil or mechanical pencil may be broken and A7DP malfunctions may result due to fragments of the broken lead.



Screw-mounting Models

Tighten mounting screws to a torque between 0.2 to 0.24 N·m, using M2.6 screws. Use plain washers or spring washers together with the screws.