

AC Frame Solenoid



Model 28P

Features:

- Available return spring kit
- AC & DC Applications
- See Model 28P AC
- UL recognized

Electrical:

- Coil Voltages: 24, 120, 240 VAC standard
- Coil Termination: 3/16" QC terminals
- Duty Cycle: 100% Continuous, 25% Intermittent, 10% Intermittent, 1% Pulse
- Coil treatment: Plastic cover
- Insulation Class: Class A Rating - 105° C (221° F)
- Dielectric Strength: 1500V 60 Hz

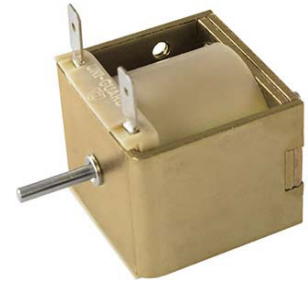

Mechanical:

- Size: 1.13" (L) x 1.08" (W) x 1.19" (H)
- Plunger Diameter: 0.313"
- Plunger Guide Material: Plastic
- Mounting: 2 - #6-32 holes
- Weight: Plunger 0.5 oz, Total 3.5 oz
- Life Expectancy: 1 Million Cycles¹

¹ - Dependent on load conditions

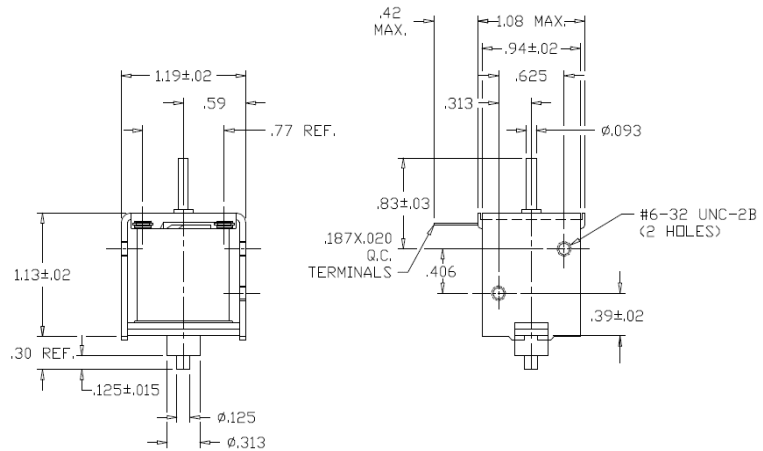

Solenoid shown energized with plunger fully seated in extended position

Standard Part Numbers

Model No.	Part No.	Duty Cycle	Voltage	Resistance ² (Ω)	Power (W)	Current
28P-C-120A	A420-065586-00	Cont.	120VAC	400	8	67 mA
28P-I-120A	A420-065587-00	Inter. 20%	120VAC	220	22	183 mA
28P-C-240A	A420-065588-00	Cont.	240VAC	1600	8	33 mA
28P-I-240A	A420-065589-00	Inter. 20%	240VAC	900	22	92 mA

² - Coil resistance tolerance +/- 5%

Contact us for custom voltages or duty cycles

Available Customization:

- Plunger
- AC Voltage
- Duty Cycle
- Insulation systems up to class H 180° C (356° F)

*** Minimum quantities apply**

Stroke (in.)	Typical Push Force Ounces [N] @ 20°C (68°F) (Distance from fully extended position)				HOLDING FORCE Ounces [N]
	0.050	0.125	0.250	0.375	
Continuous 100%	11 [3.1]	8 [2.2]	6 [1.7]	4 [1.1]	13 [3.6]
Intermittent 20%	18 [5]	14 [3.9]	9 [2.5]	5 [1.4]	15 [4.2]

Continuous Duty = 100% On Time
Intermittent Duty 20% = 20% On Time (4 Minutes On Max Followed By 16 Minutes Off)

Optional Return Spring Kit

A490-367462-00



GUARDIAN-ELECTRIC.COM

1425 Lake Ave - Woodstock IL 60098 - Phone: 800-762-0369
The information is subject to change without notice. © Guardian Electric

