

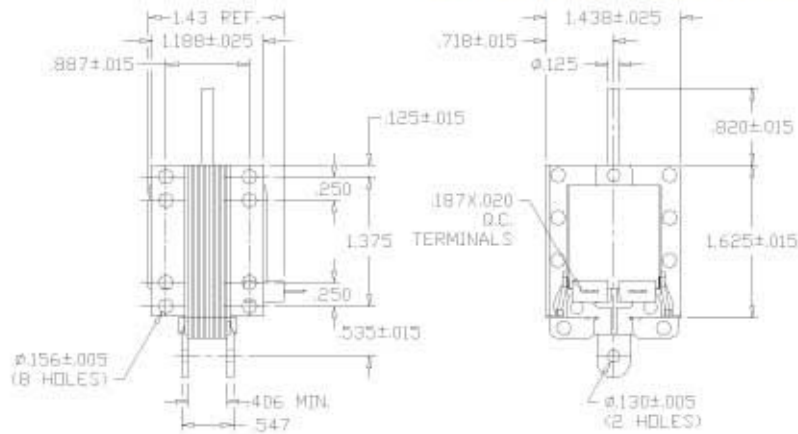

GUARDIAN Electric Manufacturing

ISO 9001 / AS9100 Certified Company
Woodstock, IL 60098 Ph. (815)334-3600 Fax (815)337-0377
Or visit us at our website www.guardian-electric.com

Model 16P Push Laminated AC Frame Solenoid



Solenoid shown energized and fully seated.

Total Weight: 9.5 oz.
Plunger Weight: 2.5 oz.

Model No.	Part No.	Duty Cycle	Volts	Res. (Ω)	Power (VA)	Current, Seated (mA)
16P-I-120A	A420-065147-00	*Intermittent	120	41	70	583
16P-C-120A	A420-065146-00	Continuous	120	85	20	167
16P-I-240A	A420-065149-00	*Intermittent	240	200	70	292
16P-C-240A	A420-065148-00	Continuous	240	350	20	83

When ordering, please refer to Part No., as listed above.
Consult factory for custom configurations.

Stroke (in.)	Push Force (oz.)								Holding Force (oz.)
	0.125	0.250	0.375	0.500	0.625	0.750	1.000		
Continuous Duty	68	43	35	30	23	18	8	70	
*Intermittent Duty	112	80	67	60	50	35	8	130	

UL Recognition

Recognized under the 
Component Recognition Program of
Underwriters Laboratories, Inc.

Continuous Duty

100% 'On' Time

*Intermittent Duty

10% 'On' Time, (150 Seconds 'On' Max.
Followed By 1350 Seconds 'Off' Min.)

RoHS

These parts comply with **RoHS** Directive 2002/95/EC