



**eclipse**<sup>SM</sup>  
YOUR COMPLETE TOOL & ACCESSORY SOURCE

2013 / 2014 CATALOG



## To Our Valued Partners

### This catalog launches the Eclipse branded products!

You may have noticed Eclipse has changed its logo and its marketing efforts. We are launching new programs, products, merchandising, etc. We are in the process of upgrading our website to make it much easier and simpler to find the products and documentation you need. It will be integrated with our new ERP system. We are investing in our future to serve you better.

We will have two catalogs every year going forward

### Eclipse Products and Pro'sKit Products



Be on the lookout for upcoming new products. We will continue to bring you more and more exciting tools and accessories.

And as we continue to grow, be assured that you will continue to receive the personal level of service you have come to expect from Eclipse Tools. Please let us know if there are things we can do to help drive your sales and as always thank you for your continued business and partnership.

Best regards,

Roger Scott  
President, Eclipse Tools



2

1/4 Inch Hex High Quality Bits



8

Cable Ties



11

Splitters



12

(F, RCA & BNC Type) Compression Style Connectors



14

(F Type Coax) Crimp-On, Twist-On, Push-On Connectors



16

Wire Ferrules



22

Multi-Purpose Rivet Kit



24

(F, RCA & BNC Type) Crimpers



26

Strippers and Cutters



30

Punch Down Tools and Tool Kits



32

Tool Bundles



36

Terminals



40

Heat Shrink Tubing



# 1/4 Inch Hex High Quality Bits

**High quality** bits at an economical price

**Made from S-2 tool steel** with a  
Hardness of HRC 59°~61°

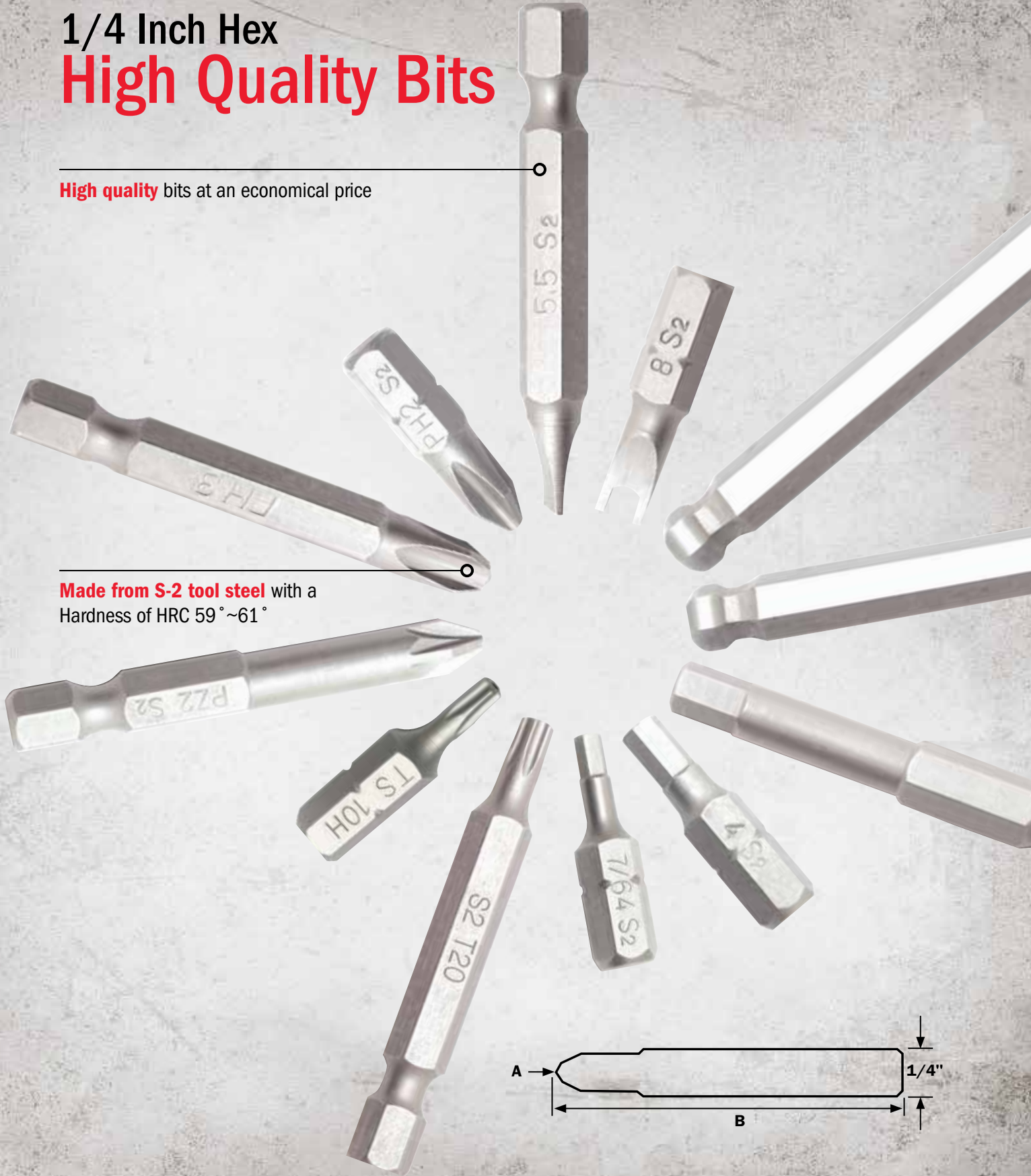





## Slotted Bits

1/4" Hex drive insert bits



PART NO.	A	B
<b>SL12X1-15/16</b>	1-2	1-15/16"
<b>SL23X1-15/16</b>	2-3	1-15/16"
<b>SL34X1-15/16</b>	3-4	1-15/16"
<b>SL45X1-15/16</b>	4-5	1-15/16"
<b>SL56X1-15/16</b>	5-6	1-15/16"
<b>SL68X1-15/16</b>	6-8	1-15/16"
<b>SL810X1-15/16</b>	8-10	1-15/16"
<b>SL1012X1-15/16</b>	10-12	1-15/16"
<b>SL1214X1-15/16</b>	12-14	1-15/16"



## Phillips Bits

1/4" Hex drive insert bits



PART NO.	A	B
<b>PH0X1</b>	#0	1"
<b>PH1X1</b>	#1	1"
<b>PH2X1</b>	#2	1"
<b>PH3X1</b>	#3	1"



PART NO.	A	B
<b>PH0X1-15/16</b>	#0	1-15/16"
<b>PH1X1-15/16</b>	#1	1-15/16"
<b>PH2X1-15/16</b>	#2	1-15/16"
<b>PH3X1-15/16</b>	#3	1-15/16"



## Pozidrive Bits

1/4" Hex drive insert bits



PART NO.	A	B
<b>PZ0X1-15/16</b>	0	1-15/16"
<b>PZ1X1-15/16</b>	1	1-15/16"
<b>PZ2X1-15/16</b>	2	1-15/16"
<b>PZ3X1-15/16</b>	3	1-15/16"
<b>PZ4X1-15/16</b>	4	1-15/16"



Now Packaged for Retail



## Star-Tip Bits

1/4" Hex drive insert bits



PART NO.	A	B
<b>T5X1</b>	T-5	1"
<b>T6X1</b>	T-6	1"
<b>T7X1</b>	T-7	1"
<b>T8X1</b>	T-8	1"
<b>T9X1</b>	T-9	1"
<b>T10X1</b>	T-10	1"
<b>T15X1</b>	T-15	1"
<b>T20X1</b>	T-20	1"
<b>T25X1</b>	T-25	1"
<b>T27X1</b>	T-27	1"
<b>T30X1</b>	T-30	1"



PART NO.	A	B
<b>T5X1-15/16</b>	T-5	1-15/16"
<b>T6X1-15/16</b>	T-6	1-15/16"
<b>T7X1-15/16</b>	T-7	1-15/16"
<b>T8X1-15/16</b>	T-8	1-15/16"
<b>T9X1-15/16</b>	T-9	1-15/16"
<b>T10X1-15/16</b>	T-10	1-15/16"
<b>T15X1-15/16</b>	T-15	1-15/16"
<b>T20X1-15/16</b>	T-20	1-15/16"
<b>T25X1-15/16</b>	T-25	1-15/16"
<b>T27X1-15/16</b>	T-27	1-15/16"
<b>T30X1-15/16</b>	T-30	1-15/16"



## Tamper Resistant Star-Tip Bits

1/4" Star-Tip drive insert bits: tamper resistant



PART NO.	A	B
<b>T7HX1</b>	T-7H	1"
<b>T8HX1</b>	T-8H	1"
<b>T9HX1</b>	T-9H	1"
<b>T10HX1</b>	T-10H	1"
<b>T15HX1</b>	T-15H	1"
<b>T20HX1</b>	T-20H	1"
<b>T25HX1</b>	T-25H	1"
<b>T27HX1</b>	T-27H	1"
<b>T30HX1</b>	T-30H	1"



PART NO.	A	B
<b>T7HX1-15/16</b>	T-7H	1-15/16"
<b>T8HX1-15/16</b>	T-8H	1-15/16"
<b>T9HX1-15/16</b>	T-9H	1-15/16"
<b>T10HX1-15/16</b>	T-10H	1-15/16"
<b>T15HX1-15/16</b>	T-15H	1-15/16"
<b>T20HX1-15/16</b>	T-20H	1-15/16"
<b>T27HX1-15/16</b>	T-27H	1-15/16"
<b>T30HX1-15/16</b>	T-30H	1-15/16"



## Special Penta-lobe Security Star Tip

1/4" Hex drive insert bits



PART NO.	A	B
<b>TS10HX1</b>	TS10H	1"
<b>TS15HX1</b>	TS15H	1"
<b>TS20HX1</b>	TS20H	1"



## Hex Head Bits

1/4" Hex drive insert bits



METRIC

PART NO.	A	B
<b>HX1.5X1</b>	1.5mm	1"
<b>HX2X1</b>	2mm	1"
<b>HX2.5X1</b>	2.5mm	1"
<b>HX3X1</b>	3mm	1"
<b>HX4X1</b>	4mm	1"
<b>HX5X1</b>	5mm	1"
<b>HX6X1</b>	6mm	1"
<b>HX7X1</b>	7mm	1"



## Hex Head Bits

1/4" Hex drive insert bits



S.A.E.

PART NO.	A	B
<b>HX1/16X1</b>	1/16"	1"
<b>HX5/64X1</b>	5/64"	1"
<b>HX3/32X1</b>	3/32"	1"
<b>HX7/64X1</b>	7/64"	1"
<b>HX1/8X1</b>	1/8"	1"
<b>HX9/64X1</b>	9/64"	1"
<b>HX5/32X1</b>	5/32"	1"
<b>HX3/16X1</b>	3/16"	1"
<b>HX7/32X1</b>	7/32"	1"
<b>HX1/4X1</b>	1/4"	1"

S.A.E.



PART NO.	A	B
<b>HX1/16X1-15/16</b>	1/16"	1-15/16"
<b>HX5/64X1-15/16</b>	5/64"	1-15/16"
<b>HX3/32X1-15/16</b>	3/32"	1-15/16"
<b>HX7/64X1-15/16</b>	7/64"	1-15/16"
<b>HX1/8X1-15/16</b>	1/8"	1-15/16"
<b>HX9/64X1-15/16</b>	9/64"	1-15/16"
<b>HX5/32X1-15/16</b>	5/32"	1-15/16"
<b>HX3/16X1-15/16</b>	3/16"	1-15/16"
<b>HX7/32X1-15/16</b>	7/32"	1-15/16"
<b>HX9/32X1-15/16</b>	9/32"	1-15/16"
<b>HX1/1/4X1-15/16</b>	1/4"	1-15/16"



## Ball Hex Head Bits

1/4" Hex drive insert bits



S.A.E.

PART NO.	A	B
<b>BHX5/64X3-1/2</b>	5/64"	3-1/2"
<b>BHX3/32X3-1/2</b>	3/32"	3-1/2"
<b>BHX7/64X3-1/2</b>	7/64"	3-1/2"
<b>BHX1/8X3-1/2</b>	1/8"	3-1/2"
<b>BHX9/64X3-1/2</b>	9/64"	3-1/2"
<b>BHX5/32X3-1/2</b>	5/32"	3-1/2"
<b>BHX3/16X3-1/2</b>	3/16"	3-1/2"
<b>BHX7/32X3-1/2</b>	7/32"	3-1/2"
<b>BHX1/4X3-1/2</b>	1/4"	3-1/2"



METRIC

PART NO.	A	B
<b>BHX2X3-1/2</b>	2mm	3-1/2"
<b>BHX2.5X3-1/2</b>	2.5mm	3-1/2"
<b>BHX3X3-1/2</b>	3mm	3-1/2"
<b>BHX4X3-1/2</b>	4mm	3-1/2"
<b>BHX5X3-1/2</b>	5mm	3-1/2"
<b>BHX6X3-1/2</b>	6mm	3-1/2"

## Assortment Packs

More assortment packs available!

<b>902-390</b>	4 PC	Robertson, S1, 2, 3, 4, 1"
<b>902-391</b>	4 PC	Robertson, S1, 2, 3, 4, 1-15/16"
<b>902-392</b>	8 PC	4 PC Robertson, S1, 2, 3, 4, 1"; 4 PC Robertson, S1, 2, 3, 4, 1-15/16"
<b>902-393</b>	5 PC	Spanner Security Bits 4, 6, 8, 10, 12



## Spanner Security Bits

1/4" Hex drive insert bits



PART NO.	A	B
<b>SSP4X1</b>	#4	1"
<b>SSP6X1</b>	#6	1"
<b>SSP8X1</b>	#8	1"
<b>SSP10X1</b>	#10	1"
<b>SSP12X1</b>	#12	1"

## Robertson Bits

1/4" Hex drive insert bits



PART NO.	A	B
<b>S1X1</b>	2.5mm	1"
<b>S2X1</b>	3mm	1"
<b>S3X1</b>	3.5mm	1"
<b>S4X1</b>	4mm	1"



PART NO.	A	B
<b>S1X1-15/16</b>	2.5mm	1-15/16"
<b>S2X1-15/16</b>	3mm	1-15/16"
<b>S3X1-15/16</b>	3.5mm	1-15/16"
<b>S4X1-15/16</b>	4mm	1-15/16"



# For Distributors/Retailers

## Power Bits with Spinner Rack

- Quality power bits that customers will want to have on hand
- Excellent price point and variety encourages multiple purchases
- Eye catching packaging

### Extra BONUS!

**FREE Spinner Rack and Header Card** with first complete assortment pack order!

Rotating Display 21" H x 12" Diameter



PART NO. BITASST1:

Display Contains ¼" Hex Assortment

3 EACH:

<b>902-373</b>	4 PC	Flat Blade, 1-15/16": 1-2, 3-4, 5-6, 8-10 mm
<b>902-374</b>	4 PC	StarTip 1": T5, T10, T20, T30
<b>902-375</b>	4 PC	StarTip 1-15/16": T5, T10, T20, T30
<b>902-376</b>	4 PC	TamperProof StarTip 1": T7H, T10H, T20H, T30H
<b>902-377</b>	4 PC	TamperProof StarTip: T10H, T15H, T20H, T30H
<b>902-379</b>	11 PC	Jumbo StarTip 1-15/16": T5, T6, T7, T8, T9, T10, T15, T20, T25, T27, T30
<b>902-380</b>	4 PC	Spanner Security Bits 4, 6, 8, 10
<b>902-381</b>	8 PC	Pozi-Drive 1-15/16": 0, 1, 2, 3, 4 & TamperProof Penta-lobe StarTip

6 EACH:

<b>902-372</b>	4 PC	Phillips 1": 0, 1, 2, 3
<b>902-378</b>	12 PC	Jumbo Pack 1-15/16": Phillips 0, 1, 2, 3, Flat Blade 1-2, 3-4, 6-8, 10-12 mm, StarTip T10, T20, T25, T30



**BITASST1**

Reorder complete rack refills.  
Use part no. **BITASST2** or  
individually as needed.



# Cable Ties

HOOK AND LOOP

For use in binding cable bundles and patch cables. **Made of nylon/polypropylene**

**Will not affect the transmittance performance** No pinching caused by over tightening

900-098 SERIES

**Reusable**, the back-to-back design provides instant installation without using tools

NYLON

902-012 THRU 025

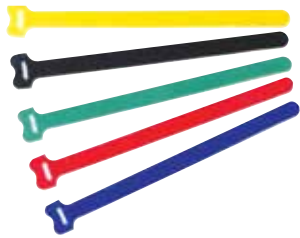

## Hook and Loop Cable Ties

Packs of 25

DESCRIPTION	PART NO.	COLOR	QTY	PKG
8" Hook and Loop Cable Ties	<b>900-098-BK</b>	Black	25	Poly bag with header
	<b>900-098-BU</b>	Blue	25	Poly bag with header
	<b>900-098-GN</b>	Green	25	Poly bag with header
	<b>900-098-OR</b>	Orange	25	Poly bag with header
	<b>900-098-RD</b>	Red	25	Poly bag with header
	<b>900-098-WH</b>	White	25	Poly bag with header
	<b>900-098-YL</b>	Yellow	25	Poly bag with header

## Hook and Loop Cable Tie Assortment

Packs of 15

DESCRIPTION	PART NO.	COLOR	QTY	PKG
Colors: Black, Blue, Green, Red & Yellow	<b>900-098-AST</b>	Assorted	15	Poly bag with header

## Nylon Cable Ties

Packs of 100

DESCRIPTION	PART NO.	COLOR	QTY	PKG
Nylon Cable Ties 4" x 3/32"	<b>902-012</b>	Neutral	100	Poly bag with header
	<b>902-019</b>	Black	100	Poly bag with header
Nylon Cable Ties 7-7/8" x 3/32"	<b>902-015</b>	Neutral	100	Poly bag with header
	<b>902-022</b>	Black	100	Poly bag with header
Nylon Cable Ties 5-1/2" x 9/64"	<b>902-013</b>	Neutral	100	Poly bag with header
	<b>902-020</b>	Black	100	Poly bag with header
Nylon Cable Ties 7-7/8" x 9/64"	<b>902-016</b>	Neutral	100	Poly bag with header
	<b>902-023</b>	Black	100	Poly bag with header
Nylon Cable Ties 7-1/2" x 3/16"	<b>902-014</b>	Neutral	100	Poly bag with header
	<b>902-021</b>	Black	100	Poly bag with header
Nylon Cable Ties 11-3/4" x 3/16"	<b>902-017</b>	Neutral	100	Poly bag with header
	<b>902-024</b>	Black	100	Poly bag with header
Nylon Cable Ties 14-1/2" x 3/32"	<b>902-018</b>	Neutral	100	Poly bag with header
	<b>902-025</b>	Black	100	Poly bag with header





# Hook and Loop Cable Tie Material

Bulk Roll, 50'

DESCRIPTION	WIDTH	PART NO.	COLOR	PKG
Hook and Loop Cable Tie Material (Bulk Roll, 50')	3/4" WIDE	902-305	Black	Poly bag with header
		902-386	Red	Poly bag with header
		902-387	Blue	Poly bag with header
Hook and Loop Cable Tie Material (Bulk Roll, 50')	1/2" WIDE	902-035	Black	Poly bag with header
		902-388	White	Poly bag with header
		902-389	Blue	Poly bag with header

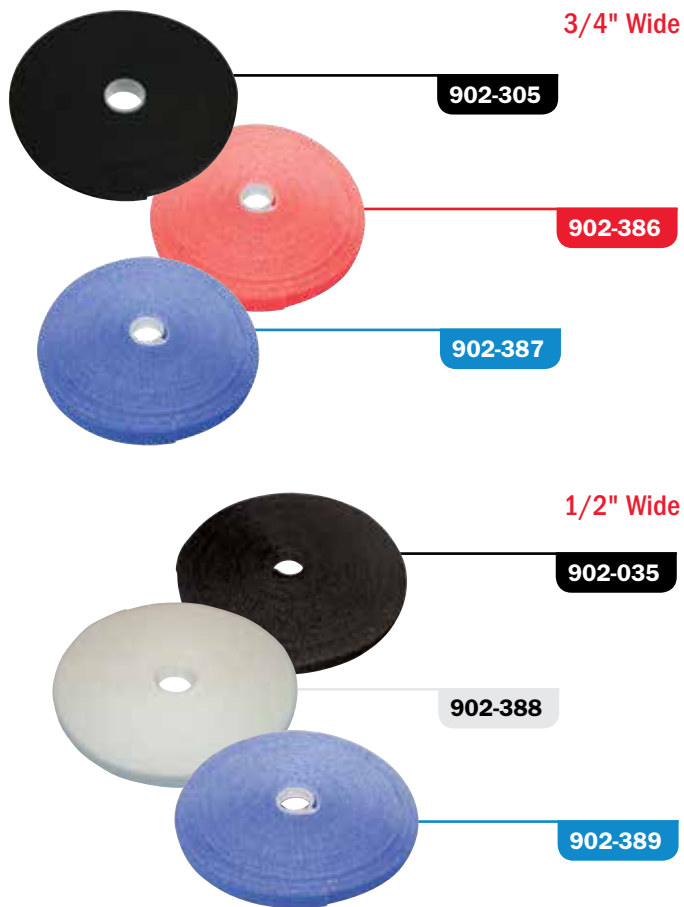



# Assorted Splitters

## Splitters

DESCRIPTION	PART NO.	TYPE
	<b>902-362</b>	2-Way
2-2,300 MHz	<b>902-363</b>	3-Way
	<b>902-364</b>	4-Way
	<b>902-369</b>	2-Way
5-1,000 MHz	<b>902-370</b>	3-Way
	<b>902-371</b>	4-Way

## Diplexer

DESCRIPTION	PART NO.	TYPE
2-2,300 MHz	<b>902-365</b>	2-Way

(Requires the use of a separator)



902-362



902-363



902-364

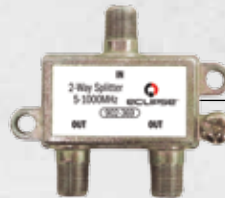

902-369

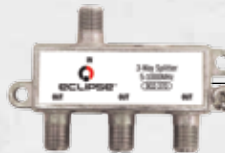

902-370



902-371

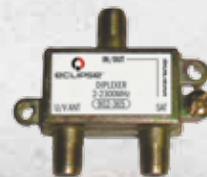

902-365







# (F, RCA & BNC Type) Compression Style Connectors

Provide **high quality termination** and years of trouble free service

**Waterproof**

**360°** shield termination

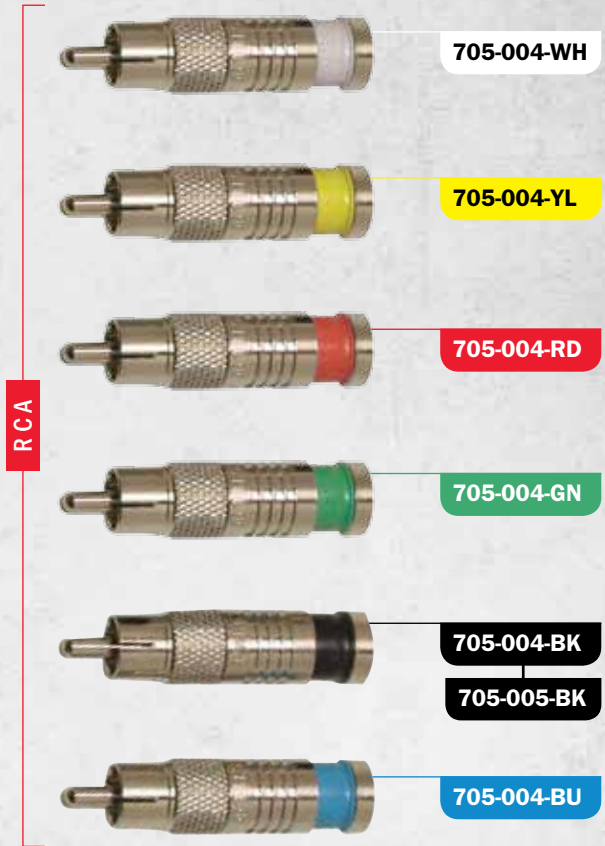
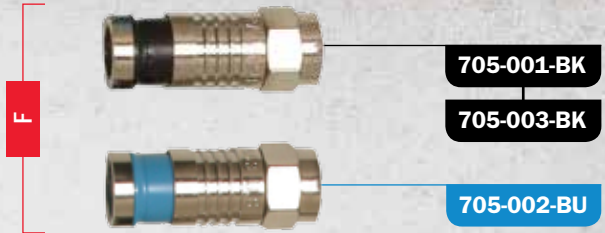



## F Type Connectors

DESCRIPTION	PART NO.	QTY	PKG
F connector for RG6/U (Black)	<b>705-001-BK</b>	100	Jar
	<b>705-001-BK-50</b>	50	Jar
	<b>705-001-BK-20</b>	20	Blisterpack
	<b>705-001-BK-10</b>	10	Blisterpack
F connector for RG6 Quad (Blue)	<b>705-002-BU</b>	100	Jar
	<b>705-002-BU-50</b>	50	Jar
	<b>705-002-BU-20</b>	20	Blisterpack
	<b>705-002-BU-10</b>	10	Blisterpack
F connector for RG59/U (Black)	<b>705-003-BK</b>	100	Jar
	<b>705-003-BK-50</b>	50	Jar
	<b>705-003-BK-20</b>	20	Blisterpack
	<b>705-003-BK-10</b>	10	Blisterpack

## BNC Type Connectors

DESCRIPTION	PART NO.	QTY	PKG
BNC connector for RG6/U (Black)	<b>705-006-BK</b>	100	Jar
	<b>705-006-BK-50</b>	50	Jar
	<b>705-006-BK-20</b>	20	Blisterpack
	<b>705-006-BK-10</b>	10	Blisterpack
BNC connector for RG6 Quad (Blue)	<b>705-007-BU</b>	100	Jar
	<b>705-007-BU-50</b>	50	Jar
	<b>705-007-BU-20</b>	20	Blisterpack
	<b>705-007-BU-10</b>	10	Blisterpack
BNC connector for RG59/U (Black)	<b>705-008-BK</b>	100	Jar
	<b>705-008-BK-50</b>	50	Jar
	<b>705-008-BK-20</b>	20	Blisterpack
	<b>705-008-BK-10</b>	10	Blisterpack

## RCA Type Connectors

DESCRIPTION	PART NO.	QTY	PKG
RCA connector for RG6/U (Green)	<b>705-004-GN</b>	100	Jar
	<b>705-004-GN-50</b>	50	Jar
	<b>705-004-GN-20</b>	20	Blisterpack
	<b>705-004-GN-10</b>	10	Blisterpack
RCA connector RG6/U (Blue)	<b>705-004-BU</b>	100	Jar
	<b>705-004-BU-50</b>	50	Jar
	<b>705-004-BU-20</b>	20	Blisterpack
	<b>705-004-BU-10</b>	10	Blisterpack
RCA connector for RG6/U (Black)	<b>705-004-BK</b>	100	Jar
	<b>705-004-BK-50</b>	50	Jar
	<b>705-004-BK-20</b>	20	Blisterpack
	<b>705-004-BK-10</b>	10	Blisterpack
RCA connector RG6/U (Red)	<b>705-004-RD</b>	100	Jar
	<b>705-004-RD-50</b>	50	Jar
	<b>705-004-RD-20</b>	20	Blisterpack
	<b>705-004-RD-10</b>	10	Blisterpack
RCA connector RG6/U (Yellow)	<b>705-004-YL</b>	100	Jar
	<b>705-004-YL-50</b>	50	Jar
	<b>705-004-YL-20</b>	20	Blisterpack
	<b>705-004-YL-10</b>	10	Blisterpack
RCA connector RG6/U (White)	<b>705-004-WH</b>	100	Jar
	<b>705-004-WH-50</b>	50	Jar
	<b>705-004-WH-20</b>	20	Blisterpack
	<b>705-004-WH-10</b>	10	Blisterpack
RCA connector RG59/U (Black)	<b>705-005-BK</b>	100	Jar
	<b>705-005-BK-50</b>	50	Jar
	<b>705-005-BK-20</b>	20	Blisterpack
	<b>705-005-BK-10</b>	10	Blisterpack



# (F Type Coax) Crimp-On, Twist-On, Push-On Connectors

CRIMP-ON



902-382

902-367

TWIST-ON



902-368

PUSH-ON



902-383



## F Type Coax Crimp-On Connectors

DESCRIPTION	PART NO.	QTY	PKG
Crimp-On RG6Q	<b>902-382-10</b>	10	Blisterpack
	<b>902-382-100</b>	100	Jar
Crimp-On RG6	<b>902-367-10</b>	10	Blisterpack
	<b>902-367-100</b>	100	Jar

## F Type Coax Twist-On Connectors

DESCRIPTION	PART NO.	QTY	PKG
Twist-On RG6	<b>902-368-10</b>	10	Blisterpack
	<b>902-368-100</b>	100	Jar
Twist-On RG59	<b>902-384-10</b>	10	Blisterpack
	<b>902-384-100</b>	100	Jar

## F Type Coax Push-On Connectors

DESCRIPTION	PART NO.	QTY	PKG
Push-On RG6	<b>902-383-10</b>	10	Blisterpack
	<b>902-383-100</b>	100	Jar





# Assorted Wire Ferrules

Provide **high quality termination** and years of trouble free service

All ferrules are **copper with tin plating** (UL\* and RoHS)



\*Applies only to single insulated ferrules, certain sizes only. Contact Eclipse for details.

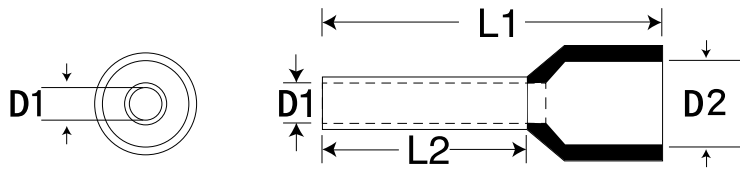

## Insulated Wire Ferrules

AWG	PART NO.	MM <sup>2</sup>	COLOR	L1	L2	D1	D2	QTY
26-28	<b>701-088</b>	0.14	Gray	10	6	0.60	1.5	500
	<b>701-088-100</b>	0.14	Gray	10	6	0.60	1.5	100
24	<b>701-025</b>	0.25	Lt. Blue	10	6	0.85	1.8	500
	<b>701-025-100</b>	0.25	Lt. Blue	10	6	0.85	1.8	100
	<b>701-104</b>	0.25	Yellow	10	6	0.85	1.8	500
	<b>701-104-100</b>	0.25	Yellow	10	6	0.85	1.8	100
	<b>701-007</b>	0.25	Lt. Blue	12	8	0.85	1.8	500
	<b>701-007-100</b>	0.25	Lt. Blue	12	8	0.85	1.8	100
22	<b>701-026</b>	0.34	Turquoise	10	6	0.85	2.0	500
	<b>701-026-100</b>	0.34	Turquoise	10	6	0.85	2.0	100
	<b>701-027</b>	0.34	Turquoise	12	8	0.85	2.0	500
	<b>701-027-100</b>	0.34	Turquoise	12	8	0.85	2.0	100
20	<b>701-008</b>	0.50	Orange	12	6	1.00	2.6	500
	<b>701-008-100</b>	0.50	Orange	12	6	1.00	2.6	100
	<b>701-030</b>	0.50	White	18	12	1.00	2.6	500
	<b>701-030-100</b>	0.50	White	18	12	1.00	2.6	100
	<b>701-013</b>	0.50	White	16	10	1.00	2.6	500
	<b>701-013-100</b>	0.50	White	16	10	1.00	2.6	100
	<b>701-097</b>	0.50	White	14	8	1.00	2.6	500
	<b>701-097-100</b>	0.50	White	14	8	1.00	2.6	100
	<b>701-098</b>	0.50	Blue	14	8	1.30	2.6	500
	<b>701-098-100</b>	0.50	Blue	14	8	1.30	2.6	100
	<b>701-028</b>	0.50	Orange	14	8	1.00	2.6	500
	<b>701-028-100</b>	0.50	Orange	14	8	1.00	2.6	100
	<b>701-131</b>	0.50	Gray	16	10	1.00	2.6	500
	<b>701-131-100</b>	0.50	Gray	16	10	1.00	2.6	100
	<b>701-010</b>	0.50	Orange	16	10	1.00	2.6	500
	<b>701-010-100</b>	0.50	Orange	16	10	1.00	2.6	100

### PACKAGING:

Poly Bag: Quantities of 200 and Up

Blister Pack: Quantities of 100 and Under



## Insulated Wire Ferrules

AWG	PART NO.	MM <sup>2</sup>	COLOR	L1	L2	D1	D2	QTY
18	<b>701-029</b>	0.75	White	12	6	1.00	2.6	500
	<b>701-029-100</b>	0.75	White	12	6	1.00	2.6	100
	<b>701-111</b>	0.75	Gray	14	8	1.20	2.8	500
	<b>701-111-100</b>	0.75	Gray	14	8	1.20	2.8	100
	<b>701-011</b>	0.75	White	14	8	1.20	2.8	500
	<b>701-011-100</b>	0.75	White	14	8	1.20	2.8	100
	<b>701-031</b>	1.00	Yellow	12	6	1.40	3.0	500
	<b>701-031-100</b>	1.00	Yellow	12	6	1.40	3.0	100
	<b>701-132</b>	1.00	Red	12	6	1.40	3.0	500
	<b>701-132-100</b>	1.00	Red	12	6	1.40	3.0	100
	<b>701-014</b>	1.00	Yellow	14	8	1.40	3.0	500
	<b>701-014-100</b>	1.00	Yellow	14	8	1.40	3.0	100
	<b>701-099</b>	1.00	Red	14	8	1.40	3.0	500
	<b>701-099-100</b>	1.00	Red	14	8	1.40	3.0	100
	<b>701-023</b>	1.00	Yellow	16	10	1.40	3.0	500
	<b>701-023-100</b>	1.00	Yellow	16	10	1.40	3.0	100
	<b>701-130</b>	1.00	Red	16	10	1.40	3.0	500
	<b>701-130-100</b>	1.00	Red	16	10	1.40	3.0	100
<b>701-032</b>	1.00	Yellow	18	12	1.40	3.0	500	
<b>701-032-100</b>	1.00	Yellow	18	12	1.40	3.0	100	
<b>701-117</b>	1.00	Red	18	12	1.40	3.0	500	
<b>701-117-100</b>	1.00	Red	18	12	1.40	3.0	100	
16	<b>701-016</b>	1.50	Red	14	8	1.70	3.5	500
	<b>701-016-100</b>	1.50	Red	14	8	1.70	3.5	100
	<b>701-100</b>	1.50	Black	14	8	1.70	3.5	500
	<b>701-100-100</b>	1.50	Black	14	8	1.70	3.5	100
	<b>701-024</b>	1.50	Red	16	10	1.70	3.5	500
	<b>701-024-100</b>	1.50	Red	16	10	1.70	3.5	100
	<b>701-138</b>	1.50	Black	18	12	1.70	3.5	500
	<b>701-138-100</b>	1.50	Black	18	12	1.70	3.5	100
	<b>701-122</b>	1.50	Black	16	10	1.70	3.5	500
	<b>701-122-100</b>	1.50	Black	16	10	1.70	3.5	100
	<b>701-033</b>	1.50	Red	24	18	1.70	3.5	200
	<b>701-033-100</b>	1.50	Red	24	18	1.70	3.5	100
<b>701-101</b>	1.50	Black	24	18	1.70	3.5	500	
<b>701-101-100</b>	1.50	Black	24	18	1.70	3.5	100	

## Wire Ferrule Tools

**300-001** AWG 22-12

**300-144** AWG 10/8/6

**300-077** AWG 6/4/2

**300-079** AWG 28-7



For tools used with wire ferrules, visit [EclipseTools.com](http://EclipseTools.com)



# Insulated Wire Ferrules

AWG	PART NO.	MM <sup>2</sup>	COLOR	L1	L2	D1	D2	QTY
14	<b>701-022</b>	2.50	Blue	15	8	2.20	4.2	500
	<b>701-022-100</b>	2.50	Blue	15	8	2.20	4.2	100
	<b>701-102</b>	2.50	Gray	15	8	2.20	4.2	500
	<b>701-102-100</b>	2.50	Gray	15	8	2.20	4.2	100
	<b>701-034</b>	2.50	Blue	19	12	2.20	4.2	500
	<b>701-034-100</b>	2.50	Blue	19	12	2.20	4.2	100
	<b>701-113</b>	2.50	Gray	19	12	2.20	4.2	500
	<b>701-113-100</b>	2.50	Gray	19	12	2.20	4.2	100
	<b>701-019</b>	2.50	Blue	25	18	2.20	4.2	200
	<b>701-019-100</b>	2.50	Blue	25	18	2.20	4.2	100
12	<b>701-035</b>	4.00	Gray	16	8	2.80	4.8	200
	<b>701-035-100</b>	4.00	Gray	16	8	2.80	4.8	100
	<b>701-036</b>	4.00	Gray	18	10	2.80	4.8	200
	<b>701-036-100</b>	4.00	Gray	18	10	2.80	4.8	100
	<b>701-145</b>	4.00	Orange	20	12	2.80	4.8	200
10	<b>701-145-100</b>	4.00	Orange	20	12	2.80	4.8	100
	<b>701-103</b>	4.00	Orange	18	10	2.80	4.8	200
	<b>701-103-100</b>	4.00	Orange	18	10	2.80	4.8	100
	<b>701-037</b>	4.00	Gray	26	18	2.80	4.8	100
	<b>701-038</b>	6.00	Black	20	12	3.50	6.3	100
8	<b>701-085</b>	6.00	Yellow	20	12	3.50	6.3	100
	<b>701-020</b>	6.00	Black	26	18	3.50	6.3	100
6	<b>701-086</b>	10.00	Red	22	12	4.50	7.6	100
	<b>701-039</b>	10.00	Ivory	22	12	4.50	7.6	100
	<b>701-040</b>	10.00	Ivory	28	18	4.50	7.6	100
4	<b>701-087</b>	16.00	Blue	22	12	5.80	8.8	100
	<b>701-121</b>	16.00	White	22	12	5.80	8.8	100
	<b>701-041</b>	16.00	Green	22	12	5.80	8.8	100
2	<b>701-021</b>	16.00	Green	28	18	5.80	8.8	100
	<b>701-042</b>	25.00	Brown	30	16	7.30	11.2	50
	<b>701-140</b>	25.00	Yellow	30	16	7.30	11.2	50
	<b>701-133</b>	25.00	Black	32	18	7.30	11.2	50
1/0	<b>701-043</b>	25.00	Brown	36	22	7.30	11.2	50
	<b>701-137</b>	35.00	Red	22	16	8.30	12.7	25
	<b>701-044</b>	35.00	Beige	30	16	8.30	12.7	25
	<b>701-045</b>	35.00	Beige	39	25	8.30	12.7	25
	<b>701-046</b>	50.00	Olive	36	20	10.30	15.0	25

**NOTE** Don't see what you want?  
Call **804.561.2610** and we  
may be able to get it for you!

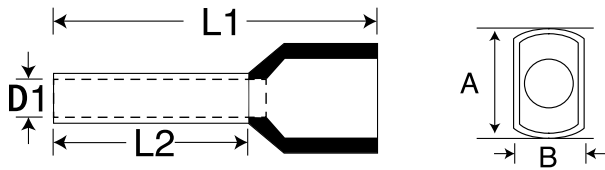

**PACKAGING:**

Poly Bag: Only

## Twin Wire Ferrules (Two Wire)

AWG	PART NO.	MM <sup>2</sup>	COLOR	L1	L2	D1	A/B	QTY
2X20	<b>701-009</b>	0.5	Orange	15	8	1.4	5.0/3.0	500
	<b>701-116</b>	0.5	White	15	8	1.4	5.0/3.0	500
2X18	<b>701-089</b>	0.75	Gray	15	8	1.7	5.5/3.0	500
	<b>701-012</b>	0.75	White	15	8	1.7	5.5/3.0	500
	<b>701-015</b>	1.0	Yellow	16	8	2.0	5.8/3.2	500
	<b>701-090</b>	1.0	Red	15	8	2.0	5.8/3.2	500
2X16	<b>701-139</b>	1.0	Red	20	12	2.0	5.8/3.2	500
	<b>701-017</b>	1.5	Red	16	8	2.2	6.5/3.6	500
	<b>701-143</b>	1.5	Red	20	12	2.2	6.5/3.6	500
	<b>701-091</b>	1.5	Black	16	8	2.2	6.5/3.6	500
2X14	<b>701-120</b>	1.5	Black	20	12	2.2	6.5/3.6	500
	<b>701-018</b>	2.5	Blue	19	10	2.8	8.0/4.5	500
	<b>701-083</b>	2.5	Blue	21	12	2.8	8.0/4.5	200
2X12	<b>701-084</b>	4.0	Gray	22	12	3.5	9.0/5.2	200
2X10	<b>701-112</b>	6.0	Yellow	23	12	4.5	11.4/6.2	100
2X8	<b>701-135</b>	1.0	Red	24	12	5.8	13.4/7.6	100
2X6	<b>701-114</b>	16.0	Blue	29	16	8.3	17.2/9.5	50

**NOTE** Would you like different ferrules in your assortment? **Just ask!** We will do it for you.



## Wire Ferrule Assortment Pack 701-998

**Individual Packaging:**  
Plastic compartment wheel

**Contents:**

- **50 pcs 701-028**  
(Insulated Wire Ferrule, AWG 20, orange)
- **100 pcs 701-011**  
(Insulated Wire Ferrule, AWG 18, white)
- **100 pcs 701-014**  
(Insulated Wire Ferrule, AWG 18, yellow)
- **100 pcs 701-016**  
(Insulated Wire Ferrule, AWG 16, red)
- **50 pcs 701-022**  
(Insulated Wire Ferrule, AWG 14, blue)

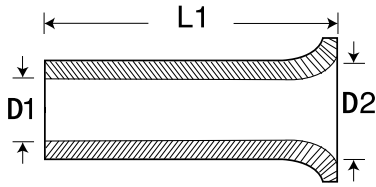

## Uninsulated Wire Ferrules

### PACKAGING:

Poly Bag: Only

AWG	PART NO.	MM <sup>2</sup>	L1	D1	D2	QTY
24	<b>701-001</b>	0.25	5	0.8	1.7	1000
22	<b>701-129</b>	0.34	5	.085	1.8	1000
20	<b>701-047</b>	0.50	6	1.0	2.1	1000
	<b>701-048</b>	0.50	10	1.0	2.1	1000
18	<b>701-002</b>	0.75	6	1.2	2.3	1000
	<b>701-136</b>	0.75	8	1.2	2.3	1000
	<b>701-049</b>	0.75	10	1.2	2.3	1000
	<b>701-050</b>	1.00	6	1.4	2.5	1000
16	<b>701-003</b>	1.00	10	1.4	2.5	1000
	<b>701-051</b>	1.50	7	1.7	2.8	1000
	<b>701-004</b>	1.50	10	1.7	2.8	1000
	<b>701-052</b>	1.50	12	1.7	2.8	1000
14	<b>701-053</b>	1.50	18	1.7	2.8	1000
	<b>701-054</b>	2.50	7	2.2	3.4	1000
	<b>701-005</b>	2.50	10	2.2	3.4	1000
	<b>701-055</b>	2.50	12	2.2	3.4	1000
12	<b>701-056</b>	2.50	18	2.2	3.4	1000
	<b>701-057</b>	4.00	9	2.8	4.0	500
	<b>701-006</b>	4.00	12	2.8	4.0	1000
	<b>701-058</b>	4.00	15	2.8	4.0	500
10	<b>701-059</b>	4.00	18	2.8	4.0	500
	<b>701-060</b>	6.00	10	3.5	4.7	500
	<b>701-061</b>	6.00	12	3.5	4.7	500
	<b>701-062</b>	6.00	15	3.5	4.7	500
8	<b>701-063</b>	6.00	18	3.5	4.7	500
	<b>701-064</b>	10.00	12	4.5	5.8	250
	<b>701-065</b>	10.00	15	4.5	5.8	250
	<b>701-066</b>	10.00	18	4.5	5.8	250
	<b>701-147</b>	10.00	25	4.5	5.8	500

AWG	PART NO.	MM <sup>2</sup>	L1	D1	D2	QTY
6	<b>701-067</b>	16.00	12	5.8	7.5	200
	<b>701-068</b>	16.00	15	5.8	7.5	200
	<b>701-069</b>	16.00	18	5.8	7.5	200
	<b>701-070</b>	16.00	25	5.8	7.5	200
4	<b>701-071</b>	16.00	32	5.8	7.5	200
	<b>701-115</b>	25.00	12	7.3	9.5	100
	<b>701-072</b>	25.00	15	7.3	9.5	200
	<b>701-073</b>	25.00	18	7.3	9.5	200
2	<b>701-074</b>	25.00	25	7.3	9.5	200
	<b>701-075</b>	25.00	32	7.3	9.5	200
	<b>701-076</b>	35.00	18	8.3	11.0	100
	<b>701-077</b>	35.00	25	8.3	11.0	100
1/0	<b>701-078</b>	35.00	30	8.3	11.0	100
	<b>701-079</b>	35.00	32	8.3	11.0	100
	<b>701-080</b>	50.00	18	10.3	13.0	100
	<b>701-081</b>	50.00	22	10.3	13.0	100
2/0	<b>701-082</b>	50.00	32	10.3	13.0	100
	<b>701-142</b>	70.00	25	12.5	15.0	100
3/0	<b>701-125</b>	70.00	32	12.5	15.0	100
4/0	<b>701-126</b>	95.00	32	14.5	17.0	100
300 MCM	<b>701-127</b>	120.00	32	17.2	19.0	100
350 MCM	<b>701-128</b>	150.00	32	19.5	21.0	100
500 MCM	<b>701-146</b>	185.00	32	20.0	23.5	100
	<b>701-148</b>	240.00	40	23.0	25.0	25



# Multi-Purpose Rivet Kit

## RAPTOR RCG<sup>SM</sup> RIVET. CRIMP-IT. GRIP-IT

7 interchangeable die sets

Multi-purpose rivet kit, pop rivet tool, electrical crimper, multi-head pliers

Includes 5 X 25 aluminum blind rivets  
(Do not use steel rivets)



Watch the Raptor RCG in action. Scan for our website video.



## Multi-Purpose Rivet Kit

- Quality Pop Rivet Tool
- Electrical Crimper
- Multi-Head Pliers

A quality and versatile multi-function tool. Perfect for installers and technicians in a variety of fields including cable, network solutions, and electricians.

## Raptor RCG

902-385

### WHAT'S IN THE BOX:

- Raptor Multi-Purpose Rivet Tool with Storage Case
- 1 Blind Pop Rivet Attachment (For Aluminum Rivets 2.4 - 5.0 mm)

- 5 X 25 Aluminum Blind Rivets

DIA	LENGTH	GRIP RANGE
3.2	8.0	3.5-5.5
4.0	8.0	3.5-6.0
4.0	12.0	6.5-9.0
4.8	10.0	3.5-7.0
4.8	14.0	7.0-10.5

- 7 Interchangeable Die Sets

- ◆ 4 Plier Die Sets

- Combination Pliers with Wire Cutter

- Pipe Wrench

- Flat Pliers Serrated

- Flat Pliers Unserrated

- ◆ 3 Crimp Die Sets

- Ferrules 0.5 - 6.0mm

- Coax Connectors RG 58, 59, 62

- Insulated Terminals – AWG 20-10

**RIVET**  
**CRIMP-IT GRIP-IT**





# Assorted Crimpers



902-360

Ratcheting **force-saving** design

**Ergonomically** designed non-slip handle for user comfort



## 300-079 Crimper

- **DESCRIPTION:** Ratcheted, AWG 28-7 wire ferrules
- **APPLICATION:** For crimping all wire ferrules insulated and non-insulated (AWG 28-7). Produces square crimp cross section. Made in Germany.
- **PACKAGING:** Blister Card



## 902-350 Crimper

- **DESCRIPTION:** F-Type Hex Crimper
- **APPLICATION:** For crimping RG6, RG6Q & 2 PC. Hex Crimp connectors. Hex sizes .068/.262/.324/.360
- **PACKAGING:** Blister Card



## 902-348 Crimper

- **DESCRIPTION:** Compression Connector Crimper
- **APPLICATION:** For crimping F, RCA, BNC type compression connectors. Adaptable head for different connector types.
- **PACKAGING:** Blister Card



## 902-360 Crimper

- **DESCRIPTION:** Ratcheted Modular Plug Crimper
- **APPLICATION:** For crimping RJ11, RJ12, RJ45 modular plugs. Cuts and strips silver satin flat telecom cable. Cuts and strips CAT5/6 UTP cable.
- **PACKAGING:** Blister Card





# Assorted Strippers and Cutters



902-344

Built in return spring, **locking latch**

Frame made of stamped, hardened **carbon steel** with curved cutting blade

**Soft** non-slip PVC handle for a comfortable grip



902-349

## 902-345 Universal Cable Stripper

- **DESCRIPTION:** Strip flat wire and round cable with adjusting knob control to meet different cable sizes. Sharp SK-2 blade for easy cutting and stripping. Body made of ABS plastic.
- **APPLICATION:** Strip flat wire including stranded phone wire 2P, 4P, 6P, 8P, 10P, etc.; Intercom/alarm/2-cord speaker wire from 18-22 AWG max and SPT-1 electric wire. Strip round cable including round cable-tough plastic insulations 12-14-16 AWG cable SPT-2 electric wire; assorted solid modular wire UTP/STP data communication wires and network cables; multi-conductor cable insulation O.D. 1/8"-3/8" and automotive heavy-duty wire up to 8 AWG.
- **PACKAGING:** Blister Card



## 902-346 Coaxial Cable Stripper

- **DESCRIPTION:** Strip flat wire and round cable with adjusting bolt control to meet different cable sizes. Sharp SK-2 blade for easy cutting and stripping. Body made of ABS plastic.
- **APPLICATION:** Strip flat wire including stranded phone wire 2P, 4P, 6P, 8P, 10P, etc.; intercom/alarm/2-cord speaker wire from 18-22 AWG max and SPT-1 electric wire. Strip round cable with guides by rotating 1 to 3 times including round cable-tough plastic insulations 12-14-16 AWG cable SPT-2 electric wire; assorted solid modular wire UTP STP data communication wires and network cables; multi-conductor cable insulation O.D. 1/8"-3/8" and automotive heavy-duty wire up to 8 AWG.
- **PACKAGING:** Blister Card



## 902-349 Wire Stripper and Cutter

- **DESCRIPTION:** Light weight spring loaded wire stripper and cutter made specifically for electronics and other precision fields. Processed by CNC machine for accurate size of notches. Safety lock design for convenient storage.
- **APPLICATION:** AWG 30, 28, 26, 24, 22, 20
- **PACKAGING:** Blister Card





## 902-357 Universal Cable Stripper

- **DESCRIPTION:** Strip flat wire and round cable with adjusting knob control to meet different cable sizes with built-in cable cutter function.
- **APPLICATION:** Strips outer jacket of UTP and STP cable and CAT 5/6 round telephone cable; RG-59/6/11/7 coaxial cable and flat telephone cable. Cable cutter function.
- **PACKAGING:** Blister Card



## 902-358 Wire Stripper and Cutter

- **DESCRIPTION:** Made specifically for electronics and other precision fields. Processed by CNC machine for accurate size of notches with safety lock design for convenient storage. Light weight for easy operation.
- **APPLICATION:** AWG 20, 18, 16, 14, 12, 10
- **PACKAGING:** Blister Card



## 902-359 All-in-One Cable TV Tool

- **DESCRIPTION:** All-in-one combination for cutting, stripping and crimping with safety cover. Spring loaded for user convenience. Made of carbon steel with black oxide finish for anti-corrosion.
- **APPLICATION:** For cutting and stripping RG6 coaxial cable and crimping RG6 cable TV "F" connectors
- **PACKAGING:** Blister Card



## 200-014 Self Adjusting Stripper

- **DESCRIPTION:** Completely self-adjusting with built-in scissors action cutter and easy to change replacement blade cartridges.
- **APPLICATION:** AWG 28-10
- **REPLACEMENT:** 900-013: Blade Cartridge
- **PACKAGING:** Blister Card



900-013





## 200-078 Self Adjusting Stripper

- **DESCRIPTION:** Completely self-adjusting with built-in scissors action cutter and easy to change replacement blade cartridges.
- **APPLICATION:** AWG 28-10
- **REPLACEMENT:** 200-078B: Blade
- **PACKAGING:** Blister Card

200-078B



## 902-344 Round Cable Cutter

- **DESCRIPTION:** Rounded blades help keep cable round when cut; Safety lock for easy storage; Built-in return spring and non-slip PVC handles for user comfort; Frame made of stamped, hardened carbon steel with curved cutting blade
- **APPLICATION:** For cutting multi-conductor cable up to 0.5" and stranded wire up to 8AWG
- **PACKAGING:** Blister Card



## 600-006 Battery Operated Cable Cutter

- **DESCRIPTION:** Includes charger and rechargeable 12V battery; impact resistant case; forward and reverse cycles; 2" maximum diameter - 750 MCM
- **APPLICATION:** For use with copper and aluminum cable only - not to be used with steel or ACSR
- **REPLACEMENT:** 200-032: Blade (moving); 200-033 Blade (stationary); 600-010: Spare Battery
- **PACKAGING:** Plastic Case



600-010



# Assorted Punch Down Tools and Tool Kits

902-347

**Wire stripping tool** combines stripping and cutting functions

**Modular crimper** for terminating RJ45 and RJ11/12 network cable.

**Impact punch down tool** with impact function for quick, painless wire terminations.



## 902-352 Non-Impact Punch Down Tool

- **DESCRIPTION:** Mini punch down tool (110/88 blade type) with cut function; fixed blade, not changeable non-impact tool
- **APPLICATION:** Can be used with terminal blocks and keystone jacks
- **PACKAGING:** Blister Card



## 902-341 Non-Impact Punch Down Tool

- **DESCRIPTION:** Impact function. Blade made of 40Cr and hardened and is easy to exchange w/o screwdriver. Self-lock style holder provides quick, easy blade changes and prevents pullout.
- **APPLICATION:** 110/88 reversible blade with cut function on one end
- **PACKAGING:** Blister Card



## 902-347 Network Service Kit

- **DESCRIPTION:** Kit contains three tools and 10pcs RJ-45 connectors. Perfect for making new patch cords or terminating 110/88 jacks and/or patch panels.
- **APPLICATION:** Wire stripping tool combines stripping and cutting functions to correctly prepare network cables without damaging vital conductors. Modular crimpers for terminating RJ45 and RJ11/12 network cable. Impact punch down tool with impact function for quick, painless wire terminations.
- **PACKAGING:** Plastic Case Size: 12.5" x 10.3" x 2.4"



## 902-356 Home Entertainment Tool Kit

- **DESCRIPTION:** Kit includes all of the tools you need to make coax cables including 3 tools and 10pcs RG6 CATV "F" connectors. Set comes with a plastic carrying case and foam insert to hold each tool for carrying and storage convenience.
- **APPLICATION:** Cuts multi-conductor cable up to 0.5" and stranded wire up to 8AWG; crimp cable TV "F" connectors: 0.324" & 0.360" Hex sizes and wire stripping.
- **PACKAGING:** Plastic Case Size: 12.5" x 10.3" x 2.4"





# Assorted Tool Bundles

902-351

Includes **10pcs RJ45, 10pcs RJ 11 connectors**

A **modular crimper** for 4/6/8P modular connector and stripping twisted pair and flat wire

**Strip** flat wire and rounded cables



ECLIPSE

902-351

### DIY Crimp Bundle

For Phone and Computer

RJ-45 x 10pcs  
RJ-11 x 10pcs



902-361

## 902-340 CATV "F" Compression Bundle

- **DESCRIPTION:** Bundle includes round cable cutter, compression connector crimping tool; wire stripping tool and 10pcs F compression connectors
- **APPLICATION:** RG58/59/62/6, F, BNC, RCA Connector
- **PACKAGING:** Clamshell



## 902-351 DIY Crimp Bundle for Phone and Computer

- **DESCRIPTION:** Complete tool bundle along with modular plugs to make RJ45 or RJ11 patch cords for Phone and Computer. It includes crimper, stripper and 10pcs RJ45, 10pcs RJ 11 connectors to make your work smart and easy.
- **APPLICATION:** A wire stripper combines stripping and cutting functions. Stripping flat wire for: stranded phone wire 2P, 4P, 6P, 8P, 10P, etc.; intercom/alarm wire/2-cord speaker wire from 18-22 AWG and SPT-1 electric wire. Stripping round cable for: round cable-tough plastic insulations, 12-14-16 AWG cable SPT-2 electric wire; assorted solid modular wire UTP STP data communication wires and network cables; multi-conductor cable insulation 1/8"-3/8"; automotive heavy-duty wire up to 8 AWG. A Modular Crimper for 4/6/8P modular connector and stripping twisted pair and flat wire.
- **PACKAGING:** Clamshell



## 902-353 Punch Down Tool Bundle

- **DESCRIPTION:** Complete tool bundle to terminate 110 jacks or patch panels. Includes universal stripper for round data cables and 110/88 impact punch down tool to make a professional connection.
- **APPLICATION:** Universal cable stripper for stripping flat wire for stranded phone wire 2P, 4P, 6P, 8P, 10P, etc; intercom/alarm wire/2-cord speaker wire from 18-22 AWG max and SPT-1 electric wires. Stripping round cable for round cable-tough plastic insulations 12-14-16 AWG cable SPT-2 Electric Wires and assorted solid modular wire UTP STP data communication wires, network cables and multi-conductor cable insulation. Impact punch down tool features 110/88 blade with cut function on one end.

**PACKAGING:** Clamshell







## 902-354 Network Tool Bundle

- **DESCRIPTION:** Bundle contains three tools including a Wire Stripping Tool, Modular Plug Crimping Tool, and a 110/88 Impact Punchdown Tool.
- **APPLICATION:** Universal cable stripper for stripping flat wire for stranded phone wire 2P, 4P, 6P, 8P, 10P, etc; intercom/alarm wire/2-cord speaker wire from 18-22 AWG max and SPT-1 electric wires. Stripping round cable for round cable-tough plastic insulations 12-14-16 AWG cable SPT-2 electric wires and assorted solid modular wire UTP STP data communication wires, network cables and multi-conductor cable insulation. Impact punch down tool features 110/88 blade with cut function on one end. Modular crimping tool features application for 4/6/8P modular connector
- **PACKAGING:** Clamshell



## 902-361 Cable TV "F" DIY Bundle

- **DESCRIPTION:** 6pcs "F" type push-on connector. Make new cables for cable TV, cable modems and UHF antennas in a snap. No crimping required.
- **APPLICATION:** Quick and easy installation, push-on connector comes with special knurled nut which offers a superior grip for strong connection
- **PACKAGING:** Blister Card





# 902-400 Eclipse Cable Detect & Connect

All-in-one universal cable tester for computers & networks, video, industrial & medical devices

## FUNCTION:

Tests cables with the following terminations:

- Modular plugs: RJ45, RJ11, RJ12 shielded and unshielded (UTP/STP)
- Coaxial: BNCs and CATV "F"s (BNC-to-F adapter required; not included)
- D-Sub: 9-, 15- and 25-pin
- HD-Sub: 15-pin
- USB: A, B, and mini 5-pin
- 1394 firewire: 4- and 6-pin
- Mini-DIN: 4- and 6-pin
- Centronics: 36-pin printer

## FEATURES AND BENEFITS

- Maps cable pin-outs
- Identifies opens, shorts and cross-connections
- Cable select button to quickly change from one cable type to another
- Automatic scan or manual modes
- Easy to read and understand LED indicators
- Auto-off to conserve battery power
- Rugged case with handle for convenient transport
- Rubber feet to prevent slipping on desk top

## SPECIFICATIONS

Cable Type	Max Cable Length
D-sub	1,000' (305 m)
Phone and data	1,000' (305 m)
USB	1,000' (305 m)
Firewire	1,000' (305 m)
DIN & mini-DIN	1,000' (305 m)
Centronics	1,000' (305 m)
Coax-50 ohm	1,000' (305 m)
Coax-75 ohm	600' (183 m)

## POWER REQUIREMENTS

9VDC Battery (not included)

Output Signal	8VDC@10mA
Auto power-off	30 seconds of non-use
Dimensions	11" H x 6.65" W x 1.60" D
Weight	1.7 lbs.



902-400



Watch **Cable Detect & Connect** in action. Scan now for our website video.



# Assorted Terminals

RING  
TERMINALS



BUTT  
SPLICES



FEMALE  
DISCONNECTS

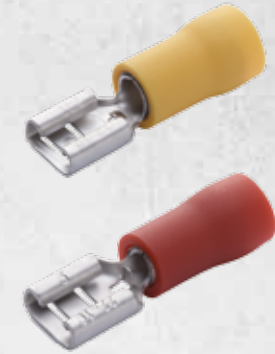

CLOSED END  
CONNECTORS



SPADE  
TERMINALS



## Uninsulated Ring Terminals (Brazed Seam)

AWG	PART NO.	STUD SIZE	DIMENSIONS IN INCHES				
			d1	d2	B	L	t
22-16	<b>902-407-10</b>	#4	.074	.126	.217	.453	.029
	<b>902-406-10</b>	#6	.074	.146	.260	.567	.029
	<b>902-408-10</b>	#8	.074	.169	.260	.567	.029
	<b>902-409-10</b>	1/4"	.074	.252	.457	.846	.029
16-14	<b>902-410-10</b>	#6	.098	.146	.335	.661	.031
	<b>902-411-10</b>	#8	.098	.169	.260	.567	.031
	<b>902-412-10</b>	#10	.098	.209	.335	.661	.031
	<b>902-413-10</b>	1/4"	.098	.252	.472	.835	.031
14-12	<b>902-414-10</b>	#10	.133	.209	.374	.768	.031
12-10	<b>902-415-10</b>	#8	.141	.169	.291	.728	.039
	<b>902-416-10</b>	#10	.141	.209	.291	.728	.039
	<b>902-417-10</b>	1/4"	.141	.252	.472	1.004	.039

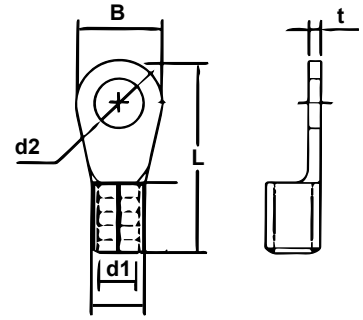

## Insulated Ring Terminals (Vinyl)

AWG	PART NO.	STUD SIZE	DIMENSIONS IN INCHES			
			B	d	L	t
22-16 Red	<b>902-437-10</b>	#6	.217	.146	.689	.030
	<b>902-438-10</b>	#8	.260	.169	.803	.030
	<b>902-439-10</b>	#10	.315	.209	.854	.030
	<b>902-440-10</b>	1/4"	.457	.252	1.087	.030
16-14 Blue	<b>902-441-10</b>	#6	.335	.146	.906	.031
	<b>902-442-10</b>	#8	.335	.169	.906	.031
	<b>902-443-10</b>	#10	.335	.209	.906	.031
	<b>902-444-10</b>	1/4"	.472	.252	1.106	.031
12-10 Yellow	<b>902-445-10</b>	#8	.291	.169	1.051	.039
	<b>902-446-10</b>	#10	.374	.209	1.051	.039
	<b>902-447-10</b>	1/4"	.472	.252	1.287	.039

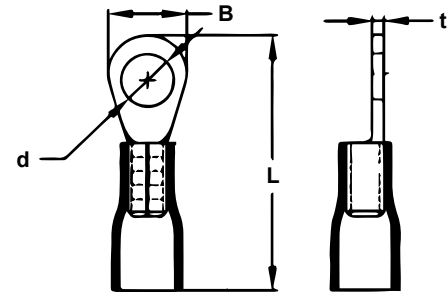



## Closed End Connectors

DIMENSIONS IN INCHES

AWG	PART NO.	D	C	L	t
22-16	<b>902-402-10</b>	.244	.102	.709	.014
16-14	<b>902-403-10</b>	.311	.118	.776	.014
12-10	<b>902-404-10</b>	.413	.157	1.004	.018
8	<b>902-405-10</b>	.472	.209	1.091	.037

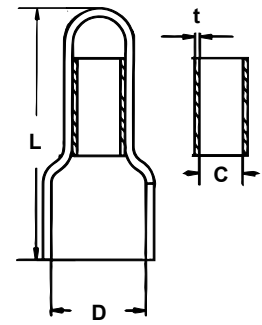

## Butt Splices

DIMENSIONS IN INCHES

AWG	PART NO.	D	d	L	F	t
22-16 Red	<b>902-418-10</b>	.169	.067	.984	.591	.030
16-14 Blue	<b>902-419-10</b>	.177	.094	.984	.591	.031
12-10 Yellow	<b>902-420-10</b>	.256	.141	1.063	.591	.037

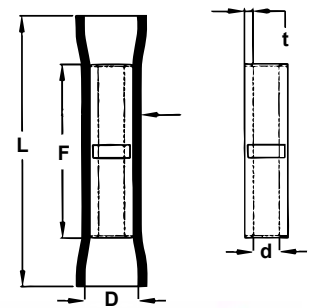

## Female Disconnects (Push-Ons)

DIMENSIONS IN INCHES

AWG	PART NO.	TAB SIZE	D	B	L	t
22-16 Red	<b>902-421-10</b>	.187 X .032	.142	.197	.748	.016
	<b>902-422-10</b>	.205 X .020	.142	.220	.787	.016
16-14 Blue	<b>902-423-10</b>	.187 X .032	.173	.197	.748	.016
	<b>902-424-10</b>	.205 X .020	.173	.22	.787	.016
12-10 Yellow	<b>902-425-10</b>	.187 X .032	.213	.197	.866	.016
	<b>902-426-10</b>	.250 X .032	.213	.264	.984	.016

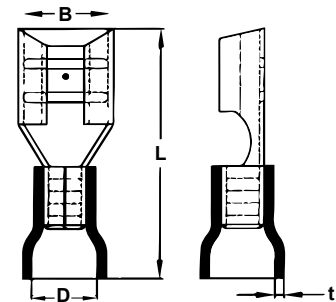



## Spade Terminals

AWG	PART NO.	STUD SIZE	DIMENSIONS IN INCHES			
			B	d	L	t
22-16 Red	<b>902-448-10</b>	#6	.224	.146	.866	.030
	<b>902-449-10</b>	#8	.252	.169	.866	.030
	<b>902-450-10</b>	#10	.315	.209	.866	.030
	<b>902-451-10</b>	1/4"	.037	.252	.906	.030
16-14 Blue	<b>902-452-10</b>	#6	.224	.146	.866	.031
	<b>902-453-10</b>	#8	.252	.169	.866	.031
	<b>902-454-10</b>	#10	.315	.209	.866	.031
	<b>902-455-10</b>	1/4"	.366	.252	.925	.031
12-10 Yellow	<b>902-456-10</b>	#8	.248	.169	1.051	.039
	<b>902-457-10</b>	#10	.354	.209	1.051	.039
	<b>902-458-10</b>	1/4"	.354	.252	1.209	.039

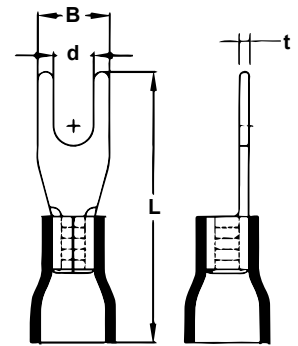

## Locking Spade Terminals

AWG	PART NO.	STUD SIZE	DIMENSIONS IN INCHES			
			B	d	L	t
22-16 Red	<b>902-427-10</b>	#6	.224	.146	.866	.030
	<b>902-428-10</b>	#8	.283	.169	.866	.030
	<b>902-429-10</b>	#10	.315	.209	.906	.030
16-14 Blue	<b>902-430-10</b>	#6	.244	.146	.866	.031
	<b>902-431-10</b>	#8	.283	.169	.866	.031
	<b>902-432-10</b>	#10	.315	.209	.866	.031
12-10 Yellow	<b>902-433-10</b>	#6	.319	.146	1.051	.039
	<b>902-434-10</b>	#8	.323	.169	1.051	.039
	<b>902-435-10</b>	#10	.354	.209	1.051	.039
	<b>902-436-10</b>	1/4"	.472	.252	1.209	.039

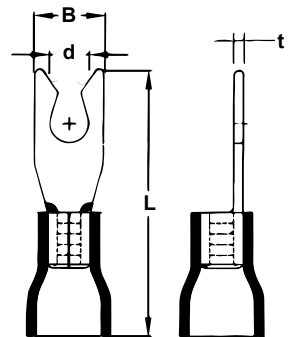



# 902-355 & 902-460 Heat Shrink Tubing

Used for electrical insulation, bundling, and wire identification purposes in a variety of home, commercial, and industrial applications.

**FUNCTION:**

- Slides easily over small inline splices and connectors
- Can shrink down to 50% of its original diameter to fit snugly over any wire, hose or cable management project.
- Ideal way to terminate ends of Braided Sleeving, creating a tight, professional finish.

**160 PIECES: 4" LENGTHS**

1/16"	60 PC
3/32"	35 PC
1/8"	25 PC
3/16"	20 PC
1/4"	10 PC
3/8"	10 PC

**SHRINK RATIO**

**2:1** @ 110°C

**902-355**



**902-460**





**High Quality Bits**

**Slotted Bits**

SL12X1-15/16 ..... 3  
 SL23X1-15/16 ..... 3  
 SL34X1-15/16 ..... 3  
 SL45X1-15/16 ..... 3  
 SL56X1-15/16 ..... 3  
 SL68X1-15/16 ..... 3  
 SL810X1-15/16 ..... 3  
 SL1012X1-15/16 ..... 3  
 SL1214X1-15/16 ..... 3

**Pozidriv Bits**

PZ0X1-15/16 ..... 3  
 PZ1X1-15/16 ..... 3  
 PZ2X1-15/16 ..... 3  
 PZ3X1-15/16 ..... 3  
 PZ4X1-15/16 ..... 3

**Phillips Bits**

PH0X1 ..... 3  
 PH0X1-15/16 ..... 3  
 PH1X1 ..... 3  
 PH1X1-15/16 ..... 3  
 PH2X1 ..... 3  
 PH2X1-15/16 ..... 3  
 PH3X1 ..... 3  
 PH3X1-15/16 ..... 3

**Star-Tip Bits**

T5X1 ..... 4  
 T5X1-15/16 ..... 4  
 T6X1 ..... 4  
 T6X1-15/16 ..... 4  
 T7X1 ..... 4  
 T7X1-15/16 ..... 4  
 T8X1 ..... 4  
 T8X1-15/16 ..... 4  
 T9X1 ..... 4  
 T9X1-15/16 ..... 4  
 T10X1 ..... 4  
 T10X1-15/16 ..... 4  
 T15X1 ..... 4  
 T15X1-15/16 ..... 4  
 T20X1 ..... 4  
 T20X1-15/16 ..... 4  
 T25X1 ..... 4  
 T25X1-15/16 ..... 4  
 T27X1 ..... 4  
 T27X1-15/16 ..... 4  
 T30X1 ..... 4  
 T30X1-15/16 ..... 4

**Tamper Resistant**

**Star-Tip Bits**

T7HX1 ..... 4  
 T7HX1-15/16 ..... 4  
 T8HX1 ..... 4  
 T8HX1-15/16 ..... 4  
 T9HX1 ..... 4  
 T9HX1-15/16 ..... 4  
 T10HX1 ..... 4  
 T10HX1-15/16 ..... 4  
 T15HX1 ..... 4  
 T15HX1-15/16 ..... 4  
 T20HX1 ..... 4  
 T20HX1-15/16 ..... 4  
 T25HX1 ..... 4  
 T27HX1 ..... 4  
 T27HX1-15/16 ..... 4  
 T30HX1 ..... 4  
 T30HX1-15/16 ..... 4

**Special Penta-lobe Security Star Tip**

TS10HX1 ..... 5  
 TS15HX1 ..... 5  
 TS20HX1 ..... 5

**Hex Head Bits**

HX1/1/4X1-15/16 ..... 5  
 HX1/4X1 ..... 5  
 HX1.5X1 ..... 5  
 HX1/8X1 ..... 5  
 HX1/8X1-15/16 ..... 5  
 HX1/16X1 ..... 5  
 HX1/16X1-15/16 ..... 5  
 HX2.5X1 ..... 5  
 HX2X1 ..... 5  
 HX3/16X1 ..... 5  
 HX3/16X1-15/16 ..... 5  
 HX3/32X1 ..... 5  
 HX3/32X1-15/16 ..... 5  
 HX3X1 ..... 5  
 HX4X1 ..... 5  
 HX5/32X1 ..... 5  
 HX5/32X1-15/16 ..... 5  
 HX5/64X1 ..... 5  
 HX5/64X1-15/16 ..... 5  
 HX5X1 ..... 5  
 HX6X1 ..... 5  
 HX7/32X1 ..... 5  
 HX7/32X1-15/16 ..... 5  
 HX7/64X1 ..... 5  
 HX7/64X1-15/16 ..... 5  
 HX7X1 ..... 5  
 HX9/32X1-15/16 ..... 5  
 HX9/64X1 ..... 5  
 HX9/64X1-15/16 ..... 5

**Assortment Packs**

902-390 ..... 6  
 902-391 ..... 6  
 902-392 ..... 6  
 902-393 ..... 6

**Ball Hex Head Bits**

BHX1/4X3-1/2 ..... 6  
 BHX1/8X3-1/2 ..... 6  
 BHX2.5X3-1/2 ..... 6  
 BHX2X3-1/2 ..... 6  
 BHX3/16X3-1/2 ..... 6  
 BHX3/32X3-1/2 ..... 6  
 BHX3X3-1/2 ..... 6  
 BHX4X3-1/2 ..... 6  
 BHX5/32X3-1/2 ..... 6  
 BHX5/64X3-1/2 ..... 6  
 BHX5X3-1/2 ..... 6  
 BHX6X3-1/2 ..... 6  
 BHX7/32X3-1/2 ..... 6  
 BHX7/64X3-1/2 ..... 6  
 BHX9/64X3-1/2 ..... 6

**Spanner Security Bits**

SSP4X1 ..... 6  
 SSP6X1 ..... 6  
 SSP8X1 ..... 6  
 SSP10X1 ..... 6  
 SSP12X1 ..... 6

**Robertson Bits**

S1X1 ..... 6  
 S1X1-15/16 ..... 6  
 S2X1 ..... 6  
 S2X1-15/16 ..... 6  
 S3X1 ..... 6  
 S3X1-15/16 ..... 6  
 S4X1 ..... 6  
 S4X1-15/16 ..... 6

**Power Bits with Spinner Rack**

902-372 ..... 7  
 902-373 ..... 7  
 902-374 ..... 7  
 902-375 ..... 7

902-376 ..... 7  
 902-377 ..... 7  
 902-378 ..... 7  
 902-379 ..... 7  
 902-380 ..... 7  
 902-381 ..... 7

**Cable Ties**

**Hook and Loop Cable Ties**

900-098-AST ..... 9  
 900-098-BK ..... 9  
 900-098-BU ..... 9  
 900-098-GN ..... 9  
 900-098-OR ..... 9  
 900-098-RD ..... 9  
 900-098-WH ..... 9  
 900-098-YL ..... 9

**Nylon Cable Ties**

902-012 ..... 9  
 902-013 ..... 9  
 902-014 ..... 9  
 902-015 ..... 9  
 902-016 ..... 9  
 902-017 ..... 9  
 902-018 ..... 9  
 902-019 ..... 9  
 902-020 ..... 9  
 902-021 ..... 9  
 902-022 ..... 9  
 902-023 ..... 9  
 902-024 ..... 9  
 902-025 ..... 9

**Hook and Loop Cable Tie Material**

902-035 ..... 10  
 902-305 ..... 10  
 902-386 ..... 10  
 902-387 ..... 10  
 902-388 ..... 10  
 902-389 ..... 10

**Splitters**

902-362 ..... 11  
 902-363 ..... 11  
 902-364 ..... 11  
 902-369 ..... 11  
 902-370 ..... 11  
 902-371 ..... 11

**Duplexer**

902-365 ..... 11

**Compression Style Connectors**

**F Type Connectors**

705-001-BK ..... 13  
 705-001-BK-10 ..... 13  
 705-001-BK-20 ..... 13  
 705-001-BK-50 ..... 13  
 705-002-BU ..... 13  
 705-002-BU-10 ..... 13  
 705-002-BU-20 ..... 13  
 705-002-BU-50 ..... 13  
 705-003-BK ..... 13  
 705-003-BK-10 ..... 13  
 705-003-BK-20 ..... 13  
 705-003-BK-50 ..... 13

**BNC Type Connectors**

705-006-BK ..... 13  
 705-006-BK-10 ..... 13  
 705-006-BK-20 ..... 13  
 705-006-BK-50 ..... 13  
 705-007-BU ..... 13  
 705-007-BU-10 ..... 13  
 705-007-BU-20 ..... 13

705-007-BU-50 ..... 13  
 705-008-BK ..... 13  
 705-008-BK-10 ..... 13  
 705-008-BK-20 ..... 13  
 705-008-BK-50 ..... 13

**RCA Type Connectors**

705-004-BK ..... 13  
 705-004-BK-10 ..... 13  
 705-004-BK-20 ..... 13  
 705-004-BU ..... 13  
 705-004-BU-10 ..... 13  
 705-004-BU-20 ..... 13  
 705-004-BU-50 ..... 13  
 705-004-GN ..... 13  
 705-004-GN-10 ..... 13  
 705-004-GN-20 ..... 13  
 705-004-GN-50 ..... 13  
 705-004-RD ..... 13  
 705-004-RD-10 ..... 13  
 705-004-RD-20 ..... 13  
 705-004-RD-50 ..... 13  
 705-004-WH ..... 13  
 705-004-WH-10 ..... 13  
 705-004-WH-20 ..... 13  
 705-004-WH-50 ..... 13  
 705-004-YL ..... 13  
 705-004-YL-10 ..... 13  
 705-004-YL-20 ..... 13  
 705-004-YL-50 ..... 13  
 705-005-BK ..... 13  
 705-005-BK-10 ..... 13  
 705-005-BK-20 ..... 13  
 705-005-BK-50 ..... 13

**Crimp-On, Twist-On, Push-On Connectors**

**F Type Coax Crimp-On Connectors**

902-367-10 ..... 15  
 902-367-100 ..... 15  
 902-382-10 ..... 15  
 902-382-100 ..... 15

**F Type Coax Twist-On Connectors**

902-368-10 ..... 15  
 902-368-10 ..... 15  
 902-384-10 ..... 15  
 902-384-100 ..... 15

**F Type Coax Push-On Connectors**

902-383-10 ..... 15  
 902-383-100 ..... 15

**Wire Ferrules**

**Insulated Wire Ferrules**

300-001 ..... 18  
 300-077 ..... 18  
 300-079 ..... 18  
 300-144 ..... 18  
 701-007 ..... 17  
 701-007-100 ..... 17  
 701-008 ..... 17  
 701-008-100 ..... 17  
 701-010 ..... 17  
 701-010-100 ..... 17  
 701-011 ..... 18  
 701-011-100 ..... 18  
 701-013 ..... 17  
 701-013-100 ..... 17  
 701-014 ..... 18  
 701-014-100 ..... 18  
 701-016 ..... 18  
 701-016-100 ..... 18  
 701-019 ..... 19  
 701-019-100 ..... 19

701-020 ..... 19  
 701-021 ..... 19  
 701-022 ..... 19  
 701-022-100 ..... 19  
 701-023 ..... 18  
 701-023-100 ..... 18  
 701-024 ..... 18  
 701-024-100 ..... 18  
 701-025 ..... 17  
 701-025-100 ..... 17  
 701-026 ..... 17  
 701-026-100 ..... 17  
 701-027 ..... 17  
 701-027-100 ..... 17  
 701-028 ..... 17  
 701-028-100 ..... 17  
 701-029 ..... 18  
 701-029-100 ..... 18  
 701-030 ..... 17  
 701-030-100 ..... 17  
 701-031 ..... 18  
 701-031-100 ..... 18  
 701-032 ..... 18  
 701-032-100 ..... 18  
 701-033 ..... 18  
 701-033-100 ..... 18  
 701-034 ..... 19  
 701-034-100 ..... 19  
 701-035 ..... 19  
 701-035-100 ..... 19  
 701-036 ..... 19  
 701-036-100 ..... 19  
 701-037 ..... 19  
 701-038 ..... 19  
 701-039 ..... 19  
 701-040 ..... 19  
 701-041 ..... 19  
 701-042 ..... 19  
 701-043 ..... 19  
 701-044 ..... 19  
 701-045 ..... 19  
 701-046 ..... 19  
 701-085 ..... 19  
 701-086 ..... 19  
 701-087 ..... 19  
 701-088 ..... 17  
 701-088-100 ..... 17  
 701-097 ..... 17  
 701-097-100 ..... 17  
 701-098 ..... 17  
 701-098-100 ..... 17  
 701-099 ..... 18  
 701-099-100 ..... 18  
 701-100 ..... 18  
 701-100-100 ..... 18  
 701-101 ..... 18  
 701-101-100 ..... 18  
 701-102 ..... 19  
 701-102-100 ..... 19  
 701-103 ..... 19  
 701-103-100 ..... 19  
 701-104 ..... 17  
 701-104-100 ..... 17  
 701-111 ..... 18  
 701-111-100 ..... 18  
 701-113 ..... 19  
 701-113-100 ..... 19  
 701-117 ..... 18  
 701-117-100 ..... 18  
 701-121 ..... 19  
 701-122 ..... 18  
 701-122-100 ..... 18  
 701-130 ..... 18  
 701-130-100 ..... 18  
 701-131 ..... 17

## INDEX (CONTINUED)

701-131-100.....	17	701-049.....	21	701-129.....	21	<b>Cable Detect &amp; Connect</b>	902-419-10.....	38	
701-132.....	18	701-050.....	21	701-136.....	21	902-400.....	35	902-420-10.....	38
701-132-100.....	18	701-051.....	21	701-142.....	21	<b>Terminals</b>		<b>Female Disconnects (Push-Ons)</b>	
701-133.....	19	701-052.....	21	701-146.....	21	<b>Uninsulated Ring Terminals</b>		902-421-10.....	38
701-137.....	19	701-053.....	21	701-147.....	21	<b>(Braze Seam)</b>		902-422-10.....	38
701-138.....	18	701-054.....	21	701-148.....	21	902-406-10.....	37	902-423-10.....	38
701-138-100.....	18	701-055.....	21	902-385.....	23	902-407-10.....	37	902-424-10.....	38
701-140.....	19	701-056.....	21	<b>Crimpers</b>		902-408-10.....	37	902-425-10.....	38
701-145.....	19	701-057.....	21	300-079.....	25	902-409-10.....	37	902-426-10.....	38
701-145-100.....	19	701-058.....	21	902-350.....	25	902-410-10.....	37	<b>Spade Terminals</b>	
701-009.....	20	701-059.....	21	902-348.....	25	902-411-10.....	37	902-448-10.....	39
701-012.....	20	701-060.....	21	902-360.....	25	902-412-10.....	37	902-449-10.....	39
701-015.....	20	701-061.....	21	<b>Strippers and Cutters</b>		902-413-10.....	37	902-450-10.....	39
701-017.....	20	701-062.....	21	902-345.....	27	902-414-10.....	37	902-451-10.....	39
701-018.....	20	701-063.....	21	902-346.....	27	902-415-10.....	37	902-452-10.....	39
701-083.....	20	701-064.....	21	902-349.....	27	902-416-10.....	37	902-453-10.....	39
701-084.....	20	701-065.....	21	902-357.....	28	902-417-10.....	37	902-454-10.....	39
701-089.....	20	701-066.....	21	902-358.....	28	<b>Insulated Ring Terminals (Vinyl)</b>		902-455-10.....	39
701-090.....	20	701-067.....	21	902-359.....	28	902-437-10.....	37	902-456-10.....	39
701-091.....	20	701-068.....	21	200-014.....	28	902-438-10.....	37	902-457-10.....	39
701-112.....	20	701-069.....	21	200-078.....	29	902-439-10.....	37	902-458-10.....	39
701-114.....	20	701-070.....	21	902-344.....	29	902-440-10.....	37	<b>Locking Spade Terminals</b>	
701-116.....	20	701-071.....	21	600-006.....	29	902-441-10.....	37	902-427-10.....	39
701-120.....	20	701-072.....	21	<b>Punch Down Tools and</b>		902-442-10.....	37	902-428-10.....	39
701-135.....	20	701-073.....	21	<b>Tool Kits</b>		902-443-10.....	37	902-429-10.....	39
701-139.....	20	701-074.....	21	902-352.....	31	902-444-10.....	37	902-430-10.....	39
701-143.....	20	701-075.....	21	902-341.....	31	902-445-10.....	37	902-431-10.....	39
<b>Wire Ferrule Assortment Pack</b>		701-076.....	21	902-347.....	31	902-446-10.....	37	902-432-10.....	39
701-998.....	20	701-077.....	21	902-356.....	31	902-447-10.....	37	902-433-10.....	39
<b>Uninsulated Wire Ferrules</b>		701-078.....	21	<b>Tool Bundles</b>		<b>Closed End Connectors</b>		902-434-10.....	39
701-001.....	21	701-079.....	21	902-340.....	33	902-402-10.....	38	902-435-10.....	39
701-002.....	21	701-080.....	21	902-351.....	33	902-403-10.....	38	902-436-10.....	39
701-003.....	21	701-081.....	21	902-353.....	33	902-404-10.....	38	<b>Heat Shrink Tubing</b>	
701-004.....	21	701-082.....	21	902-354.....	34	902-405-10.....	38	902-355.....	40
701-005.....	21	701-115.....	21	902-361.....	34	<b>Butt Splices</b>		902-460.....	40
701-006.....	21	701-125.....	21			902-418-10.....	38		
701-047.....	21	701-126.....	21						
701-048.....	21	701-127.....	21						
		701-128.....	21						



**eclipse**<sup>SM</sup>  
YOUR COMPLETE TOOL & ACCESSORY SOURCE

Eclipse Enterprises, Inc. • Tel: 804.561.2610 • Fax: 804.561.2642  
13302 Chula Road, Amelia Court House, VA 23002 • [EclipseTools.com](http://EclipseTools.com)