

# Series 805 Mighty Mouse Triple-Start Crimp Receptacle Ordering Information

805-003 and 805-004



**Series 805 Triple-Start Jam Nut Connector**

### Three Shell Mounting Options

Jam nut with O-ring for rear panel mounting, square flange for front or rear panel mounting, or in-line receptacles for free-hanging cables.

**Gold-Plated Crimp Contacts** are held in place with beryllium copper retention clips. Contacts are removable.

**Two Shell Styles:** Choose **integral band platform** for direct attachment of a cable shield. Install a boot, or overmold a boot over the band platform. An **accessory thread** is available for attaching strain reliefs and backshells.

## HOW TO ORDER

### Sample Part Number

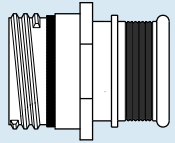
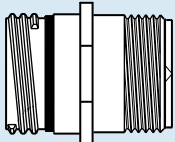
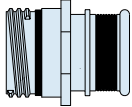
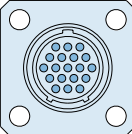
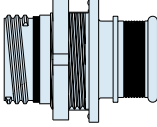
805-004	-02	NF	9-10	P	A
Series	Shell Style	Shell Material / Finish	Shell Size- Insert Arrangement	Contact Type	Shell Key Position
 <p><b>805-003</b> Receptacle with Banding Platform</p>  <p><b>805-004</b> Receptacle with Accessory Thread</p>	 <p><b>-01</b> In-Line</p>  <p><b>-02</b> Square Flange</p>  <p><b>-07</b> Jam Nut for Rear Panel Mounting</p>	<p><b>C</b> Aluminum / Black Anodize (Non-Conductive) RoHS Compliant</p> <p><b>M</b> Aluminum / Electroless Nickel RoHS Compliant</p> <p><b>NF</b> Aluminum / Cadmium with Olive Drab Chromate</p> <p><b>ZN</b> Aluminum / Zinc-Nickel with Olive Drab Chromate</p> <p><b>ZNU</b> Aluminum / Zinc-Nickel with Black Chromate</p> <p><b>MT</b> Aluminum / Nickel-PTFE RoHS Compliant</p> <p><b>Z1</b> Stainless Steel / Passivated RoHS Compliant</p>	<p>SEE <b>CONTACT ARRANGEMENTS</b> PAGE H-2</p>	<p><b>Connector supplied with contacts</b></p> <p><b>P</b> Pin</p> <p><b>S</b> Socket</p> <p><b>Connector supplied without contacts</b></p> <p><b>A</b> Pin Connector, less contacts</p> <p><b>B</b> Socket Connector, less contacts</p> <p>Connectors with contacts are supplied with signal and/or power crimp contacts. These contacts are not installed.</p> <p>Coaxial contacts and non-standard signal contacts are ordered separately.</p>	<p><b>A</b> Position A (Normal)</p> <p><b>B</b> Position B</p> <p><b>C</b> Position C</p> <p><b>D</b> Position D</p>

Dimensions in inches (millimeters) and are subject to change without notice.

# Series 805 Mighty Mouse Triple-Start In-Line Receptacle Dimensions

805-003-01 and 805-004-01

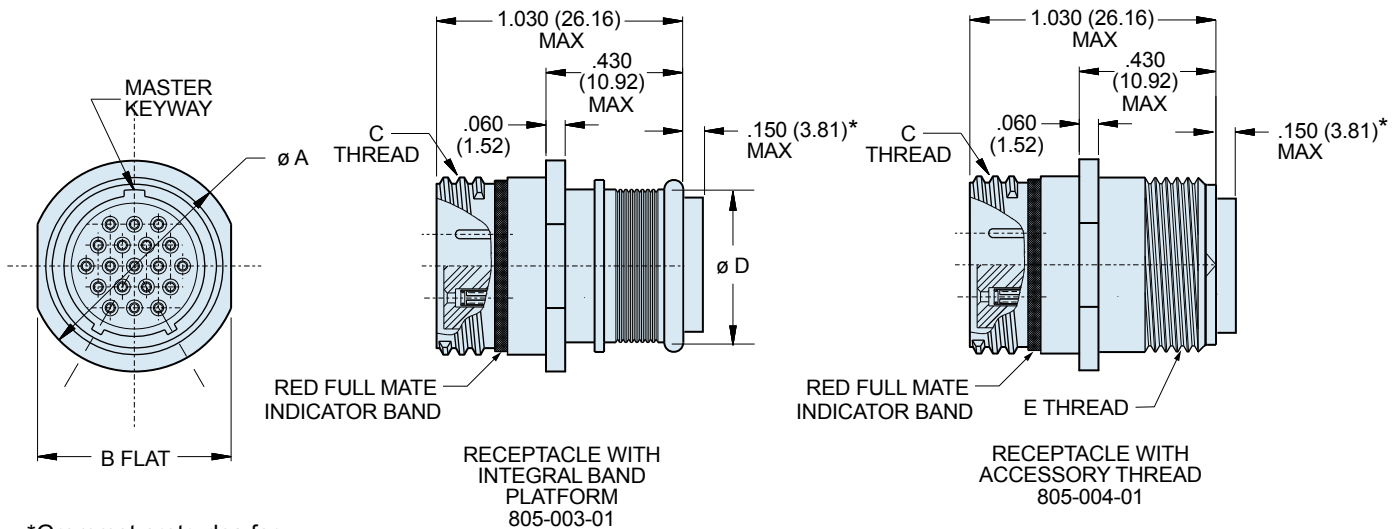

\*Grommet protrudes for power/combo arrangements

## DIMENSIONS

Shell Size	Ø A		B		C Threads	Ø D		E Threads Accessory
	In.	mm.	In.	mm.		In.	mm.	
8	.540	13.72	.510	12.95	.5000-.1P-.3L-TS-2A	.316	8.05	.3750-32 UNEF-2A
9	.605	15.37	.575	14.61	.5625-.1P-.3L-TS-2A	.397	10.08	.4375-28 UNEF-2A
10	.668	16.96	.638	16.21	.6250-.1P-.3L-TS-2A	.472	12.01	.5000-28 UNEF-2A
11	.730	18.54	.700	17.78	.6875-.1P-.3L-TS-2A	.519	13.18	.5625-24 UNEF-2A
12	.793	20.14	.763	19.38	.7500-.1P-.3L-TS-2A	.585	14.86	.6250-24 UNEF-2A
15	.980	24.89	.950	24.13	.9375-.1P-.3L-TS-2A	.687	17.45	.7500-20 UNEF-2A
18	1.165	29.59	1.135	28.83	1.1250-.1P-.3L-TS-2A	.884	22.45	.9375-20 UNEF-2A
19	1.235	31.37	1.205	30.61	1.1875-.1P-.3L-TS-2A	.884	22.45	.9375-20 UNEF-2A
23	1.485	37.72	1.455	36.96	1.4375-.1P-.3L-TS-2A	1.134	28.80	1.1875-18 UNEF-2A

## PERFORMANCE SPECIFICATIONS

DWV	#23 500 VAC Sea level, #20HD 750 VAC, #12 AND #16 1800 VAC
Insulation Resistance	5000 Megohms Minimum
Operating Temperature	-55° C. to +150° C.
Immersion, Mated	MIL-STD-810 Method 512. One Meter for One Hour.
EMI	65 dB Minimum from 1 GHz. to 10 GHz.

## MATERIALS AND FINISHES

Connector Shell	Aluminum or Stainless Steel
Insulator	Liquid Crystal Polymer (LCP)
Seals	Fluorosilicone Rubber, Blue
Pin Contact	Copper Alloy, Gold over Nickel Plating
Socket Contact	Copper Alloy, Gold over Nickel Plating, with SST Hood
Contact Retainer Clip	Beryllium Copper, Unplated

## SERIES 805 KEY POSITIONS

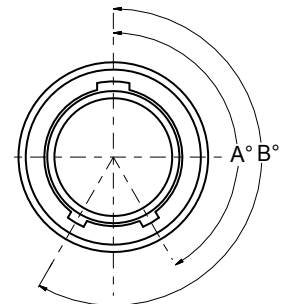

Key Position	Key Rotation	
	A	B
Normal (A)	150°	210°
B	75°	210°
C	95°	230°
D	140°	275°

Dimensions in inches (millimeters) and are subject to change without notice.

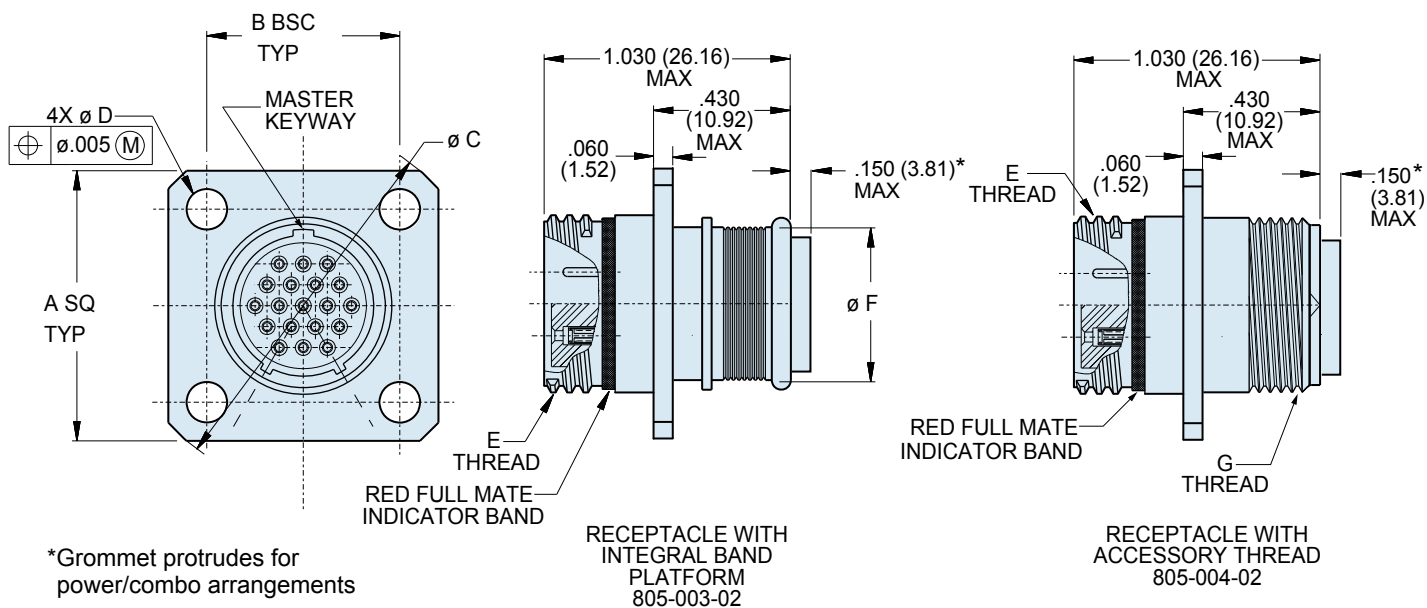

**DIMENSIONS**

Shell Size	A		B		ØC		ØD		E Threads	Ø F		G Threads Accessory
	In.	mm.	In.	mm.	In.	mm.	In. ± .003	mm. ± .08		In.	mm.	
8	.850	21.59	.660	16.76	1.150	29.21	.094	2.39	.5000-.1P-.3L-TS-2A	.316	8.05	.3750-32 UNEF-2A
9	.913	23.19	.723	18.36	1.230	31.24	.094	2.39	.5625-.1P-.3L-TS-2A	.397	10.08	.4375-28 UNEF-2A
10	.975	24.77	.785	19.94	1.330	33.78	.094	2.39	.6250-.1P-.3L-TS-2A	.472	12.01	.5000-28 UNEF-2A
11	1.039	26.39	.848	21.54	1.410	35.81	.094	2.39	.6875-.1P-.3L-TS-2A	.519	13.18	.5625-24 UNEF-2A
12	1.099	27.91	.909	23.09	1.500	38.10	.094	2.39	.7500-.1P-.3L-TS-2A	.585	14.86	.6250-24 UNEF-2A
15	1.288	32.74	1.058	26.87	1.750	44.45	.128	3.25	.9375-.1P-.3L-TS-2A	.687	17.45	.7500-20 UNEF-2A
18	1.475	37.47	1.255	31.88	2.000	50.80	.128	3.25	1.1250-.1P-.3L-TS-2A	.884	22.45	.9375-20 UNEF-2A
19	1.537	71.06	1.327	33.71	2.094	53.19	.128	3.25	1.1875-.1P-.3L-TS-2A	.884	22.45	.9375-20 UNEF-2A
23	1.787	45.39	1.570	39.88	2.440	61.98	.128	3.25	1.4375-.1P-.3L-TS-2A	1.134	28.80	1.1875-18 UNEF-2A

**PERFORMANCE SPECIFICATIONS**

DWV	#23 500 VAC Sea level, #20HD 750 VAC, #12 AND #16 1800 VAC
Insulation Resistance	5000 Megohms Minimum
Operating Temperature	-55° C. to +150° C.
Immersion, Mated	MIL-STD-810 Method 512. One Meter for One Hour.
EMI	65 dB Minimum from 1 GHz. to 10 GHz.

**MATERIALS AND FINISHES**

Connector Shell	Aluminum or Stainless Steel
Insulator	Liquid Crystal Polymer (LCP)
Seals	Fluorosilicone Rubber, Blue
Contact	Copper Alloy, Gold over Nickel Plating
Contact Retainer Clip	Beryllium Copper, Unplated

**SERIES 805 KEY POSITIONS**

Key Position	Key Rotation	
	A	B
Normal (A)	150°	210°
B	75°	210°
C	95°	230°
D	140°	275°

Dimensions in inches (millimeters) and are subject to change without notice.

# Series 805 Mighty Mouse Triple-Start Jam Nut Receptacle Dimensions

805-003-07 and 805-004-07

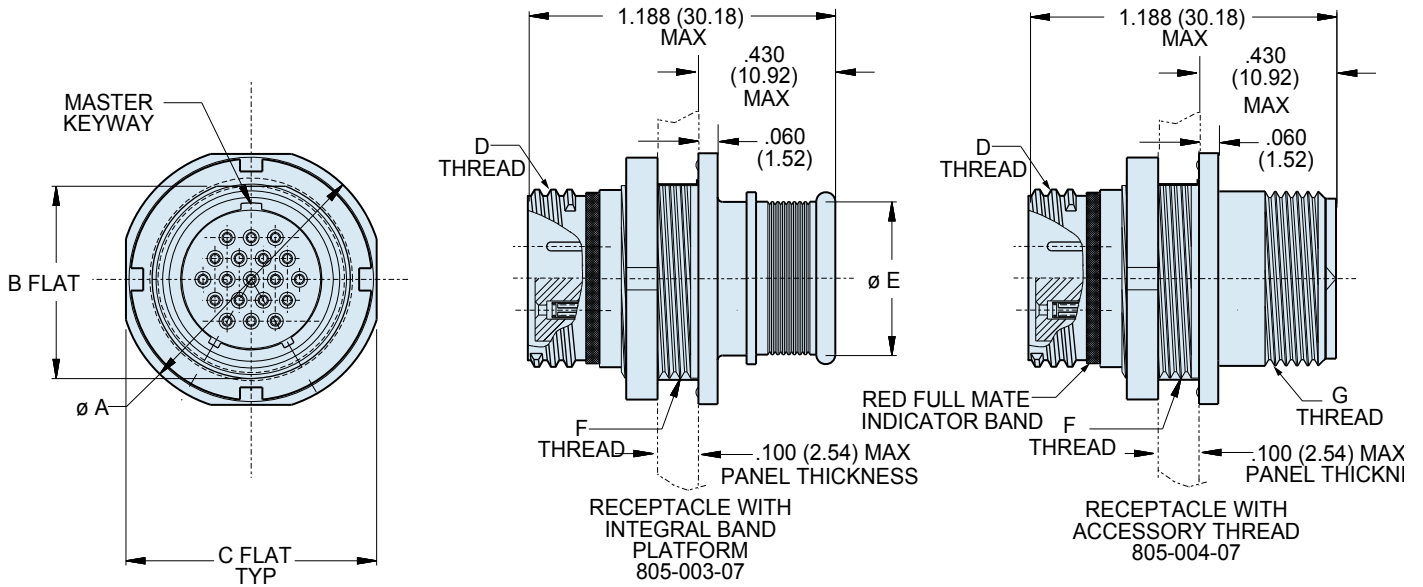

## DIMENSIONS

Shell Size	Ø A		B		C		D Threads	Ø E		F Threads	G Threads Accessory
	In.	mm.	In.	mm.	In.	mm.		In.	mm.		
8	.760	19.30	.535	13.59	.730	18.54	.5000-1P-.3L-TS-2A	.317	8.05	.5625-28 UNEF-2A	.3750-32 UNEF-2A
9	.880	22.35	.661	16.79	.850	21.59	.5625-1P-.3L-TS-2A	.397	10.08	.6875-28 UN-2A	.4375-28 UNEF-2A
10	.880	22.35	.661	16.79	.850	21.59	.6250-1P-.3L-TS-2A	.473	12.01	.6875-28 UN-2A	.5000-28 UNEF-2A
11	.955	24.26	.721	18.31	.925	23.50	.6875-1P-.3L-TS-2A	.519	13.18	.7500-28 UN-2A	.5625-24 UNEF-2A
12	1.060	26.92	.784	19.91	1.035	26.29	.7500-1P-.3L-TS-2A	.585	14.86	.8125-28 UN-2A	.6250-24 UNEF-2A
15	1.203	30.56	.970	24.64	1.173	29.79	.9375-1P-.3L-TS-2A	.687	17.45	1.0000-28 UN-2A	.7500-20 UNEF-2A
18	1.389	35.28	1.147	29.13	1.359	34.52	1.1250-1P-.3L-TS-2A	.884	22.45	1.1875-28 UN-2A	.9375-20 UNEF-2A
19	1.450	36.83	1.221	31.01	1.420	36.07	1.1875-1P-.3L-TS-2A	.884	22.45	1.2500-28 UN-2A	.9375-20 UNEF-2A
23	1.705	43.31	1.470	37.34	1.675	42.55	1.4375-1P-.3L-TS-2A	1.134	28.80	1.500-25 UN-2A	1.1875-18 UNEF-2A

## PANEL CUTOUT FOR JAM NUT RECEPTACLE

Shell Size	A Flat		Ø B	
	In. ± .002	mm. ± 0.05	In. ± .005	mm. ± 0.13
8	.543	13.79	.572	14.53
9	.669	16.99	.698	17.73
10	.669	16.99	.698	17.73
11	.729	18.51	.760	19.30
12	.792	20.17	.822	20.88
15	.978	24.84	1.010	25.65
18	1.155	29.34	1.198	30.43
19	1.231	31.27	1.260	32.00
23	1.480	37.59	1.510	38.35

## SERIES 805 KEY POSITIONS

Key Position	Key Rotation	
	A	B
Normal (A)	150°	210°
B	75°	210°
C	95°	230°
D	140°	275°

Dimensions in inches (millimeters) and are subject to change without notice.