

Double break

→ PBX Secure

- Conforming to standard DIN 41 636 type F
- Double break electrically-isolated changeover circuit (form Zb)
- IP 40 or IP 67 versions
- Operating temperature between -50 and +85°C
- Long overtravel
- Standard or Low level version
- Positive break mechanism according to IEC 60947-5-1



Caractéristiques

	Standard 83240	Standard High force 83242	Low level 83241	Low level High force 83243
Sealing				
IP 40 *	W3			
IP 40 *	W3 + Lever only			
IP 40 *	W3 + Lever + Mounting plate with holes			
IP 40 *	W3 + Lever + Mounting plate with notches			
IP 40 *	W5			
IP 40 *	W5 + Lever only			
IP 40 *	W5 + Lever + Mounting plate with holes			
IP 40 *	W5 + Protective cover			
IP 67 *	W3			
IP 67 *	W3 90° + Lever only			
IP 67 *	W5			
IP 67	W3 + Lever only			
IP 67	W5 + Lever only			
IP 67	W5 + Lever only + Mounting plate with holes			
Electrical characteristics				
Rating nominal / 250 V ^a (A)	6	6	-	-
Rating nominal / 250 V ^c (A)	0.2 → 0.5	0.2 → 0.5	-	-
Rating Thermal (A)	10	10	-	-
Rating nominal / 4 → 30 V ^c (A)	-	-	0.01	0.01
Mechanical characteristics				
Maximum operating force (N)	4.5	6.5	4.5	6.5
Rest position max. (mm)	8.9	8.9	8.9	8.9
Operating position (mm)	6.6 ±0.25 **	6.6 ±0.25 **	6.6 ±0.25 **	6.6 ±0.25 **
Maximum positive opening position (mm)	4.4 **	4.4 **	4.4 **	4.4 **
End of travel position (mm)	3.4 max. **	3.4 max. **	3.4 max. **	3.4 max. **
Maximum differential travel (mm)	1 ±0.3	1 ±0.3	1 ±0.3	1 ±0.3
Operating temperature (°C)	-50 → +85	-50 → +85	-50 → +85	-50 → +85
Mechanical life (operations)	10 ⁷ ***	10 ⁷ ***	10 ⁷ ***	10 ⁷ ***
Contact gap (mm)	0.5 x 2	0.5 x 2	0.3 x 2	0.3 x 2
Tightening torque (Nm)	1.3 max.	1.3 max.	1.3 max.	1.3 max.
Weight (g)	22 **	22 **	22 **	22 **
Comments				

* Both the W3 and W5 connectors are IP 00

** Values given for versions without lever (in relation to the reference dimension X0 - See Dimensions section).

*** With front-end actuation and for IP 40 version.

5 x 10⁶ guaranteed for IP 67 versions.

Product adaptations



- Special protective cover
- Wire outputs, cable outputs
- Special levers and actuators
- Connections : connectors folded at an angle between 0 and 90°, special additional connectors
- UL, CSA, CCE and VDE certification on request

Principles

Function

Four-terminal double break two-way contact element (form Zb). The 2 moving contacts are electrically isolated from one another.

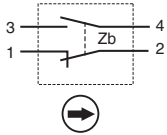

Additional characteristics

Components

Material

- Case/cover : 20% glass reinforced polycarbonate. Material classed as I2F1 according to standard NFF 16-101/102
- Contacts: AgNi for Standard version and AgPd for low level version
- Terminals: Tinned brass
- Button membrane: Silicon

Conformity to standards

- Dimensions conforming to standard DIN 41 636 type F
- Insulation stress according to standard IEC 60947-5-1
 - * Overvoltage category: III Uimp = 4 KV
 - * Local voltage: Ui = 400 V
 - * Degree of pollution = 3 for IP 40 versions and 1 for IP 67 versions
- Insulation stress according to standard EN 50124-1
 - * Overvoltage category: OV3 Uimp = 2.5 KV
 - * Local voltage: U < 110 V
 - * Degree of pollution = PD3A for IP 40 versions and PD2 for IP 67 versions

Electrical protection

- Short-circuit protection device according to standard EN 60947-5-1, 6 AgG fuse

Curves

Operating curve for type AC15

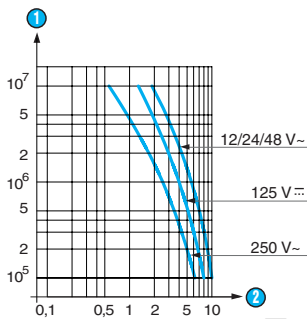

- ① Number of operations
- ② Current in Amps

Operating curve for type DC13

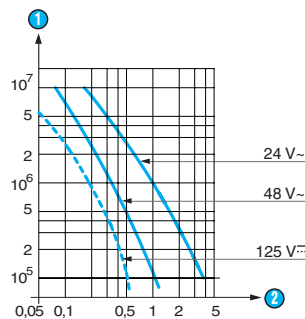

For IP 67 versions and operating curve at 125 V DC:
Please consult Crouzet

Dimensions (mm)

→ Product

83240 - 83241 - 83242 - 83243

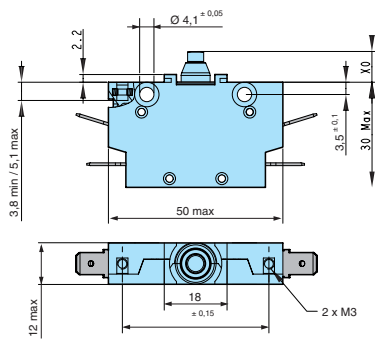

→ Connections

W3 for 6.35 mm clips

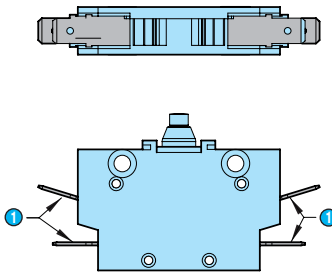

1 Connectors folded 90° are available on request

W5 with screw

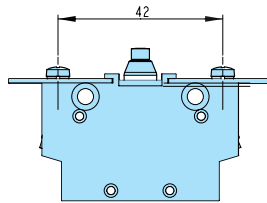

W5 with screw and protective cover

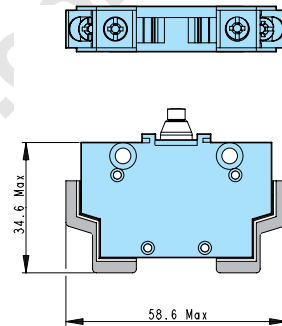

→ Mounting accessories

Plunger with plates with holes

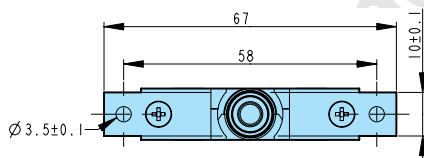

Plunger with plates with notches

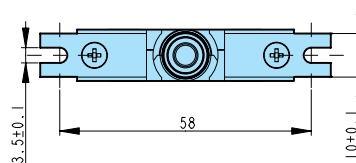

→ Actuators

Roller lever

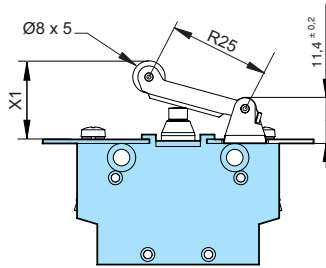

Table of positions for lever versions

Rest position max. (mm) relative to X1 reference	21
Operating position (mm)	16,6±0,6
Maximum positive opening position (mm)	13,2
End of travel position (mm)	12
Maximum differential travel (mm)	1,8±0,55

Other information

PRODUCT CODING TABLE 8324xxxx

8324Xxxx (Contact/Force)

- 0: Standard/4,5 N
- 1: Low level/4.5 N
- 2: Standard/6.5 N High force
- 3: Low level/6.5 N High force

8324xXxx (Seal)

- 0: IP 40
- 2: IP 67

8324xxXx (Connection)

- 0: W3 connectors for 6.35 mm clips
- 1: W3 90B connectors folded 90° for 6.35 mm clips
- 2: W5 connectors with screw
- 3: W5 connectors with screw and protective cover
- 4: W5 connectors supplied without screws

8324xxxX (Accessory)

- 0: Plunger
- 1: Plunger with plates with holes
- 2: Plunger with plates with notches
- 3: Roller lever (flush plate)
- 4: Roller lever with plates with holes
- 5: Roller lever with plates with notches

Example:

A PBX with Standard contact (AgNi), 6N force, IP 67 seal, W3 connectors and Roller lever accessory with plates with holes = **83242204**