

DASH NO.	M CODE	MADE FROM
----------	--------	-----------

SD

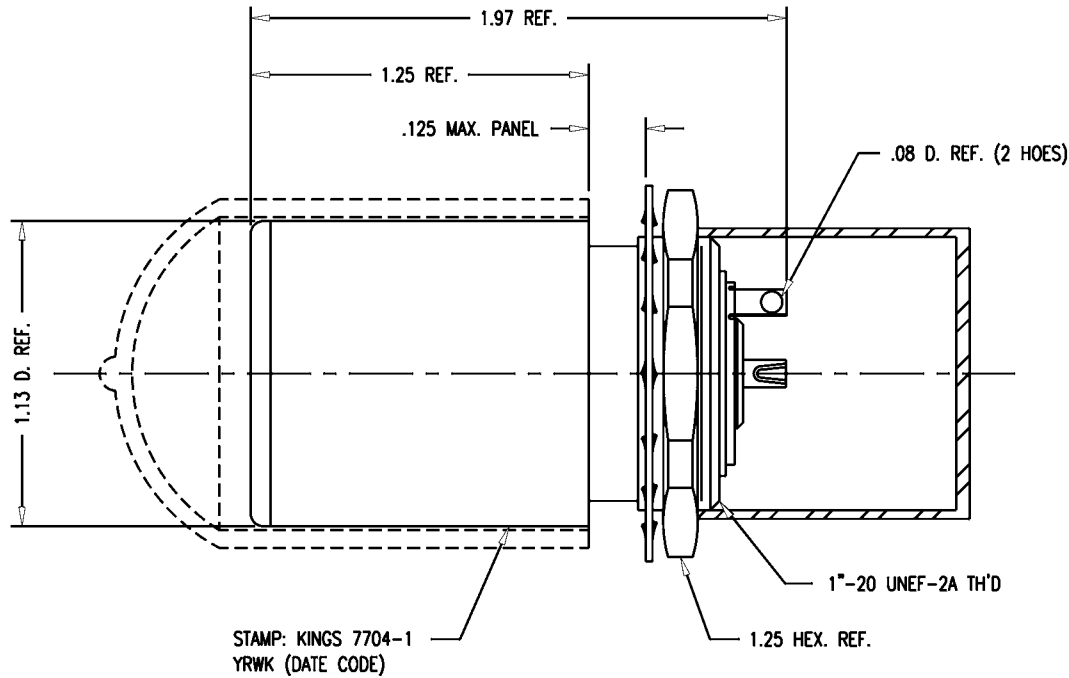

STAMP: KINGS 7704-1
YRWK (DATE CODE)

NOTES:

- MATERIALS:
 - INSULATORS: TEFLON, ASTM-D-4894
 - CAP: VINYL
 - CENTER CONTACT } BER. COP., ASTM-B-196
 - OUTER CONTACT SPRING }
 - INSERT }
 - LOCKWASHER: PHOSPHOR BRONZE, ASTM-B-103
 - ALL OTHER METAL PARTS: BRASS, ASTM-B16
- FINISHES:
 - OUTER CONTACT SPRING } GOLD PLATE PER MIL-G-45204
 - CENTER CONTACT }
 - ALL OTHER METAL PARTS: KINGS TARNISH RESISTANT NICKEL FINISH (TR-5)
- ELECTRICAL CHARACTERISTICS:
 - NOMINAL IMPEDANCE: 75 OHMS
 - FREQUENCY RANGE: DC-500 MHZ
 - VOLTAGE BREAKDOWN: CENTER CONDUCTOR/INNER GROUND: 1500 VOLTS RMS
 - INNER GROUND/OUTER GROUND: 500 VOLTS RMS

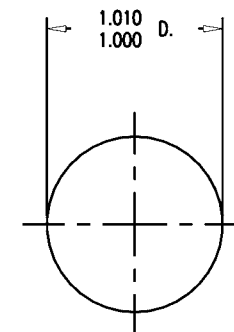

MOUNTING HOLE

7704-1

REVISIONS

ISSUE	CHANGES
0	ER 35437 KH 04/19/95
1	CN 36754 E ME 12/22/95
2	CN 37274 D PG 03/12/97
3	CN 37336 D PG 04/07/97
4	CN 37424 C MRM 08/26/97
5	CN 38122 C BDH 11/07/00

77041C

SCALE 2:1	
APPROX SURFACE AREA	
USED ON	
REF: KP-8060-001-000	
RECEPTACLE, BKHD, TRI-LOC SERIAL DIGITAL	
DRAWN ME	DATE 10/31/95
DESIGN FD	DATE 10/31/95
APPR.	DATE

KINGS
ELECTRONICS CO., INC.
ROCK HILL, SOUTH CAROLINA 29730

SD

7704-1