

Setting Standards

Circular Connectors



2009

HUMMEL AG

Located north of Freiburg, Germany, in the towns of Waldkirch and Denzlingen near the intersection of the French, German, and Swiss borders, HUMMEL was established over sixty years ago.

In 1948

Establishment of Anton Hummel Metallwarenfabrik, a metal working factory, to produce turned metal components and assemblies for electrical, heating and sanitary installations.

In 1970

HUMMEL commences plastic processing.

In 1985

HUMMEL builds on a solid foundation by acquiring F&P Electronics, now HUMMEL EL, a division offering electronic component assemblies and self-developed systems.

In 1987

HUMMEL invests in and introduces a fully-automated electroplating production line.

1994 – 2005

HUMMEL develops an international presence, establishing factories and sales

offices in Hungary, China, Italy, Russia, Brazil, and the United Kingdom.

In 2008

HUMMEL incorporates and expands its German headquarters to include new logistics and manufacturing facilities. Global expansion continues with the establishment of a new facility in India. By doing development, construction, tool manufacture, production, electroplating and assembly under one roof, HUMMEL AG strengthens its global role as a reliable partner in new and developing markets.

HUMMEL AG capitalizes on its collective knowledge to set standards in the following product areas:

- Cable glands, cable management systems, circular metal connectors, box enclosure fittings
- Temperature controllers, operating panels, industrial loading technology, sensor technology, controls
- System solutions, front panels, customised housings, cable assembly
- Customised metal and plastic parts
- Radiator valves and fittings, design technology

HUMMEL AG is a family-owned German business that takes pride in its achievements. Its independent operation, free from the influence of outside groups, has transformed HUMMEL into a market leader responsible for numerous patents, innovations and technological developments. Its vertical integration contributes to the organization's flexibility and focus of targeting success. The strength of HUMMEL's reputation can be attributed to the functionality of its comprehensive system solutions and state of the product range that's true to, the company's motto: Setting Standards.

HUMMEL's extensive product range and ability to fulfill product requests on demand enable it to provide the highest level of customer service. Whether in partnership with its customers or independently, HUMMEL applies its extensive experience and unique approach to the establishment of new standards as it develops innovative solutions for its customers.

HUMMEL's eco-friendly products are manufactured in accordance with ISO 9001:2000.

Company History



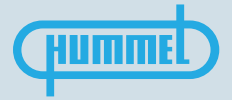

The Products

Product Range

- Liquid tight strain relief and conduit fittings
- Circular Connectors
- Industrial Enclosures
- Sensing and Control Devices
- Precision turned parts
- Radiator Valves and Fittings
- Installation Enclosures



To request catalog:
info@hummel.com

Cable Glands



Industrial Enclosures



M 23 Profinet

- + Data transfer up to Gigabit rate, Multibus II capability
- + Hybrid connectors for single-cable solutions
- + Five separate shield potentials available
- + Rugged, safe, compact: ideal for use in rough industrial environments



Robust – simple & small!

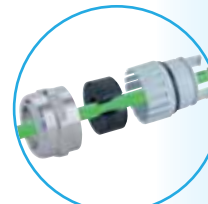

Design allows for terminated patch cable

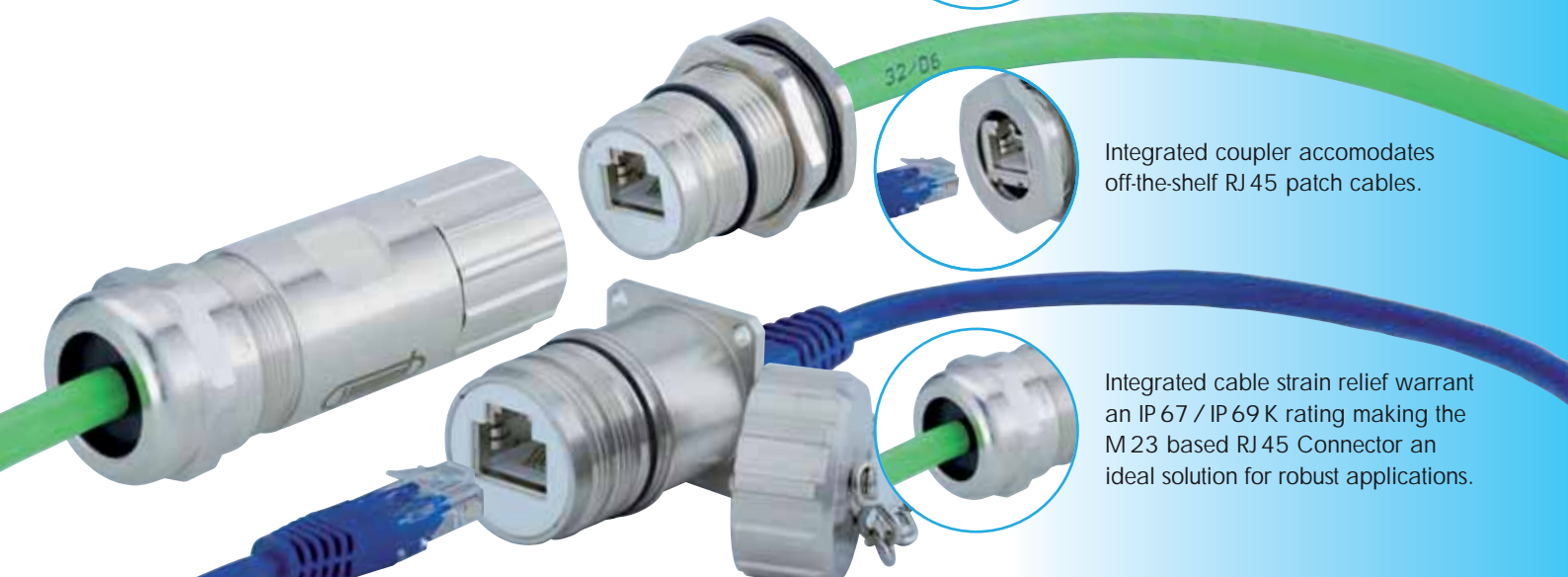

Integrated coupler accommodates off-the-shelf RJ45 patch cables.



Integrated cable strain relief warrant an IP 67 / IP 69 K rating making the M23 based RJ45 Connector an ideal solution for robust applications.



A standard RJ45 connection is suitable as service and programmable interface.

User friendly assembly

- + Clear and modular structure of all connector series
- + Patented modular strain relief insert and contact insert
- + One step cable assembly and shielding
- + Simple, quick and reliable assembly into the connector housing



Colour coding of spacers for male and female inserts



Cable assembly and shielding is possible in a single operation.



Strain relief insert with four fingers, secured in a recess, prevents cable rotation.



Flexible EMC-O-ring guarantees reliable EMC-protection for light and heavy braided shields.

Get to the point



Flexibility due to modularity. Male and female Contact Inserts work with all different style M23 Power Connectors



The versatility of Hummel Connectors with only a few parts makes assembly and wiring cost effective.



SLS-Technology

The new, high performance type of contacts – HUMMEL SLS-Technology (Spring Loaded Socket)

- + Integrated spring mates with the pin contact and encompasses it radially
- + Exceptional electrical performance with ultimate contact reliability
- + Tinned solder contacts assure easy and quick assembly

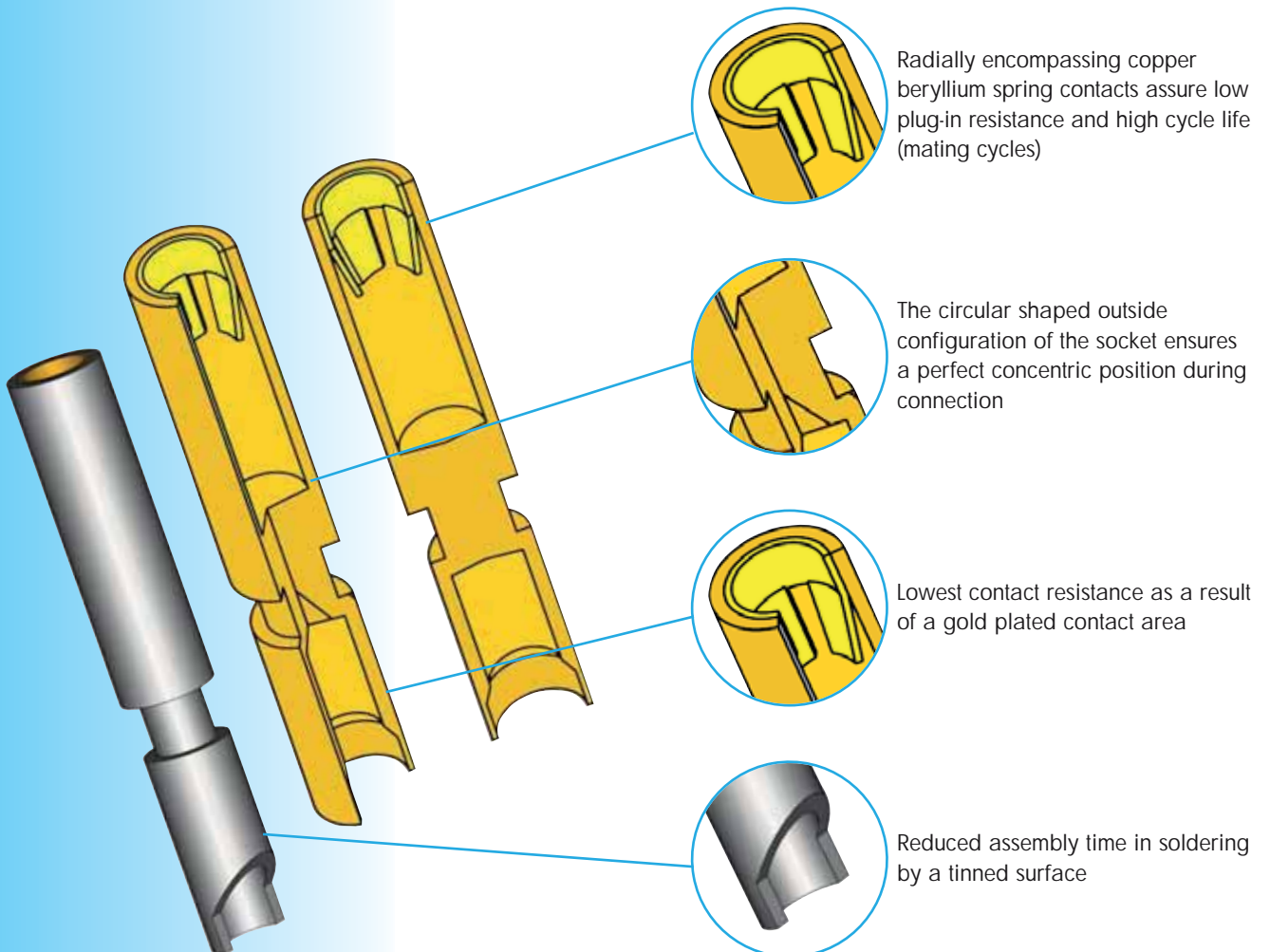

Euro-Lock-System[®]

Euro-Lock-System[®] – the patented locking system

- + The integrated locking clip secures the contacts in the insert
- + Easy assembly and disassembly of the contacts
- + No special tools required

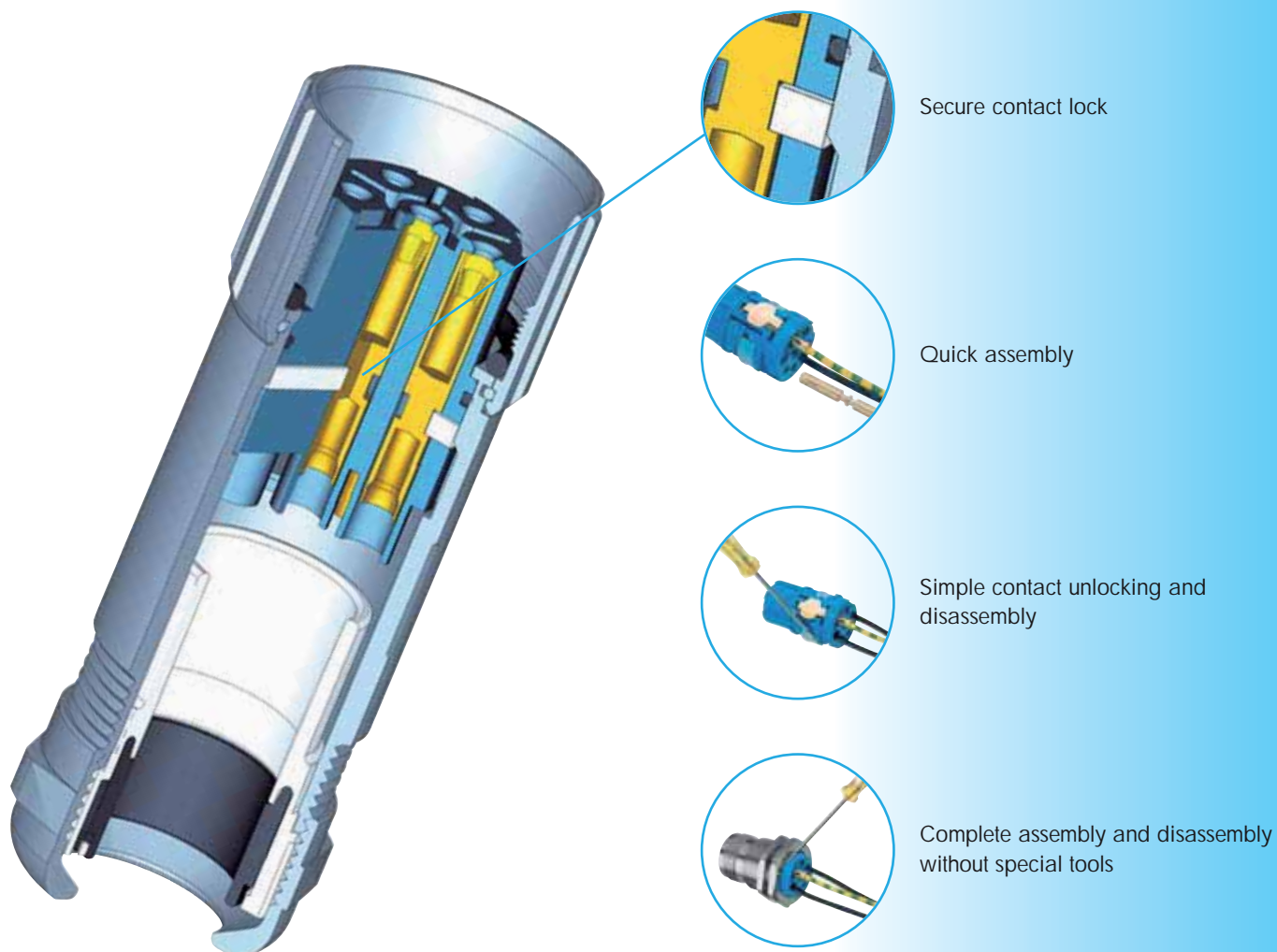

Push-Pull Technology

- + One for all: Standard male connectors accept HUMMEL Push-Pull as well as screw connection
- + EMC proof due to metal sleeve
- + Optional safety ring

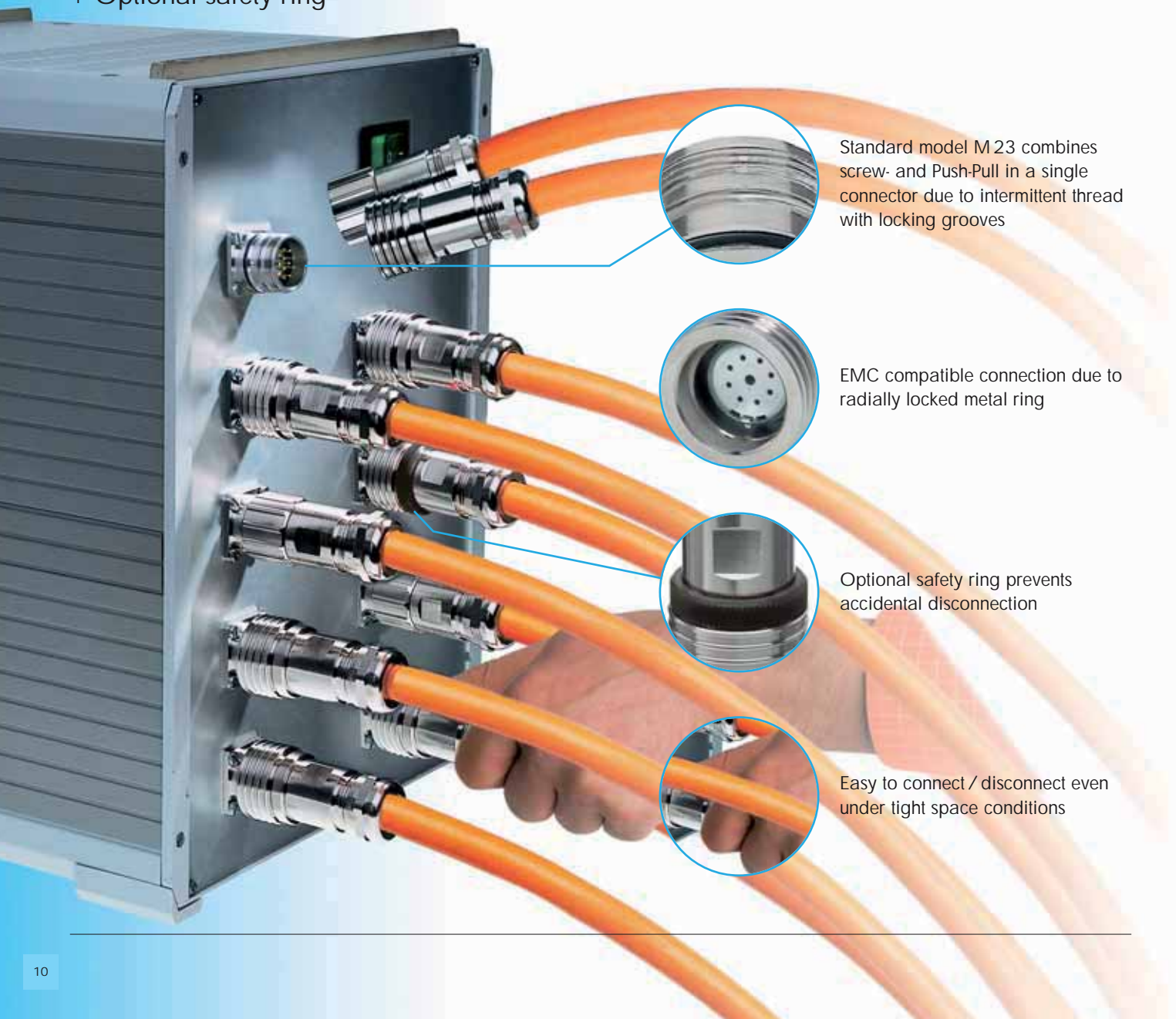

Standard model M23 combines screw- and Push-Pull in a single connector due to intermittent thread with locking grooves

EMC compatible connection due to radially locked metal ring

Optional safety ring prevents accidental disconnection

Easy to connect / disconnect even under tight space conditions

Unique Benefits

- + Interchangeability of pin or socket inserts in every style connector housing
- + HUMMEL's patented integrated HSK Liquid Tight Strain Relief Fitting
- + Internationally certified exceptional quality



File-No. E 213337



Germanischer Lloyd

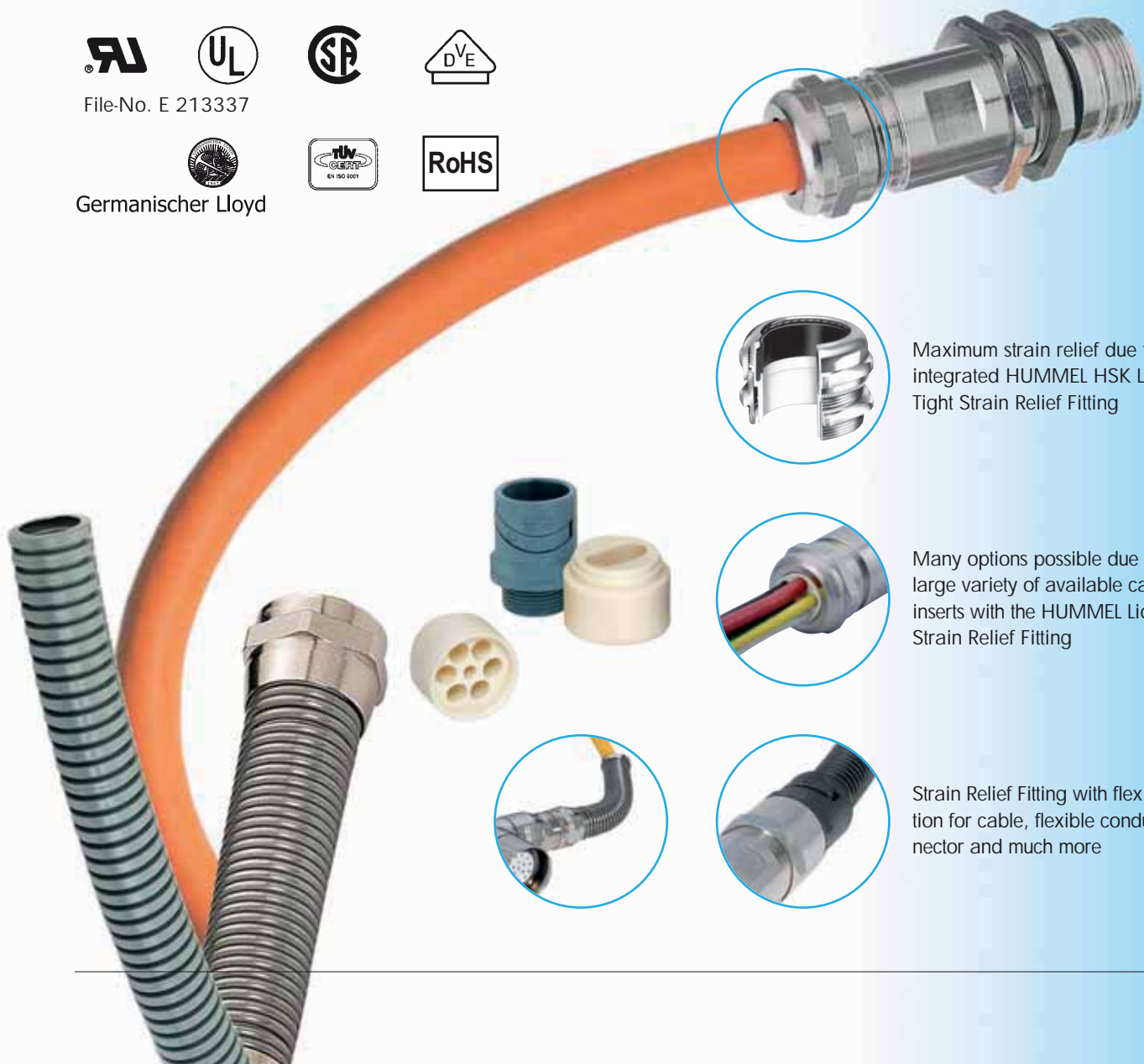

Maximum strain relief due to the integrated HUMMEL HSK Liquid Tight Strain Relief Fitting



Many options possible due to the large variety of available cable seal inserts with the HUMMEL Liquid Tight Strain Relief Fitting



Strain Relief Fitting with flex protection for cable, flexible conduit connector and much more

The Insert – One for all

- + Insert can be used for all types of contacts
- + Crimp contacts machined or on tape
- + Solder contacts for manual soldering or dip soldered for PC boards

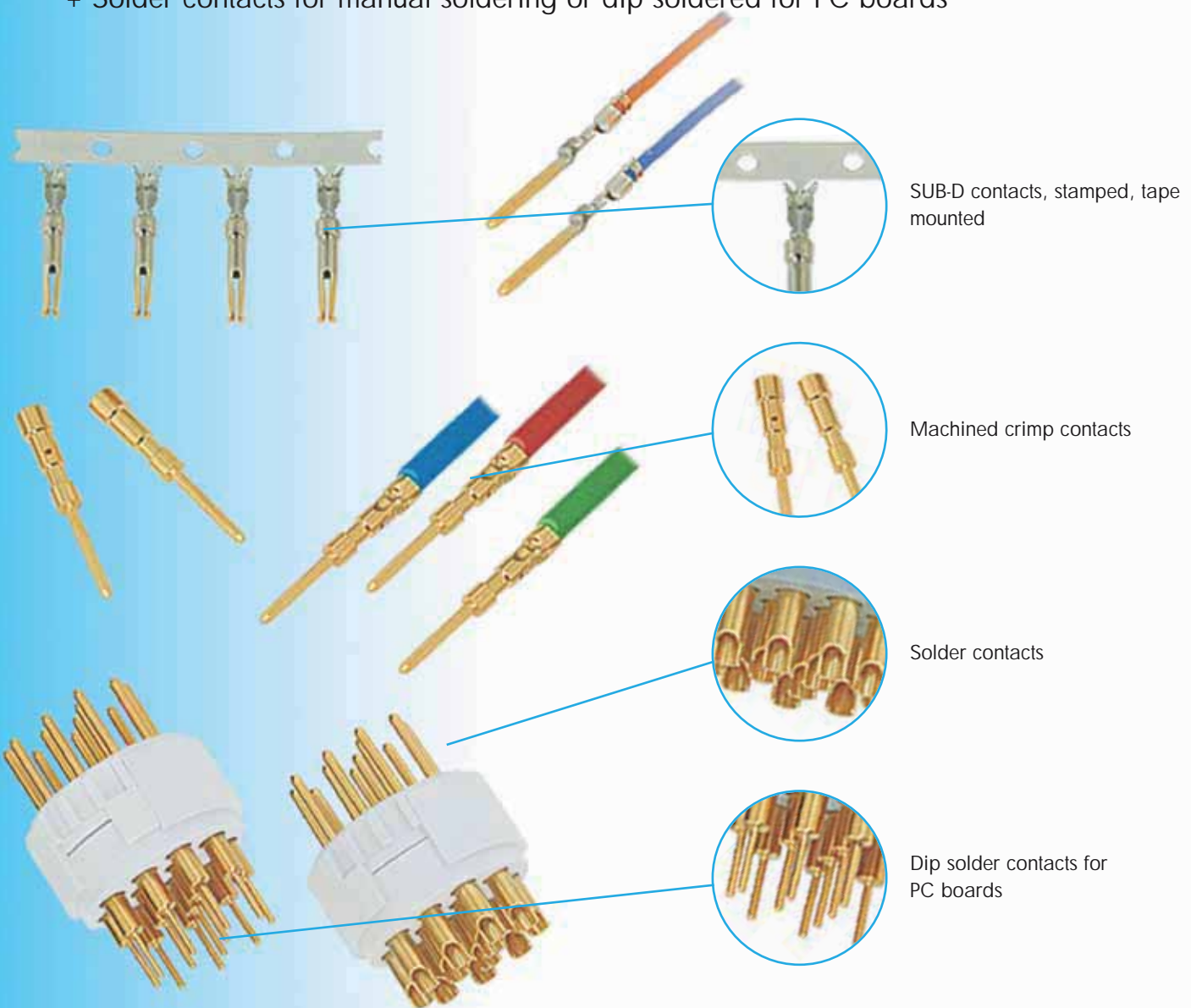

SUB-D contacts, stamped, tape mounted

Machined crimp contacts

Solder contacts

Dip solder contacts for PC boards

Setting the Standards	page 4
-----------------------	--------

Technical Information	page 14
-----------------------	---------

Connectors M 16	
page 15	

Connectors M 23 Profinet	
page 39	

Connectors M 23 RJ 45	
page 51	

Connectors Signal Size 1 M 23	
page 61	

Connectors Signal Size 1 M 27	
page 93	

Connectors Power Size 1 M 23	
page 103	

Connectors Power Size 1,5 M 40	
page 127	

Connectors Push-Pull Technology	
page 147	

Connectors Stainless Steel (INOX)	
page 157	

Connectors Moulded Cordsets	
page 165	

Custom Solutions	page 170
------------------	----------

Page Finder	page 174
-------------	----------

Distributors	page 175
--------------	----------

Technical Information

Nominal Current

Allowable current (Amp), that can be transmitted by each contact continuously and simultaneously.

Nominal Voltage

Allowable voltage (Volt), that can be applied to each contact continuously and simultaneously.

Test Voltage

Voltage which, under certain conditions, a connector can be exposed to without breakdown.

Degree of Protection

Potential dirt accumulation of a disconnected connector in a certain environment.

Degree of Protection 2

No permanent conductive dirt accumulation will occur. Temporary conductive dirt accumulation, such as condensation, is possible. Typical for households, offices, laboratories and test labs.

Degree of Protection 3

Conductive, as well as dry non-conductive dirt accumulation can occur. It can be temporarily conductive due to condensation. Typical for industrial and factory environments.

Additional remarks (pollution level)

If connectors being defined for pollution degree 1 and overvoltage category 1 are applied for other conditions (higher pollution degree and higher overvoltage category) voltages level reduce correspondingly. But the connectors can be used without any problems at reduced maximum voltages.

Mating cycles

Mating cycles are the number of insertion and extraction cycles a connector can withstand before the electrical or mechanical failure in relationship to the connector's design specification.

Air gap

The minimum gap of air between two conducting surfaces permissible at given voltage.

Creep distance

The minimum dimension along the surface of an insulating material between two conducting surfaces.

PE

The PE-Contact is a ground contact for security reasons.

Safety Guidelines

When Hummel connectors are used for voltages greater than 50 Volts with conductive shell components they must be used in accordance with the safety regulations DIN VDE Part 410; IEC 60364-4-41. This regulation basically dictates that the power source should be turned off before mating and unmating connector. This regulation does not provide protection against electrical shock when mating and unmating connectors in the field.



Don't connect or disconnect HUMMEL Connectors under load.

Connectors M 16



Housings

page 18



Inserts

page 22

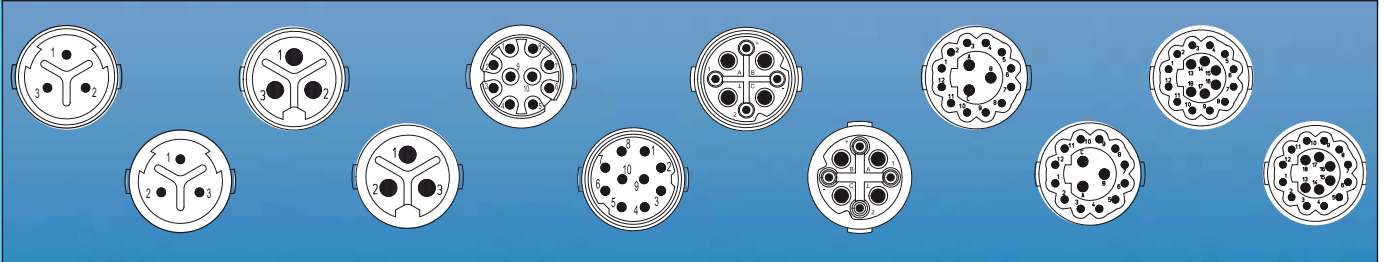

Accessories

page 28



M 16 Control Signal Connectors

Mechanical Data	Materials and Technical Data
Housing	Copper-Zinc alloy Die Casting Aluminium alloy
Housing surface	Nickel plated brass other surface upon request
Inserts (for contacts)	Thermoplastic Polyamid PA 6 (Nylon 6/6), PBT Fire protection class V-0
Contacts	Brass Alloy
Contact surface at point of contact	Nickel and gold plated (0,25µm Au)
Minimum mating cycles	> 1000
Seals / O-Rings	Buna-N standard, optional Viton® (Viton is a registered trademark of DuPont)
Temperature range	-40° C – 125° C (-40 °F – 257 °F)
Type of contacts	Crimp, solder, dip-solder (PCB)
Protection	IP 67 / IP 69K per EN 60529 (connected), NEMA 4x
Cable diameter range	2 – 11 mm (.08 – .43")

Electrical Data	3 (3 x 1 mm)		3 (3 x 2 mm)		4 + 3 + PE		10	12 + 3		18 ⁵⁾	
Number of positions	3		3		4		4	10	12	3	18
Number of contacts	3		3		4		4	10	12	3	18
Contact-Ø [mm]	1		2		0,8		1,6	1	0,8	1,25	0,8
AWG [mm ²]	0,14 – 1		0,5 – 2,5		0,08 – 0,34		0,34 – 1,5	0,14 – 0,75	0,08 – 0,34	0,5 – 1,5	0,08 – 0,34
Nominal current ¹⁾ [A]	8		20		5		16	8	3	10	3
Nominal voltage ²⁾ [V~] degree of protection 2 ⁴⁾	630		630		320		630	230	60	160	60
Nominal voltage ²⁾ [V~] degree of protection 3 ⁴⁾	400		400		160		320	160	24	60	24
Test voltage (Breakdown voltage) ³⁾ [V~]	2500		2500		1500		2500	1500	1500	2500	1500
Insulation resistance [MΩ]	> 10 ¹⁰		> 10 ¹⁰		> 10 ¹⁰		> 10 ¹⁰	> 10 ⁶	> 10 ¹⁰		> 10 ¹⁰
Max. contact resistance [mΩ]	3		3		3		3	3	3	3	3

^{1), 2), 3), 4)} See Technical Information page 14 ⁵⁾ Under development

Derating

Straight connectors male + female, 10 pole,
wires 10 x AWG 18

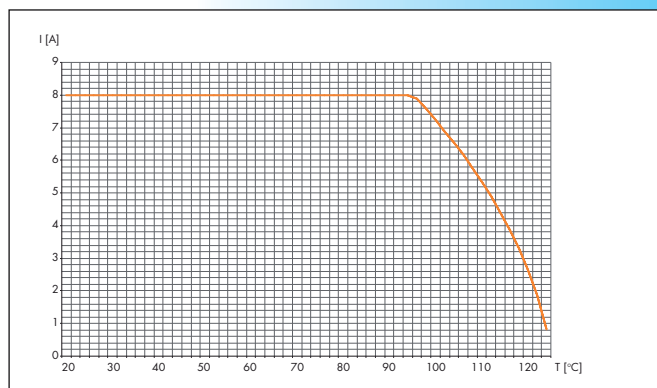

Connectors M 16 / Housing

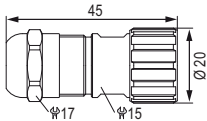
Straight Connector, Female Thread		Cable-Ø	Part Number
		2 – 7 mm (.08 – .28").....	7.810.300.000
		5 – 9 mm (.20 – .35").....	7.810.400.000
		Contacts and inserts page 22 • Assembly instructions page 32	

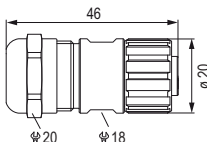
Straight Connector, Female Thread		Cable-Ø	Part Number
		8 – 11 mm (.31 – .43").....	7.810.5000.00
		Contacts and inserts page 22 • Assembly instructions page 32	

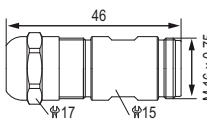
Straight Connector, Male Thread		Cable-Ø	Part Number
		2 – 7 mm (.08 – .28").....	7.820.300.000
		5 – 9 mm (.20 – .35").....	7.820.400.000
		Contacts and inserts page 22 • Assembly instructions page 32 / 33	

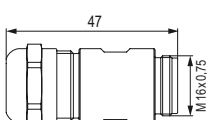
Straight Connector, Male Thread		Cable-Ø	Part Number
		8 – 11 mm (.31 – .43").....	7.820.5000.00
		Contacts and inserts page 22 • Assembly instructions page 32 / 33	

Cable-Ø	Part Number	Right Angle Connector, Female Thread
2 – 7 mm (.08 – .28")	7.830.300.000	
5 – 9 mm (.20 – .35")	7.830.400.000	
<p>Contacts and inserts page 22 • Assembly instructions page 34</p>		

Assembly tool 7.010.900.125 is required

Cable-Ø	Part Number	Right Angle Connector with positioning
2 – 7 mm (.08 – .28")	7.831.300.000	
5 – 9 mm (.20 – .35")	7.831.400.000	
<p>Contacts and inserts page 22 • Assembly instructions page 35</p>		

Cable-Ø	Part Number	Panel Connector with built in Cable Strain Relief
<p>Rear mounting, single hole mounted</p>		
2 – 7 mm (.08 – .28")	7.852.300.000	
5 – 9 mm (.20 – .35")	7.852.400.000	
<p>Including jam nut</p>		
<p>Contacts and inserts page 22 • Assembly instructions page 32</p>		

Cable-Ø	Part Number	Panel Connector with built in Cable Strain Relief
<p>Rear mounting, M2,5 x 4 single hole mounted</p>		
2 – 7 mm (.08 – .28")	7.847.300.000	
5 – 9 mm (.20 – .35")	7.847.400.000	
<p>Contacts and inserts page 22 • Assembly instructions page 32</p>		



Connectors M 16 / Housing



Panel Connector, Male Thread, Front Mounting		Type	Part Number
		4 x holes \varnothing 2,7 mm (.11") ..7.840.000.000	Flange 20 x 20 mm
		4 x holes \varnothing 2,7 mm.....7.840.100.000	Flange 25 x 25 mm
		Contacts and inserts page 22 • Assembly instructions page 36	

Panel Connector, Male Thread, Front Mounting		Type	Part Number
		Short version	4 x holes \varnothing 2,7 mm (.11") ..7.840.200.000
			Flange 20 x 20 mm
		Contacts and inserts page 22 • Assembly instructions page 36	

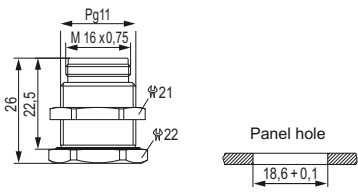

Right Angle Panel Connector, Male Thread		Type	Part Number
		300° rotating, locking screw at flange	4 x holes \varnothing 2,7 mm (.11") ..7.843.000.000
			Flange 20 x 20 mm
			4 x holes \varnothing 2,7 mm.....7.843.100.000
			Flange 25 x 25 mm
		Contacts and inserts page 22 • Assembly instructions page 37	

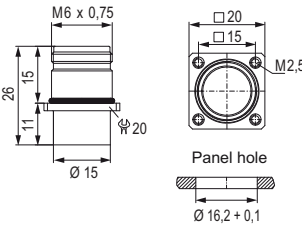
Panel Connector, Male Thread		Type	Part Number
		Front mounting, single hole mounted	Thread M 16 x 1,57.842.000.000



Type	Part Number	Panel Connector, Male Thread
Rear mounting, single hole mounted Including jam nut.....7.850.000.000		
Contacts and inserts page 22 • Assembly instructions page 36		

Type	Part Number	Panel Connector, Male Thread
Rear mounting, 4 x thread M2,5 Flange 20 x 20 mm7.845.000.000		
Contacts and inserts page 22 • Assembly instructions page 36		

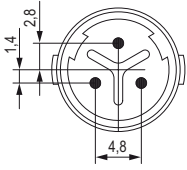
Connectors M 16 / Inserts / Pinouts

Inserts 3-pole (3 x 1)	Type	Part Number	Part Number
 <p>Insert pin mating view</p>	Insert	Pins	Sockets
	without contacts	7.003.903.101	7.003.903.102
 <p>Insert socket mating view</p>	Insert with dip solder contacts		
	Length 10 mm	7.001.903.127	7.001.903.108
	Insert with dip solder contacts		
	Length 17 mm ¹⁾	7.001.903.137	7.001.903.118
	Required Contacts		
	3 x 1 mm	7.010.901.001	7.010.901.002 / 7.010.901.012
	Contacts page 26		

¹⁾ Under development

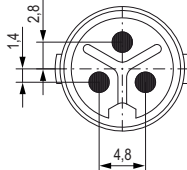
Inserts 3-pole (3 x 2)	Type	Part Number	Part Number
 <p>Insert pin mating view</p>	Insert	Pins	Sockets
	without contacts	7.003.983.101	7.003.983.102
 <p>Insert socket mating view</p>	Insert with dip solder contacts		
	Length 10 mm ¹⁾	7.001.983.127	7.001.983.108
	Insert with dip solder contacts		
	Length 17 mm ¹⁾	7.001.983.137	7.001.983.118
	Required Contacts		
	3 x 2 mm	7.010.982.001	7.010.982.002
	Contacts page 27		

¹⁾ Under development

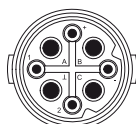
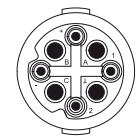
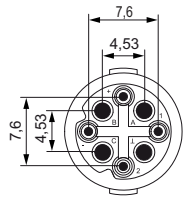
Type	Part Number	Part Number	Inserts 4+3+PE
	Pins	Sockets	
Insert without contacts	7.003.943.101	7.003.943.102	 <p>Insert pin mating view</p>
Insert with dip solder contacts Length 10 mm ¹⁾	7.001.943.127	7.001.943.108	
Insert with dip solder contacts Length 17 mm ¹⁾	7.001.943.137	7.001.943.118	
Required Contacts			 <p>Insert socket mating view</p>
4 x 0,8 mm	7.010.980.801	7.010.980.802	
4 x 1,6 mm	7.010.981.601	7.010.981.602	
Contacts page 26			

¹⁾ Under development

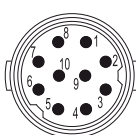
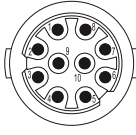
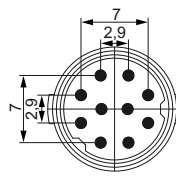
Type	Part Number	Part Number	Inserts 10-pole
	Pins	Sockets	
Insert without contacts	7.003.910.101	7.003.910.102	 <p>Insert pin mating view</p>
Insert with dip solder contacts Length 10 mm	7.001.910.127	7.001.910.108	
Insert with dip solder contacts Length 17 mm ¹⁾	7.001.910.137	7.001.910.118	
Required Contacts			 <p>Insert socket mating view</p>
10 x 1 mm	7.010.981.001	7.010.981.002	
Contacts page 26			
Contacts page 26			

¹⁾ Under development

Connectors M 16 / Inserts / Pinouts

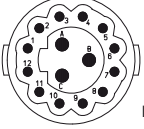
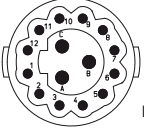
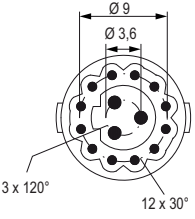
Inserts 12+3-pole	Type	Part Number	Part Number
		Pins	Sockets
 <p>Insert pin mating view</p>	Insert without contacts	7.003.985.101	7.003.985.102
	Insert with dip solder contacts Length 10 mm	7.001.985.127	7.001.985.108
 <p>Insert socket mating view</p>	Insert with dip solder contacts Length 17 mm	7.001.985.137	7.001.985.118
	 <p>3 x 120° 12 x 30°</p>		

Contacts page 26

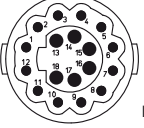
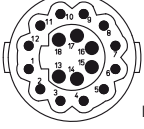
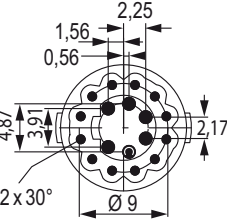
Inserts 18-pole ¹⁾	Type	Part Number	Part Number
		Pins	Sockets
 <p>Insert pin mating view</p>	Insert without contacts ¹⁾	7.003.988.101	7.003.988.102
	Insert with dip solder contacts Length 10 mm ¹⁾	7.001.988.127	7.001.988.108
 <p>Insert socket mating view</p>	Insert with dip solder contacts Length 17 mm ¹⁾	7.001.988.137	7.001.988.118
	 <p>12 x 30°</p>		









Contacts page 26

¹⁾ Under development



Connectors M 16 / Required Contacts

Number of Poles	Required Contacts	Type	Part Number	Contact Arrangement
3 (3 x 1)	3 x 1 mm	Pins..... Sockets.....	7.010.901.001 7.010.901.002	
3 (3 x 2)	3 x 2 mm	Pins..... Sockets.....	7.010.982.001 7.020.982.002	
4 + 3 + PE	4 x 0,8 mm 4 x 1,6 mm	Pins..... Sockets..... Pins..... Sockets.....	7.010.980.801 7.010.980.802 7.010.981.601 7.010.981.602	
10	10 x 1 mm	Pins..... Sockets.....	7.010.981.001 7.010.981.002	
15 (12 + 3)	12 x 0,8 mm 3 x 1,25 mm	Pins..... Sockets..... Pins..... Sockets.....	7.010.980.801 7.010.980.802 7.010.981.201 7.010.981.202	
18	18 x 0,8 mm	Pins..... Sockets.....	7.010.980.801 7.010.980.802	





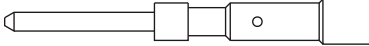
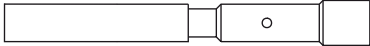

Crimp contacts page 26 / 27

Contacts	Type	Crimp Range	Part Number
	Crimp pin 0,8 mm, machined.....	0,08 – 0,34 mm ² (AWG 28 – 22) ..	7.010.980.801
	Crimp socket 0,8 mm, machined.....	0,08 – 0,34 mm ² (AWG 28 – 22) ..	7.010.980.802
	Crimp pin 1 mm, machined.....	0,14 – 0,75 mm ² (AWG 26 – 18) ..	7.010.981.001
	Crimp socket 1 mm, machined.....	0,14 – 0,75 mm ² (AWG 26 – 18) ..	7.010.981.002
	Crimp pin 1 mm, machined.....	0,14 – 1 mm ² (AWG 26 – 17) ..	7.010.901.001
	Crimp socket 1 mm, machined.....	0,08 – 0,56 mm ² (AWG 28 – 20) ..	7.010.901.012
	Crimp socket 1 mm, machined.....	0,34 – 1 mm ² (AWG 22 – 17) ..	7.010.901.002
	Crimp pin 1,25 mm, machined.....	0,5 – 1,5 mm ² ..	7.010.981.201
	Crimp socket 1,25 mm, machined.....	0,5 – 1,5 mm ² ..	7.010.981.202

Please see assembly instructions on page 34

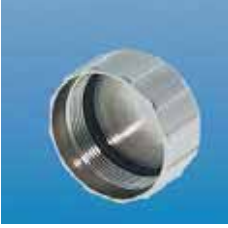
Type	Crimp Range	Part Number	Contacts
Crimp pin 1,6 mm, machined	0,34 – 1,5 mm ² (AWG 22 – 16) ..	7.010.981.601	
Crimp socket 1,6 mm, machined	0,34 – 1,5 mm ² (AWG 22 – 16) ..	7.010.981.602	
Crimp pin 2 mm, machined	1,0 – 2,5 mm ²	7.010.982.001	
Crimp socket 2 mm, machined	1,0 – 2,5 mm ²	7.010.982.002	

Please see assembly instructions on page 34

Accessories	Type	Part Number
	Plastic protective cap for connectors with male thread for connectors with female thread	7.000.980.161 7.000.980.162
	Brass protective cap for connectors with female thread	7.010.900.163
	Brass protective cap for connectors with male thread	7.010.900.162
	Brass protective cap with chain for connectors with female threadLength 70 mm	7.010.9S0.705
	Brass protective cap with chain for connectors with male threadLength 70 mm	7.010.9S0.704
	Assembly tool for Right Angle Connector M 16	7.010.900.125

Please see assembly instructions on page 34

Crimp tool for manual crimping
of machined crimp contacts
for signal connectors M 16 and M 23 7.000.900.904



See page 82 for crimp tool instructions

Adaptor flange
for Straight Connectors 7.010.900.135

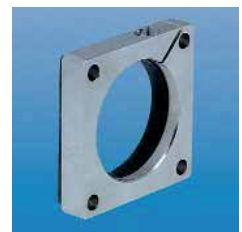

Conduit adaptor	DN 10	7.010.900.200
	Snapflex 16.....	7.010.900.201
	DN 12	7.010.900.202
	Snapflex 16.....	7.010.900.203



Crimp Tool for Connectors M 16

Crimp Tool Setting for HUMMEL Crimp Contacts (Crimp Tool 7.000.900.904)

Part Number	Crimp Contact	Cross Section (mm ²)	AWG	Crimp Tool Setting mm	Locator Setting
7.010.980.801	Crimp pin 0,8 mm	0,08	AWG 28	0,57	10
		0,14	AWG 26	0,60	
		0,25	AWG 24	0,64	
		0,34	AWG 22	0,73	
7.010.980.802	Crimp socket 0,8 mm	0,08	AWG 28	0,57	10
		0,14	AWG 26	0,60	
		0,25	AWG 24	0,64	
		0,34	AWG 22	0,73	
7.010.981.001	Crimp pin 1 mm	0,08	AWG 28	0,60	7
		0,14	AWG 26	0,65	
		0,25	AWG 24	0,67	
		0,34	AWG 22	0,71	
		0,56	AWG 20	0,75	
		0,75	AWG 18	0,82	
7.010.981.002	Crimp socket 1 mm	0,08	AWG 28	0,60	8
		0,14	AWG 26	0,63	
		0,25	AWG 24	0,66	
		0,34	AWG 22	0,69	
		0,56	AWG 20	0,75	
		0,75	AWG 18	0,83	
7.010.901.001	Crimp pin 1 mm	0,14	AWG 26	0,86	1
		0,25	AWG 24	0,90	
		0,34	AWG 22	0,95	
		0,56	AWG 20	0,98	
		0,75	AWG 18	1,03	
		1,0	AWG 17	1,08	
7.010.901.012	Crimp socket 1 mm (0,08-0,56 mm ²)	0,08	AWG 28	0,75	2
		0,14	AWG 26	0,78	
		0,25	AWG 24	0,82	
		0,34	AWG 22	0,86	
		0,56	AWG 20	0,90	
7.010.901.002	Crimp socket 1 mm (0,34 – 1 mm ²)	0,34	AWG 22	0,77	2
		0,56	AWG 20	0,82	
		0,75	AWG 18	0,88	
		1,0	AWG 17	0,95	

These values are only guidelines and actual conductor cross sections depend on manufacturer tolerances.

See page 38 for crimp tool instructions

Crimp Tool for Connectors M 16

Crimp Tool Setting for HUMMEL Crimp Contacts (Crimp Tool 7.000.900.904)

Part Number	Crimp Contact	Cross Section (mm ²)	AWG	Crimp Tool Setting mm	Locator Setting
7.010.981.201	Crimp pin 1,25 mm	0,5	AWG 20	0,70	2
		0,75	AWG 18	0,73	
		1,0	AWG 17	0,79	
		1,5	AWG 16	0,88	
7.010.981.202	Crimp socket 1,25 mm	0,5	AWG 20	0,70	2
		0,75	AWG 18	0,73	
		1,0	AWG 17	0,79	
		1,5	AWG 16	0,88	
7.010.981.601	Crimp pin 1,6 mm	0,34	AWG 22	0,80	6
		0,56	AWG 20	0,84	
		0,75	AWG 18	0,90	
		1,0	AWG 17	1,00	
		1,5	AWG 16	1,10	
7.010.981.602	Crimp socket 1,6 mm	0,34	AWG 22	0,83	9
		0,56	AWG 20	0,90	
		0,75	AWG 18	0,97	
		1,0	AWG 17	1,02	
		1,5	AWG 16	1,10	
7.010.982.002	Crimp socket 2 mm	1,0	AWG 17	1,35	4
		1,5	AWG 16	1,45	
		2,5	AWG 14	1,60	
7.010.982.001	Crimp pin 2 mm	1,0	AWG 17	1,35	5
		1,5	AWG 16	1,45	
		2,5	AWG 14	1,60	

These values are only guidelines and actual conductor cross sections depend on manufacturer tolerances.

See page 38 for crimp tool instructions

Female Threaded Connector / Male Threaded Connector

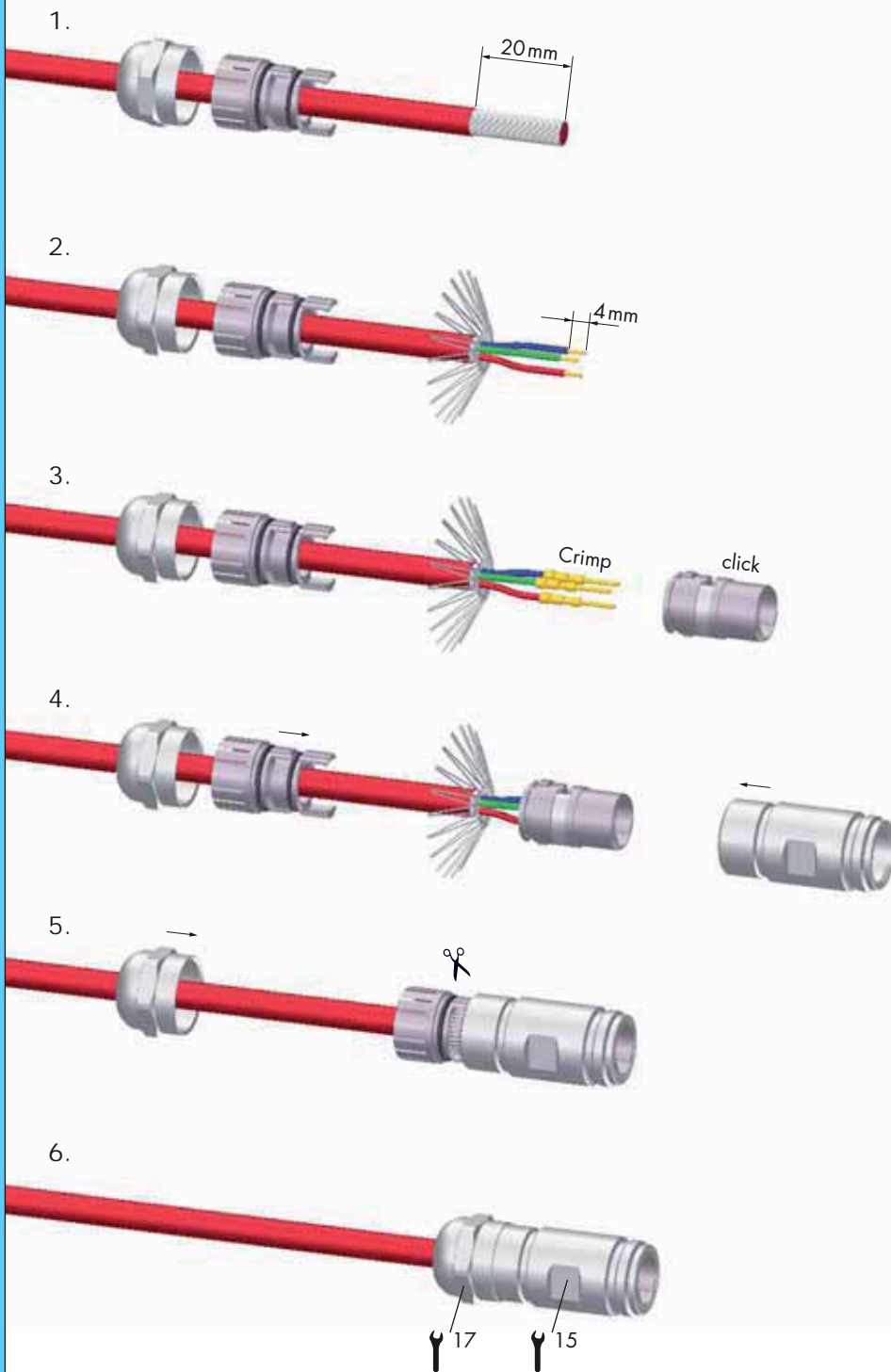

Male Threaded Connector 12 + 3

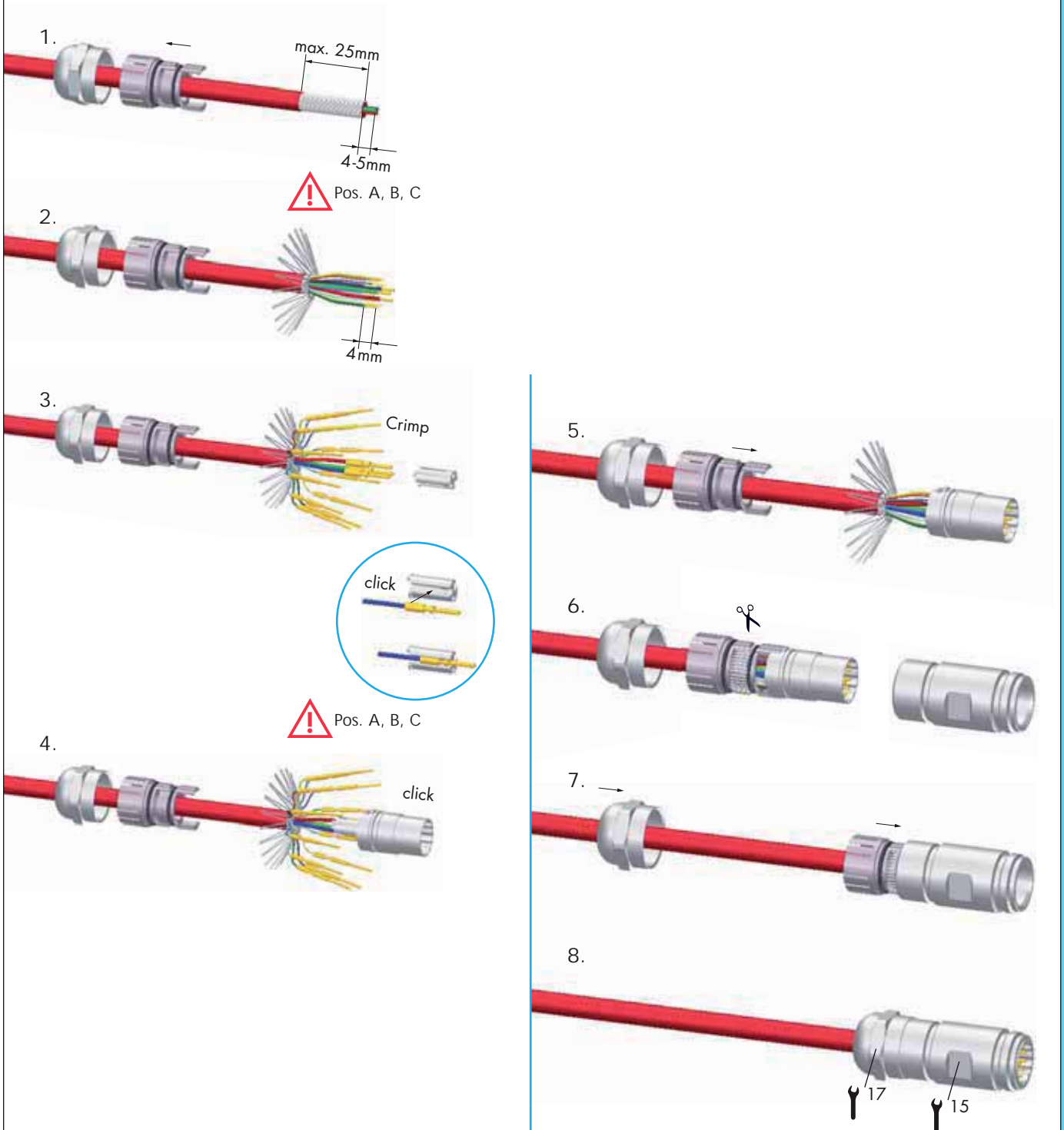

Right Angle Connectors

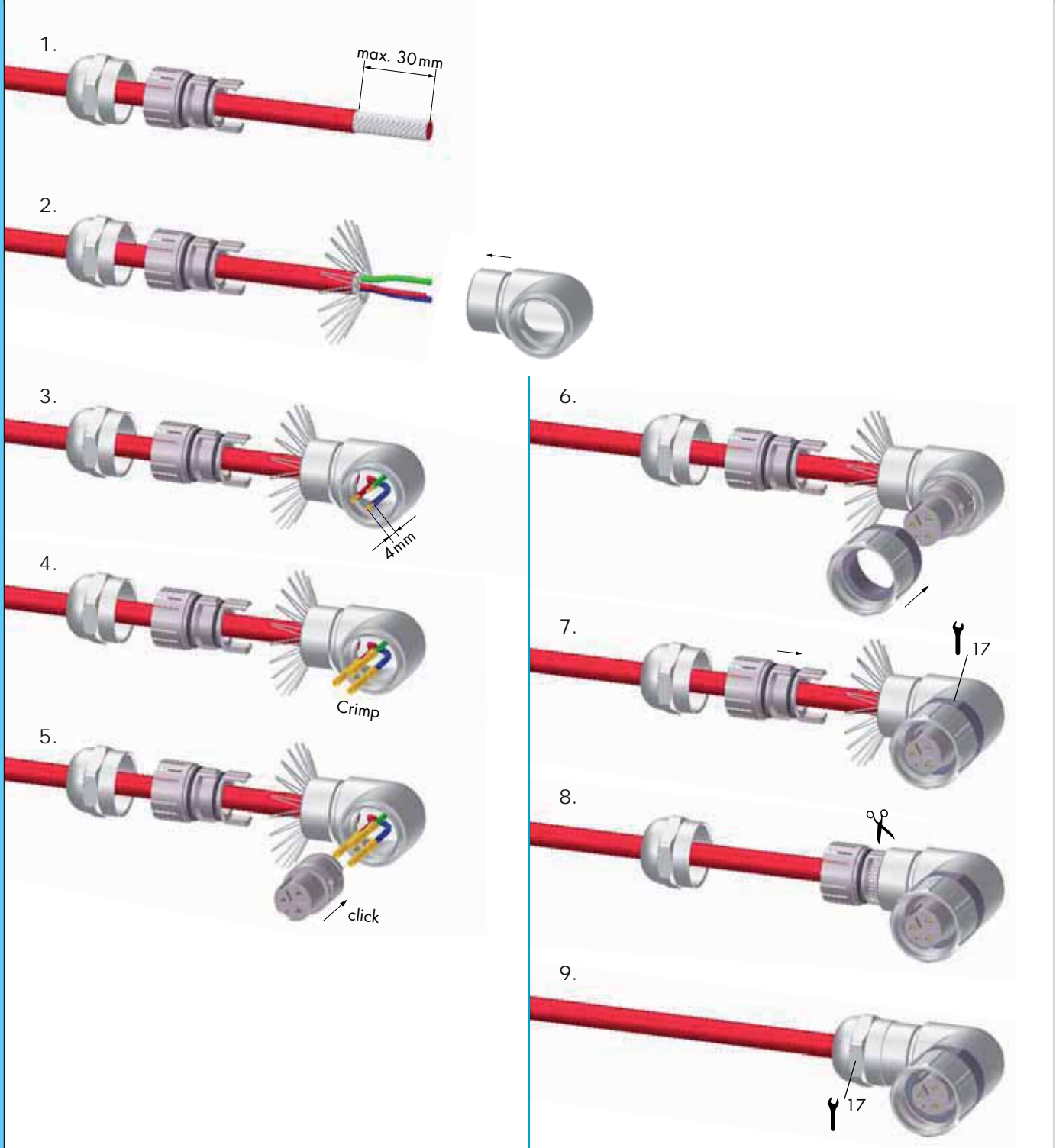

Right angle connector with positioning

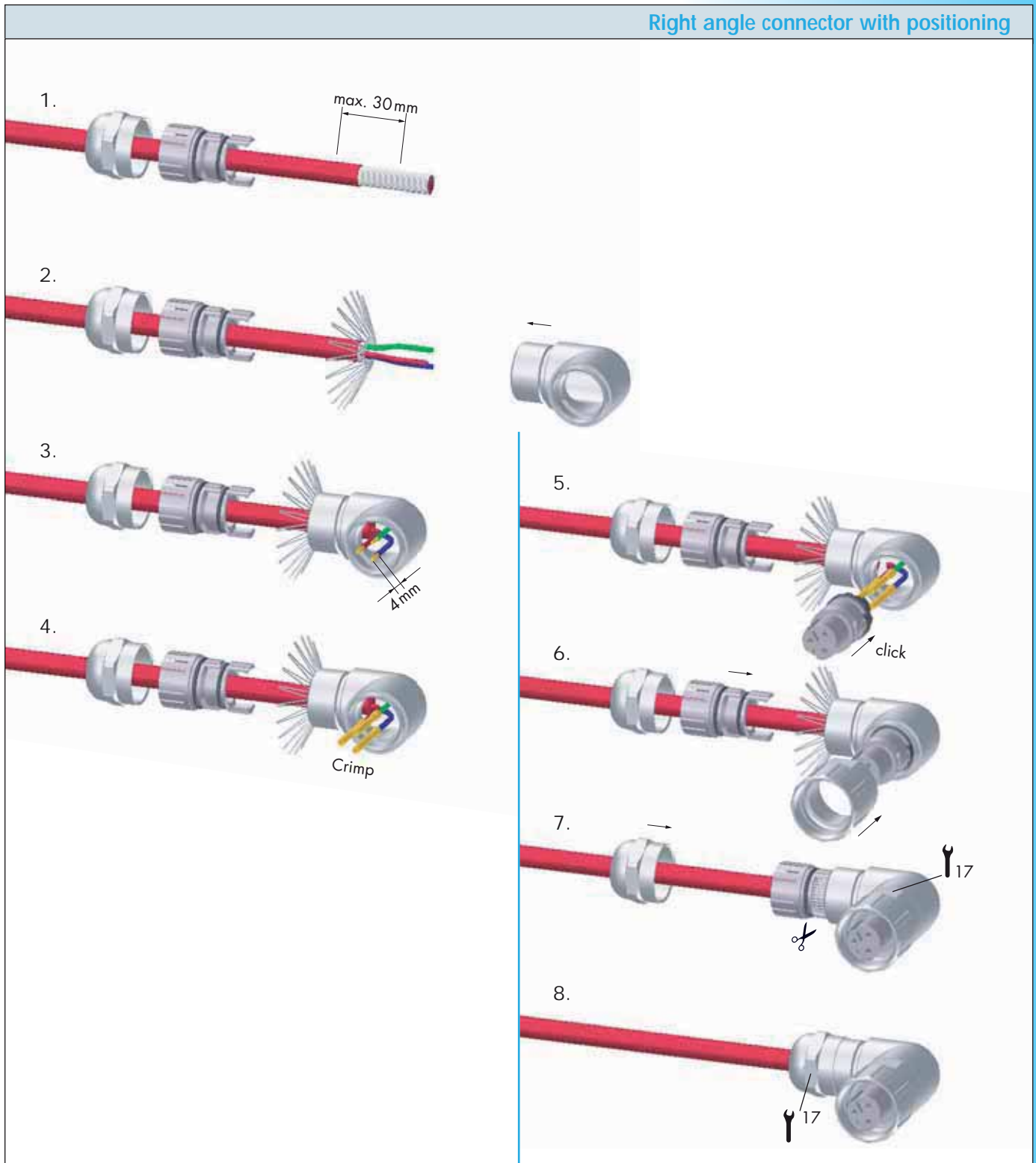

Panel Connector

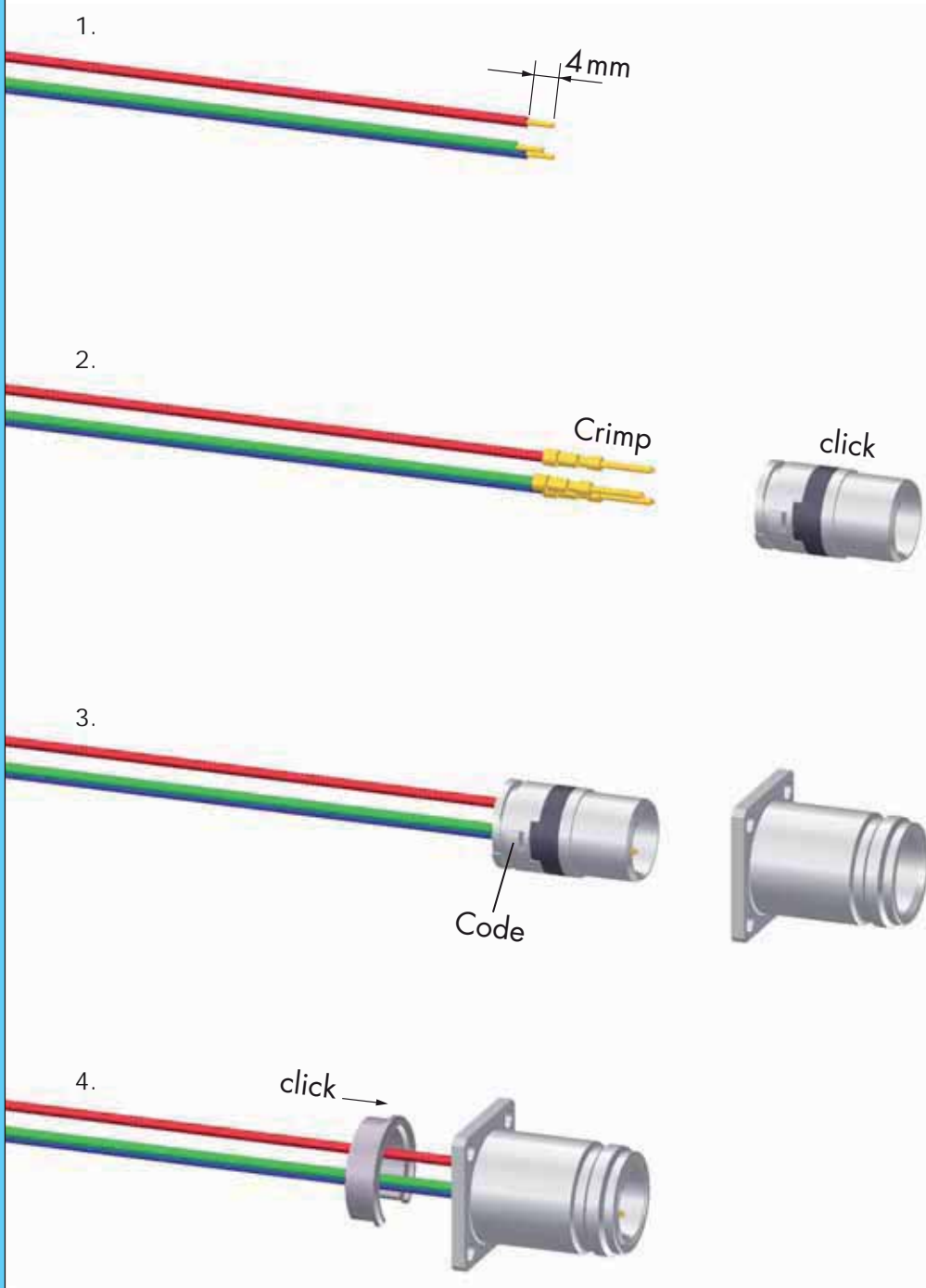

Right Angle Panel Connector

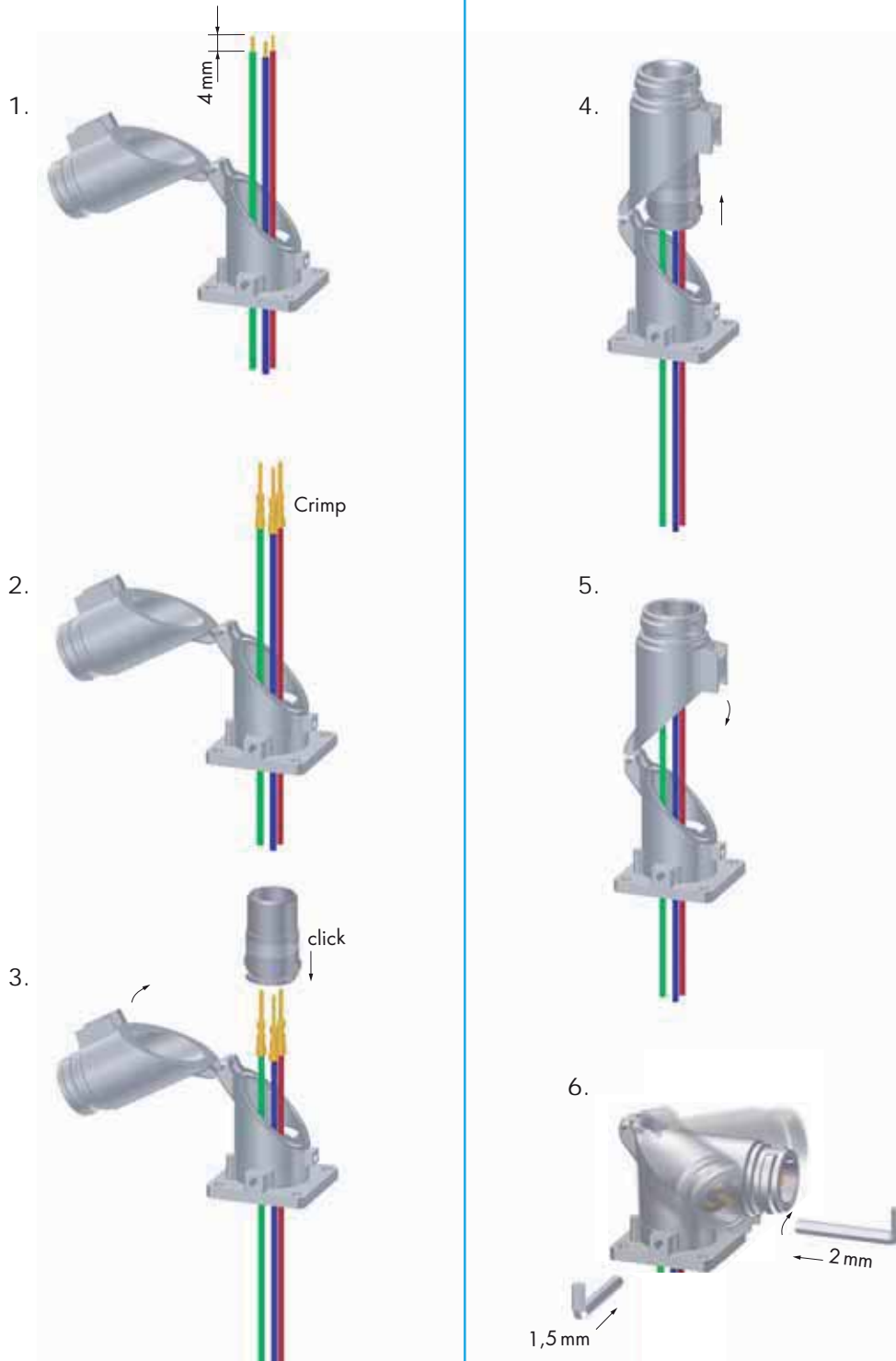

Crimping, Assembly and Disassembly of Contacts

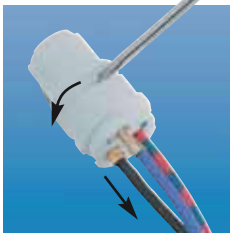

Crimping

- Remove conductor insulation 4 mm (.16") max.
- Select appropriate Crimp tool setting (see page 30 - 31)
- Push crimp contact into opening of crimping tool
- Insert stripped wire into the funnel shaped end of the crimp contact
- Squeeze handles of crimping tool together connect contact to wire

Assembly

- Remove crimped assembly and pull on wire to test connection
- Push into desired position of insert

Disassembly of Contacts from Insert

A small screwdriver is needed to remove the contacts from the insert.

- Release the white ring by a screwdriver out of the insert
- Move the misplaced contacts out of the insert
- Enter the ring back into the insert
- Push the contacts back into insert

Shielding

- Assemble strain relief insert with insert
- Fold stranding of the shield back over the first O-Ring of the strain relief insert
- Cut back the overextending braid



The stranding of the shield is not allowed to touch the second O-Ring. Otherwise the assembly may not be proof.

M 23 Profinet Connectors



Housings

page 42



Inserts

page 44



Accessories

page 49







M 23 Profinet Connectors

Mechanical Data	Materials and Technical Data
Housing	Copper-Zinc alloy Die Casting
Housing surface	Nickel plated brass
Inserts (for contacts)	PBT UL-94 V0, PA6
Contacts	Brass Alloy
Contact surface at point of contact	Nickel and gold plated (0,25µm Au)
Minimum mating cycles	> 1000
Seals / O-Rings	Perbunan NBR (Standard)
Temperature range	-40° C – 125° C (-40 °F – 257 °F)
Type of contacts	Crimp, dip-solder (PCB)
Protection	IP 67 per EN 60529 (connected), NEMA 4x
Cable diameter range	11 – 17 mm (.43" – .67")

Electrical Data		
Number of positions	20 (4 x 2 + 12)	
Number of contacts	4 x 2	12
Contact-Ø [mm]	0,6	1
AWG [mm ²]	0,08 – 0,34	0,14 – 1 / 1,5
Nominal current ¹⁾ [A]	2	8 ¹⁾
Nominal voltage ²⁾ [V~] degree of protection 2 ⁴⁾	160	320
Nominal voltage ²⁾ [V~] degree of protection 3 ⁴⁾	60	160
Test voltage (Breakdown voltage) ³⁾ [V~]	500	1500
Insulation resistance [MΩ]	> 10 ⁶	> 10 ⁶
Max. contact resistance [mΩ]	3	3
Impedance [Ω] (at 100MHz)	100	-

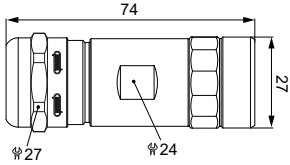
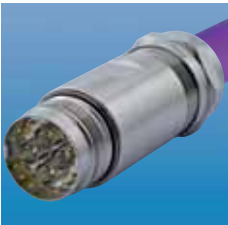
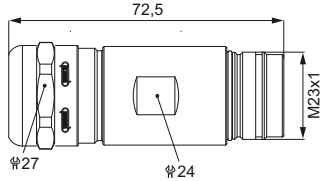
¹⁾, ²⁾, ³⁾, ⁴⁾ See Technical Information page 14 ¹⁾ for single contacts even 10 A possible

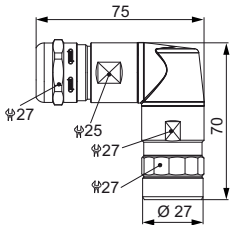

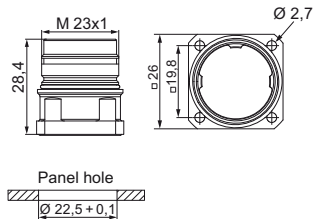
M 23 Profinet Connectors / Housing

Straight Female Connector		Cable-Ø	Part Number
		11-17 mm (.43 – .67")7.108.600.000
		Inserts page 44 • Assembly instructions page 46	
Straight Connector, Male Thread		Cable-Ø	Part Number
		11-17 mm (.43 – .67")7.208.600.000
		Inserts page 44 • Assembly instructions page 46	
Right Angle Connector, Female Thread		Type	Part Number
		11-17 mm (.43 – .67")7.308.600.000
		Inserts page 44 • Assembly instructions page 48	
Panel Connector, Male Thread, Front Mounting		Type	Part Number
		4 x holes Ø 2,7 mm (.11")	..7.408.000.000
		Flange 26 x 26 mm	
		Inserts page 44 • Assembly instructions page 47	

Type	Part Number	Panel Connector, Rear Mounting
<p>4 x holes \varnothing 2,7 mm (.11") ..7.468.000.000 Flange 26 x 26 mm</p>	<p>Technical drawing showing dimensions: M23x1, 27.7, \varnothing 26, \varnothing 20.5, \varnothing 2.7, and Panel hole \varnothing 23.1+0.1.</p>	
<p>Inserts page 44 • Assembly instructions page 47</p>		

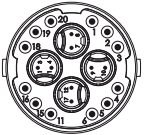
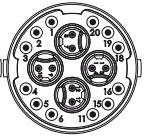
M 23 Profinet Connectors / Inserts / Pinouts / Contacts

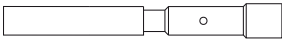
Inserts (4 x 2) + 12	Type	Part Number	Part Number
 <p>Insert pin mating view</p>		Pins	Sockets
	Insert		
	without contacts	7.003.920.101	7.003.920.102
	Insert with dip solder contacts	7.001.920.107	7.001.920.108
 <p>Insert socket mating view</p>	Required Contacts		
	8 x 0,6	7.010.980.641	7.010.980.602
	12 x 1	7.010.901.045	7.010.901.002
		7.010.901.049	7.010.901.012
			7.010.901.022
			7.010.901.046

Contacts	Type	Part Number	Part Number
	Crimp pin 0,6 mm, machined....	0,08 – 0,34 mm ²	7.010.980.641
	Crimp socket 0,6 mm, machined....	0,08 – 0,34 mm ²	7.010.980.602
	Crimp pin 1 mm, machined.....	0,14 – 1 mm ²	7.010.901.049
		0,75 – 1,5 mm ²	7.010.901.045
	Crimp socket 1 mm, machined...	0,14 – 0,56 mm ²	7.010.901.012
		0,34 – 1 mm ²	7.010.901.002
		0,75 – 1,5 mm ²	7.010.901.022
		1 – 1,75 mm ²	7.010.901.046

Please see assembly instructions on page 45

Crimp Tool Settings for Connectors M 23 Profinet

Crimp Tool Settings for HUMMEL Crimp Contacts (Crimp Tool 7.000.900.907)

Part Number	Crimp Contact	Cross Section (mm ²)	AWG	Crimp Tool Setting mm	Locator Setting
7.010.980.641	Crimp pin 0,6 mm (0,08 – 0,34 mm ²)	0,08	AWG 28	0,71	B 1
		0,14	AWG 26	0,75	
		0,25	AWG 24	0,80	
		0,34	AWG 22	0,88	
7.010.980.602	Crimp socket 0,6 mm (0,08 – 0,34 mm ²)	0,08	AWG 28	0,71	B 2
		0,14	AWG 26	0,75	
		0,25	AWG 24	0,80	
		0,34	AWG 22	0,88	
7.010.901.049	Crimp pin 1 mm (0,14 – 1,0 mm ²)	0,14	AWG 26	0,86	B 3
		0,25	AWG 24	0,90	
		0,34	AWG 22	0,95	
		0,56	AWG 20	0,98	
		0,75	AWG 18	1,03	
		1,00	AWG 17	1,08	
7.010.901.045	Crimp pin 1 mm (0,75 – 1,5 mm ²)	0,75	AWG 18	1,13	B 3
		1,00	AWG 17	1,20	
		1,50	AWG 16	1,28	
7.010.901.012	Crimp socket 1 mm (0,08 – 0,56 mm ²)	0,08	AWG 28	0,75	B 4
		0,14	AWG 26	0,78	
		0,25	AWG 24	0,82	
		0,34	AWG 22	0,88	
		0,56	AWG 20	0,90	
7.010.901.002	Crimp socket 1 mm (0,34 – 1,0 mm ²)	0,34	AWG 22	0,77	B 4
		0,56	AWG 20	0,82	
		0,75	AWG 18	0,88	
		1,00	AWG 17	0,95	
7.010.901.022	Crimp socket 1 mm (0,75 – 1,5 mm ²)	0,75	AWG 18	1,13	B 4
		1,00	AWG 17	1,20	
		1,50	AWG 16	1,28	
7.010.901.046	Crimp socket 1 mm (1 – 1,75 mm ²)	1,00	AWG 17	1,25	B 4
		1,50	AWG 16	1,33	
		1,75	AWG 15	1,38	

These values are only guidelines and actual conductor cross sections depend on manufacturer tolerances.

M23 Profinet Connectors / Assembly Instructions

Straight Connector Male / Female Thread



x Pins = 41 mm
Sockets = 37 mm



y Pins = 7 mm
Sockets = 0 mm

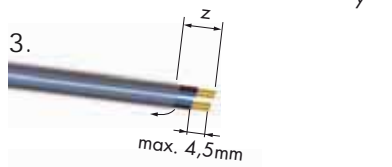

z Pins = 10 mm
Sockets = 7 mm

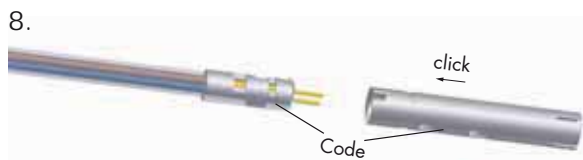
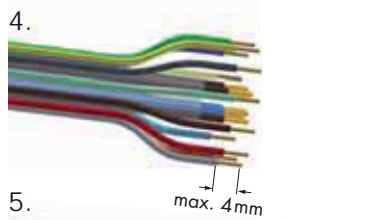

7.000.900.906

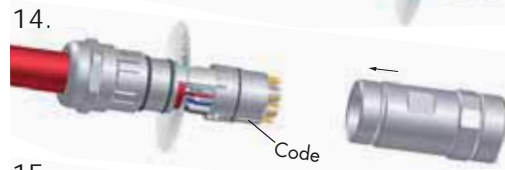
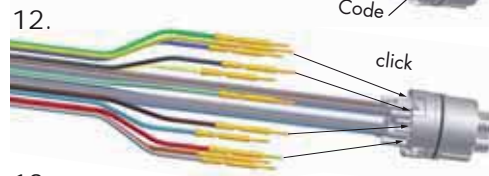
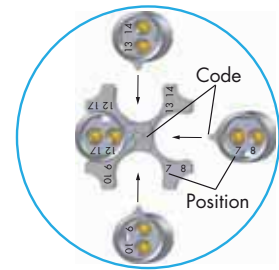
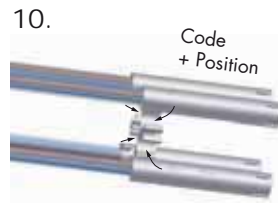

M 23 Profinet Connectors / Assembly Instructions

Panel Connector

1.

x	Pins = 10 mm Sockets = 7 mm
---	--------------------------------

2.

3.

4.

5.

6.

7.

8.

9.

10.

11.

12.

M 23 Profinet Connectors / Assembly Instructions

Right Angle Connector

1. 80mm, 55mm

2.

3. x Pins = 7 mm
Sockets = 0 mm
max. 4,5mm

4. y Pins = 10 mm
Sockets = 7 mm
max. 4mm

5. Crimp

6. Crimp

7. click

8. click
Code

9. Crimp
7.000.900.906

10. Code + Position

11. Code

12. Code

13. click

14. Code

15. 27



16. 27

17. 27, 24

M 23 Profinet Connectors / Accessories

Type	Part Number	Accessories	
Plastic protective cap for connectors with male thread	7.000.900.101		
for connectors with female thread.....	7.000.900.102		
Brass protective cap for connectors with female thread.....	7.010.900.183		
Brass protective cap with chain for connectors with female thread			
.....Length 70 mm	7.010.9S0.783		
.....Length 100 mm	7.010.9S1.083		
Brass protective cap for connectors with male thread	7.010.900.102		
Brass protective cap with chain for connectors with male thread			
.....Length 70 mm	7.010.9S0.702		
.....Length 100 mm	7.010.9S1.002		
Conduit adaptor	Snapflex 16..... 7.010.900.204		
	DN 12		7.010.900.205
	Snapflex 20..... 7.010.900.206		
	DN 14		7.010.900.207
	Snapflex 25..... 7.010.900.208		
	DN 17		7.010.900.209
Adaptor flange for Straight Connectors	7.010.900.128		

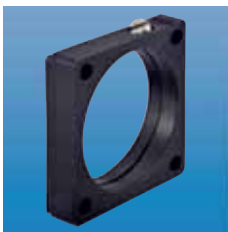
M 23 Profinet Connectors / Accessories

Accessories	Type	Part Number
	Adapter flange for moulded connectors (non-conductive surface)	7.010.900.139
	Multi-Bus adapter wired through I:I (excentric)	
	Control Cabinet adapter for Multibus II - AIDA	
	I/O adapter module to scan or feed signals	
	Manual Crimp tool for EMC sleeves M 23 Profinet	7.000.900.906
	Manual Crimp tool for turned contacts M 23 Profinet	7.000.900.907

Connectors M 23 RJ 45



Housings

page 54



Accessories

page 57

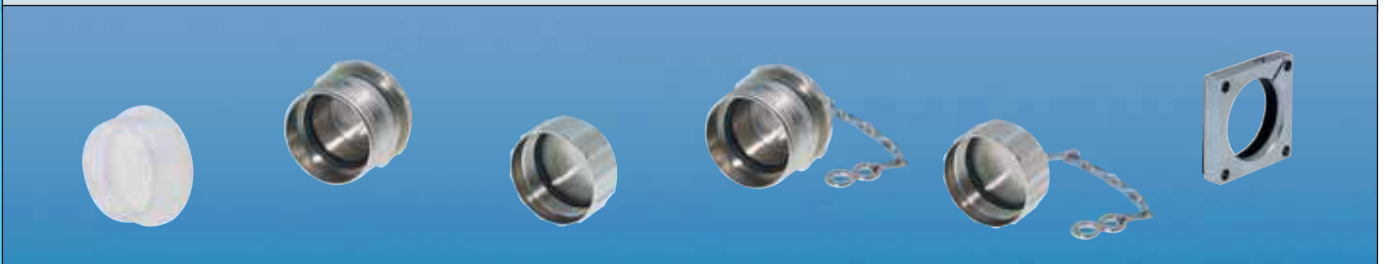



M 23 RJ 45 Control Signal Connectors

Technical Data	M 23 RJ 45
Housing	Brass Alloy, Die Cast
Housing Surface	Nickel Plated
Inserts (for contacts)	PBT UL-94 V0, PA 6
Contacts	Brass Alloy
Contact Surface at point of contact	Depends on RJ 45 type used
Seals / O-Rings	NBR / FKM (Viton)
Temperature Range	Depends on RJ 45 type used
Degree of Protection	IP 67 / IP 69 K per EN 60529 (mated)
Cable diameter range	3 - 7 / 7 - 12 / 11 - 17mm
Number of Positions	4 / 6 / 8-pos, optional 4 + 2 / 6 + 2 / 8 + 2
Nominal Current ¹⁾ [A]	Depends on RJ 45 type used
Nominal Voltage ²⁾ [V~]	Depends on RJ 45 type used
Test Voltage [V~]	Depends on RJ 45 type used
Insulation Resistance [MΩ]	Depends on RJ 45 type used
Max. Crossover Resistance [mΩ]	Depends on RJ 45 type used
Max. Data Rate	Depends on RJ 45 type used

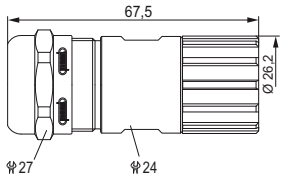
Connectors M 23 RJ 45 / Housing

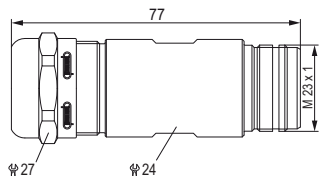
Straight Connector Female Thread		Cable-Ø	Part Number
		3 – 7 mm (.12 - .28")	7.R10.400.000
		Connector with insert for patch cable	
		Suitable patch cable can be recommended	
Assembly instructions page 59			

Straight Connector Male Thread		Cable-Ø	Part Number
		3 – 7 mm (.12 - .28")	7.R20.408.000
		Incl. 8-pos coupler, fully occupied	
Assembly instructions page 60			

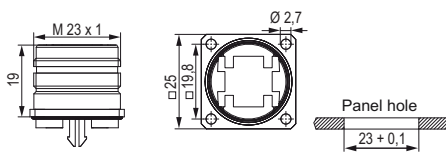
Panel Connector Front Mount, dip solder insert		Type	Part Number
		4 holes 2.7 mm, Flange	7.R40.008.000
		Incl. 8-pos dip solder insert	
		4 holes 2.7 mm, Flange	7.R40.082.000
		Incl. 8 + 2 pos dip solder insert	

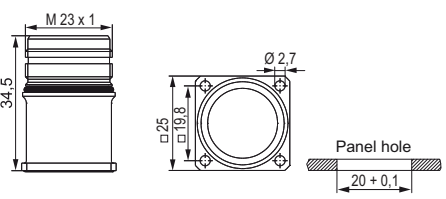
Panel Connector, Front Mount		Type	Part Number
		with vibration protection	
		4 holes 2.7 mm, Flange	7.R41.008.000
		Incl. 8-pos coupler, fully occupied	

Type	Part Number	Single Hole Panel Connector
Front Mount M 20 x 1,5 thread 7.R42.008.000 Incl. 8-pos coupler, fully occupied Optional: Gasket M 20 x 1,5, Locking Nut		

Type	Part Number	Single Hole Panel Connector
Rear Mount M 25 x 1,5 thread 7.R50.008.000 Incl. 8-pos coupler, fully occupied M 25 x 1,5 Locking Nut included		

Type	Part Number	Right Angle Panel Connector, Male Thread
300° rotating, locking screw at flange 4 holes 2.7 mm, Flange 7.R43.008.000 Incl. 8-pos coupler, fully occupied Optional: Gasket Simple installation with M 2.5 screws		

Type	Part Number	Panel Connector Rear Mount, dip solder insert
with vibration protection 4x M 3 thread, Flange 7.R45.008.000 Incl. 8-pos dip solder insert 4x M 3 thread, Flange 7.R45.082.000 Incl. 8 + 2-pos dip solder insert		

Connectors M 23 RJ 45 / Housing

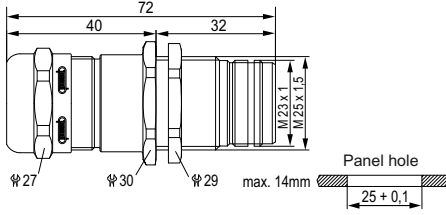
Single Hole Panel Connector with strain relief		Type	Part Number
		Single Hole, RearMount , M 25 x 1,5 thread 3 – 7 mm (.12 - .28") 7.R52.408.000 Incl. 8-pos coupler, fully occupied M 25 x 1,5 Locking Nut included	

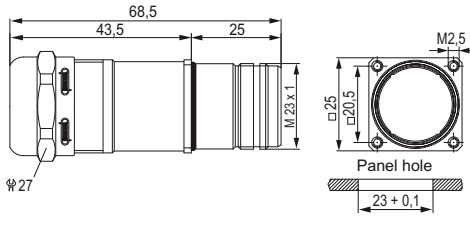
Panel Connector with strain relief		Type	Part Number
		4x M 2,5 thread, Flange, Rear Mount 3 – 7 mm (.12 - .28") 7.R47.408.000 Incl. 8-pos coupler, fully occupied	

Type	Part Number	Accessories
Plastic protective cap for connectors with male thread7.000.900.101 for connectors with female thread7.000.900.102		
Brass protective cap for connectors with female thread7.010.900.183		
Brass protective cap for connectors with male thread7.010.900.102		
Brass protective cap with chain for connectors with female threadLength 70 mm7.010.9S0.783Length 100 mm7.010.9S1.083		
Brass protective cap with chain for connectors with male threadLength 70 mm7.010.9S0.702Length 100 mm7.010.9S1.002		
Adapter for cable, Panel Connector, male thread7.010.900.128		

Connectors M 23 RJ 45 / Accessories

Accessories	Type	Part Number
	Adapter for Conduit Fittings	Snapflex 16..... 7.010.900.204 DN 12 7.010.900.205 Snapflex 20..... 7.010.900.206 DN 14 7.010.900.207 Snapflex 25..... 7.010.900.208 DN 17 7.010.900.209
	Suitable patch cableon request	
	Field Attachable RJ 45 Connector and Plugson request	

Straight Connector, Male Thread

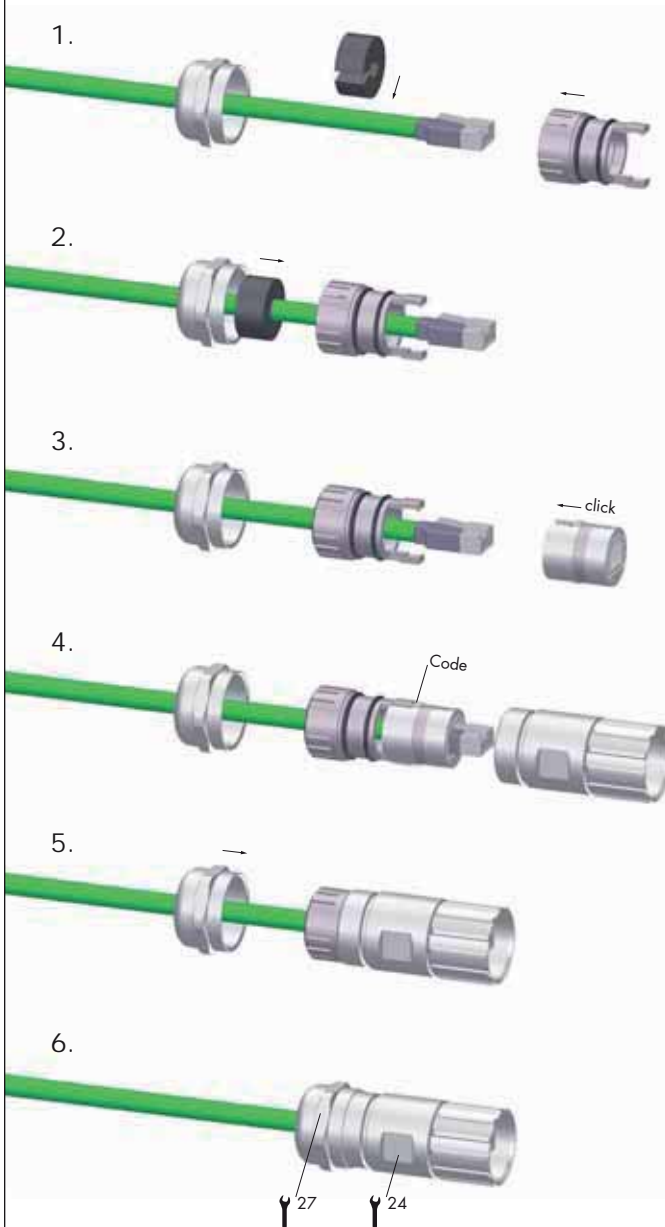

Male Threaded Connector

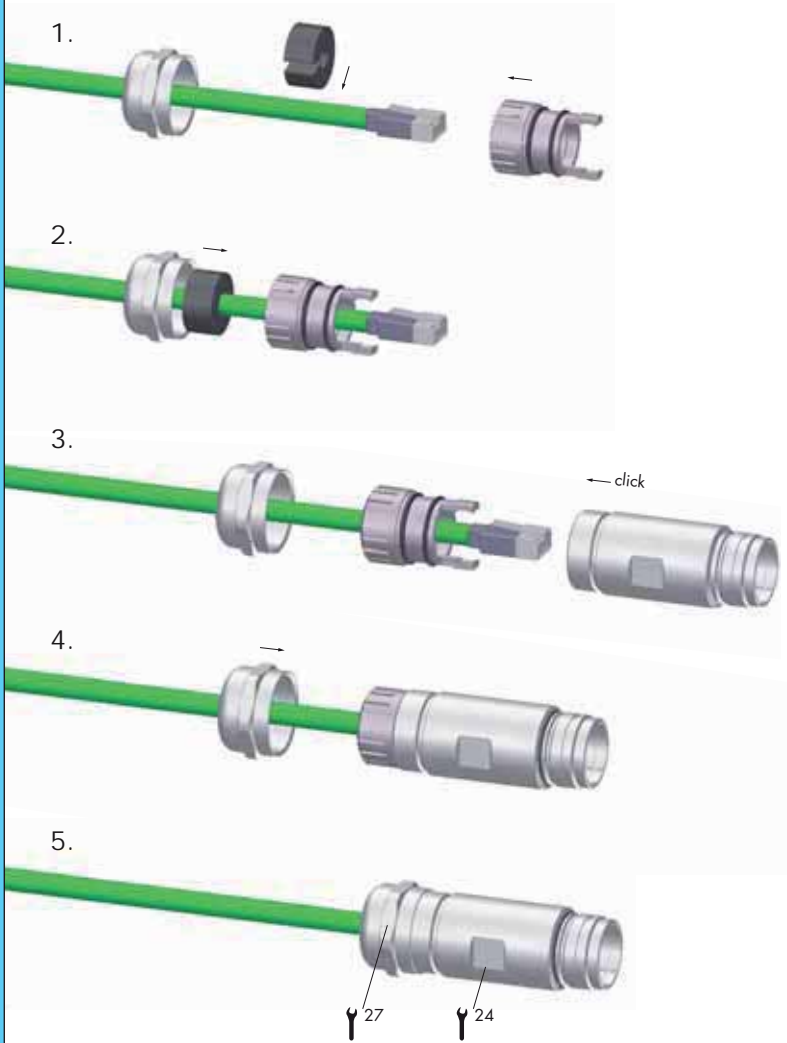

Signal Connectors M 23



Housings

page 64



Inserts

page 72

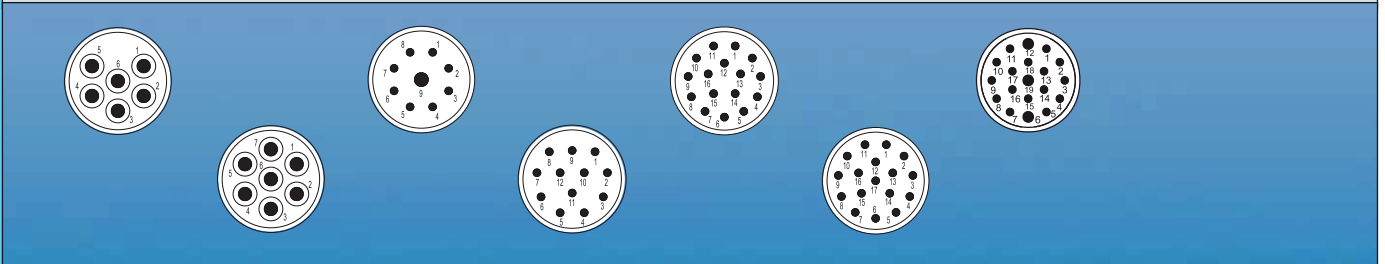

Accessories

page 80

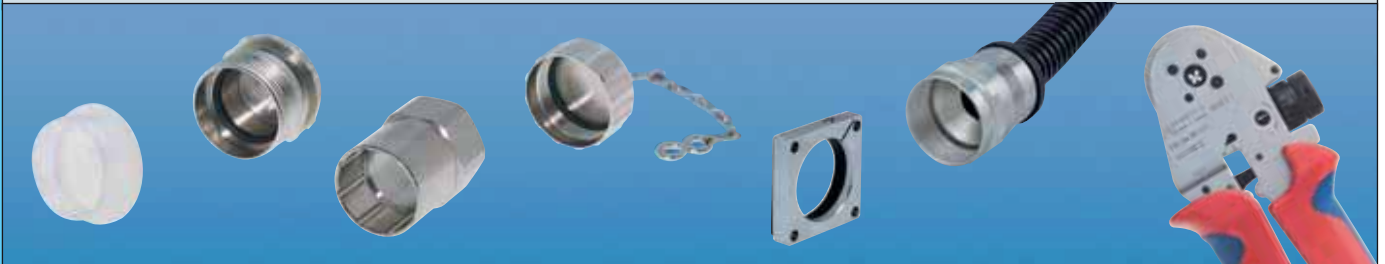

M 23 Signal Connectors

Mechanical Data	Materials and Technical Data
Housing	Copper-Zinc alloy Die Casting
Housing surface	Nickel plated brass other surface upon request
Inserts (for contacts)	Thermoplastic Polyamid PA 6 (Nylon 6/6), PBT Fire protection class V-0
Contacts	Brass Alloy
Contact surface at point of contact	Nickel and gold plated (0,25µm Au)
Minimum mating cycles	> 1000
Seals / O-Rings	Buna-N standard optional Viton® (Viton is a registered trademark of DuPont)
Temperature range	-40° C – 125° C (-40 °F – 257 °F)
Type of contacts	Crimp, solder, dip-solder (PCB)
Protection	IP 67 / IP 69K per EN 60529 (connected), NEMA 4x
Cable diameter range	3 – 17 mm (.12 – .55")

Electrical Data							
Number of positions	6	7	9 (8 + 1)	12	16	17	19 (16 + 3)
Number of contacts	6	7	8 1	12	16	17	16 3
Contact-Ø [mm]	2	2	1 2	1	1	1	1 1,5
Nominal current ¹⁾ [A]	20	20	8 20	8	8	8	8 10
Nominal voltage ²⁾ [V~] Degree of Protection 2 ³⁾	630	630	500	500	400	400	320
Nominal voltage ²⁾ [V~] Degree of Protection 3 ³⁾	300	300	200	200	160	160	100
Test voltage (Breakdown voltage) ⁴⁾ [V~]	2500	2500	2500	2500	1500	1500	1500
Insulation resistance [mΩ]	> 10 ¹⁰	> 10 ¹⁰	> 10 ¹⁰	> 10 ¹⁰	> 10 ⁶	> 10 ⁶	> 10 ⁶
Max. contact resistance) [mΩ]	3	3	3	3	3	3	3

^{1), 2), 3), 4)} See Technical Informations page 14

Derating

Straight Connectors male + female,
wires 12 x AWG 17

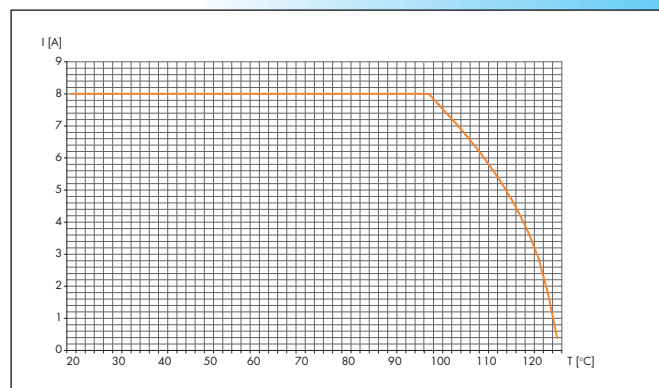

Signal Connectors M 23 / Housing

Straight Connector, Female Thread

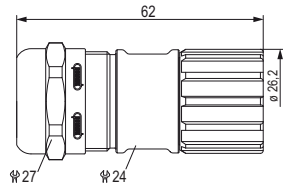

Cable-Ø

Part Number

3 – 7 mm (.12 – .28")	7.106.400.000
7 – 12 mm (.28 – .47")	7.106.500.000
11 – 17 mm (.44 – .67")	7.106.600.000

Contacts and inserts page 72 • Assembly instructions page 85

Straight Connector, Male Thread

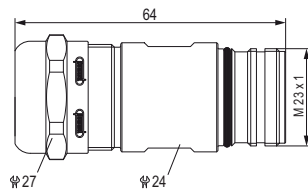

Cable-Ø

Part Number

3 – 7 mm (.12 – .28")	7.206.400.000
7 – 12 mm (.28 – .47")	7.206.500.000
11 – 17 mm (.44 – .67")	7.206.600.000

Contacts and inserts page 72 • Assembly instructions page 85

Panel Connector, Male Thread, with Strain Relief

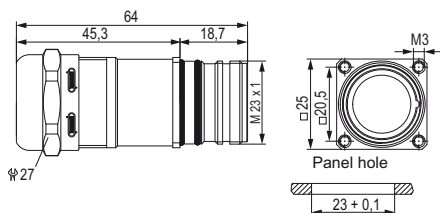

Cable-Ø

Part Number

4 threads M 3, rear mounting	
3 – 7 mm (.12 – .28")	7.476.400.000
7 – 12 mm (.28 – .47")	7.476.500.000
11 – 17 mm (.44 – .67")	7.476.600.000

Optional: Flat gasket

Contacts and inserts page 72 • Assembly instructions page 85

Panel Connector, Male Thread, with Strain Relief

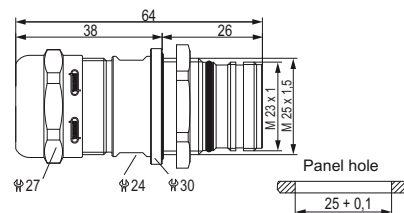

Cable-Ø

Part Number

Rear mounting, M25 x 1,5 single hole mounted	
3 – 7 mm (.12 – .28")	7.486.400.000
7 – 12 mm (.28 – .47")	7.486.500.000
11 – 17 mm (.44 – .67")	7.486.600.000

Including jam nut M25 x 1,5

Contacts and inserts page 72 • Assembly instructions page 85

Signal Connectors M 23 / Housing

Cable-Ø	Part Number	Right Angle Connector, Female Thread
3 – 7 mm (.12 – .28")	7.300.300.000	
5 – 10 mm (.20 – .39")	7.300.400.000	
7 – 12 mm (.28 – .47")	7.300.500.000	
10 – 14 mm (.39 – .55")	7.300.600.000	
Contacts and inserts page 72 • Assembly instructions page 86		

Cable-Ø	Part Number	Right Angle Connector, Female Thread, EMC
7 – 12 mm (.28 – .47")	7.301.500.000	
10 – 14 mm (.39 – .55")	7.301.600.000	
Contacts and inserts page 72 • Assembly instructions page 86		

Cable-Ø	Part Number	Right Angle Connector with positioning, EMC
7 – 12 mm (.28 – .47")	7.306.500.000	
11 – 17 mm (.43 – .67")	7.306.600.000	
Contacts and inserts page 72 • Assembly instructions page 87		

Cable-Ø	Part Number	Right Angle Connector, Male Thread
3 – 7 mm (.12 – .28")	7.350.300.000	
5 – 10 mm (.20 – .39")	7.350.400.000	
7 – 12 mm (.28 – .47")	7.350.500.000	
10 – 14 mm (.39 – .55")	7.350.600.000	
Contacts and inserts page 72 • Assembly instructions page 86		

Signal Connectors M 23 / Housing

Panel Connector, Male Thread, Front Mounting		Type	Part Number
		4 holes Ø 3,2 mm (.13").....	7.400.000.000
		4 threads M 3	7.402.000.000
		4 holes Ø 2,7 mm (.11").....	7.404.000.000
		4 threads M 2,5	7.406.000.000
		Optional: Flat gasket	
		Contacts and inserts page 72 • Assembly instructions page 89 / 90	

Panel Connector, Male Thread, Front Mounting		Type	Part Number
		With anti-vibration O-Ring	
		4 holes Ø 3,2 mm (.13").....	7.410.000.000
		4 threads M 3	7.412.000.000
		4 holes Ø 2,7 mm (.11").....	7.414.000.000
		4 threads M 2,5	7.416.000.000
		Optional: Flat gasket	
		Contacts and inserts page 72 • Assembly instructions page 89 / 90	

Panel Connector, Female Thread, with knurled Nut		Type	Part Number
		Without coding option	
		4 holes Ø 3,2 mm (.13").....	7.440.000.000
		4 holes Ø 2,7 mm (.11").....	7.444.000.000
		Optional: Flat gasket	
		Contacts and inserts page 72 • Assembly instructions page 88	

Panel Connector, Female Thread, with knurled Nut		Type	Part Number
		With coding option (8 x 45°)	
		4 holes Ø 3,2 mm (.13").....	7.448.000.000
		4 holes Ø 2,7 mm (.11").....	7.449.000.000
		Optional: Flat gasket	
		Contacts and inserts page 72 • Assembly instructions page 88	

Signal Connectors M 23/Housing

Type	Part Number	Panel Connector, Male Thread, Single Hole Mounted	
Front mounting for male inserts Thread M 20 x 1,5 7.420.000.000 Thread PG 13,5 7.422.000.000			
Optional: Flat gasket, jam nut M 20 x 1,5 / PG 13,5			
Contacts and inserts page 72 • Assembly instructions page 89			

Type	Part Number	Panel Connector, Male Thread, Single Hole Mounted	
Front mounting for female inserts Thread M 20 x 1,5 7.421.000.000 Thread PG 13,5 7.423.000.000			
Optional: Flat gasket, jam nut M 20 x 1,5 / PG 13,5			
Contacts and inserts page 72 • Assembly instructions page 90			

Type	Part Number	Panel Connector, Male Thread, Single Hole Mounted	
For insert with pins / sockets Thread M 25 x 1,5 7.425.000.000			
Optional: Flat gasket, jam nut M 25 x 1,5			
Contacts and inserts page 72 • Assembly instructions page 89 / 90			

Signal Connectors M 23 / Housing

Right Angle Panel Connector, Male Thread		Type	Part Number
		4 holes 2,7 mm (.11").....	7.435.000.000
		Optional: Flat gasket Easy fixation with M 2,5 screws Contacts and inserts page 72 • Assembly instructions page 91	

Right Angle Panel Connector, Male Thread		Type	Part Number
		335° rotating, hole mounted	Thread M 20 x 1,5
		7.431.000.000 Contacts and inserts page 72 • Assembly instructions page 91	

Right Angle Panel Connector, Male Thread		Type	Part Number
		335° rotating, hole mounted	Thread PG 13,5
		7.432.000.000 Contacts and inserts page 72 • Assembly instructions page 91	

Right Angle Panel Connector, Male Thread		Type	Part Number
		300° rotating, 1,5 mm locking screw at flange	4 x holes Ø 2,7 mm (.11") ..
		7.433.000.000 Flange 25 x 25 mm 4 x holes Ø 2,7 mm..... 7.433.100.000 Flange 28 x 28 mm Easy fixation with M 2,5 screws Contacts and inserts page 72 • Assembly instructions page 91	

Type	Part Number	Panel Connector, Male Thread, Rear Mounting
4 holes \varnothing 3,2 mm (.13")	7.450.000.000	
4 threads M 3	7.452.000.000	
4 holes \varnothing 2,7 mm (.11")	7.454.000.000	
4 threads M 2,5	7.456.000.000	
Optional: Flat gasket		
Contacts and inserts page 72 • Assembly instructions page 89 / 90		

Type	Part Number	Panel Connector, Male Thread, Rear Mounting
With anti-vibration O-Ring		
4 holes \varnothing 3,2 mm (.13")	7.460.000.000	
4 threads M 3	7.462.000.000	
4 holes \varnothing 2,7 mm (.11")	7.464.000.000	
4 threads M 2,5	7.466.000.000	
Optional: Flat gasket		
Contacts and inserts page 72 • Assembly instructions page 89 / 90		

Type	Part Number	Panel Connector, Male Thread, Single Hole Mounted
Rear mounting		
Thread M 25 x 1,5	7.458.000.000	
Including jam nut M 25 x 1,5		
Contacts and inserts page 72 • Assembly instructions page 89 / 90		

Type	Part Number	Panel Connector, Female Thread, Rear Mounting
With knurled nut, rear mounting		
4 threads M 3	7.459.000.000	
Contacts and inserts page 72 • Assembly instructions page 88		

Signal Connectors M 23 / Housing

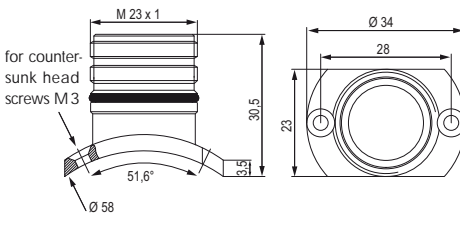
Panel Connector with Radius Flange		Type	Part Number
		With anti-vibration O-Ring and flat body gasket Ø 58 mm (2.28") 7.490.000.000	
		Contacts and inserts page 72 • Assembly instructions page 89 / 90	

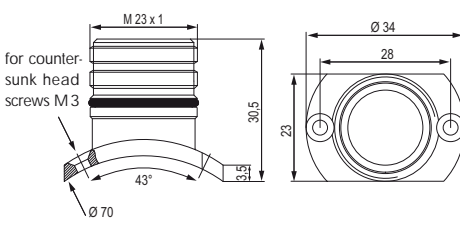
Panel Connector with Radius Flange		Type	Part Number
		With anti-vibration O-Ring and flat body gasket Ø 70 mm (2.76") 7.491.000.000	
		Contacts and inserts page 72 • Assembly instructions page 89 / 90	

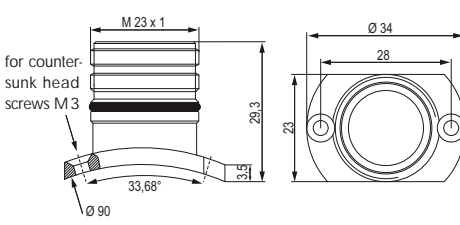
Panel Connector with Radius Flange		Type	Part Number
		With anti-vibration O-Ring and flat body gasket Ø 90 mm (3.54") 7.492.000.000	
		Contacts and inserts page 72 • Assembly instructions page 89 / 90	

Signal Connectors M 23 / Housing

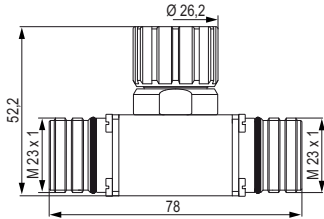

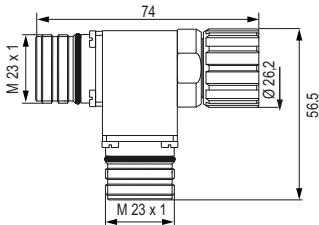
Type	Part Number	Signal Distribution
T 01	7.T01	
<p>Contacts and inserts page 72</p> 		

Type	Part Number	Signal Distribution
T 02	7.T02	
<p>Contacts and inserts page 72</p> 		

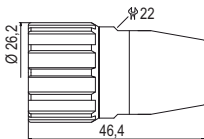
Signal Distribution
<p>In case of so called Flying Connections it is often required to distribute, cross or combine signals. Depending on the requirements of the application, the connections can be supplied either as male or female connector, or they can be configured with strain relief fittings. There are many possible combinations, including the internal wiring, independent of their style, as T-, Y-, H-, or other special configurations.</p> 

Type	Part Number	Bus End Connector
Closed type	7.105.000.000	
<p>Used to cap an open male connector in bus-systems</p> 		
<p>Contacts and inserts page 72</p>		

Signal Connectors M 23 / Inserts / Pinouts

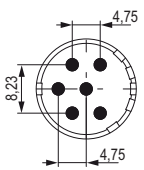
Inserts 6-pole	Type	Part Number	Part Number
 <p>Insert pin mating view</p>	Pinout clockwise	Pins	Sockets
	Insert with solder contacts	7.001.906.103	7.001.906.104
 <p>Insert socket mating view</p>	Insert without contacts.....	7.003.906.101	7.003.906.102
	Insert with dip solder contacts Length 3,5 mm	7.001.906.107	
	Insert with dip solder contacts Length 10 mm	7.001.906.127	7.001.906.108
	Insert with dip solder contacts Length 17 mm ¹⁾	7.001.906.137	7.001.906.118
The correct dimension of a connector with dip solder contacts depends on the particular type of housing.			
Contacts page 78 • Coding possibilities N, S, H, X and Y (see page 77)			

¹⁾ Under development

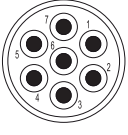
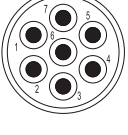
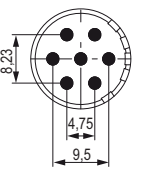
Inserts 7-pole	Type	Part Number	Part Number
 <p>Insert pin mating view</p>	Pinout clockwise	Pins	Sockets
	Insert with solder contacts	7.001.907.103	7.001.907.104
 <p>Insert socket mating view</p>	Insert without contacts.....	7.003.907.101	7.003.907.102
	Insert with dip solder contacts Length 3,5 mm	7.001.907.107	
	Insert with dip solder contacts Length 10 mm	7.001.907.127	7.001.907.108
	Insert with dip solder contacts Length 17 mm ¹⁾	7.001.907.137	7.001.907.118
The correct dimension of a connector with dip solder contacts depends on the particular type of housing.			
Contacts page 78 • Coding possibilities N, S, H, X and Y (see page 77)			

¹⁾ Under development

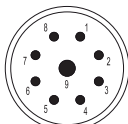
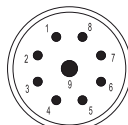
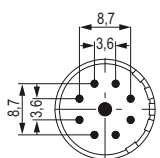
Type	Part Number	Part Number	Inserts 9-pole (8 + 1)
Pinout clockwise	Pins	Sockets	
Insert with solder contacts	7.001.981.103	7.001.981.104	 <p>Insert pin mating view</p>
Insert without contacts	7.003.981.101	7.003.981.102	
Insert with dip solder contacts Length 3,5 mm	7.001.981.107		 <p>Insert socket mating view</p>
Insert with dip solder contacts Length 10 mm	7.001.981.127	7.001.981.108	
Insert with dip solder contacts Length 17 mm ¹⁾	7.001.981.137	7.001.981.118	
<p>The correct dimension of a connector with dip solder contacts depends on the particular type of housing.</p>			
			
<p>Contacts page 78 • Coding possibilities N, S, H, X and Y (see page 77)</p>			

¹⁾ Under development

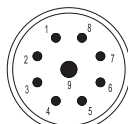
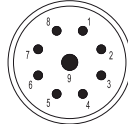
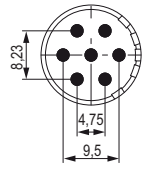
Type	Part Number	Part Number	Inserts 9-pole (8 + 1)
Pinout counter-clockwise	Pins	Sockets	
Insert with solder contacts	7.002.981.103	7.002.981.104	 <p>Insert pin mating view</p>
Insert without contacts	7.004.981.101	7.004.981.102	
Insert with dip solder contacts Length 3,5 mm	7.002.981.107		 <p>Insert socket mating view</p>
Insert with dip solder contacts Length 10 mm	7.002.981.127	7.002.981.108	
Insert with dip solder contacts Length 17 mm ¹⁾	7.002.981.137	7.002.981.118	
<p>The correct dimension of a connector with dip solder contacts depends on the particular type of housing.</p>			
			
<p>Contacts page 78 • Coding possibilities N, S, H, X and Y (see page 77)</p>			

¹⁾ Under development

Signal Connectors M 23 / Inserts / Pinouts

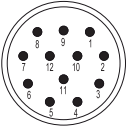
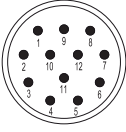
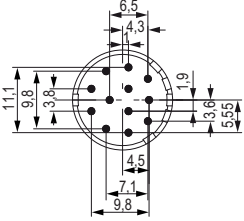
Inserts 12-pole	Type	Part Number	Part Number	
 <p>Insert pin mating view</p>  <p>Insert socket mating view</p> 	Pinout clockwise	Pins	Sockets	
	Insert with solder contacts	7.001.912.103	7.001.912.104	
	Insert with solder contacts +PE (Pos.9)	7.001.912.113	7.001.912.114	
	Insert without contacts	7.003.912.101	7.003.912.102	
	Insert without contacts +PE (Pos.9)	7.003.912.111	7.003.912.112	
	Insert with dip solder contacts Length 3,5 mm	7.001.912.107		
	Insert with dip solder contacts Length 10 mm	7.001.912.127	7.001.912.108	
	Insert with dip solder contacts Length 17 mm	7.001.912.137	7.001.912.118	
	<p>The correct dimension of a connector with dip solder contacts depends on the particular type of housing.</p>			
	<p>Contacts page 78 • Coding possibilities N, S, H, X and Y (see page 77)</p>			

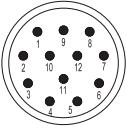
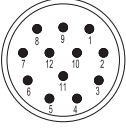
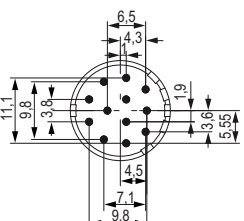
Inserts 12-pole	Type	Part Number	Part Number	
 <p>Insert pin mating view</p>  <p>Insert socket mating view</p> 	Pinout counter-clockwise	Pins	Sockets	
	Insert with solder contacts	7.002.912.103	7.002.912.104	
	Insert with solder contacts +PE (Pos.9)	7.002.912.113	7.002.912.114	
	Insert without contacts	7.004.912.101	7.004.912.102	
	Insert without contacts +PE (Pos.9)	7.004.912.111	7.004.912.112	
	Insert with dip solder contacts Length 3,5 mm	7.002.912.107		
	Insert with dip solder contacts Length 10 mm	7.002.912.127	7.002.912.108	
	Insert with dip solder contacts Length 17 mm	7.002.912.137	7.002.912.118	
	<p>The correct dimension of a connector with dip solder contacts depends on the particular type of housing.</p>			
	<p>Contacts page 78 • Coding possibilities N, S, H, X and Y (see page 77)</p>			

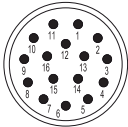
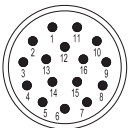
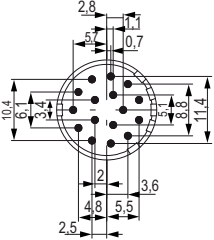
Type	Part Number	Part Number	Inserts 16-pole
Pinout clockwise	Pins	Sockets	
Insert with solder contacts	7.001.916.103	7.001.916.104	 <p>Insert pin mating view</p>
Insert without contacts	7.003.916.101	7.003.916.102	
Insert with dip solder contacts Length 3,5 mm	7.001.916.107		 <p>Insert socket mating view</p>
Insert with dip solder contacts Length 10 mm	7.001.916.127	7.001.916.108	
Insert with dip solder contacts Length 17 mm	7.001.916.137	7.001.916.118	
<p>The correct dimension of a connector with dip solder contacts depends on the particular type of housing.</p>			
			
<p>Contacts page 78 • Coding possibilities N, S, H, X and Y (see page 77)</p>			

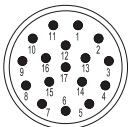
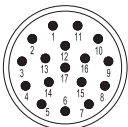
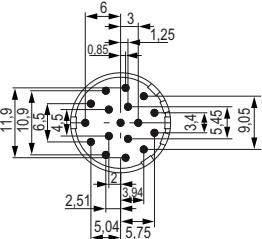
Type	Part Number	Part Number	Inserts 17-pole
Pinout clockwise	Pins	Sockets	
Insert with solder contacts	7.001.917.103	7.001.917.104	 <p>Insert pin mating view</p>
Insert without contacts	7.003.917.101	7.003.917.102	
Insert with dip solder contacts Length 3,5 mm	7.001.917.107		 <p>Insert socket mating view</p>
Insert with dip solder contacts Length 10 mm	7.001.917.127	7.001.917.108	
Insert with dip solder contacts Length 17 mm	7.001.917.137	7.001.917.118	
<p>The correct dimension of a connector with dip solder contacts depends on the particular type of housing.</p>			
			
<p>Contacts page 78 • Coding possibilities N, S, H, X and Y (see page 77)</p>			

Signal Connectors M 23 / Inserts / Pinouts

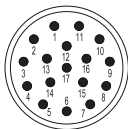
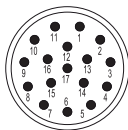
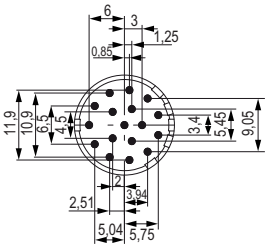
Inserts 17-pole	Type	Part Number	Part Number
 <p>Insert pin mating view</p>	Pinout counter-clockwise	Pins	Sockets
	Insert with solder contacts	7.002.917.103	7.002.917.104
 <p>Insert socket mating view</p>	Insert without contacts	7.004.917.101	7.004.917.102
	Insert with dip solder contacts Length 3,5 mm	7.002.917.107	
	Insert with dip solder contacts Length 10 mm	7.002.917.127	7.002.917.108
	Insert with dip solder contacts Length 17 mm	7.002.917.137	7.002.917.118
	<p>The correct dimension of a connector with dip solder contacts depends on the particular type of housing.</p>		
<p>Contacts page 78 • Coding possibilities N, S, H, X and Y (see page 77)</p>			

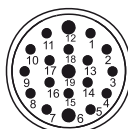
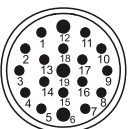
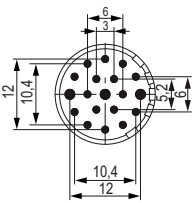
Inserts 19-pole	Type	Part Number	Part Number
 <p>Insert pin mating view</p>	Pinout clockwise	Pins	Sockets
	Insert with solder contacts	7.001.919.103	7.001.919.104
 <p>Insert socket mating view</p>	Insert with solder contacts +PE (Pos.12)	7.001.919.113	7.001.919.114
	Insert with solder contacts + PE (Pos.12) 1,5 mm elongated	7.001.919.123	
	Insert without contacts	7.003.919.101	7.003.919.102
	Insert without contacts +PE (Pos.12)	7.003.919.111	7.003.919.112
	Insert with dip solder contacts Length 3,5 mm	7.001.919.107	
	Insert with dip solder contacts Length 10 mm	7.001.919.127	7.001.919.108
	Insert with dip solder contacts Length 17 mm	7.001.919.137	7.001.919.118
<p>The correct dimension of a connector with dip solder contacts depends on the particular type of housing.</p>			
<p>Contacts page 78 • Coding possibilities N, S, H, X and Y (see page 77)</p>			

Signal Connectors M 23 / Required Contacts

Number of Poles	Required Contacts	Contact Arrangement
6	6 x 2 mm	
7	7 x 2 mm	
9 (8 + 1)	8 x 1 mm 1 x 2 mm	
12	12 x 1 mm	
16	16 x 1 mm	
17	17 x 1 mm	
19	16 x 1 mm 3 x 1,5 mm	

Crimp contacts page 78

Number of Poles	Coding Possibilities	Coding
6-pole	N, S, H, X, Y and Z	<p>Female Inserts mating view</p> <p>Male Inserts mating view</p>
7-pole	N, S, H, X and Y	
9-pole	N, S, H, X and Y	
12-pole	N, S, H, X, Y and Z	
16-pole	N, S, H, X, Y and Z	
17-pole	N, S, H, X, Y and Z	
19-pole	N, S, H, X and Y	

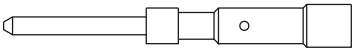
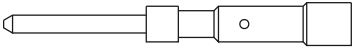
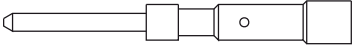
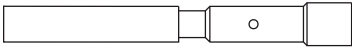
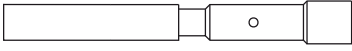
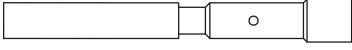
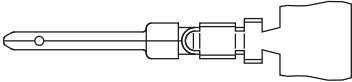
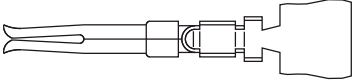
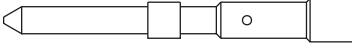

As standard, coding groove N is opened. To use other codings, please remove the coding barrier.

Signal Connectors M 23 / Contacts

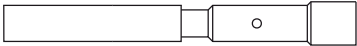
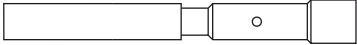
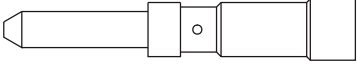
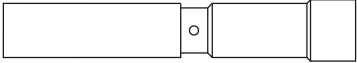
Contacts	Type	Crimp Range	Part Number
	Crimp pin 1 mm, machined0,08 – 0,56 mm ² (AWG 28 – 20)	7.010.901.031
	Crimp pin 1 mm, machined0,14 – 1 mm ² (AWG 26 – 17)7.010.901.001
	Crimppin 1 mm, machined1 – 1,5 mm ² (AWG 17 – 16)7.010.901.021
	Crimp socket 1 mm, machined	...0,08 – 0,56 mm ² (AWG 28 – 20)	..7.010.901.012
	Crimp socket 1 mm, machined	...0,34 – 1 mm ² (AWG 22 – 17)7.010.901.002
	Crimp socket 1 mm, machined	...1 – 1,5 mm ² (AWG 17 – 16)7.010.901.022
	Crimp pin 1 mm, stamped0,14 – 0,56 mm ² (AWG 26 – 20)	..upon request
	Crimp socket 1 mm, stamped0,14 – 0,56 mm ² (AWG 26 – 20)	..upon request
	Crimp pin 1,5 mm, machined	...0,14 – 1 mm ² (AWG 26 – 17)7.010.901.501

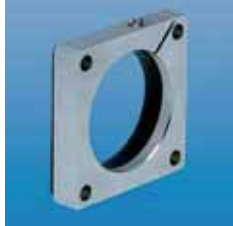

Type	Crimp Range	Part Number	Contacts
Crimp socket 1,5 mm, machined...	0,14 – 0,56 mm ² (AWG 26 – 20)	7.010.901.512	
Crimp socket 1,5 mm, machined...	0,56 – 1 mm ² (AWG 20 – 17)	7.010.901.502	
Crimp pin 2 mm, machined	0,75 – 2,5 mm ² (AWG 18 – 14)	7.010.902.001	
Crimp socket 2 mm, machined ...	0,75 – 2,5 mm ² (AWG 18 – 14)	7.010.902.002	

Accessories	Type	Part Number
	Plastic protective cap for connectors with male thread	7.000.900.101
	for connectors with female thread	7.000.900.102
	Brass protective cap for connectors with female thread	7.010.900.103
	Brass protective cap for connectors with male thread	7.010.900.102
	Brass protective cap with chain for connectors with female thread	Length 70 mm 7.010.9S0.703
		Length 100 mm 7.010.9S1.003
	Brass protective cap with chain for connectors with male thread	Length 70 mm 7.010.9S0.702
		Length 100 mm 7.010.9S1.002
	Assembly tool	7.010.900.101

Type	Part Number	Accessories
Crimp tool for manual crimping of machined crimp contacts for signal connectors	7.000.900.904	
Operating instructions on page 64		
Adaptor flange for Straight Connectors	7.010.900.128	
Adapter for Conduit Fittings	Snapflex 16.....7.010.900.204 DN 127.010.900.205 Snapflex 20.....7.010.900.206 DN 147.010.900.207 Snapflex 25.....7.010.900.208 DN 177.010.900.209	

Type	Part Number	for HUMMEL Contact	Locator
Locator for Crimp Tool DMC M22520 with positioner	7.000.9DM.C03	7.010.901.001, 7.010.901.501, 7.010.902.001	
Locator for Crimp Tool DMC M22520 with positioner	7.000.9DM.C04	7.010.901.012, 7.010.901.002, 7.010.901.512, 7.010.901.502, 7.010.902.002	

Crimp Tool for Signal Connectors M 23 / M 16

Crimp Tool	Type	Part Number
	<p>Crimp tool 7.000.900.904 / 7.000.900.907</p> <p>Application The four indent crimp tool 7.000.900.904 / 7.000.900.907 has been developed for optimal crimping of machined contacts with diameters from 0.08 to 2.5 mm² (28 through 14 AWG).</p> <p>How to Crimp The reference table indicates the correct locator position to be selected and the crimp depth to be adjusted for the contact to be crimped. The contact is then inserted through the access hole of the tool on the opposite side of the locator. The contact is held in place by closing the handles to the first lock-in position thus preventing the contact from falling out of the tool and facilitating insertion of the wire into the contact. The precision ratchet assures consistently accurate crimping every time by forcing the tool to be closed all the way completing the crimping cycle before the tool can be opened again.</p> <p>Exchange of the Locator The locator can be exchanged by removing the socket head cap screw with a socket wrench. It can then be disassembled from the hex head screw by turning it counter-clockwise.</p>	 <p>Crimp jaws</p> <p>Adjusting screw with 0.01 mm increments</p> <p>Scale indicating 0.2 mm increments</p> <p>Physical stop</p>

Crimp Tool

Adjustment of Crimp Depth

Crimp depth can be adjusted as follows:

Turn the adjusting screw clockwise for reducing the crimp depth and counter-clockwise for increasing the crimp depth.

Adjustment Increments:

- 1 space on the adjusting screw $\hat{=}$ adjustment by 0.01 mm
- 1 full rotation of adjusting screw $\hat{=}$ adjustment by 0.2 mm (indication on the screw as well as on the rough scale)
- 5 rotations of the adjusting screw $\hat{=}$ adjustment by 1 mm (indication on the scale)

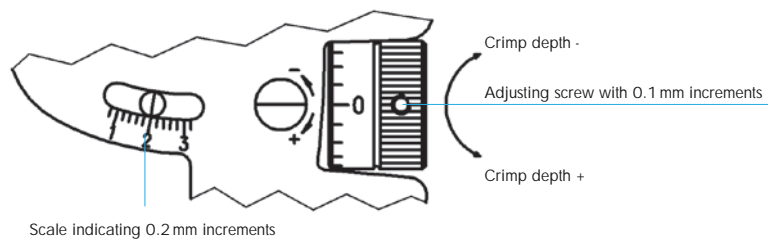

Control of Crimp Depth

Crimp tool adjustment is done at the factory, but with frequent use, periodic calibration is recommended to insure accuracy. This is easily accomplished with a 1.0 mm \varnothing wire gauge as follows.

A crimp depth of 1.0 mm is set by means of the adjusting screw (scale mark at „1“, screw mark at „0“ as shown in the fig. above) and the tool in the closed position. After insertion of the gauge, there must be just enough space for moving the gauge inside the entry hole. If the opening is too small or too large to exactly match the gauge, the deviation (+/-) can be checked by the precision setting of the screw. Please contact the factory in case the deviation exceeds the tolerances specified by the contract manufacturer.

Maintenance and Repair

Keep the tool clean and properly stored when not in service. All pivot points need to be oiled regularly and the spring clips securing the bolts have to always be in place. For repair please send the tool back to the factory.

Crimp Tool for Signal Connectors M 23

Crimp Tool Setting for HUMMEL Crimp Contacts (Crimp Tool 7.000.900.904)

Part Number	Crimp Contact	Cross Section (mm ²)	AWG	Crimp Tool Setting mm	Locator Setting
7.010.901.001	Crimp pin 1 mm	0,14	AWG 26	0,86	1
		0,25	AWG 24	0,90	
		0,34	AWG 22	0,95	
		0,56	AWG 20	0,98	
		0,75	AWG 18	1,03	
		1,00	AWG 17	1,08	
7.010.901.012	Crimp socket 1 mm (0,08 – 0,56 mm ²)	0,08	AWG 28	0,75	2
		0,14	AWG 26	0,78	
		0,25	AWG 24	0,82	
		0,34	AWG 22	0,86	
		0,56	AWG 20	0,90	
7.010.901.002	Crimp socket 1 mm (0,34 – 1 mm ²)	0,34	AWG 22	0,77	2
		0,56	AWG 20	0,82	
		0,75	AWG 18	0,88	
		1,00	AWG 17	0,95	
7.010.901.501	Crimp pin 1,5 mm	0,14	AWG 26	0,65	3
		0,25	AWG 24	0,68	
		0,34	AWG 22	0,72	
		0,56	AWG 20	0,81	
		0,75	AWG 18	0,95	
		1,00	AWG 17	1,07	
7.010.901.512	Crimp socket 1,5 mm (0,14 – 0,75 mm ²)	0,14	AWG 26	0,70	2
		0,25	AWG 24	0,73	
		0,34	AWG 22	0,77	
		0,56	AWG 20	0,85	
		0,75	AWG 18	1,05	
7.010.901.502	Crimp socket 1,5 mm (0,34 – 1 mm ²)	0,34	AWG 22	0,88	2
		0,56	AWG 20	0,95	
		0,75	AWG 18	1,05	
		1,0	AWG 17	1,13	
7.010.902.001	Crimp pin 2 mm	0,75	AWG 18	1,20	4
		1,0	AWG 17	1,35	
		1,5	AWG 16	1,45	
		2,5	AWG 14	1,60	
7.010.902.002	Crimp socket 2 mm	0,75	AWG 18	1,25	5
		1,0	AWG 17	1,35	
		1,5	AWG 16	1,45	
		2,5	AWG 14	1,60	

Assembly information see page 92

Signal Connectors M 23 / Assembly Instructions

Straight Connector, EMC

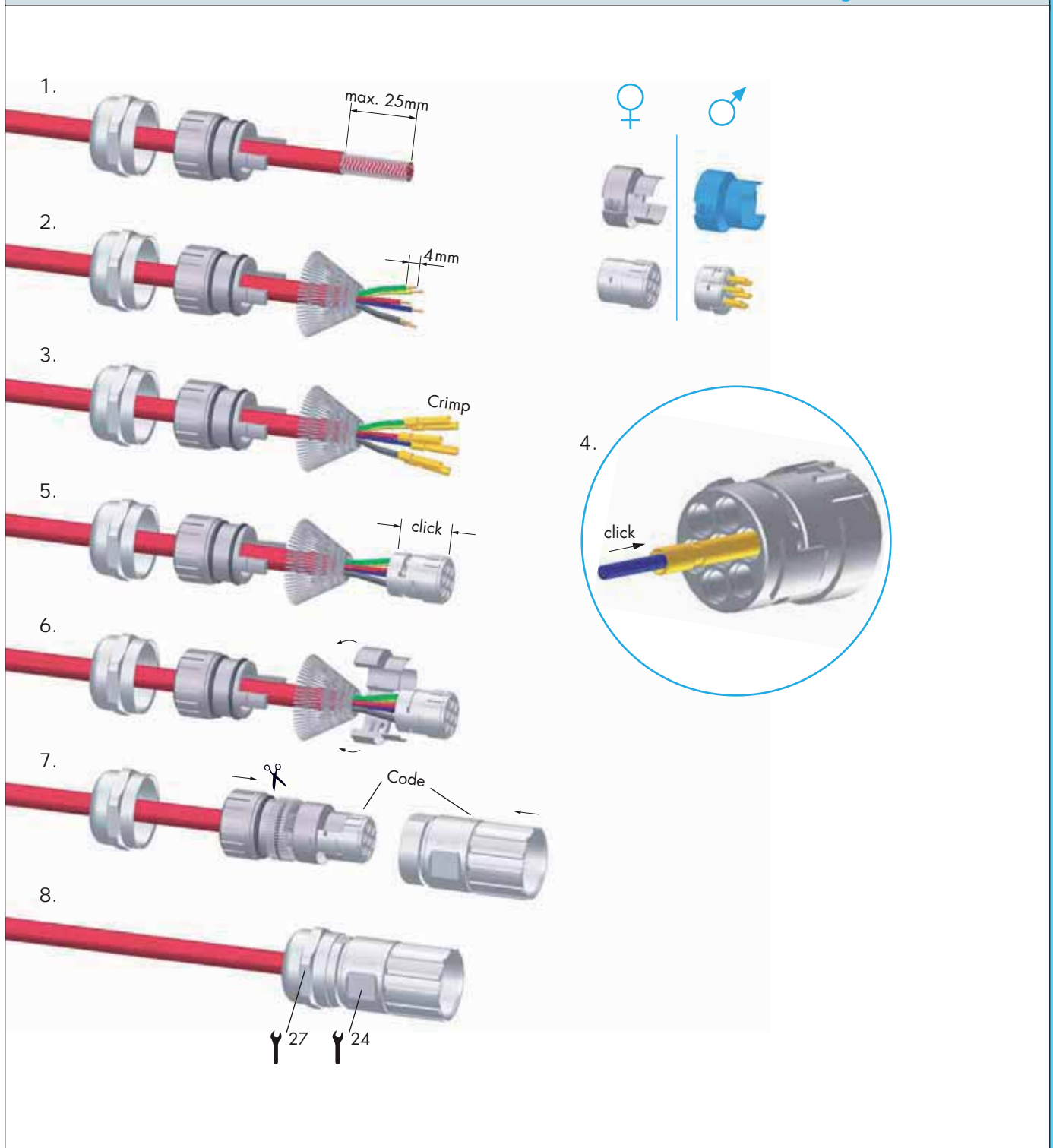

Signal Connectors M 23 / Assembly Instructions

Right Angle Connectors, EMC

1. Strip the cable by 60 mm.

2. Separate the shield and conductors.

3. Crimp the shield.

4. Crimp the conductors (4 mm).

5. Insert the conductor into the connector (click).

6. Insert the shield into the connector (click).

7. (Circular inset) Click mechanism.

8. Cut the shield with a 25 mm wrench.

9. Cut the shield with a 25 mm wrench.

10. Cut the shield with a 25 mm wrench.

11. Cut the shield with a 25 mm wrench.

12. Final assembly with a 27 mm wrench and a 24 mm wrench.

Signal Connectors M 23 / Assembly Instructions

Right Angle Connector with positioning, EMC

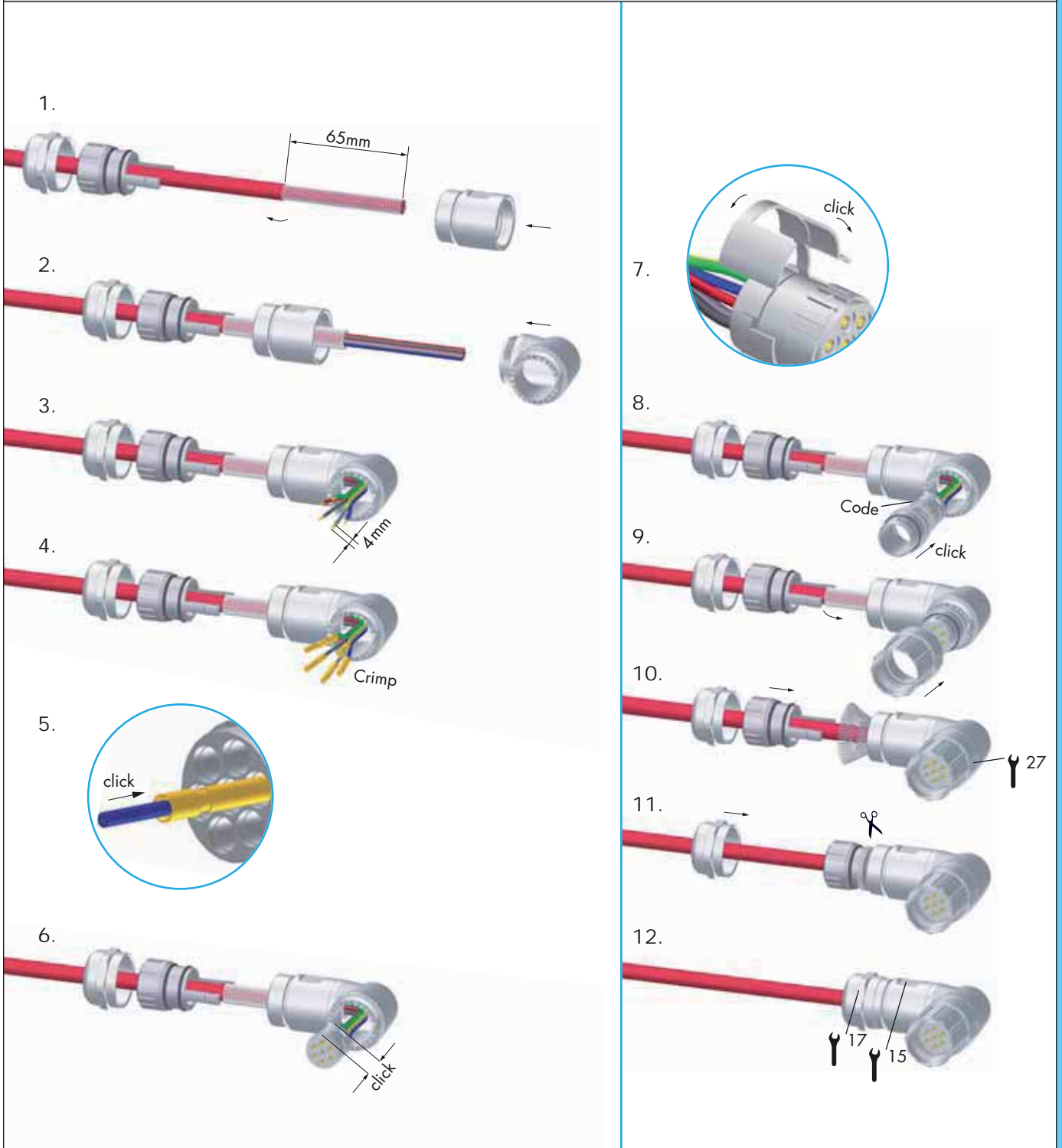

Panel Connector with knurled Nut

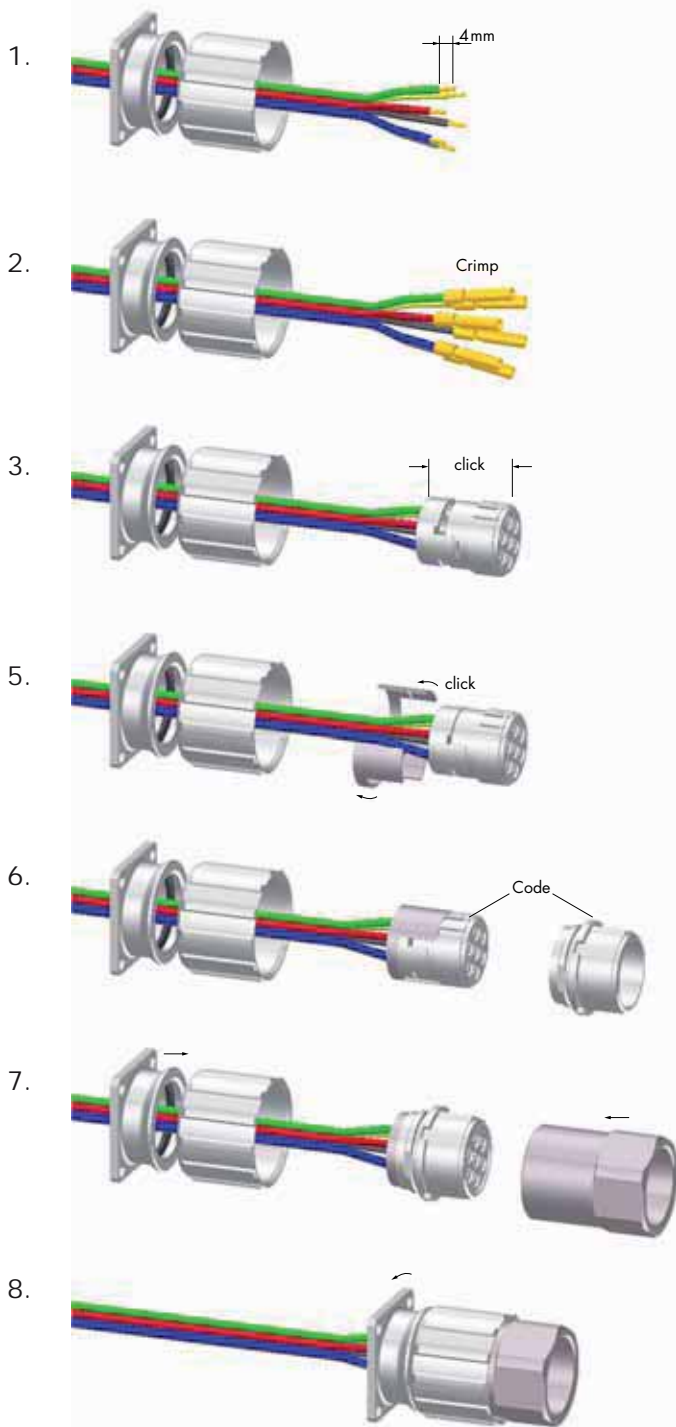

7.010.900.101

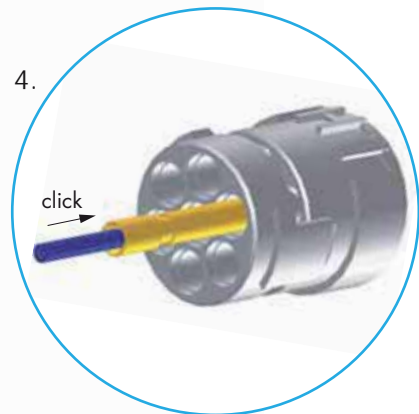

Panel Connectors, Male Inserts

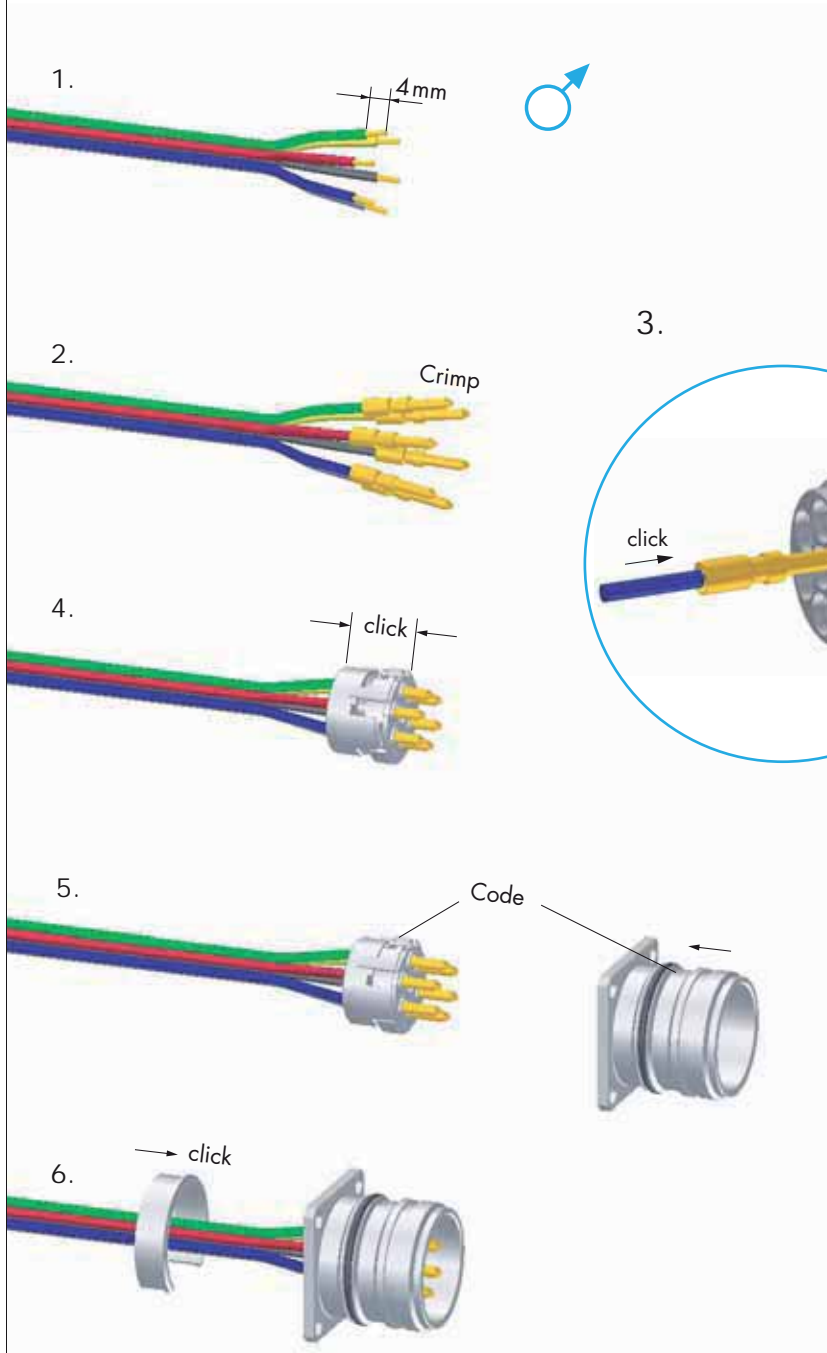

Panel Connectors, Female Inserts

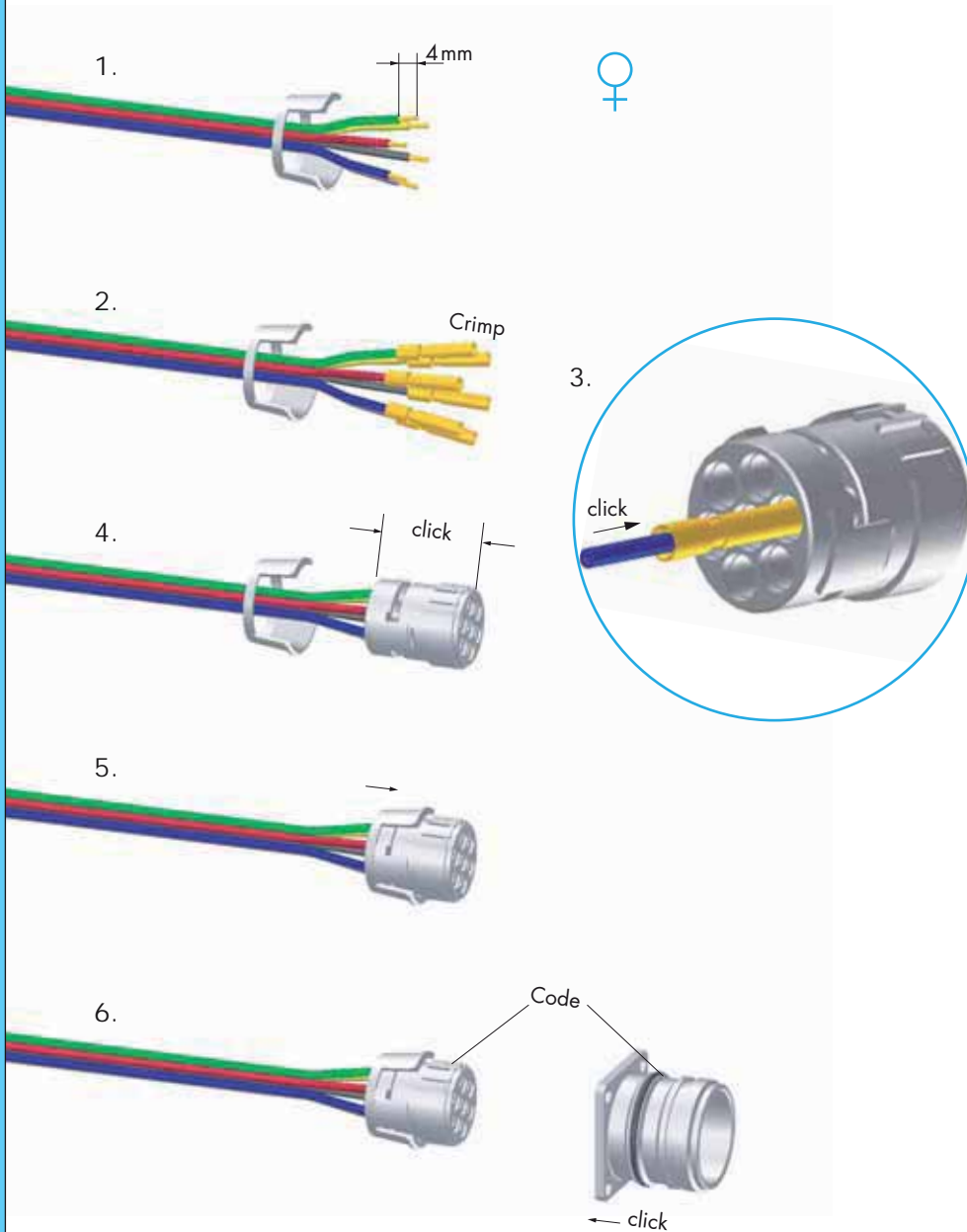

Right Angle Panel Connector

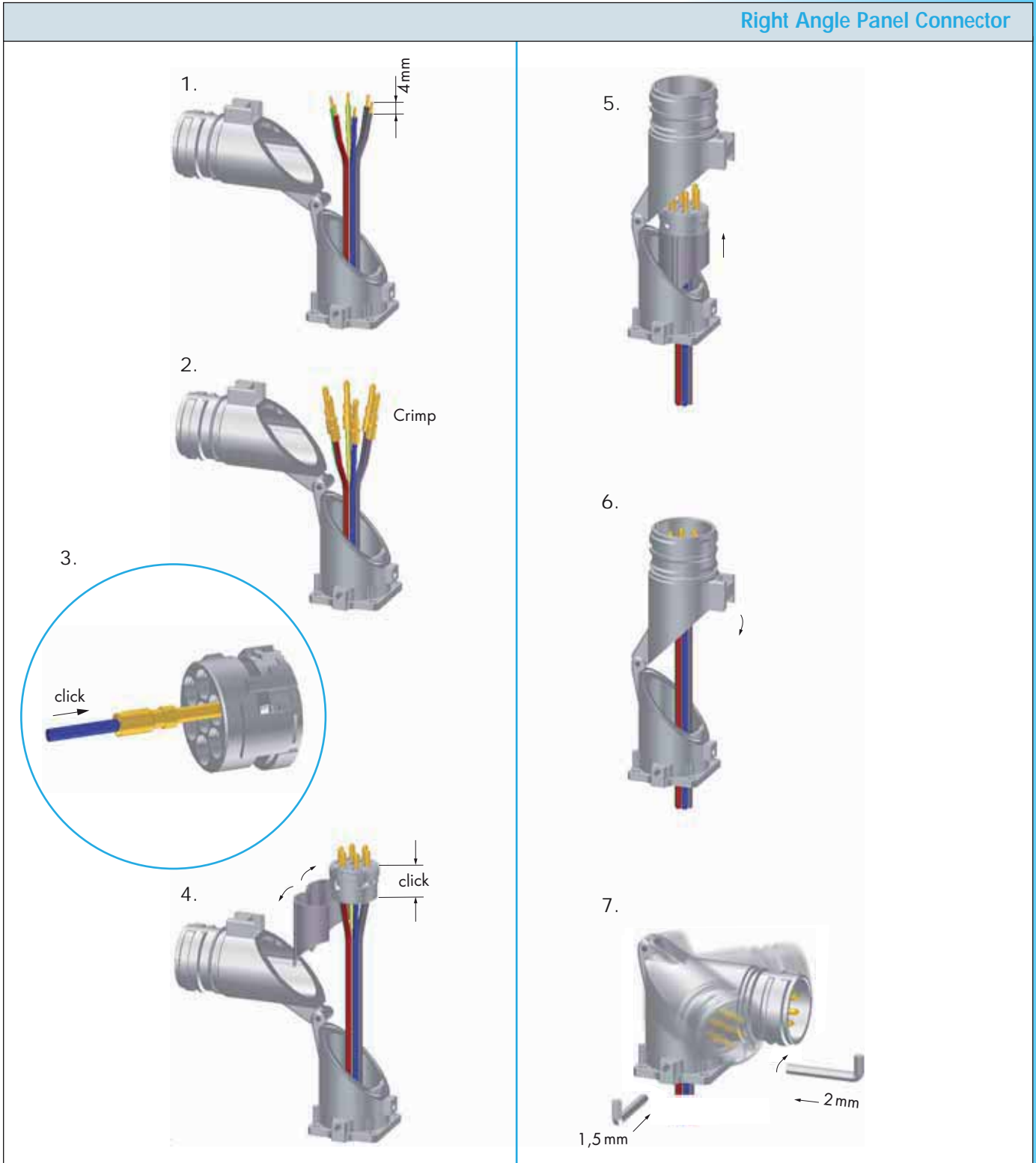

Crimping, Assembly and Disassembly of Contacts

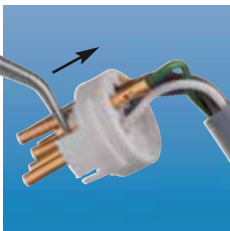

Crimping

- Remove conductor insulation 4 mm (.16") max.
- Select appropriate Crimp tool setting (see page 84)
- Insert Crimp contact into the positioner of the tool
- Insert stripped end of conductor into the crimp opening of the contact
- Squeeze handles of crimp tool together

Assembly

- Open crimping jaws and remove contact
- Pry open upper and lower insert approx. 3 mm (1/8") apart as shown
- Insert the contact and conductor assembly into the desired location
- Press upper and lower insert parts together

Disassembly

No special tools are needed to remove the crimp contacts from the insert.

- Remove upper part of insert
- With a pair of needle nose pliers, wiggle the contact and push it back through the lower part of insert
- Insert contacts into new location and push until it snaps in position
- Align the nose and groove of the upper and lower part of insert and press together

Shielding

- Assemble strain relief insert with insert
- Fold stranding of the shield back over the first O-Ring of the strain relief insert
- Cut back the overextending braid



The stranding of the shield is not allowed to touch the second O-Ring. Otherwise the assembly may not be proof.

Connectors M 27



Housings

page 96



Inserts

page 97

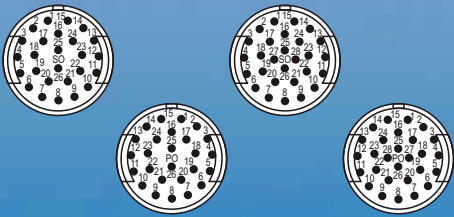

Accessories

page 99



M 23 Signal Connectors

Mechanical Data	Materials and Technical Data
Housing	Copper-Zinc alloy Die Casting
Housing surface	Nickel plated brass other surface upon request
Inserts (for contacts)	Thermoplastic Polyamid PA 6 (Nylon 6/6), PBT Fire protection class V-0
Contacts	Brass Alloy
Contact surface at point of contact	Nickel and gold plated (0,25µm Au)
Minimum mating cycles	> 1000
Seals / O-Rings	Buna-N standard optional Viton® (Viton is a registered trademark of DuPont)
Temperature range	-40° C – 125° C (-40 °F – 257 °F)
Type of contacts	Crimp, solder, dip-solder (PCB)
Protection	IP 67 / IP 69 K per EN 60529 (connected), NEMA 4x
Cable diameter range	3 – 17 mm (.12 – .55")

Electrical Data			
Number of positions		26	28
Number of contacts		26	28
Contact-Ø [mm]		1	1
Nominal current ¹⁾ [A]		8	8
Nominal voltage ²⁾ [V~]		150	150
Test voltage (Breakdown voltage) ³⁾ [V~]		1500	1500
Isolation resistance [MΩ]		> 10 ¹²	> 10 ¹²
Max. contact resistance [mΩ]		3	3
Degree of Protection ⁴⁾		3	3

^{1), 2), 3), 4)} See Technical Informations page 14

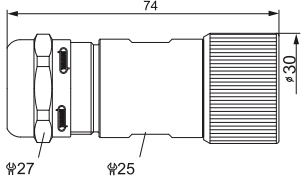

Signal Connectors M27 / Housing

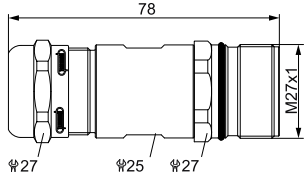
Straight Connector, Female Thread		Cable-Ø	Part Number
		7 – 12 mm (.28 - .47")	7.110.500.000
		11 – 17 mm (.43 - .67")	7.110.600.000
Contacts and inserts page 97 • Assembly instructions page 101			

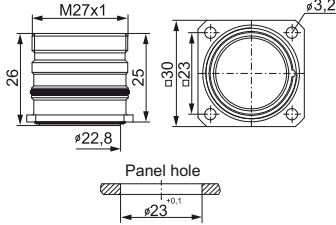

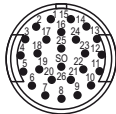
Straight Connector, Male Thread		Cable-Ø	Part Number
		7 – 12 mm (.28 - .47")	7.210.500.000
		11 – 17 mm (.43 - .67")	7.210.600.000
Contacts and inserts page 97 • Assembly instructions page 101			

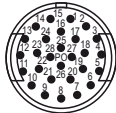
Panel Connector, Male Thread, front mounting		Type	Part Number
		4 x holes 3,2 mm	7.410.700.000
		Contacts and inserts page 97 • Assembly instructions page 102	



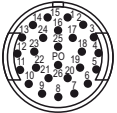

Type	Part Number	Part Number	Inserts 26-pole
Pinout clockwise	Pins	Sockets	
Insert with solder contacts	7.001.926.103	7.001.926.104	 Insert pin mating view
Insert without contacts	7.003.926.101	7.003.926.102	
Insert with dip solder contacts Length 3,5 mm	7.001.926.107		 Insert socket mating view
Insert with dip solder contacts Length 10 mm	7.001.926.127		
<p>The correct dimension of a connector with dip solder contacts depends on the particular type of housing.</p>			
Contacts page 98			

Type	Part Number	Part Number	Inserts 28-pole
Pinout clockwise	Pins	Sockets	
Insert with solder contacts	7.001.928.103	7.001.928.104	 Insert pin mating view
Insert with dip solder contacts Length 3,5 mm	7.001.928.107		
Insert with dip solder contacts Length 10 mm	7.001.928.127		 Insert socket mating view
<p>The correct dimension of a connector with dip solder contacts depends on the particular type of housing.</p>			
Contacts page 98			

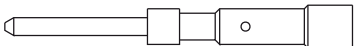
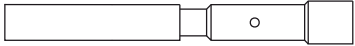
Signal Connectors M 27 / required contacts

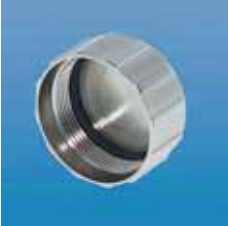
Contact Arrangement	Number of Poles	Required Contacts
	26	26 x 1 mm
	28	28 x 1 mm

Contacts	Type	Crimp Range	Part Number
	Crimp pin 1 mm, machined	0,14 – 1 mm ² (AWG 26 – 17)	7.010.971.001
	Crimp socket 1 mm, machined ...	0,14 – 1 mm ² (AWG 26 – 17)	7.010.971.002

Type	Part Number	Accessories
Plastic protective cap for connectors with male thread7.000.980.167 for connectors with female thread7.000.980.168		
Brass protective cap for connectors with female thread7.010.900.169 Brass protective cap with chain for connectors with female threadLength 70 mm7.010.9S0.707		
Brass protective cap for connectors with male thread7.010.900.170 Brass protective cap with chain for connectors with male threadLength 70 mm7.010.9S0.708		
Crimp tool for manual crimping of machined crimp contacts. Works with contacts for power or signal M23.7.000.900.901 See page 116/117 for crimp tool instructions and page 100 proper setting		
Assembly tool7.010.900.110		

Signal Connectors M 27 / Assembly Instructions

Crimp Tool Setting for HUMMEL Crimp Contacts (Crimp Tool 7.000.900.901)

Part Number	Crimp Contact	Cross Section mm ²	AWG	Crimp Tool Setting mm	Locator Setting
7.010.971.001	Crimp pin (signal) 1 mm	0,14	26	0,70	1
		0,25	24	0,80	1
		0,34	22	0,88	1
		0,50	20	0,95	1
		0,75	18	1	1
		1	17	1,03	1
7.010.971.002	Crimp socket (signal) 1 mm	0,14	26	0,70	4
		0,25	24	0,80	4
		0,34	22	0,88	4
		0,50	20	0,95	4
		0,75	18	1	4
		1	17	1,03	4

These values are only guidelines and actual conductor cross sections depend on manufacturer tolerances.

Straight Connector, Female Thread

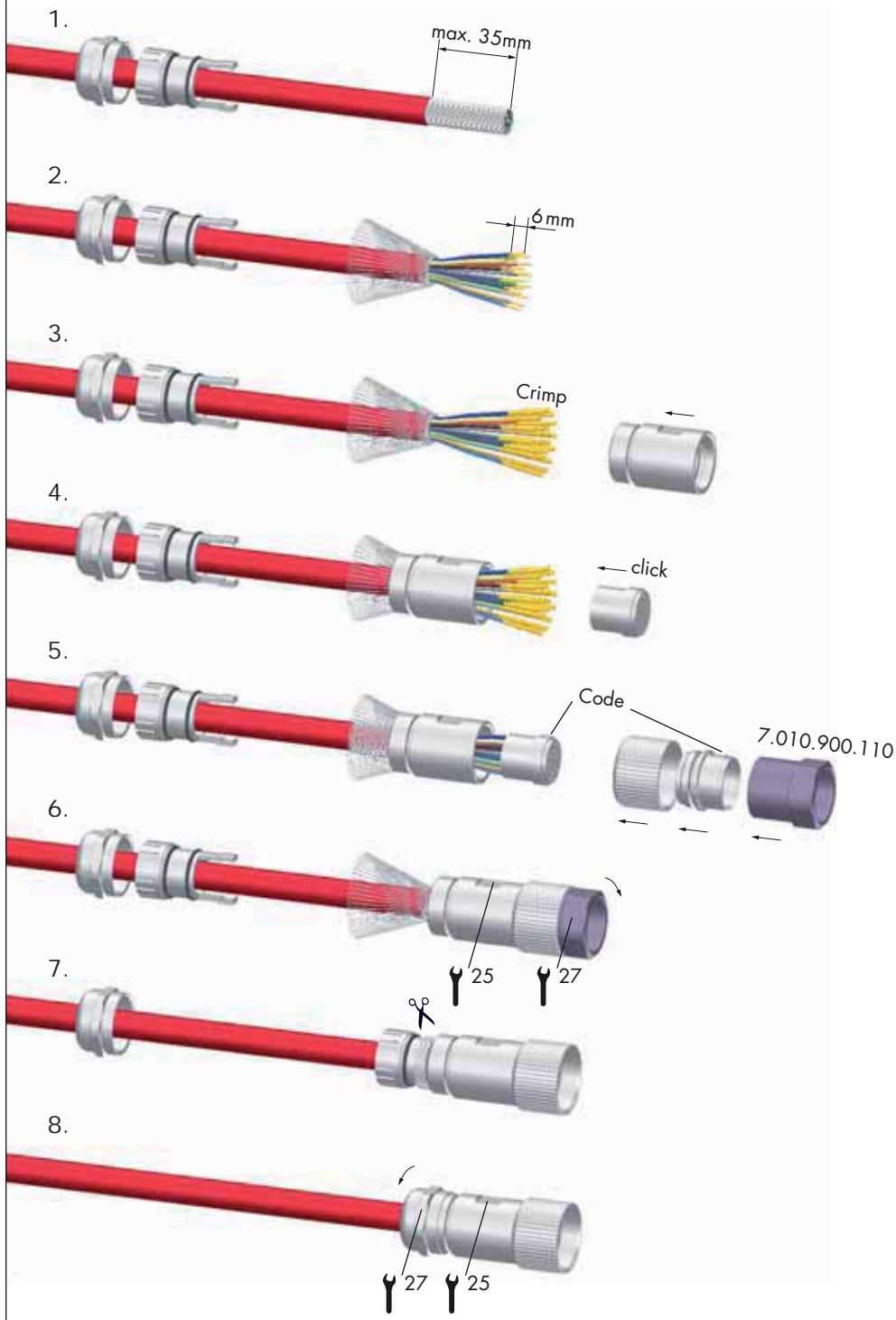

Panel Connector

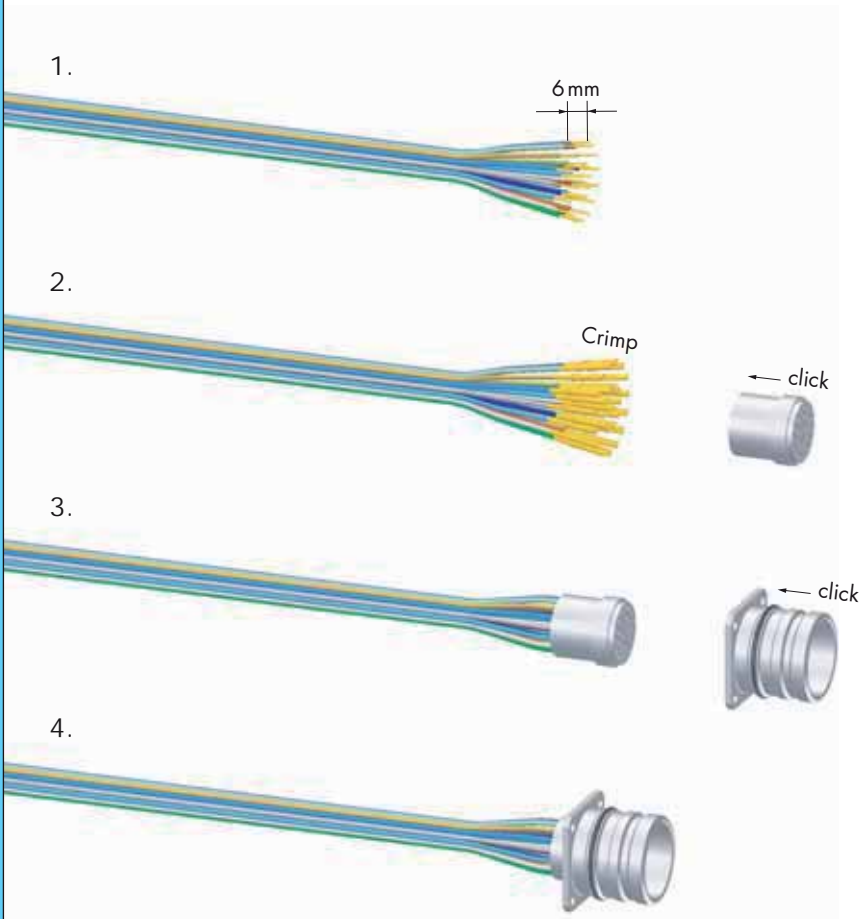

Power Connectors M 23



Housings

page 106



Inserts

page 112

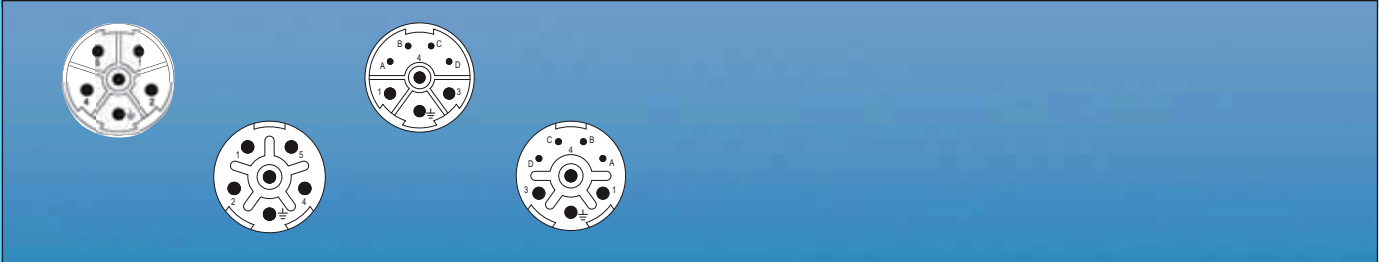

Accessories

page 114



Power Connectors M 23

Mechanical Data	Materials and Technical Data
Housing	Copper-Zinc alloy Die Casting
Housing surface	Nickel plated brass (standard) other surface upon request
Inserts (for contacts)	Thermoplastic Polyamid PA 6 (Nylon 6/6), PBT Fire protection class V-0
Contacts	Brass Alloy
Contact surface at point of contact	Nickel and gold plated (0,25 µm Au)
Minimum mating cycles	> 1000
Seals / O-Rings	Buna-N standard optional Viton® (Viton is a registered trademark of DuPont)
Temperature range	-40° C – 125° C (-40 °F – 257 °F)
Type of contacts	Crimp
Protection	IP 67 / IP 69 K per EN 60 529 (connected), NEMA 4x
Cable diameter range	7 – 17 mm (.28 – .55")

Electrical Data

	5 + PE	4 + 3 + PE	
Number of positions			
Number of contacts	6	4	4
Contact-Ø [mm]	2	1	2
Nominal current ¹⁾ [A]	28	8	28
Nominal voltage ²⁾ [V~] Degree of Protection 2 ³⁾	800	300	800
Nominal voltage ²⁾ [V~] Degree of Protection 3 ³⁾	600	300	600
Test voltage (Breakdown voltage) ⁴⁾ [V~]	4000	2500	4000
Insulation resistance [mΩ]	> 10 ¹³	> 10 ¹³	
Max. contact resistance) [mΩ]	3	3	

¹⁾, ²⁾, ³⁾, ⁴⁾ See Technical Informations page 14

Derating

Straight connectors male + female M 23, 5 + PE,
wires 5 x AWG 12

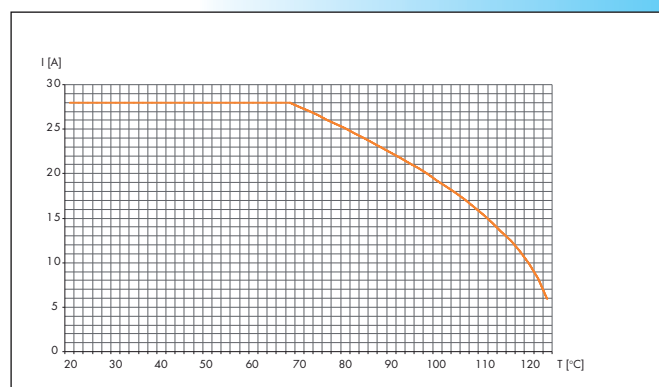

Power Connectors M 23 / Housing

Straight Connector, Female Thread

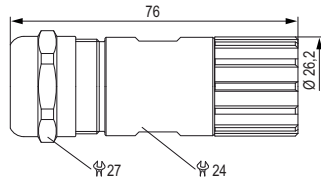

Cable-Ø

Part number

7 – 12 mm (.24 – .47").....7.550.500.000
 11 – 17 mm (.43 – .67").....7.550.600.000

Contacts and inserts page 112 • Assembly instructions page 120

Straight Connector, Female Thread, MZ

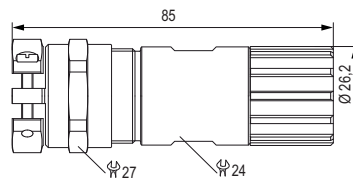

Cable-Ø

Part Number

10 – 12 mm (.39 – .47").....7.559.500.000
 11 – 17 mm (.43 – .67").....7.559.600.000

Contacts and inserts page 112 • Assembly instructions page 120

Straight Connector, Male Thread

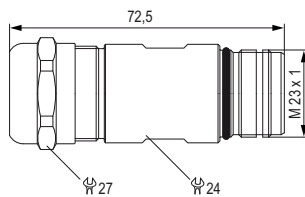

Cable-Ø

Part Number

7 – 12 mm (.24 – .47").....7.560.500.000
 11 – 17 mm (.43 – .67").....7.560.600.000

Contacts and inserts page 112 • Assembly instructions page 120

Straight Connector, Male Thread, MZ

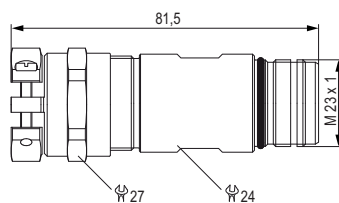

Cable-Ø

Part Number

10 – 12 mm (.39 – .47").....7.569.500.000
 11 – 17 mm (.43 – .67").....7.569.600.000

Contacts and inserts page 112 • Assembly instructions page 120

Power Connectors M 23 / Housing

Cable-Ø	Part Number	Right Angle Connector with positioning, Female Thread
7 – 12 mm (.24 – .47")7.570.500.000	
11 – 17 mm (.43 – .67")7.570.600.000	
<p>Contacts and inserts page 112 • Assembly instructions page 122</p>		



Cable-Ø	Part Number	Right Angle Connector with positioning, Female Thread, MZ
9 – 12 mm (.35 – .47")7.579.500.000	
10 – 14 mm (.39 – .55")7.579.600.000	
<p>Contacts and inserts page 112 • Assembly instructions page 122</p>		



Cable-Ø	Part Number	Right Angle Connector, Male Thread
7 – 12 mm (.24 – .47")7.580.500.000	
10 – 14 mm (.39 – .55")7.580.600.000	
<p>Contacts and inserts page 112 • Assembly instructions page 122</p>		



Cable-Ø	Part Number	Right Angle Connector, Male Thread, MZ
9 – 12 mm (.35 – .47")7.589.500.000	
10 – 14 mm (.39 – .55")7.589.600.000	
<p>Contacts and inserts page 112 • Assembly instructions page 122</p>		

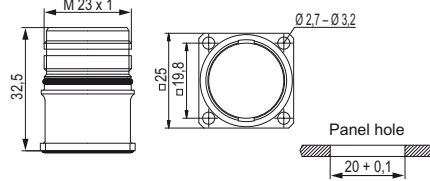

Power Connectors M 23 / Housing

Panel Connectors, Male Thread, Front Mounting		Type	Part Number
		4 holes \varnothing 3,2 mm (.13").....	7.601.000.000
		4 holes \varnothing 2,7 mm (.11").....	7.605.000.000
		Optional: Flat gasket	
		Contacts and inserts page 112 • Assembly instructions page 121	

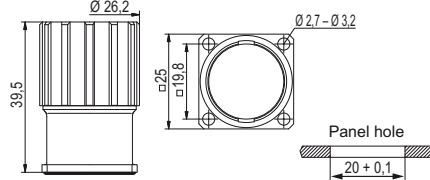
Panel Connector with knurled Nut, Front Mounting		Type	Part Number
		4 holes \varnothing 3,2 mm (.13").....	7.641.000.000
		4 holes \varnothing 2,7 mm (.11").....	7.645.000.000
		Optional: Flat gasket	
		Contacts and inserts page 112 • Assembly instructions page 123	

Type	Part Number	Panel Connector, Male Thread, Single Hole Mounted	
Front mounting Thread M 20 x 1,5 7.621.000.000 Options: Flat gasket, jam nut M 20 x 1,5			
<small>Contacts and inserts page 112 • Assembly instructions page 124</small>			

Type	Part Number	Panel Connector, Male Thread, Single Hole Mounted	
Front mounting Thread PG 13,5 7.623.000.000 Options: Flat gasket, jam nut PG 13,5			
<small>Contacts and inserts page 112 • Assembly instructions page 124</small>			

Type	Part Number	Panel Connector, Male Thread, Single Hole Mounted	
Front mounting Thread M 25x1,5 7.626.000.000 Options: Flat gasket, jam nut M 25 x 1,5			
<small>Contacts and inserts page 112 • Assembly instructions page 124</small>			

Type	Part Number	Panel Connector, Male Thread, Single Hole Mounted	
Rear mounting Thread M 25 x 1,5 7.651.000.000 Including jam nut M 25 x 1,5			
<small>Contacts and inserts page 112 • Assembly instructions page 124</small>			

Power Connectors M 23 / Housing

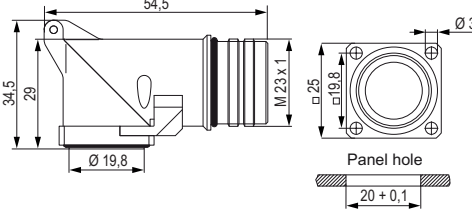
Right Angle Panel Connector, Male Thread		Type	Part Number
		4 holes \varnothing 2,7 mm (.11").....7.635.000.000	
		Options: Flat gasket Easy fastening with M2,5 x 10 mm or # 4 x .39" long screws Contacts and inserts page 112 • Assembly instructions page 125	

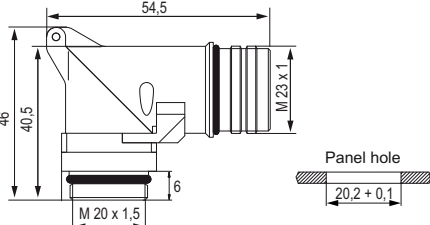
Right Angle Panel Connector, Male Thread		Type	Part Number
		335° rotatable, single hole mounted	
		Thread M 20 x 1,57.636.000.000 Contacts and inserts page 112 • Assembly instructions page 125	

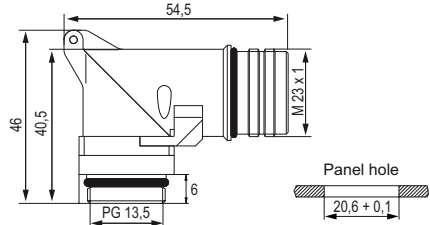
Right Angle Panel Connector, Male Thread		Type	Part Number
		335° rotatable, single hole mounted	
		Thread PG 13,57.637.000.000 Contacts and inserts page 112 • Assembly instructions page 125	

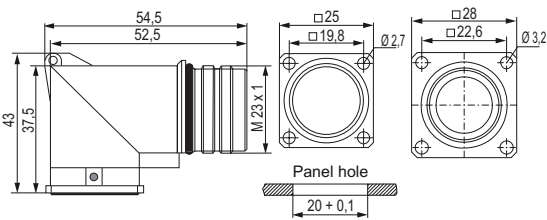
Rotating Panel Elbow Connector		Type	Part Number
		300° rotating, locking screw at flange	
		4 x holes \varnothing 2,7 mm (.11") ..7.638.000.000 Flange 25 x 25 mm 4 x holes \varnothing 3,2 mm (.13") ..7.638.100.000 Flange 28 x 28 mm Contacts and inserts page 112 • Assembly instructions page 125	

Type	Part Number	Panel Connector, Male Thread, Rear Mounting	
With anti-vibration O-Ring 4 holes \varnothing 3,2 mm (.13").....7.661.000.000			
Contacts and inserts page 112 • Assembly instructions page 121			







Cable- \varnothing	Part Number	Panel Connector, Male Thread, with Strain Relief	
Single hole mounted, rear mounting, thread M 25 x 1,5 7 – 12 mm (.27 – .47").....7.653.500.000 11 – 17 mm (.43 – .67").....7.653.600.000			
Including jam nut M 25 x 1,5		Contacts and inserts page 112 • Assembly instructions page 120	

Cable- \varnothing	Part Number	Panel Connector, Female Thread, with Strain Relief	
4 holes \varnothing 3,2 mm (.13"), front or rear mounting 7 – 12 mm (.27 – .47").....7.681.500.000 11 – 17 mm (.43 – .67").....7.681.600.000			
Contacts and inserts page 112 • Assembly instructions page 120		Contacts and inserts page 112 • Assembly instructions page 120	

Cable- \varnothing	Part Number	Panel Connector, Male Thread, with Strain Relief	
4 holes \varnothing 3,2 mm (.13"), front or rear mounting 7 – 12 mm (.27 – .47").....7.683.500.000 11 – 17 mm (.43 – .67").....7.683.600.000			
Contacts and inserts page 112 • Assembly instructions page 120		Contacts and inserts page 112 • Assembly instructions page 120	





Power Connectors M 23 / Contacts



Contact Arrangement, Mating View	Type of Contact	Part Number
	6 x crimp pins 2 mm	7.084.951.101
	6 x crimp sockets 2 mm	7.084.951.102
	4 x crimp pins 1 mm 4 x crimp pins 2 mm	7.084.943.101
	4 x crimp sockets 1 mm 4 x crimp sockets 2 mm	7.084.943.102

Type of Contact	Crimp Range	Part Number	Contacts
Crimp pin 1 mm, machined	0,25 – 1 mm ² (AWG 24 – 17)	7.010.941.001	
Crimp socket 1 mm, machined	0,25 – 1 mm ² (AWG 24 – 17)	7.010.941.002	
Crimp pin 2 mm, machined	0,75 – 2,5 mm ² (AWG 18 – 14)	7.010.942.001	
Crimp pin 2 mm, machined	2,5 – 4 mm ² (AWG 14 – 12)	7.010.942.011	
Crimp socket 2 mm, machined	0,75 – 2,5 mm ² (AWG 18 – 14)	7.010.942.002	
Crimp socket 2 mm, machined	2,5 – 4 mm ² (AWG 14 – 12)	7.010.942.012	

See page 126 for crimp tool instructions and proper setting

Power Connectors M 23 / Accessories

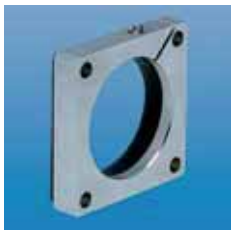
Accessories	Type	Part Number
	Plastic protective cap for connectors with male thread for connectors with female thread	7.000.900.101 7.000.900.102
	Brass protective cap for connectors with female thread	7.010.900.183
	Brass protective cap for connectors with male thread	7.010.900.102
	Brass protective cap with chain for connectors with female threadLength 70 mm Length 100 mm	7.010.9S0.783 7.010.9S1.083
	Brass protective cap with chain for connectors with male threadLength 70 mm Length 100 mm	7.010.9S0.702 7.010.9S1.002

Type	Part Number	Accessories
Crimp tool for manual crimping of machined crimp contacts. Works with contacts for power or signal.....	7.000.900.901	
Operating instructions on page 116		
Adaptor flange for Straight Connectors	7.010.900.128	
Adapter for Conduit Fittings	Snapflex 16.....7.010.900.204 DN 127.010.900.205 Snapflex 20.....7.010.900.206 DN 147.010.900.207 Snapflex 25.....7.010.900.208 DN 177.010.900.209	

Type	Part Number	for HUMMEL Contact	Locator
Locator for Crimp Tool DMC M22520 with positioner	7.000.9DM.C06	7.010.941.001, 7.010.942.001	
Locator for Crimp Tool DMC M22520 with positioner	7.000.9DM.C07	7.010.941.002, 7.010.942.002	

Crimp Tool for Power Connectors M 23

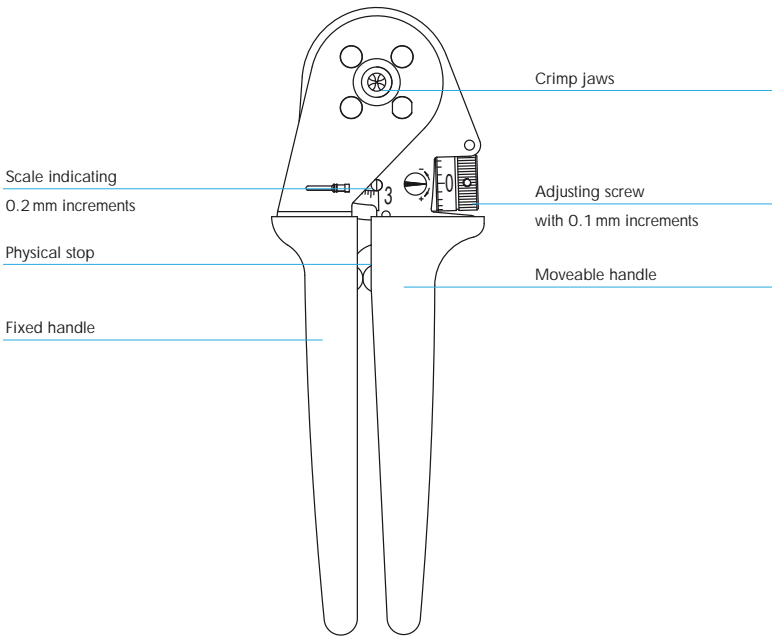
Crimp Tool	Type	Part Number
	<p>Crimp tool7.000.900.901</p> <p>Application The four indent crimp tool 7.000.900.901 has been developed for optimal crimping of machined contacts with diameters from 0.14 to 6.0 mm² (26 through 10 AWG).</p> <p>How to Crimp The reference table indicates the correct locator position to be selected and the crimp depth to be adjusted for the contact to be crimped. The contact is then inserted through the access hole of the tool on the opposite side of the locator. The contact is held in place by closing the handles to the first lock-in position thus preventing the contact from falling out of the tool and facilitating insertion of the wire into the contact. The precision ratchet assures consistently accurate crimping every time by forcing the tool to be closed all the way completing the crimping cycle before the tool can be opened again.</p> <p>Exchange of the Locator The locator can be exchanged by removing the socket head cap screw with a socket wrench. It can then be disassembled from the hex head screw by turning it counter-clockwise.</p>	 <p>Crimp jaws</p> <p>Scale indicating 0.2 mm increments</p> <p>Physical stop</p> <p>Fixed handle</p> <p>Adjusting screw with 0.1 mm increments</p> <p>Moveable handle</p>

Crimp Tool

Adjustment of Crimp Depth

Crimp depth can be adjusted as follows:

Turn the adjusting screw clockwise for reducing the crimp depth and counter-clockwise for increasing the crimp depth.

Adjustment Increments:

- 1 space on the adjusting screw $\hat{=}$ adjustment by 0.01 mm
- 1 full rotation of adjusting screw $\hat{=}$ adjustment by 0.2 mm (indication on the screw as well as on the rough scale)
- 5 rotations of the adjusting screw $\hat{=}$ adjustment by 1 mm (indication on the scale)

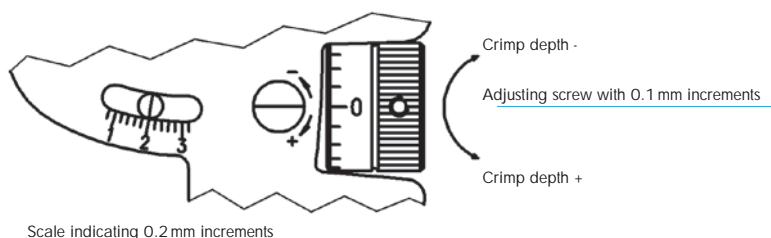

Control of Crimp Depth

Crimp tool adjustment is done at the factory, but with frequent use, periodic calibration is recommended to insure accuracy. This is easily accomplished with a 2.0 mm \varnothing wire gauge as follows.

A crimp depth of 2.0 mm is set by means of the adjusting screw (scale mark at „2“, screw mark at „0“ as shown in the fig. above) and the tool in the closed position. After insertion of the gauge, there must be just enough space for moving the gauge inside the entry hole. If the opening is too small or too large to exactly match the gauge, the deviation (+/-) can be checked by the precision setting of the screw. Please contact the factory in case the deviation exceeds the tolerances specified by the contract manufacturer.

Maintenance and Repair

Keep the tool clean and properly stored when not in service. All pivot points need to be oiled regularly and the spring clips securing the bolts have to always be in place. For repair please send the tool back to the factory.

Crimp Tool for Power Connectors M 23

Crimp Tool Setting for HUMMEL Crimp Contacts (Crimp Tool 7.000.900.901)

Part Number	Crimp Contact	Cross Section mm ²	AWG	Crimp Tool Setting mm	Locator Setting
7.010.901.001	Crimp pin (signal) 1 mm	0,14	26	0,75	11
		0,25	24	0,82	11
		0,35	22	0,9	11
		0,50	20	1	11
		0,75	18	1,08	11
		1,0	17	1,2	11
7.010.901.012	Crimp socket (signal) 1 mm	0,14	26	0,75	12
		0,25	24	0,8	12
		0,35	22	0,87	12
		0,50	20	0,97	12
7.010.901.002	Crimp socket (signal) 1 mm	0,50	20	0,95	12
		0,75	18	1	12
		1,0	17	1,05	12
7.010.901.501	Crimp pin (signal) 1,5 mm	0,14	26	0,75	3
		0,25	24	0,82	3
		0,35	22	0,9	3
		0,50	20	0,96	3
		0,75	18	1,03	3
		1,0	17	1	3
7.010.901.512	Crimp socket (signal) 1,5 mm	0,14	26	0,75	4
		0,25	24	0,8	4
		0,35	22	0,87	4
		0,50	20	0,97	4
7.010.901.502	Crimp socket (signal) 1,5 mm	0,50	20	0,95	4
		0,75	18	1	4
		1,0	17	1,05	4
7.010.902.001	Crimp pin (signal) 2 mm	0,75	18	1,3	5
		1,0	17	1,4	5
		1,5	16	1,55	5
		2,5	14	1,75	5
7.010.902.002	Crimp socket (signal) 2 mm	0,75	18	1,3	6
		1,0	17	1,4	6
		1,5	16	1,55	6
		2,5	14	1,75	6
7.010.941.001	Crimp pin (power) 1 mm	0,14	26	0,75	1
		0,25	24	0,8	1
		0,35	22	0,85	1
		0,50	20	1,03	1
		0,75	18	1,08	1
		1,0	17	1,13	1

Crimp Tool for Power Connectors M 23

Crimp Tool Setting for HUMMEL Crimp Contacts					
Part Number	Crimp Contact	Cross Section mm ²	AWG	Crimp Tool Setting mm	Locator Setting
7.010.941.002	Crimp socket (power) 1 mm	0,14	26	0,75	2
		0,25	24	0,8	2
		0,35	22	0,85	2
		0,50	20	0,89	2
		0,75	18	0,95	2
		1	17	1,02	2
7.010.942.001	Crimp pin (power) 2 mm	0,75	18	1,2	7
		1	17	1,4	7
		1,5	16	1,55	7
		2,5	14	1,7	7
7.010.942.011	Crimp pin (power) 2 mm	2,5	14	1,47	7
		4	12	1,6	7
7.010.942.002	Crimp socket (power) 2 mm	0,75	18	1,2	8
		1	17	1,4	8
		1,5	16	1,55	8
		2,5	14	1,7	8
7.010.942.002	Crimp socket (power) 2 mm	2,5	14	1,47	8
		4	12	1,6	8

These values are only guidelines and actual conductor cross sections depend on manufacturer tolerances.
Please see assembly instructions on page 126

Power Connectors M 23 / Assembly Instructions

Straight Connector, Female Thread

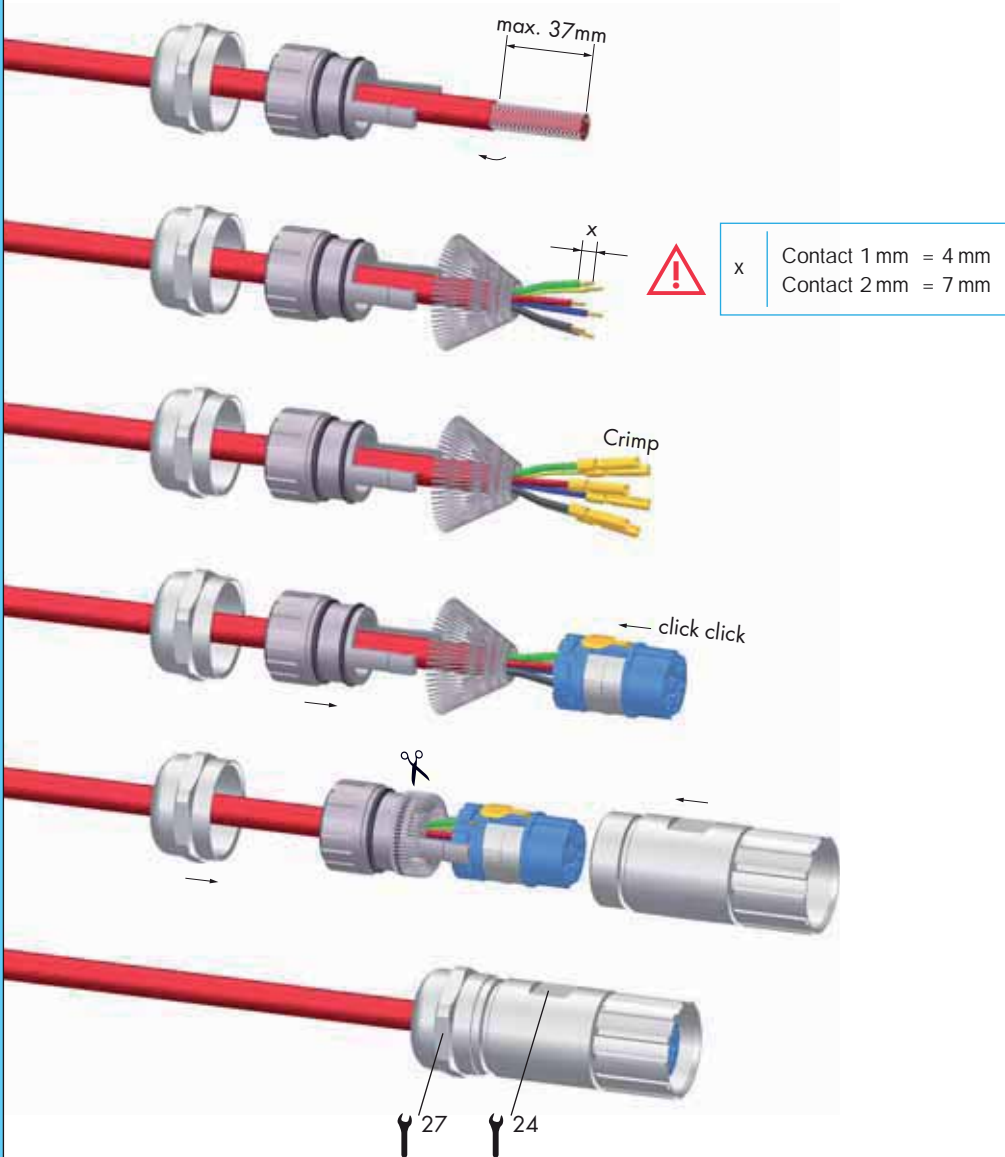

Panel Connector, Male Thread

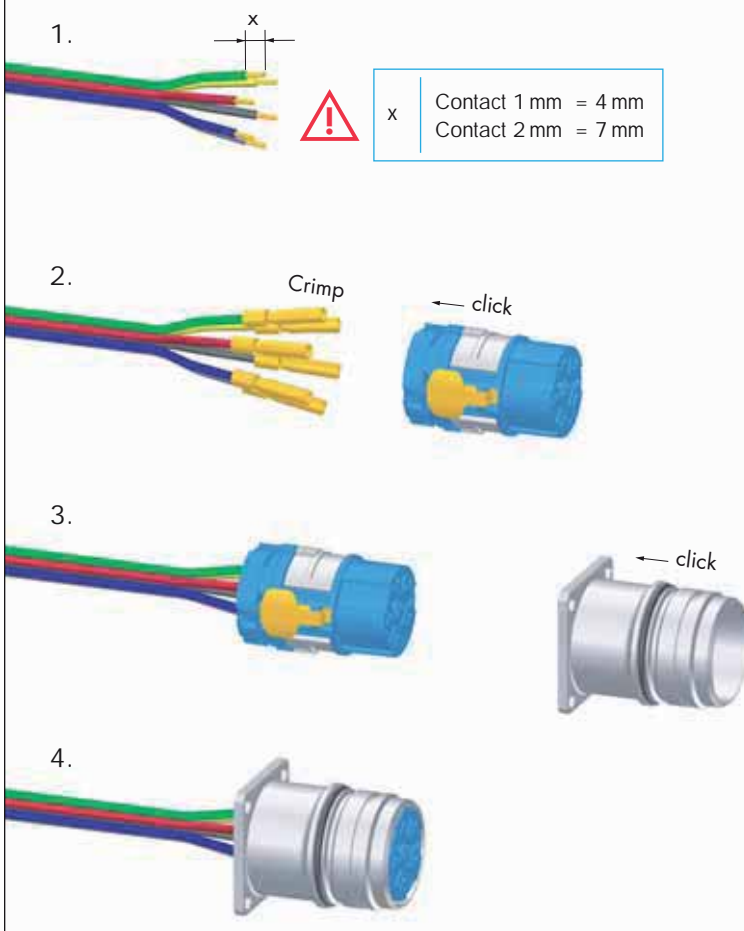

Right Angle Connector with positioning

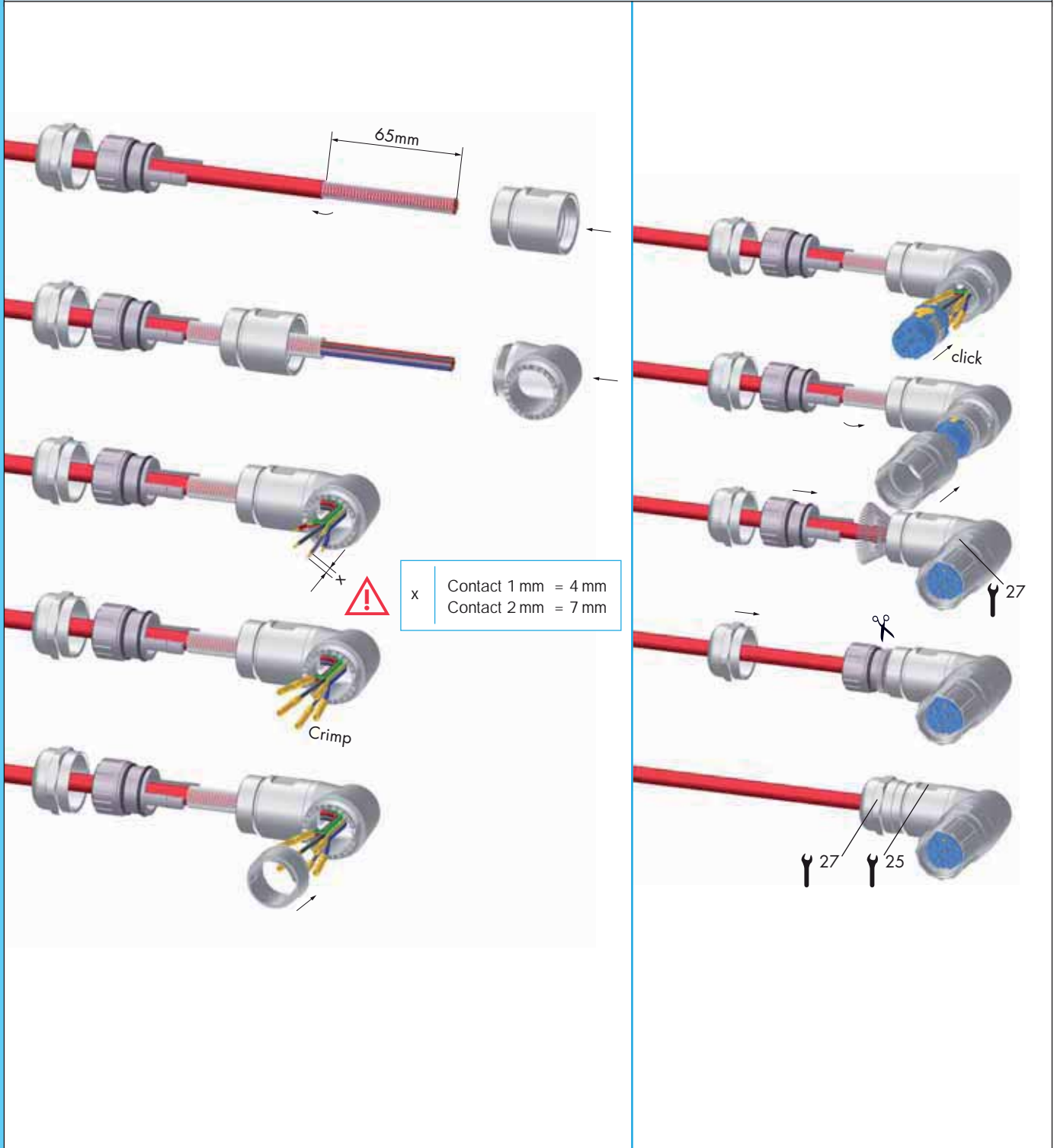

Panel Connector. Female Thread

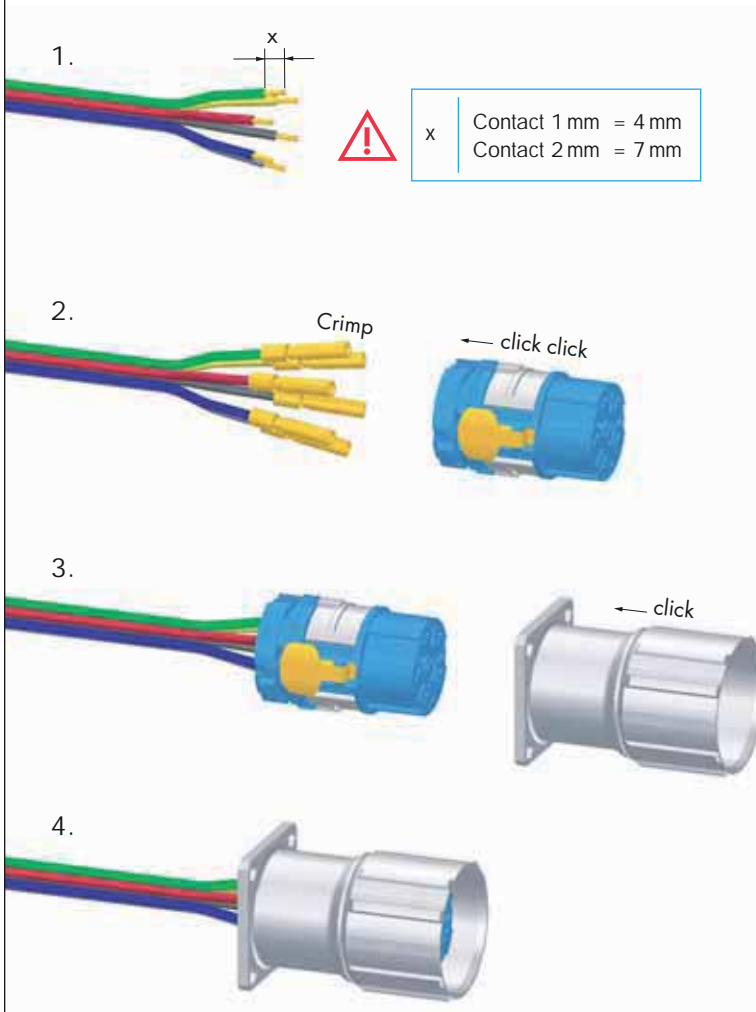

Panel Connector, Male Thread, Single Hole Mounted

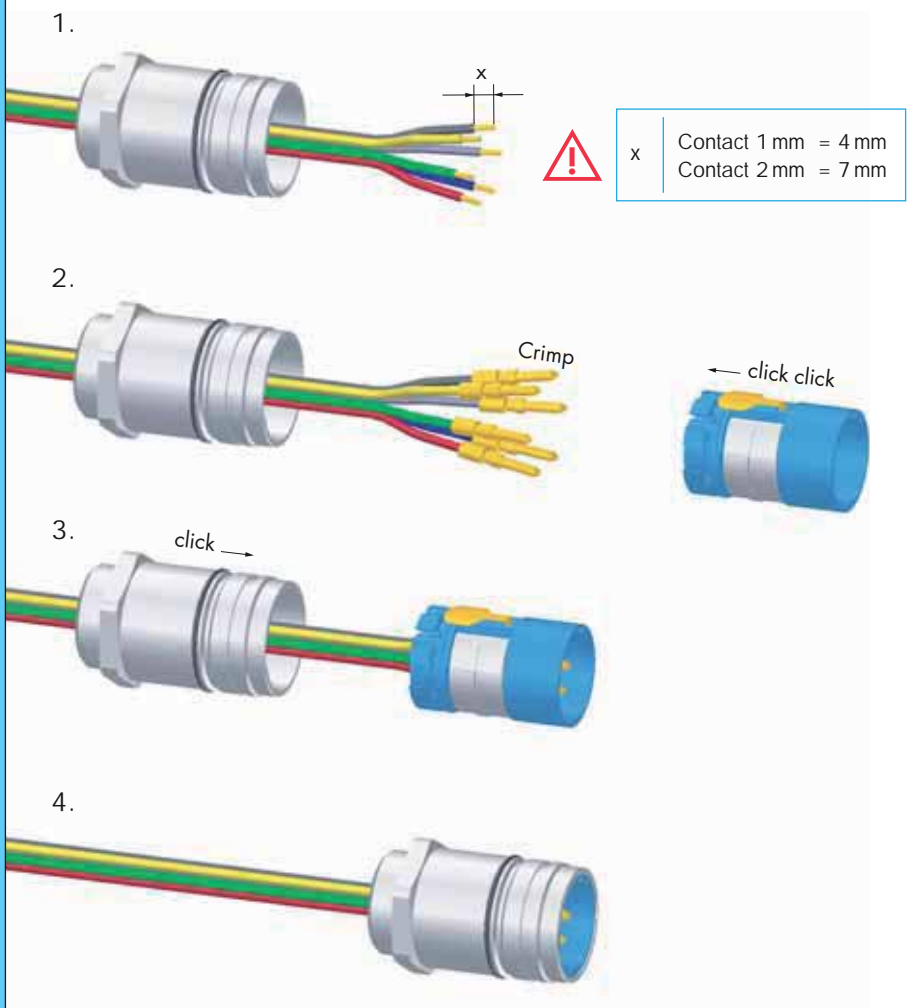

Right Angle Panel Connector

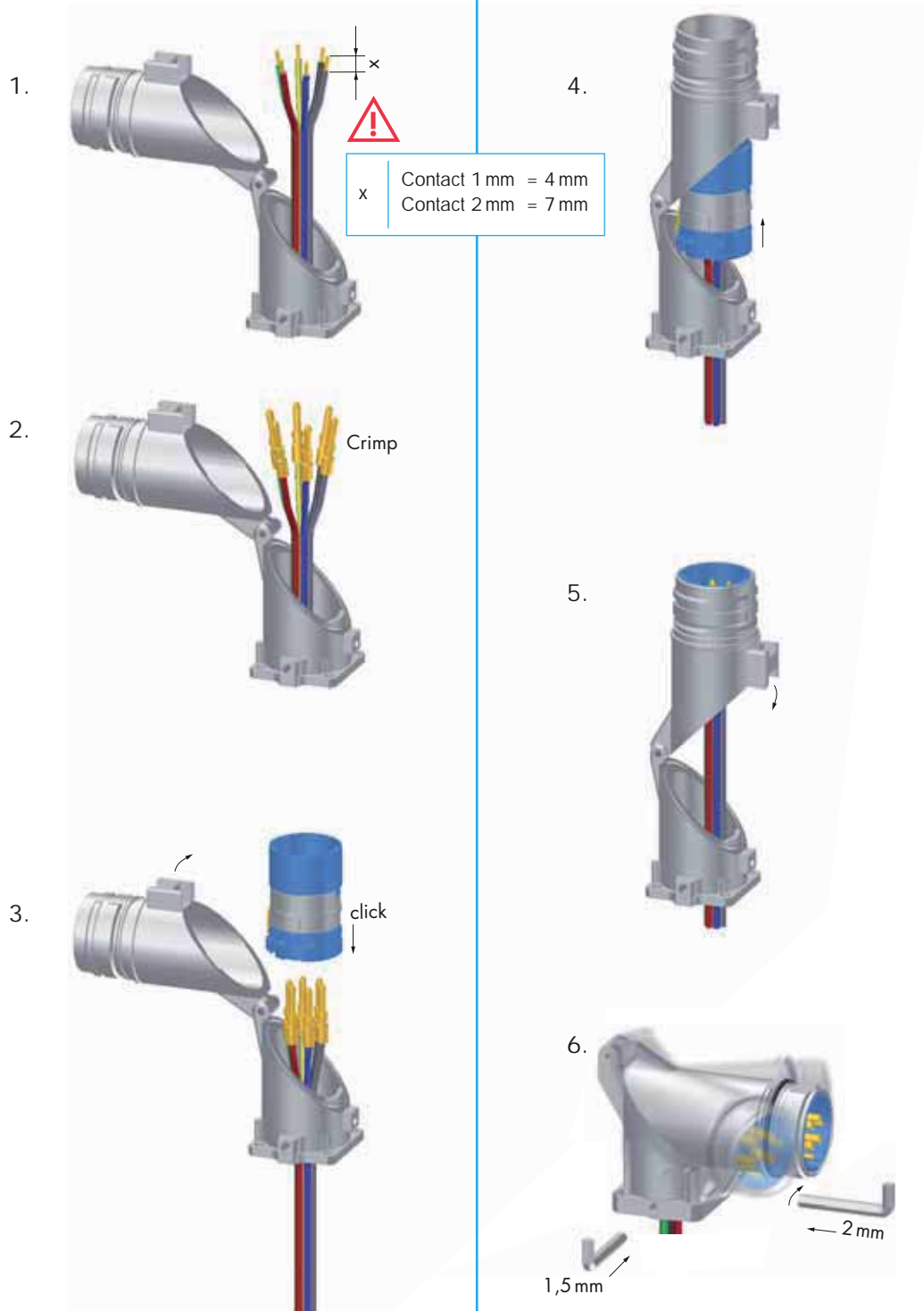

Crimping, Assembly and Disassembly

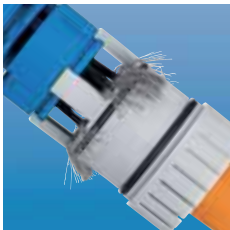
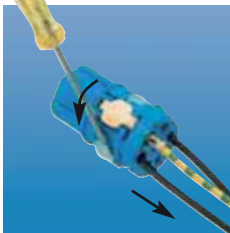
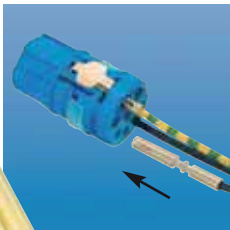
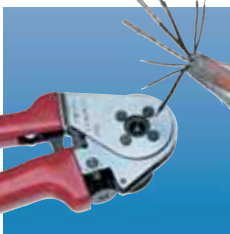

Crimping

- For 1 mm contacts strip wire ends 4 mm (.16") max., for 2 mm contacts strip wire ends 7 mm (.28") max.
- Dial appropriate setting of crimping tool (page 118 / 119)
- Push crimp contact into opening of crimping tool
- Insert stripped wire into the funnel shaped end of the crimp contact
- Squeeze handles of crimping tool together, connecting contact to wire

Assembly

- Remove crimped assembly and pull on wire to test connection
- Push into desired position of insert
Note: For 8-pole inserts (4 + 3 + PE) it is recommended to assemble the large contacts first.

Disassembly of Contacts from Insert

A small screw driver is required.

- Using the screw driver, push the white clip ring out of the insert
- Pull the contacts out of the insert
- Replace the white clip ring
- Re-insert the contacts

Disassembly of Insert from Housing

A small screw driver is required. Push locking tongue, located above the PE-contact, down. By simultaneously pushing on the front side of the insert, it can be disassembled from the housing.

Shielding

- Assemble strain relief insert with insert
- Fold stranding of the shield back over the first O-Ring of the strain relief insert
- Cut back the overextending braid

The stranding of the shield is not allowed to touch the second O-Ring. Otherwise the assembly may not be proof.

Power Connectors Size 1,5 (M 40)



Housings

page 130



Inserts

page 133

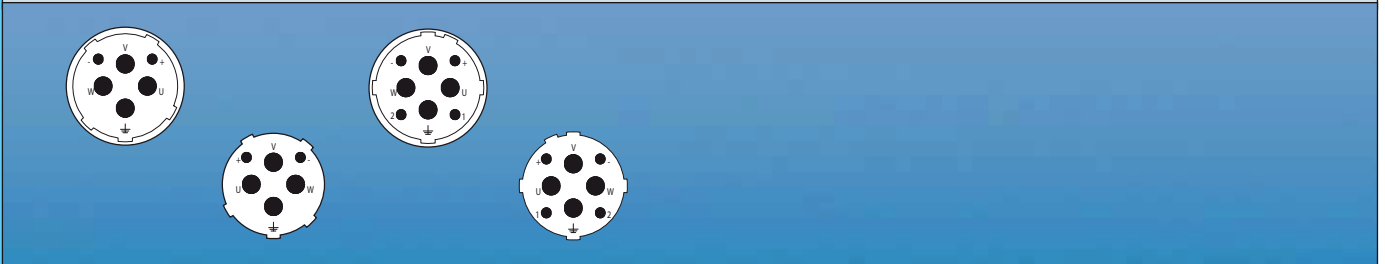

Accessories

page 136



Power Connectors Size 1,5 (M 40)

Mechanical Data	Materials and Technical Data
Housing	Copper-Zinc alloy Die Casting Aluminium alloy
Housing surface	Nickel plated brass (standard), other surface upon request
Inserts (for contacts)	Thermoplastic Polyamid PA 6 (Nylon 6/6), PBT Fire protection class V-0
Contacts	Brass Alloy
Contact surface at point of contact	Nickel and gold plated (0,25 µm Au)
Minimum mating cycles	> 500
Seals / O-Rings	Buna-N standard optional Viton® (Viton is a registered trademark of DuPont)
Temperature range	-40° C – 125° C (-40 °F – 257 °F)
Type of contacts	Crimp
Protection	IP 67 / IP 69 K per EN 60 529 (connected), NEMA 4x
Cable diameter range	13 – 28 mm (.51" – 1.10")

Electrical Data	3 + 2 + PE		4 + 3 + PE	
Number of positions				
Number of contacts	2	4	4	4
Contact-Ø [mm]	2	3,6	2	3,6
Nominal current ¹⁾ [A]	28	55	28	55
Nominal voltage ²⁾ [V~] Degree of Protection 2 ³⁾	300	800	300	800
Nominal voltage ²⁾ [V~] Degree of Protection 3 ³⁾	300	600	300	600
Test voltage (Breakdown voltage) ⁴⁾ [V~]	2500	4000	2500	4000
Insulation resistance [mΩ]	> 10 ¹³		> 10 ¹³	
Max. contact resistance) [mΩ]	3	1	3	1

¹⁾, ²⁾, ³⁾, ⁴⁾ See Technical Informations page 14

Derating

Straight connectors male + female,
wires 3 x AWG 6

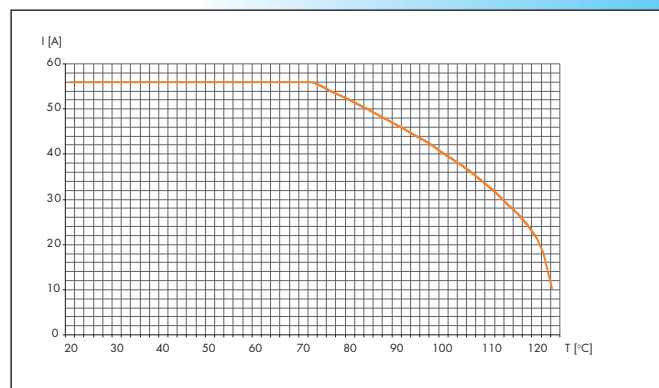

 Standard delivery of M 40 (size 1.5) Power Connector include Contact Insert

Power Connectors Size 1,5 (M 40)

Straight Connector, Female Thread		Cable-Ø	Part Number
			2 + 3 + PE, insert for sockets 13 - 18 mm (.51 - .71")7.710.623.000 17 - 24 mm (.67 - .97")7.710.723.000 21 - 28 mm (.83 - 1.10") ...7.710.823.000
			Contacts page 134 • Assembly instructions page 143

Straight Connector, Female Thread		Cable-Ø	Part Number
			4 + 3 + PE, insert for sockets 13 - 18 mm (.51 - .71")7.710.643.000 17 - 24 mm (.67 - .97")7.710.743.000 21 - 28 mm (.83 - 1.10") ...7.710.843.000
			Contacts page 134 • Assembly instructions page 143

Straight Connector, Male Thread		Cable-Ø	Part Number
			2 + 3 + PE, insert for pins 13 - 18 mm (.51 - .71")7.720.623.000 17 - 24 mm (.67 - .97")7.720.723.000 21 - 28 mm (.83 - 1.10") ...7.720.823.000
			Contacts page 134 • Assembly instructions page 143

Straight Connector, Male Thread		Cable-Ø	Part Number
			4 + 3 + PE, insert for pins 13 - 18 mm (.51 - .71")7.720.643.000 17 - 24 mm (.67 - .97")7.720.743.000 21 - 28 mm (.83 - 1.10") ...7.720.843.000
			Contacts page 134 • Assembly instructions page 143

Power Connectors Size 1,5 (M 40)

Cable-Ø	Part Number	Panel Connector, Male Thread, Front Mounting			
2 + 3 + PE, insert for pins 4 holes Ø 4,5 mm (.18") 7.740.023.000					
Contacts page 134 • Assembly instructions page 144					

Cable-Ø	Part Number	Panel Connector, Male Thread, Front Mounting			
4 + 3 + PE, insert for pins 4 holes Ø 4,5 mm (.18") 7.740.043.000					
Contacts page 134 • Assembly instructions page 144					

Cable-Ø	Part Number	Panel Connector with knurled Nut, Front Mounting			
2 + 3 + PE, insert for sockets 4 holes Ø 4,5 mm (.18") 7.744.023.000					
Contacts page 134 • Assembly instructions page 144					

Cable-Ø	Part Number	Panel Connector with knurled Nut, Front Mounting			
4 + 3 + PE, insert for sockets 4 holes Ø 4,5 mm (.18") 7.744.043.000					
Contacts page 134 • Assembly instructions page 144					

Power Connectors Size 1,5 (M 40)

Right Angle Panel Connector, Male Thread, rotating		Type	Part Number
		2 + 3 + PE, insert for pins 4 holes Ø 4,5 mm (.18") 7.743.023.000	
			Contacts page 134 • Assembly instructions page 145

Right Angle Panel Connector, Male Thread, rotating		Type	Part Number
		4 + 3 + PE, insert for pins 4 holes Ø 4,5 mm (.18") 7.743.043.000	
			Contacts page 134 • Assembly instructions page 145



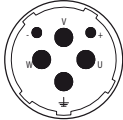
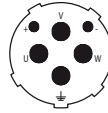
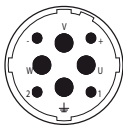
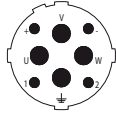

Panel Connector, Male Thread, Single Hole Mounted		Type	Part Number
		Front mounting, 2 + 3 + PE, insert for pins Thread M 40 x 1,5 7.742.023.000	
			Contacts page 134 • Assembly instructions page 144

Panel Connector, Male Thread, Single Hole Mounted		Type	Part Number
		Front mounting, 4 + 3 + PE, insert for pins Thread M 40 x 1,5 7.742.043.000	
			Contacts page 134 • Assembly instructions page 144

Power Connectors Size 1,5 (M 40) / Required Contacts

	Type of Contact	Contact Arrangement, Mating View
Insert for pins 2 + 3 + PE.....	2 x crimp pins 2 mm 4 x crimp pins 3,6 mm	
Insert for sockets 2 + 3 + PE	2 x crimp sockets 2 mm 4 x crimp sockets 3,6 mm	
Insert for pins 4 + 3 + PE.....	4 x crimp pins 2 mm 4 x crimp pins 3,6 mm	
Insert for sockets 4 + 3 + PE	4 x crimp sockets 2 mm 4 x crimp sockets 3,6 mm	

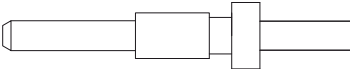
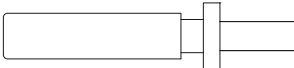
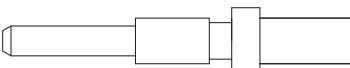
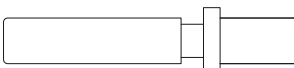
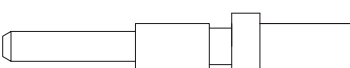
Power Connectors Size 1,5 (M 40) / Contacts

Contacts	Type of Contact	Crimp Range	Part Number
	Crimp pin 2 mm, machined0,5 – 4 mm ² (AWG 20 – 12)7.015.952.001
	Crimp socket 2 mm, machined	...0,5 – 4 mm ² (AWG 20 – 12)7.015.952.002
	Crimp pin 3,6 mm, machined1,5 – 4 mm ² (AWG 16 – 12)7.015.953.601
	Crimp socket 3,6 mm, machined	..1,5 – 4 mm ² (AWG 16 – 12)7.015.953.602
	Crimp pin 3,6 mm, machined6 mm ² (AWG 10)7.015.953.611
	Crimp socket 3,6 mm, machined	..6 mm ² (AWG 10)7.015.953.612
	Crimp pin 3,6 mm, machined10 mm ² (AWG 8)7.015.953.621
	Crimp socket 3,6 mm, machined	..10 mm ² (AWG 8)7.015.953.622



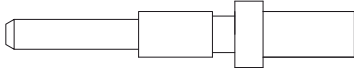
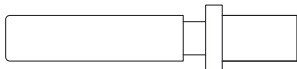

For appropriate setting of crimp tool see page 146

Power Connectors Size 1,5 (M 40) / Contacts



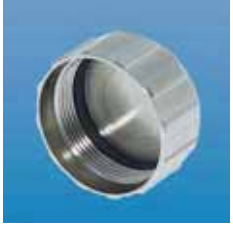

Type	Part Number	Contacts
Crimp pin 3,6 mm, machined 16 mm ² (AWG 6)	7.015.953.631	
Crimp socket 3,6 mm, machined .. 16 mm ² (AWG 6)	7.015.953.632	

For appropriate setting of crimp tool see page 146

Power Connectors Size 1,5 (M 40) / Accessories

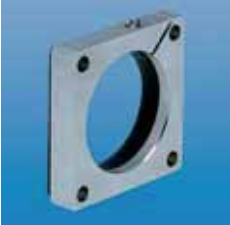
Accessories	Type	Part Number
	Plastic protective cap for connectors with female thread	7.000.900.152
	Plastic protective cap for connectors with male thread	7.000.900.151
	Brass protective cap for connectors with female thread	7.015.900.103
	Brass protective cap for connectors with male thread	7.015.900.102
	Brass protective cap with chain for connectors with female thread	7.015.9S1.003
	Brass protective cap with chain for connectors with male thread	7.015.9S1.002

Power Connectors Size 1,5 (M 40) / Accessories

Type	Part Number	Accessories
Adaptor flange for Straight Connectors	7.010.900.129	
Adapter for Conduit Fittings		
Crimp tool for manual crimping of machined crimp contacts up to 10 mm ² (AWG 8) for power connectors	7.000.900.902	
See page 139 / 139 for crimp tool instructions and page 142 for proper setting		
Crimp tool for manual crimping of machined crimp contacts 16 mm ² (AWG 6)	7.000.900.903	
See page 140 / 141 for crimp tool instructions and page 142 for proper setting		

Crimp Tool for Power Connectors Size 1,5 (M 40)

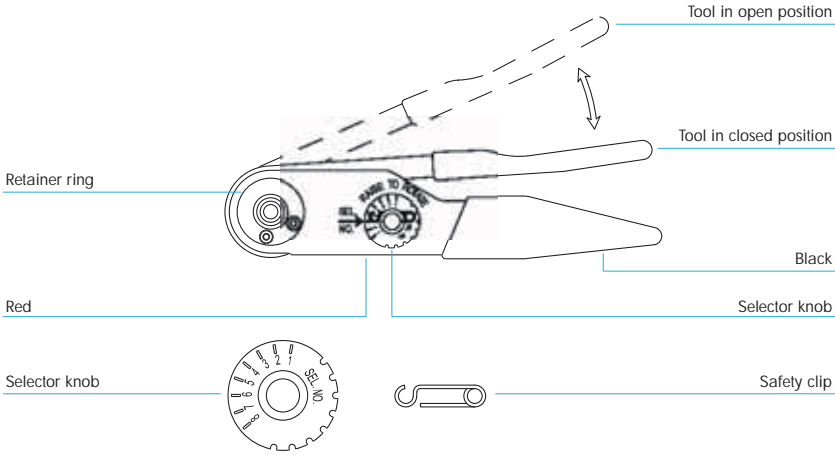
Crimp Tool	Type	Part Number
	<p>Crimp tool7.000.900.902</p> <p>Application The four indent crimp tool 7.000.900.902 has been developed for optimal crimping of machined contacts with diameters from 1 to 10 mm² (18 through 8 AWG).</p> <p>How to Crimp The reference table indicates the correct locator position to be selected and the crimp depth to be adjusted for the contact to be crimped. The contact is then inserted through the access hole of the tool on the opposite side of the locator. The contact is held in place by closing the handles to the first lock-in position thus preventing the contact from falling out of the tool and facilitating insertion of the wire into the contact. The precision ratchet assures consistently accurate crimping every time by forcing the tool to be closed all the way completing the crimping cycle before the tool can be opened again.</p> <p>Exchange of the Locator The locator can be exchanged by removing the socket head cap screw with a socket wrench. It can then be disassembled from the hex head screw by turning it counter-clockwise.</p>	

Setting Up Instructions

1. Tool must be in open position
2. Place selected single position head assembly onto retainer ring with alignment pin in alignment pin hole
3. After single position head is seated against retainer ring, tighten socket head screws with 9/64 inch socket head screw key
4. Refer to dataplate on single position head. From the proper wire size column, determine the selector number that corresponds with the contact being used
5. Remove spring clip lock wire from selector knob. Raise selector knob and rotate until selector number is in line with index mark. Replace spring clip lock wire (optional)

Crimping Instructions

1. Insert contact and prepared wire through the indenter opening into positioner
2. Squeeze handles together until ratchet releases. Handle will return to open position. Remove crimped contact and wire

Removing Single Position Head

Loosen socket head screws until threads are disengaged from retainer ring and remove with a straightlifting motion

Gaging Instructions

The correct function of the crimp tool has to be checked with a gage (item no. 7.010.900.117).

„GO“-Gaging (green)

Operate tool to fully closed position. Maintain firm hand pressure on the tool handles. Insert „GO“ gage end. Gage must pass freely between indenter tips.

„NO-GO“-Gaging (red)

Operate tool to fully closed position. Maintain firm hand pressure on the tool handles. Insert „NO-GO“ gage end. The „NO-GO“ gage may partially enter the indenter opening, but must not pass completely through the opening.

Care of Tool

There is virtually no maintenance required. However, it is a good practice to keep indenter tips free of residual color band deposits and other debris. A small wire brush may be used for this purpose.

We strongly recommend that you:

1. Do not immerse tools in cleaning solution
2. Do not spray oil into tool to lubricate
3. Do not attempt to disassemble tool or make repairs

This is a precision crimp tool and should be handled as such.

Crimp Tool for Power Connectors Size 1,5 (M 40)

Crimp Tool	Type	Part Number
	<p>Crimp tool for contacts 16 mm² (AWG 6) 7.000.900.903</p> <p>Application The hand crimp tool 7.000.900.903 has been developed for optimal crimping of a large variety of connectors and terminals by using different interchangeable crimping dies.</p> <p>Operation</p> <ul style="list-style-type: none"> - Select crimp insert and install in tool - Insert and align crimp contact in tool - Compress tool until contact is held in place - Insert conductor into contact - Fully compress tool (tool will reopen automatically) - Remove crimped conductor from tool 	 <p>Die retaining screws</p> <p>Emergency release</p> <p>Stationary jaw with upper die</p> <p>Movable jaw with lower die</p> <p>Set screw</p> <p>Adjustment wheel</p>

Crimp Tool for Power Connectors Size 1,5 (M 40)

Crimp Tool

Adjustment of crimp force and height

Crimp force adjustment is done in the factory (120 – 180 N when unloaded). Tool frame and jaws are connected that way, an optimal crimping result will be obtained based on the hand force indicated above. In case the result (e.g. crimp height, pull-out force, etc.) does not meet the requirements of the plug manufacturer, the following reasons can be considered:

a) Normal wear of tool

Readjustment possible

b) Worn dies

Dies have to be replaced

The quality personnel is authorized to control and readjust these parameters as described below:

- Unscrew the set screw by means of a screw driver
- Rotating the adjustment wheel anticlockwise, the crimp force increases and the crimp height decreases (+)
- Rotating the adjustment wheel clockwise, the crimp force decreases and the crimp height increases (-)
- When readjusting the hand force shall not exceed 180 N
- Before using the tool, the operator has to check the adjustment wheel being firmly secured by the set screw

Maintenance

Keep the tool clean and properly stored when not in service. The joints need to be regularly oiled and the circlips securing the bolts have to be always in place. Never use abrasives or hard material to clean the jaws. Please contact the manufacturer when the tool needs to be repaired or in case of readjustment problems.



Crimp Tool for Power Connectors Size 1,5 (M 40)

Crimp Tool Setting for HUMMEL Crimp Contacts (Crimp Tool 7.000.900.902)

Part Number	Contact	Cross Section mm ²	AWG	Crimp Tool Setting mm	Locator Setting
7.015.952.001	Crimp pin 2 mm	1	17	2	3
		1,5	16	3	3
		2,5	14	4	3
		4	12	4	3
7.015.952.002	Crimp socket 2 mm	1	17	2	1
		1,5	16	3	1
		2,5	14	4	1
		4	12	4	1
7.015.953.601	Crimp pin 3,6 mm	1,5	16	3	2
		2,5	14	4	2
		4	12	5	2
7.015.953.602	Crimp socket 3,6 mm	1,5	16	3	4
		2,5	14	4	4
		4	12	5	4
7.015.953.611	Crimp pin 3,6 mm	6	10	5	2
7.015.953.612	Crimp socket 3,6 mm	6	10	5	4
7.015.953.621	Crimp pin 3,6 mm	10	8	7	2
7.015.953.622	Crimp socket 3,6 mm	10	8	7	4

These values are only guidelines and actual conductor cross sections depend on manufacturer tolerances.
 Assembly information see page 146

Crimp Tool Setting for HUMMEL Crimp Contacts (Crimp Tool 7.000.900.903)

Part Number	Crimp Contact	Cross Section mm ²	AWG	Crimp Tool Setting
7.015.953.631	Crimp pin 3,6 mm	16	6	die 16
7.015.953.632	Crimp socket 3,6 mm	16	6	die 16

These values are only guidelines and actual conductor cross sections depend on manufacturer tolerances.
 Assembly information see page 146

Power Connectors Size 1,5 (M 40) / Assembly Instructions

Straight Connector, Female Thread

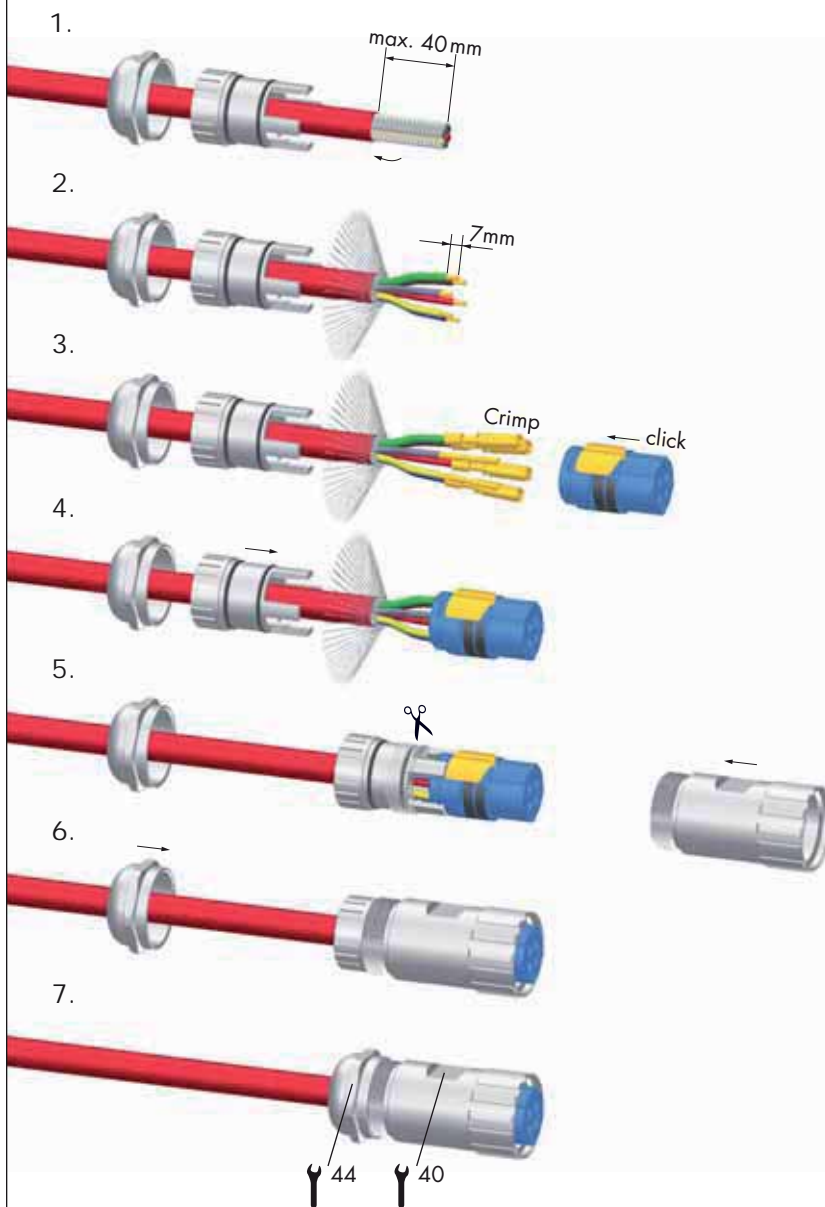

Panel Connector

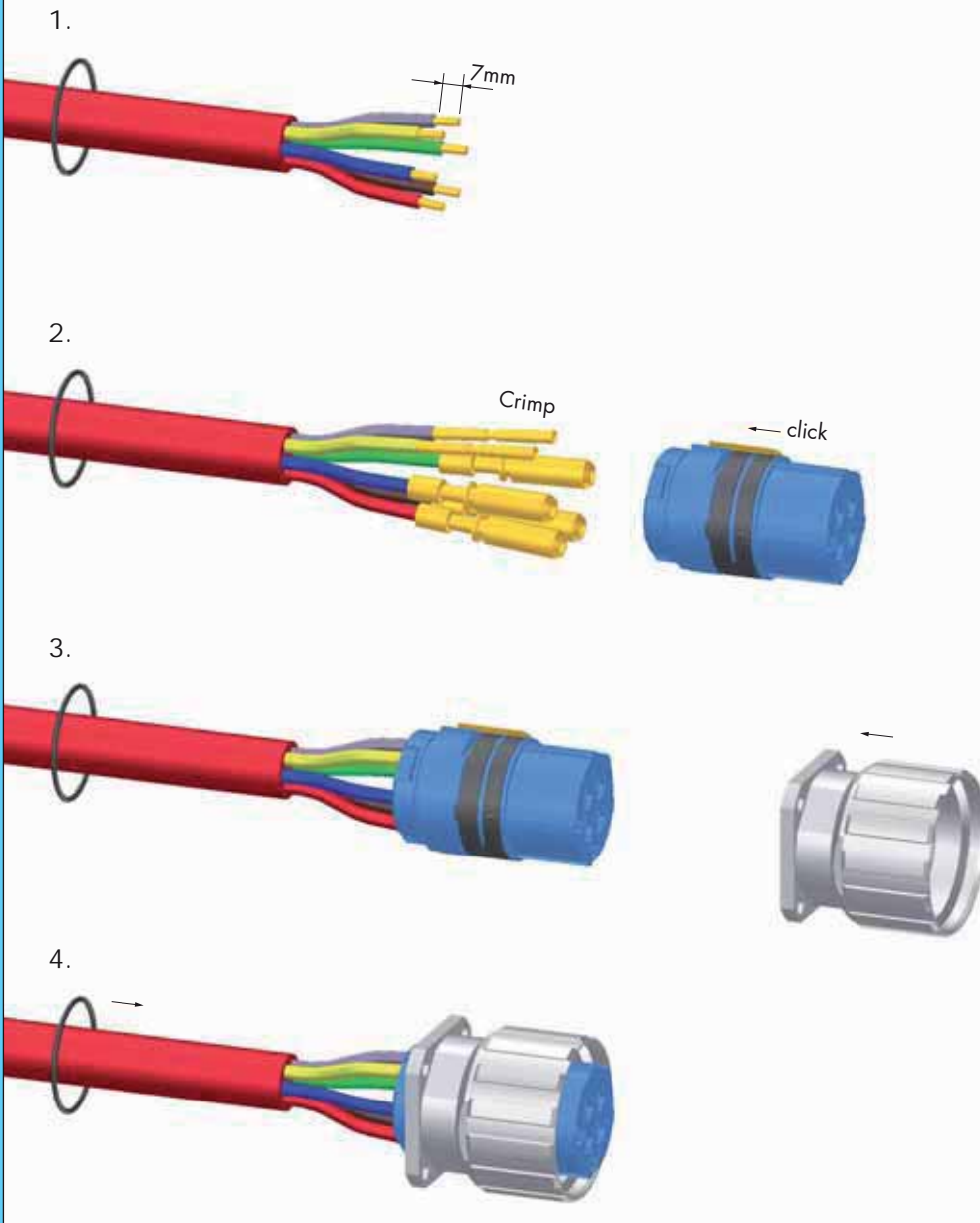

Power Connectors Size 1,5 (M 40) / Assembly Instructions

Right Angle Panel Connector

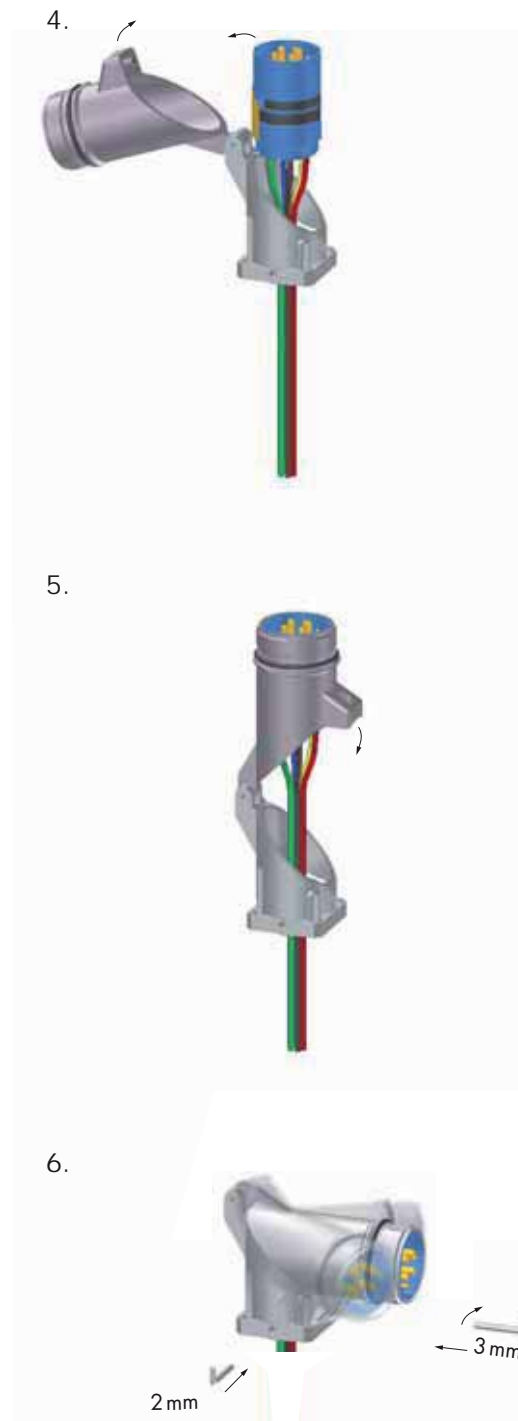
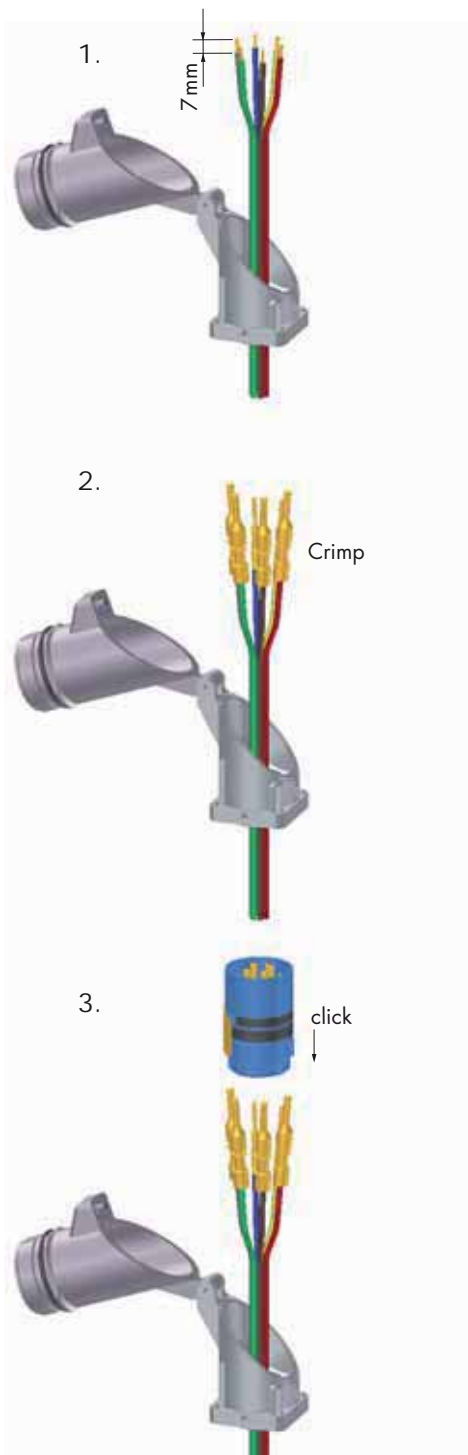

Crimping, Assembly and Disassembly

Crimping, Assembly and Disassembly



Crimping

- Strip wire ends 7 mm (.28")
- Dial appropriate setting of crimp tool (page 142)
- Push crimp contact into opening of crimping tool
- Insert stripped wire into the funnel shaped end of the crimp contact
- Squeeze handles of crimping tool together connect contact to wire



Assembly

- Remove crimped assembly and pull on wire to test connection
- Push into desired position of insert
Note: It is recommended to assemble the large contacts first.

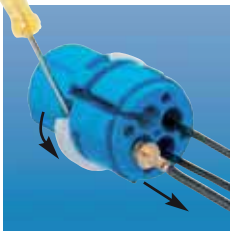

Disassembly of Contacts from Insert

A small screwdriver is needed to remove the contacts from the insert.

- Release the white ring by a screwdriver out of the insert
- Move the misplaced contacts out of the insert
- Enter the ring back into the insert
- Push the contacts back into insert

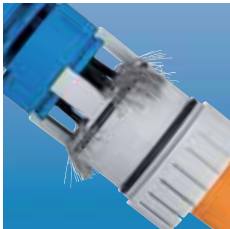

Shielding

- Assemble strain relief insert with insert
- Fold stranding of the shield back over the first O-Ring of the strain relief insert
- Cut back the overextending braid

 The stranding of the shield is not allowed to touch the second O-Ring. Otherwise the assembly may not be proof.

Push-Pull Technology



Housings

page 104



Inserts

page 22, 51, 72, 112, 130

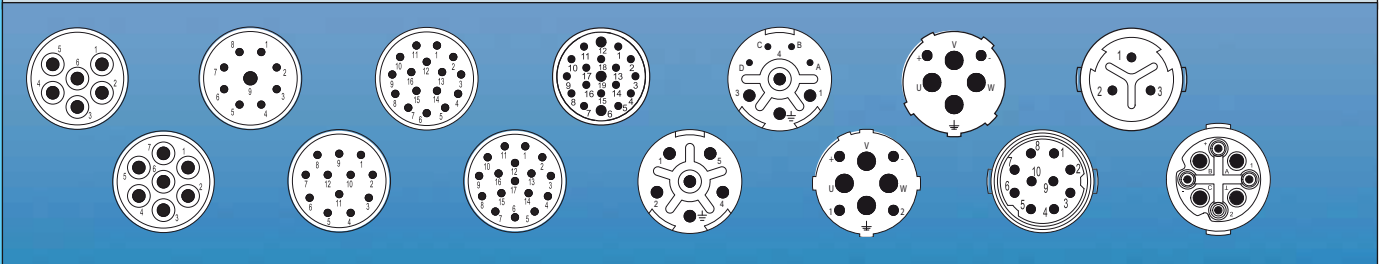

Accessories

page 26, 57, 80, 114, 136



Push-Pull Connectors

Mechanical Data	Materials and Technical Data
Housing	Copper-Zinc alloy Die Casting Aluminium alloy
Housing surface	Nickel plated brass (standard), other surface upon request
Inserts (for contacts)	Thermoplastic Polyamid PA 6 (Nylon 6/6), PBT Fire protection class V-0
Contacts	Brass Alloy
Contact surface at point of contact	Nickel and gold plated (0,25 µm Au)
Minimum mating cycles	> 250
Seals / O-Rings	Buna-N standard optional Viton® (Viton is a registered trademark of DuPont)
Temperature range	-40° C – 125° C (-40 °F – 257 °F)
Type of contacts M 16	Crimp, dip-solder (PCB)
Type of contacts signal M 23	Crimp, solder, dip-solder (PCB)
Type of contacts power M 23, M 40	Crimp
Protection	IP 67 / IP 69K per EN 60 529 (connected), NEMA 4x

Additional Information

Electrical data see standard program

Connectors M 16	page 17
Signal Connectors M 23	page 63
Power Connectors M 23	page 105
Power Connectors Size 1,5	page 129

Inserts and contacts see standard program

Connectors M 16	page 22
Signal Connectors M 23	page 72
Power Connectors M 23	page 112
Power Connectors Size 1,5	page 130



We do not recommend disconnecting or connecting HUMMEL Connectors under load.

Characteristics

HUMMEL Push-Pull Connectors guarantee:

- Quick connecting cycle
- EMC compatible connection due to radially locked metal ring
- High protection rate
- Easy connection / disconnection even under tight space conditions
- Best reliability with optional safety ring



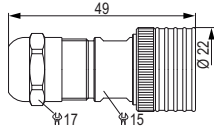

Standard delivery of M 40 (size 1.5) Power Connector include Contact Insert

M 16 Signal Connectors / Push-Pull

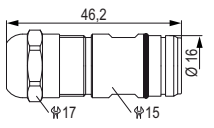
Straight Connector, Female Thread	Cable-Ø	Part Number
	2 – 7 mm (.08 – .28") 4 – 9 mm (.16 – .35")7.813.300.0007.813.400.000
	Optional: Safety ring	Contacts and inserts page 22 • Assembly instructions page 32

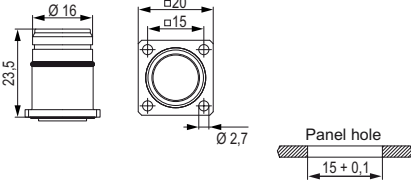
Straight Connector, Male Thread	Cable-Ø	Part Number
	2 – 7 mm (.08 – .28") 4 – 9 mm (.16 – .35")7.823.300.0007.823.400.000
	Contacts and inserts page 22 • Assembly instructions page 32 / 33	

Panel Connector, Male Thread	Cable-Ø	Part Number
	4 holes Ø 2,7 mm (.11")7.840.300.000
	Contacts and inserts page 22 • Assembly instructions page 36	

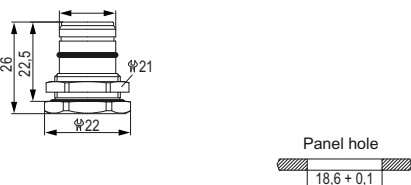
Panel Connector, Male Thread	Cable-Ø	Part Number
	Rear mounting, single hole mounted Including jam nut7.850.300.000
	Contacts and inserts page 22 • Assembly instructions page 36	

Signal Connectors M 23/ Push-Pull

Cable-Ø	Part Number	Straight Connector, Female Thread	
3 – 7 mm (.12 – .28")	7.156.400.000		
7 – 12 mm (.24 – .47")	7.156.500.000		
10 – 14 mm (.39 – .55")	7.156.600.000		
Optional: Safety ring			
Contacts and inserts page 72 • Assembly instructions page 85			

Cable-Ø	Part Number	Right Angle Connector, Female Thread	
3 – 7 mm (.12 – .28")	7.304.300.000		
5 – 10 mm (.20 – .39")	7.304.400.000		
7 – 12 mm (.24 – .47")	7.304.500.000		
10 – 14 mm (.39 – .55")	7.304.600.000		
Optional: Safety ring			
Contacts and inserts page 72 • Assembly instructions page 86			

Cable-Ø	Part Number	Right Angle Connector, Female Thread, EMC	
3 – 7 mm (.12 – .28")	7.305.300.000		
5 – 10 mm (.20 – .39")	7.305.400.000		
7 – 12 mm (.24 – .47")	7.305.500.000		
10 – 14 mm (.39 – .55")	7.305.600.000		
Optional: Safety ring			
Contacts and inserts page 72 • Assembly instructions page 86			

Signal Connectors M 23 Push-Pull fit to all housings with male thread of the standard series HUMMEL Signal Connectors M 23

Signal Connectors M 23 / Push-Pull

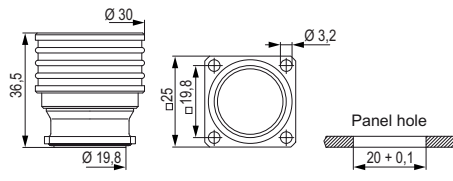
Panel Connector, Female Thread, with knurled Nut		Type	Part Number
		Without coding option	4 holes \varnothing 3,2 mm (.13") 7.440.500.000
		Optional: Safety ring	
		Contacts and inserts page 72 • Assembly instructions page 88	

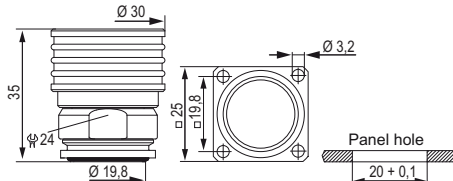
Panel Connector, Female Thread, with knurled Nut		Type	Part Number
		With coding option	4 holes \varnothing 3,2 mm (.13") 7.448.500.000
		Optional: Safety ring	
		Contacts and inserts page 72 • Assembly instructions page 88	

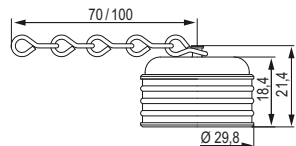
Protective Caps, Push-Pull Signal		Type	Part Number
		For signal connectors with male thread 7.010.950.102
		with chain 100 mm 7.010.95S.102

Signal Connectors M 23 Push-Pull fit to all housings with male thread of the standard series HUMMEL Signal Connectors M 23

Signal Connectors M 23 / Push-Pull

Cable-Ø	Part Number	Straight Connector, Female Thread	
7 – 12 mm (.24 – .47")7.555.500.000		
11 – 17 mm (.43 – .67")7.555.600.000		
Optional: Safety ring			
<small>Contacts and inserts page 112 • Assembly instructions page 120</small>			

Cable-Ø	Part Number	Right Angle Connector, Female Thread ¹⁾	
7 – 12 mm (.24 – .47")7.575.500.000		
10 – 14 mm (.39 – .55")7.575.600.000		
Optional: Safety ring			
<small>Contacts and inserts page 112 • Assembly instructions page 122</small>			

¹⁾ Under development

Power Connectors M 23 Push-Pull fit to all housings with male thread of the standard series HUMMEL Power Connectors M 23

Power Connectors Size 1,5 / Push-Pull

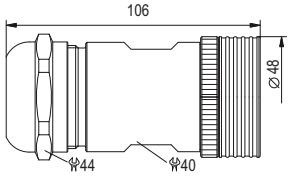
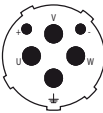
Straight Connector, Female Thread		Cable-Ø	Part Number
			2 + 3 + PE, insert for sockets 13 - 18 mm (.52 - .71").....7.715.623.000 17 - 24 mm (.67 - .95").....7.715.723.000 21 - 28 mm (.83 - 1.10")...7.715.823.000
			Optional: Safety ring Contacts page 134 • Assembly instructions page 143

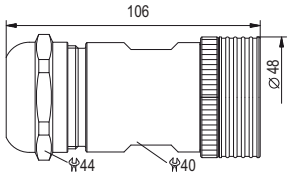
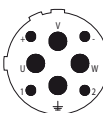
Straight Connector, Female Thread		Cable-Ø	Part Number
			4 + 3 + PE, insert for sockets 13 - 18 mm (.52 - .71").....7.715.643.000 17 - 24 mm (.67 - .95").....7.715.743.000 21 - 28 mm (.83 - 1.10")...7.715.843.000
			Optional: Safety ring Contacts page 134 • Assembly instructions page 143

Power Connectors Size 1,5 / Push-Pull

Cable-Ø	Part Number	Straight Connector, Male Thread	
2 + 3 + PE, insert for pins			
13 – 18 mm (.52 – .71")7.725.623.000		
17 – 24 mm (.67 – .95")7.725.723.000		
21 – 28 mm (.83 – 1.10")	...7.725.823.000		
Contacts page 134 • Assembly instructions page 143			

Cable-Ø	Part Number	Straight Connector, Male Thread	
4 + 3 + PE, insert for pins			
13 – 18 mm (.52 – .71")7.725.643.000		
17 – 24 mm (.67 – .95")7.725.743.000		
21 – 28 mm (.83 – 1.10")	...7.725.843.000		
Contacts page 134 • Assembly instructions page 143			

Panel Connector	Type	Part Number
	2 + 3 + PE, insert for pins 4 holes \varnothing 4,5 mm (.18") 7.740.523.000	
Contacts page 134 • Assembly instructions page 144		

Panel Connector	Type	Part Number
	4 + 3 + PE, insert for pins 4 holes \varnothing 4,5 mm (.18") 7.740.543.000	
Contacts page 134 • Assembly instructions page 144		

Stainless Steel Connectors (INOX)



Housings

page 160



Inserts

page 72, 112

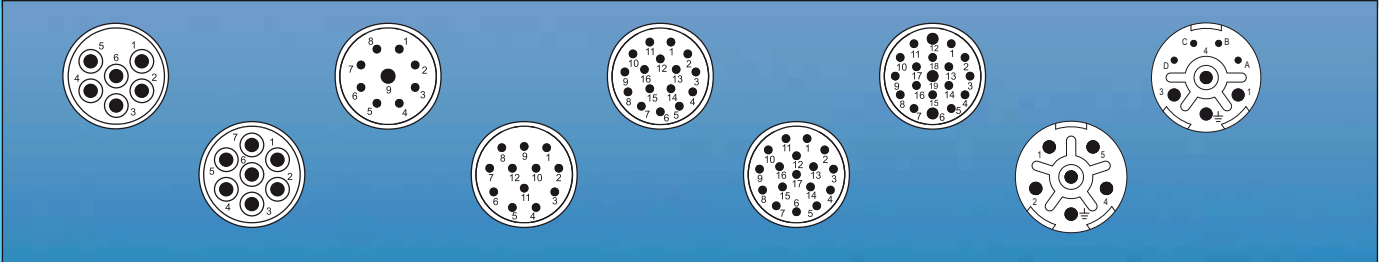

Accessories

page 80, 114



M 23 Connectors Stainless Steel (INOX)

Mechanical Data	Materials and Technical Data	
Housing	Stainless Steel V4A (AISI 316)	1.4404 (AISI 316 L)
Housing surface	Clear	
Inserts (for contacts)	Thermoplastic Polyamid PA 6 (Nylon 6/6), PBT	Fire protection class V-0
Contacts	Brass Alloy	
Contact surface at point of contact	Nickel and gold plated (0,25 µm Au)	
Minimum mating cycles	> 1000	
Seals / O-Rings	Viton (FPM), alternativ EPDM	
Temperature range	-40° C – 125° C	
Type of contacts signal M23	Crimp, solder, dip-solder (PCB)	
Type of contacts power M23	Crimp	
Protection	IP 67 / IP 69 K per EN 60 529 (connected), NEMA 4x	
Cable diameter range signal connectors	3 – 14 mm (.12 – .55")	
Cable diameter range power connectors	7 – 17 mm (.24 – .67")	

Additional Information

Electrical data see standard program

Signal Connectors M23 page 63
 Power Connectors M23 page 105

Inserts and contacts see standard program

Signal Connectors M23 page 72
 Power Connectors M23 page 112

We do not recommend disconnecting or connecting HUMMEL Connectors under load.

Typical Applications

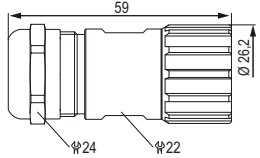

Signal Connectors / Stainless Steel (INOX)

Straight Connector, Female Thread		Cable-Ø	Part Number
		3 – 7 mm (.12 – .28").....	7.140.300.000
		5 – 10 mm (.20 – .39").....	7.140.400.000
		7 – 12 mm (.24 – .47").....	7.140.500.000
		10 – 14 mm (.39 – .55").....	7.140.600.000
		Contacts and inserts page 72 • Assembly instructions page 164	

Assembly tool 7.010.900.127 is required

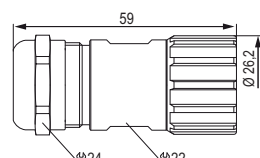
Straight Connector, Female Thread, EMC		Cable-Ø	Part Number
		3 – 7 mm (.12 – .28").....	7.141.300.000
		5 – 10 mm (.20 – .39").....	7.141.400.000
		7 – 12 mm (.24 – .47").....	7.141.500.000
		10 – 14 mm (.39 – .55").....	7.141.600.000
		Contacts and inserts page 72 • Assembly instructions page 164	

Assembly tool 7.010.900.127 is required

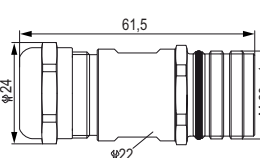
Straight Connector, Male Thread		Cable-Ø	Part Number
		3 – 7 mm (.12 – .28").....	7.240.300.000
		5 – 10 mm (.20 – .39").....	7.240.400.000
		7 – 12 mm (.24 – .47").....	7.240.500.000
		10 – 14 mm (.39 – .55").....	7.240.600.000
		Contacts and inserts page 72	

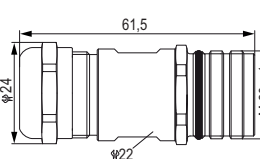
Straight Connector, Male Thread, EMC		Cable-Ø	Part Number
		3 – 7 mm (.12 – .28").....	7.241.300.000
		5 – 10 mm (.20 – .39").....	7.241.400.000
		7 – 12 mm (.24 – .47").....	7.241.500.000
		10 – 14 mm (.39 – .55").....	7.241.600.000
		Contacts and inserts page 72	

Signal Connectors / Stainless Steel (INOX)

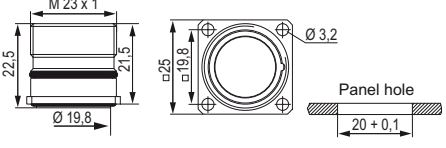
Type	Part Number	Panel Connector, Male Thread
With anti-vibration O-Ring 4 holes \varnothing 3,2 mm (.13").....7.410.400.000		
		
Contacts and inserts page 72 • Assembly instructions page 89 / 90		

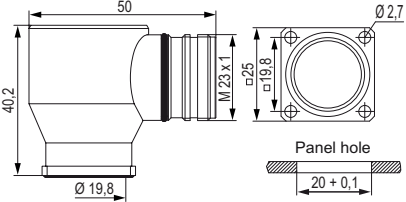
Type	Part Number	Right Angle Panel Connector, Male Thread
4 holes \varnothing 2,7 mm (.11").....7.430.400.000		
		
Contacts and Inserts page 72		

Power Connectors / Stainless Steel (INOX)

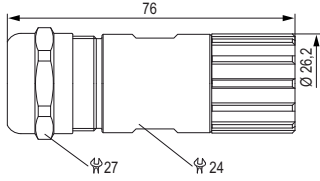
Straight Connector, Female Thread		Cable-Ø	Part Number
		7 - 12 mm (.24 - .47").....	7.554.500.000
		11 - 17 mm (.43 - .67").....	7.554.600.000
		Contacts and inserts page 112 • Assembly instructions page 120	

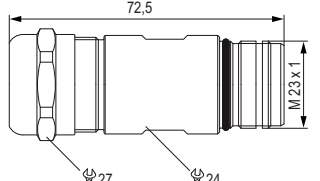
Straight Connector, Male Thread		Cable-Ø	Part Number
		7 - 12 mm (.24 - .47").....	7.564.500.000
		11 - 17 mm (.43 - .67").....	7.564.600.000
		Contacts and inserts page 112 • Assembly instructions page 120	

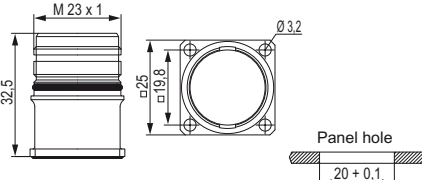
Panel Connector, Male Thread		Type	Part Number	
		For front mounting	4 holes Ø 3,2 mm (.13").....	7.601.400.000
		Optional:	Flat gasket	
		Contacts and inserts page 112 • Assembly instructions page 121		

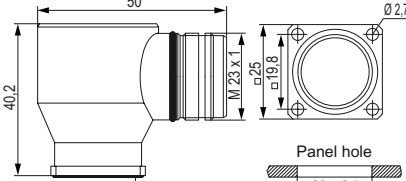
Right Angle Panel Connector, Male Thread		Type	Part Number
		4 holes Ø 2,7 mm (.11").....	7.630.400.000
		Contacts and Inserts page 112	

Stainless Steel Connectors (INOX) / Accessories

Type	Part Number	Accessories
Assembly tool	7.010.900.127	
Plastic protective cap for connectors with male thread	7.000.900.101	
for connectors with female thread	7.000.900.102	
Stainless steel protective cap for connectors with female thread	7.010.904.103	
Stainless steel protective cap with rope for connectors with female threadLength 100 mm	7.010.9S4.103	
Stainless steel protective cap for connectors with male thread	7.010.904.102	
Stainless steel protective cap with rope for connectors with male threadLength 100 mm	7.010.9S4.102	
Crimp tool for manual crimping of machined crimp contacts for signal connectors	7.000.900.901	

Operating instructions on page 114

Straight Signal Connector, Female Thread

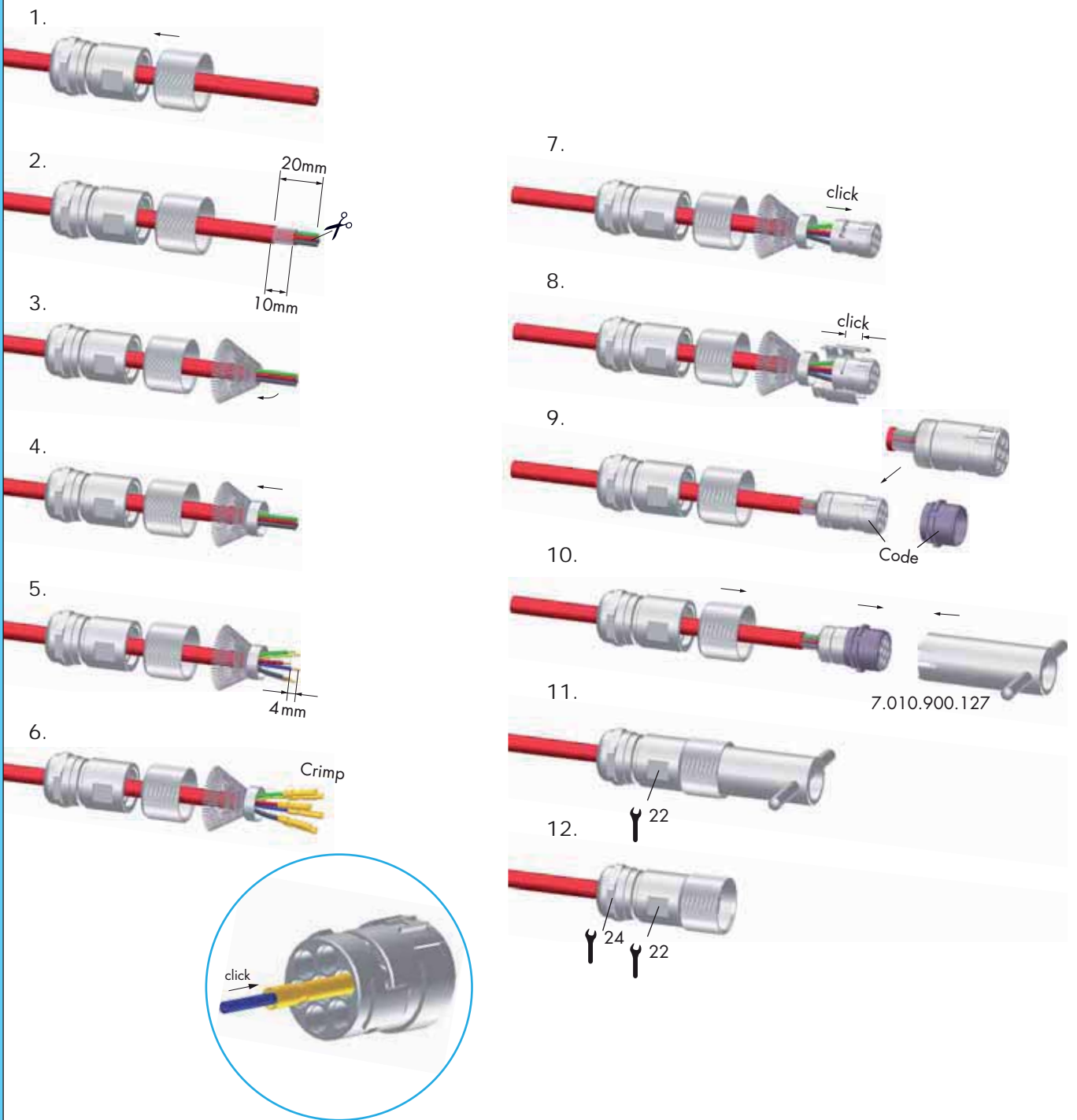

Moulded Connector Cordsets M 23



Housings

page 168



Inserts

page 72 and page 112 respectively

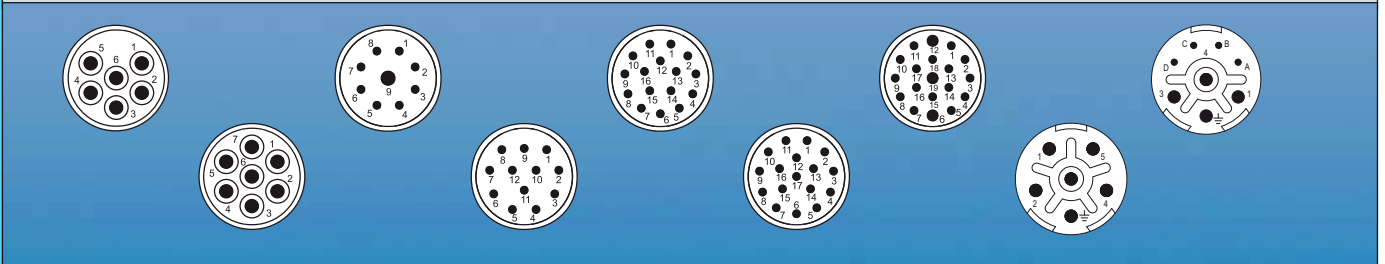

Accessories

page 80 and page 114 respectively



Moulded Connector Cordsets

Mechanical Data	Materials and Technical Data
Housing	Copper-Zinc alloy Die Casting
Moulded strain relief	Polyurethan PUR
Housing surface	Nickel plated brass, black strain relief
Inserts (for contacts)	Thermoplastic Polyamid PA 6 (Nylon 6/6), PBT Fire protection class V-0
Contacts	Brass Alloy
Contact surface at point of contact	Nickel and gold plated (0,25 µm Au)
Minimum mating cycles	> 1000
Seals / O-Rings	Buna-N standard optional Viton® (Viton is a registered trademark of DuPont)
Temperature range	-40° C – 125° C (-40 °F – 257 °F)
Type of contacts	Crimp
Protection	IP 67 / IP 69 K per EN 60 529 (connected), NEMA 4x
Cable diameter range	5 – 15 mm (.20" – .60")
Cable style	Cable specifications available upon request
Labelling	HUMMEL logo as standard, other options available upon request

Additional Information

Electrical data see standard program

Signal Connectors M23 page 63
Power Connectors M23 page 105

Inserts and contacts see standard program

Signal Connectors M23 page 72
Power Connectors M23 page 112



We do not recommend disconnecting or connecting HUMMEL Connectors under load.

Other versions



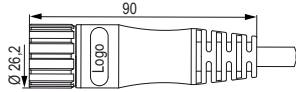

Moulded connector cordsets are also available as Push-Pull- or Stainless-Steel (Inox)-Versions.

Moulded Connector Cordsets M 23

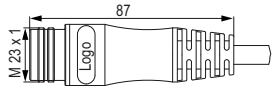

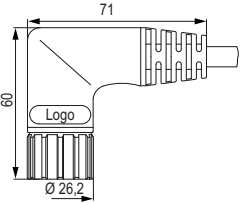
Straight Connector, Female Thread		Type	Inserts
		Standard / EMC	Pins or sockets

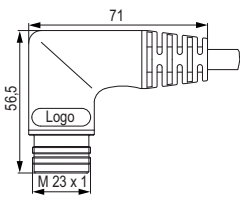

Straight Connector, Male Thread		Type	Inserts
		Standard / EMC	Pins or sockets

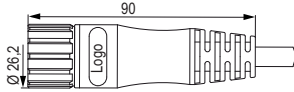

Right Angle Connector, Female Thread		Type	Inserts
		Standard / EMC	Pins or sockets

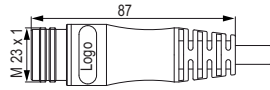

Right Angle Connector, Male Thread		Type	Inserts
		Standard / EMC	Pins or sockets

Moulded Connector Cordsets M 23

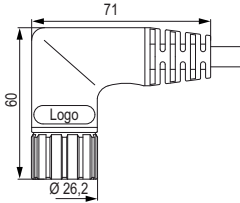
Type	Inserts	Straight Connector, Female Thread	
Standard / EMC	Pins or sockets		

Type	Inserts	Straight Connector, Male Thread	
Standard / EMC	Pins or sockets		

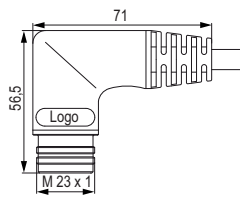
Type	Inserts	Right Angle Connector, Female Thread	
Standard / EMC	Pins or sockets		

Type	Inserts	Right Angle Connector, Male Thread	
Standard / EMC	Pins or sockets		

IP 67 – liquid tight when disconnected



Using a rubber diaphragm makes this connector liquid tight either connected or disconnected (NEMA 4 = IP 67).

Bulkhead Connector



Bulkhead connectors accept plugs on both sides. They are rugged, liquid tight and available in all number of poles.

Simple EMI / RFI shielding

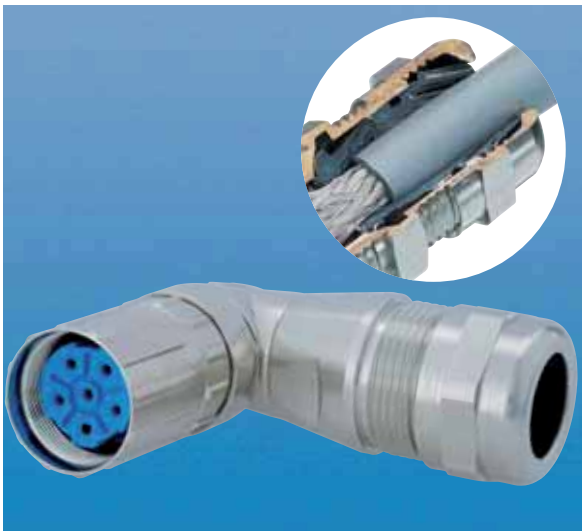

An integrated metalized EMI clamping insert grounds to the braid significantly simplifying the assembly of the elbow connector.

MULTI Seal Connector



A large selection of standard MULTI seal inserts allow strain relief of several individual conductors on one single connector.

Flexible Cable Protection



In addition to the integrated strain relief, the flex nut adds kink protection to a cable - available for all connector sizes.

Adaptor flange



To secure loose connections, an adaptor flange can be attached to a straight connector.

12-point hex and knurled nut



This special nut makes connection simple by either tightening the connector manually (knurled nut) or with a wrench (12-point hex).

Conduit Attachment



Flexible corrugated conduit can be attached to a connector with an adapter offering strain relief and cable protection as well.

Connector with specific pull-out resistance



After reaching a certain pull-out force the connection releases preventing damage to the device (apparatus).

Bulkhead Fitting



This fitting with oversized flange is commonly used in the ship building industry where Signal Connections have to be maintained under extreme conditions.

Captive Protective Cap



The metal protective cap is secured to a cable by a safety ring and stays attached in open connections.

ANACONDA Conduit Adapter



HUMMEL offers custom adapters for ANACONDA conduit systems in hazardous locations.

Page Finder

Part Number	Page	Part Number	Page	Part Number	Page	Part Number	Page
7.000.900.101	136	7.010.900.163	28	7.140	160	7.589	107
49/57/80/114/163		7.010.900.167	99	7.141	160	7.601	107
7.000.900.102	136	7.010.900.168	99	7.156	151	7.601.4	162
49/57/80/114/163		7.010.900.169	99	7.206	64	7.605	107
7.000.900.151	136	7.010.900.170	99	7.208	42	7.621	108
7.000.900.152	136	7.010.900.183	49	7.210	96	7.623	108
7.000.900.901	99/115/163	7.010.900.200	29	7.240	160	7.626	108
7.000.900.902	137	7.010.900.201	29	7.241	160	7.630.4	162
7.000.900.903	137	7.010.900.202	29	7.300	65	7.635	110
7.000.900.904	29/81	7.010.900.203	29	7.301	65	7.636	110
7.000.900.906	50	7.010.900.204	29	7.304	151	7.637	110
7.000.900.907	50	49/58/81/115		7.305	151	7.638	110
7.000.980.16	28	7.010.900.205	29	7.306	65	7.638.1	110
7.000.980.167	99	49/58/81/115		7.308	42	7.641	107
7.000.980.168	99	7.010.900.206	66	7.350	65	7.645	107
7.000.9DM.C03	81	49/58/81/115		7.400	66	7.651	108
7.000.9DM.C04	81	7.010.900.207	66	7.402	66	7.653	111
7.000.9DM.C06	115	49/58/81/115		7.404	66	7.661	111
7.000.9DM.C07	115	7.010.900.208	66	7.406	66	7.681	111
7.001.903	22	49/58/81/115		7.408	42	7.683	111
7.001.906	72	7.010.900.209	66	7.410.0	66	7.710	130
7.001.907	72	49/58/81/115		7.410.4	161	7.715	154
7.001.910	23	7.010.900.214	137	7.410.7	96	7.720	130
7.001.912	74	7.010.900.215	137	7.412	66	7.725	155
7.001.916	75	7.010.900.216	137	7.414	66	7.740.0	131
7.001.917	75	7.010.900.217	137	7.416	66	7.740.5	156
7.001.919	76	7.010.900.129	137	7.420	67	7.742	132
7.001.920	44	7.010.901.001	26/78	7.421	67	7.743	132
7.001.926	97	7.010.901.002	26/44/78	7.422	67	7.744	131
7.001.928	97	7.010.901.012	26/44/78	7.423	67	7.810	18
7.001.943	23	7.010.901.021	78	7.425	67	7.813	150
7.001.981	73	7.010.901.022	44/78	7.430.4	161	7.820	18
7.001.983	22	7.010.901.031	78	7.431	68	7.823	150
7.001.985	24	7.010.901.5	78	7.432	68	7.830	19
7.001.988	24	7.010.902.0	79	7.433	68	7.831	19
7.002.912	74	7.010.904.102	163	7.433.1	68	7.840	20
7.002.917	76	7.010.904.103	163	7.435	68	7.840.3	150
7.002.981	73	7.010.94	113	7.440.0	66	7.842	20
7.003.903	22	7.010.950.102	152	7.440.5	152	7.843	20
7.003.906	72	7.010.95S.102	152	7.444	66	7.845	21
7.003.907	72	7.010.971	98	7.448.0	66	7.847	19
7.003.910	23	7.010.980.6	44	7.448.5	152	7.850.0	21
7.003.912	74	7.010.980.8	26	7.449	66	7.850.3	150
7.003.916	75	7.010.981	26	7.450	69	7.852	19
7.003.917	75	7.010.982	27	7.452	69	7.810.4	54
7.003.919	76	7.010.950.702	27	7.454	69	7.820.4	54
7.003.920	44	49/57/80/114		7.456	69	7.840.0	54
7.003.926	97	7.010.950.703	57/80/114	7.458	69	7.841.0	54
7.003.943	23	7.010.950.704	28	7.459	69	7.842.0	55
7.003.981	73	7.010.950.705	28	7.460	69	7.850.0	55
7.003.983	22	7.010.950.707	99	7.462	69	7.843.0	55
7.003.985	24	7.010.950.708	99	7.464	69	7.845.0	55
7.003.988	24	7.010.950.783	49	7.466	69	7.852.4	56
7.004.912	74	7.010.9S1.002	43	7.468	43	7.847.4	56
7.004.917	76	49/57/80/114		7.476	64	7.101	71
7.004.981	73	7.010.9S1.003	57/80/114	7.486	64	7.102	71
7.010.900.101	80	7.010.9S1.083	49	7.490	70		
7.010.900.102	80	7.010.9S4.103	163	7.491	70		
49/57/80/114		7.010.9S4.102	163	7.492	70		
7.010.900.103	80	7.015.95	134	7.550	106		
49/57/80/114		7.015.900.102	136	7.554	162		
7.010.900.110	99	7.015.900.103	136	7.555	153		
7.010.900.125	28	7.015.9S1.002	136	7.559	106		
7.010.900.127	165	7.015.9S1.003	136	7.560	106		
7.010.900.128	58/81/115	7.084.943	112	7.564	162		
7.010.900.129	137	7.084.951	112	7.569	106		
7.010.900.135	29/49	7.106	64	7.575	153		
7.010.900.139	50	7.108	42	7.576	107		
701.090.014	50	7.110	96	7.579	107		
7.010.900.162	28	7.105	71	7.580	107		

Limited Liability

Products, design, colors and dimensions are subject to change without prior notice. We reserve the right to make technical improvements on all our products, currently ordered or for future orders. It is the users responsibility to verify all dimensions and technical data. HUMMEL AG will assume no liability regarding information provided to the user by published literature or inside technical staff, its distributors and outside sales personnel. Errors in the catalog can occur and shall not create any liability whatsoever for HUMMEL. All information provided by HUMMEL is without guarantee and must be verified by the user.

Created and printed by

Graphic & Layout: intermedia marketing gmbh, Mozartstraße 2, 79183 Waldkirch, Germany, Tel. +49(0) 76 81/ 47 78 99-0, Fax +49(0) 76 81/ 47 78 99-27, info@intermedia-marketing.de
 Printer: Druckerei Furtwängler GmbH, 79211 Denzlingen, Germany, Tel. +49(0) 76 66/13 31. Printed on recycled paper in March 2009. English 2009

HUMMEL Brazil

HUMMEL Connector Systems Ltda.
 Av. Derville Gabriel Pereira, 280
 Barro Preto Centro Empresarial Tatuí I
 CEP 18280-623 - Tatuí / SP / Brazil
 Tel. +55 (15) 33 22-70 00
 Fax +55 (15) 33 22-70 26
 E-Mail vendas@hummel.com.br

www.hummel.com



HUMMEL Bulgaria

HUMMEL Sales Office Bulgaria
 Bul. "Cherni vrah" 43
 1407 Sofia / Bulgaria
 Tel: +359 (2) 9 62 06 31
 Fax: +359 (2) 9 62 06 31
 E-Mail: p.brankov@hummel.com

www.hummel.com



HUMMEL China

HUMMEL Connector Systems (Shanghai) Co., Ltd.
 Central Plaza 1111
 Huang Pi Bei Road 227
 200003 Shanghai / P.R. China
 Tel. +86 / 21 63 75 85-51
 Fax +86 / 21 63 75 85-53
 E-Mail info.hcs.cn@hummel.com

www.hummel.com



HUMMEL Great Britain

HUMMEL UK Limited
 Stedman House
 95 Church Street, Leigh, Lancashire, WN71 AZ
 United Kingdom
 Tel. +44 (0) 19 42 / 60 56 95
 Fax +44 (0) 19 42 / 26 93 24
 E-Mail s.kelly@hummel.com

www.hummel.com



HUMMEL India

HUMMEL Connector Systems Pvt. Ltd.
 162-A / 9 Kishan Garh, Main Road, Vasant Kunj
 New Dehli - 110070 / India
 Tel: +91 11 26 89 40 05
 Fax: +91 11 26 89 40 06
 E-Mail: info.in@hummel.com

www.hummel.com

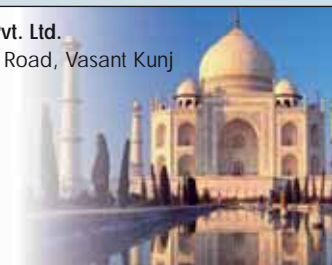

HUMMEL Italy

HUMMEL s.r.l.
 Via Valdellatorre 182
 10091 Alpignano (Torino)
 Italy
 Tel. +39 / 0 11 / 9 68 26 38
 Fax +39 / 0 11 / 9 78 55 50
 E-Mail info.hcs.it@hummel.com

www.hummel.com



HUMMEL Poland

HUMMEL sales Office Poland
 Al. 23 Stycznia 26 lok. 30
 86-300 Grudziadz / Poland
 Tel: +48 (0) 6 62 38 27 99
 Fax: +48 (0) 5 66 43 00 11
 E-Mail: g.piotrowski@hummel.com

www.hummel.com



HUMMEL Russia

OOO HUMMEL Russische Föderation
 105082, Moskau
 ul. B. Potschtovaja, d.34, str.8, of.213
 Tel. +7 / 495 / 7 37 - 44 97
 Fax +7 / 495 / 7 37 - 44 98
 E-Mail info@hummel-russia.ru

www.hummel.com



HUMMEL Scandinavia

HUMMEL Management Special Projects
 Första Magasinsgatan 5
 80310 Gävle / Sweden
 Tel. +46 (73) 8 00 12 00
 Fax +46 (26 14) 38 73
 E-Mail t.larsson@hummel.com

www.hummel.com



HUMMEL Hungary

HUMMEL Connector Systems Kft.
 Körösi út 49.
 2360 Gyál / Hungary
 Tel. +36 / 29 54 06 33
 Fax +36 / 29 54 06 35
 E-Mail info.hcs.hu@hummel.com

www.hummel.com



- Cable Glands
- Circular Connectors
- Cable Protection
- Industrial Enclosures

info.et@hummel.com



- Sensor Technology
- Controls
- PLC or Control Panel
- Temperature Regulator
- Charging

info.el@hummel.com



- Systems Solutions
- Cable Assembly
- Custom fabrication of Enclosures
- Front Plates

info.el@hummel.com



- Metal and Nylon custom parts

info.mk@hummel.com



- Valves and Fittings
- DesignTechnik

info.hs@hummel.com



HUMMEL AG

Division ET
Lise-Meitner-Straße 2
79211 Denzlingen
Germany

Tel. +49 (0) 76 66 / 9 11 10-0
Fax +49 (0) 76 66 / 9 11 10-20
E-Mail info.et@hummel.com

HUMMEL AG

Lise-Meitner-Straße 2
79211 Denzlingen
Germany
www.hummel.com

