

THESE DRAWINGS ARE THE PROPERTY OF QUALTEK ELECTRONICS AND NOT TO BE REPRODUCED FOR OR COMMUNICATED TO A THIRD PARTY WITHOUT THE EXPRESS WRITTEN PERMISSION OF AN OFFICER OF QUALTEK ELECTRONICS.

REVISION			
REV.	DESCRIPTION	DATE	APPROVED
B	RoHS Compliancy	06-01-06	DP

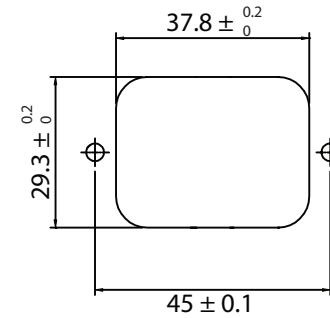
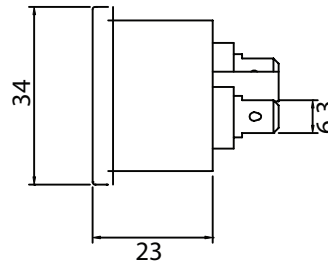
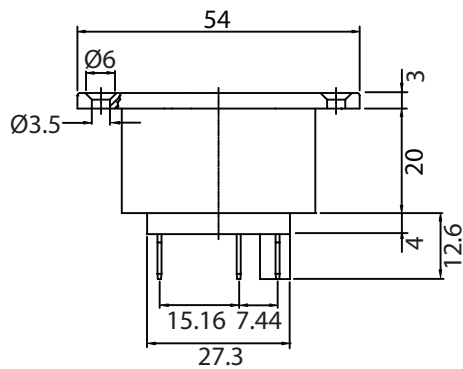
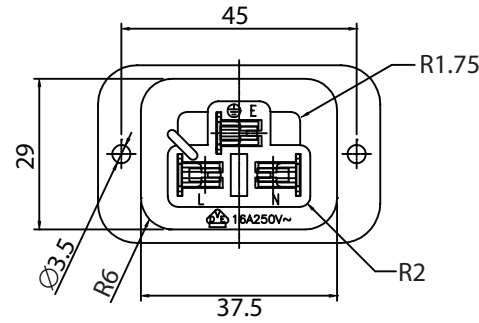
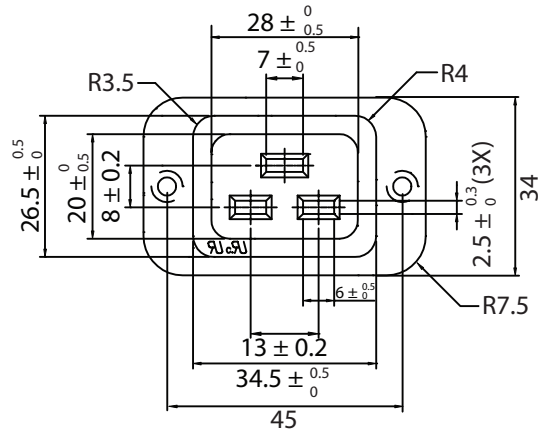

PANEL CUTOUT

NOTES:

STANDARD: IEC 60320-1
 RATING:
 UL,cUL: 20A/250V AC
 VDE: 16A/250V AC
 APPROVALS: UL,cUL, CSA, VDE
 IEC 60320 C19
 RoHS COMPLIANT

CONTROLLED

Dim range (mm)	Tolerance +/- (mm)	Qualtek Electronics Corp. PPC DIVISION		
		Part Number: 743W-00/03	RoHS Compliant	
0-1	0.15	Description: AC RECEPTACLE		
1-6	0.20			
6-18	0.30	UNIT: mm	REV. B	
18-50	0.50		Approved / Date	
50-120	0.70	Drawn / Date	Checked / Date	Approved / Date
120-250	0.90	B.Zhang 10-27-03	10-27-03	JJH / 10-27-03
250-500	1.20			