

Electronics End Cutting Nippers

DIN ISO 9654



64 01 115

head polished, handles plastic coated

Style 0:End Cutter, with bevel



64 02 115

head mirror polished, handles with multi-component grips

Style 0:End Cutter, with bevel



64 11 115

head polished, handles plastic coated

Style 1:End Cutter, with small bevel



64 12 115

head mirror polished, handles with multi-component grips

Style 1:End Cutter, with small bevel



64 22 115

head mirror polished, handles with multi-component grips, mini-blade

Style 2:End Cutter, mini-blade with small bevel



64 32 120

head mirror polished, handles with multi-component grips, Oblique End Cutter
Style 3:Oblique End Cutter, short head, with small bevel, $\alpha = 15^\circ$



64 42 115

head mirror polished, handles with multi-component grips, Oblique End Cutter, short head
Style 4:Oblique End Cutter, short head, with small bevel, $\alpha = 27^\circ$



64 52 115

head mirror polished, handles with multi-component grips, Oblique End Cutter, short head
Style 5:Oblique End Cutter, short head, without bevel, for flush cutting, $\alpha = 27^\circ$



64 62 120

head mirror polished, handles with multi-component grips, Oblique End Cutter, mini-blade
Style 6:Oblique End Cutter, mini-blade with small bevel, $\alpha = 65^\circ$



64 72 120

head mirror polished, handles with multi-component grips, Oblique End Cutter, mini-blade, head with recess
Style 7:Oblique End Cutter, mini-blade with small bevel, head with recess, $\alpha = 35^\circ$



- Description
- Technical design
- precision pliers for ultra fine cutting work, e. g. in electronics and fine mechanics

- precision boxjoint
- low-friction double spring for gentle and even opening
- the polish or mirror polish (only finish 2) together with a fine film of oil offer the best possible rust protection - no circuit faults caused by peeling chrome from plated tools
- cutting edge hardness at least 56 HRC
- High-grade special tool steel, forged, oil-hardened

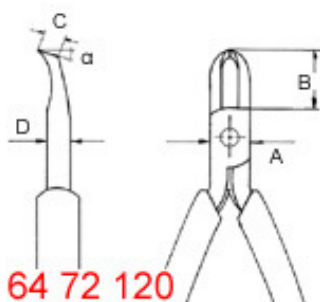
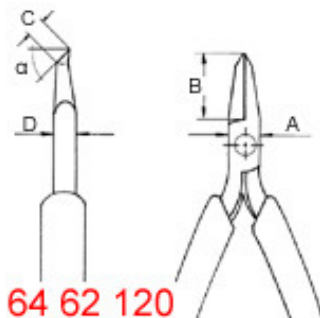
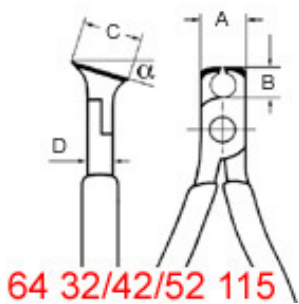
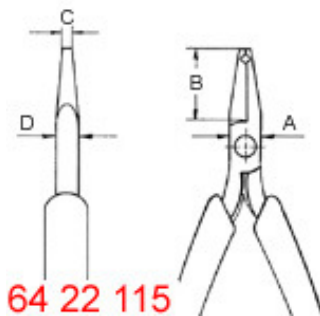
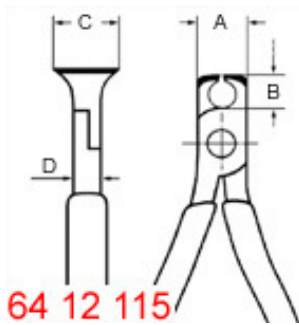

No.	EAN 4003773-	Ø mm	Ø mm	Ø mm	A mm	B mm	D mm	C mm	mm	 g
64 01 115	017745	2.00	1.00	0.60	11.00	6.00	7.50	16.00	115	76
64 02 115	035343	2.00	1.00	0.60	11.00	6.00	7.50	16.00	115	94

64 11 115	017769	1.40	0.80		11.00	6.00	7.00	16.00	115	74
64 12 115	040743	2.00	0.80	0.50	11.00	6.00	7.00	16.00	115	91
64 22 115	017806	0.80			10.00	20.00	6.00	3.00	115	65
64 32 120	017820	1.50	1.00	0.50	11.00	10.00	7.00	17.00	120	92
64 42 115	017844	1.50	1.00	0.50	10.50	10.00	7.00	12.00	115	69
64 52 115	040439	1.30			10.50	10.00	7.00	12.00	115	69
64 62 120	046998	0.60			9.50	18.50	6.00	5.00	120	70
64 72 120	017882	1.50			12.00	19.50	7.00	5.00	120	95

technical change and errors excepted