

THIS DRAWING IS UNPUBLISHED. RELEASED FOR PUBLICATION  
 © COPYRIGHT BY TYCO ELECTRONICS CORPORATION. ALL INTERNATIONAL RIGHTS RESERVED.

LOC	DIST	REVISIONS			
P	LTR	DESCRIPTION	DATE	DWN	APVD
	M2	REVISED PER ECR-09-009910	4/27/09	SS	PD

1 CONTINUOUS STRIP ON REELS  
 2 PRELIMINARY - NOT FOR PRODUCTION

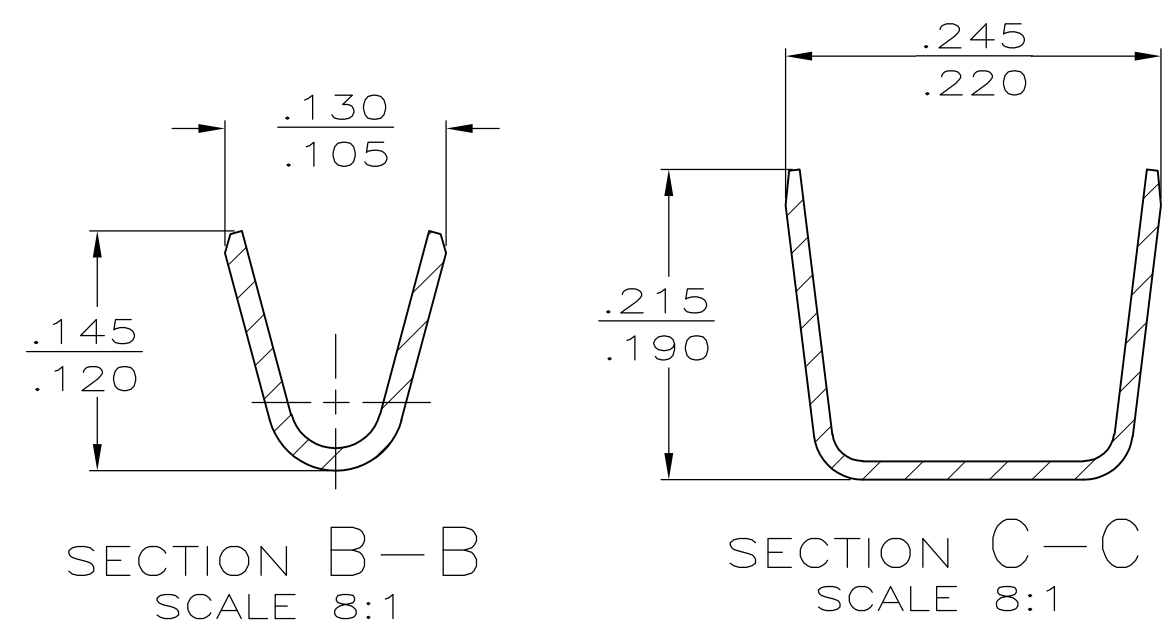
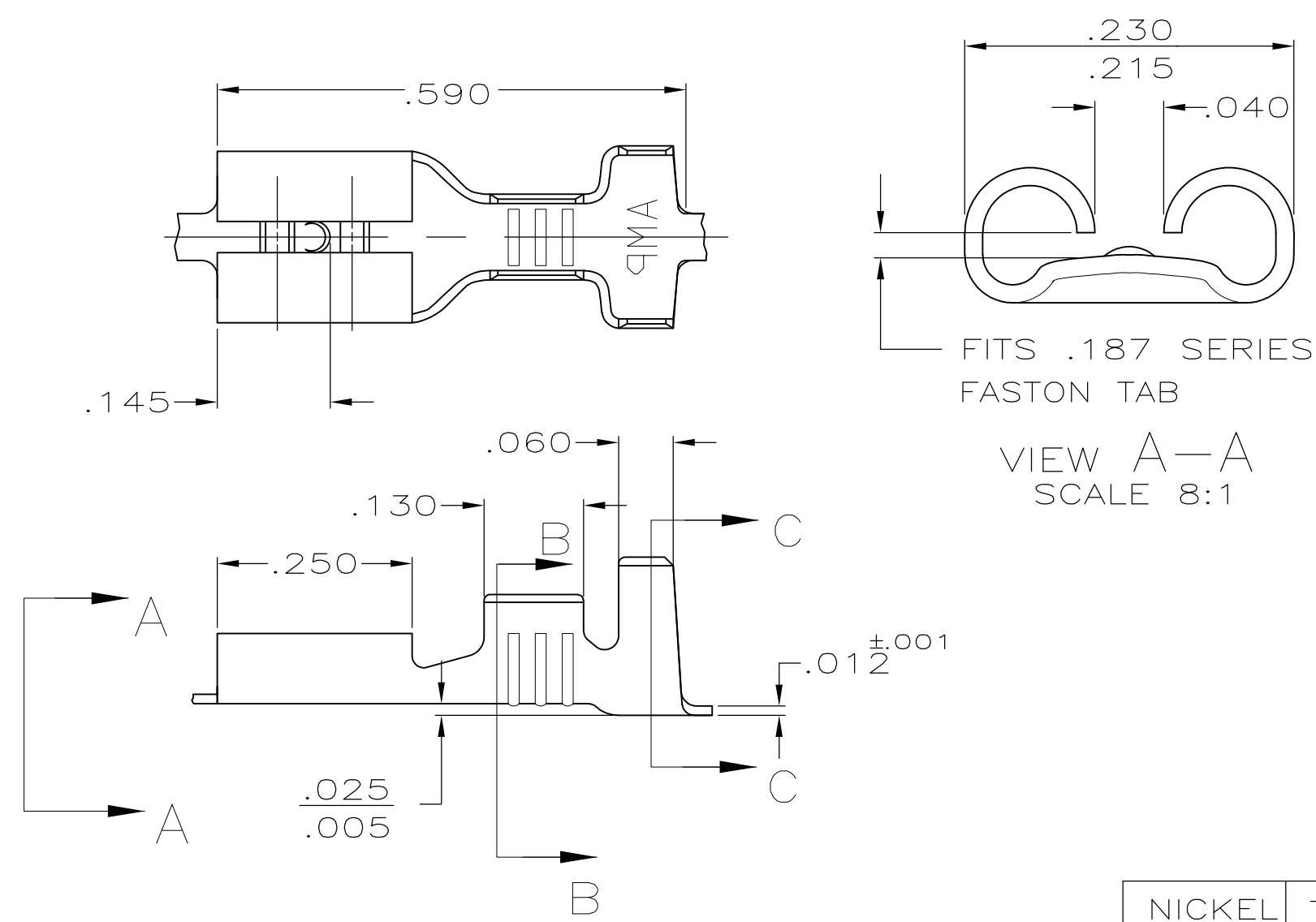

NICKEL	T2 STEEL		18-16		2 60487-3
TIN	#4H BRASS	.105-.210 OR (2) .105 MAX	OR (2) #18's	.020	60487-2
-					60487-1
FINISH	MATERIAL	INSULATION RANGE	WIRE SIZE	MATING TAB THK ±.001	PART NO

F	.210	.188	F	.100	.055	16
					.049	18
TYPE	WIDTH	STRIP LENGTH ±.015	TYPE	WIDTH	±.002 HEIGHT	WIRE
INSUL BARREL CRIMP			WIRE BARREL CRIMP			

THIS DRAWING IS A CONTROLLED DOCUMENT.

DWN	JR RUTH	7/14/89	Tyco Electronics Corporation Harrisburg, PA 17105-3608
CHK	MS FEHER	7/14/89	
APVD	-	-	NAME
PRODUCT SPEC	-	-	RECEPTACLE, FASTON, .187 SERIES
APPLICATION SPEC	-	-	
WEIGHT	-	-	SIZE
			CAGE CODE
			DRAWING NO
			RESTRICTED TO
			A300779
			G-60487
			SCALE
			5:1
			SHEET
			1 OF 1
			REV
			M2

CUSTOMER DRAWING