

Product Data Sheet

603 JJ XX Cres

Replace "XX" with 01 through 12 for number of poles

Terminal Block– Open Back

50 Amps, 600 Volts (AC/DC)



(5 Pole shown)

Insulator Strip Required for Voltage Rating

Copper Wire Only

Wire Range with Wire Binding Screw: #10 - #16 AWG

Wire Range with Listed Ring or Fork Lug: #6 – 16 AWG

11/16" Centers

Application torque: 20 in. lbs

Electrical Ratings:

- 50A (Based on NEC standards of 75°C ampacity)
- Wires larger than #10 AWG require listed ring or fork lug
- 600 Volts AC/DC (UL 1059 Class B and C, User Group – Commercial Appliance and General Industrial)
- Short Circuit Current Rating: 10,000A (Default)
- Approved for Factory and Field Wiring.

Mechanical Ratings:

- Storage and transportation temperature range: -35°C to 110°C (-31°F to 230°F)*
- Maximum insulator base temperature: 130°C (266°F)* UL RTI
- Flammability rating of insulator base: UL 94V-0

* Use outside these ratings needs to be judged in the end-use application.

Materials:

- Connector: Brass, tin plated.
- Insulator base: JJ (GDI-30F). Glass-fiber filled, diallyl ortho-phthalate.
- Screw, #10-32 Machine Screw: Stainless steel
- Rivet: Brass, tin plated.

Agency Approvals:

- UL Recognized, UL 1059 Terminal Block Standard, File No. XCFR2.E47811
- CSA Certified, CSA C22.2 No. 158, File No. LR19766
- CE compliant, IEC 60947-7-1

- RoHS Compliant
- Material certifiable to Military Specifications MIL-M-14 and MIL-P-19833.

Suggested product mounting hardware: #8 fastener, torque to 15 in. lbs.

ACCESSORIES:

- Printing (for printing options, see Terminal Block Printing on website)

- Marking strips - sub mounted or top mounted. Can be made from XP (general purpose laminate), XXXPFR (flame retardant), GME (glass cloth melamine), or GEE (glass cloth epoxy) material. (For Printing Options, see section on website)



- Insulator strips - sub mounted, black only (BB) (Printing Unavailable). Insulator Strip will be the same width as the molding.

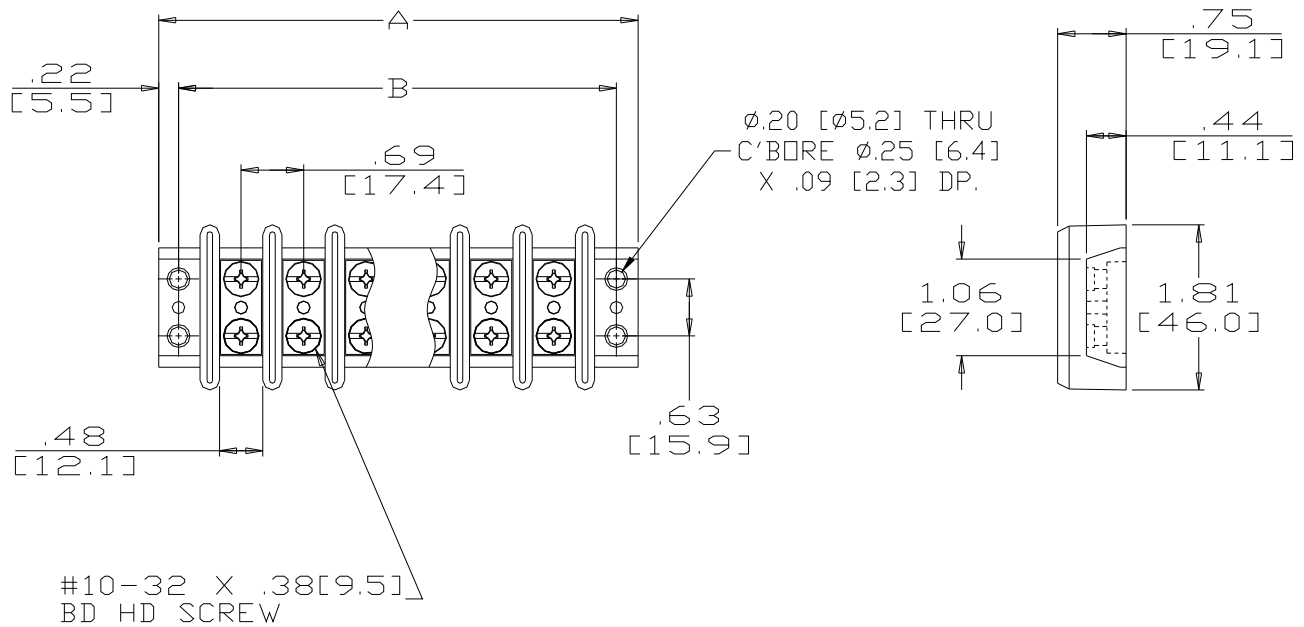

Dimensions

A B

603 JJ 01	1	1.81	1.38
603 JJ 02	2	2.50	2.06
603 JJ 03	3	3.19	2.75
603 JJ 04	4	3.88	3.44
603 JJ 05	5	4.56	4.13
603 JJ 06	6	5.25	4.81
603 JJ 07	7	5.94	5.50
603 JJ 08	8	6.62	6.19
603 JJ 09	9	7.31	6.87
603 JJ 10	10	8.00	7.56
603 JJ 11	11	8.68	8.25
603 JJ 12	12	9.37	8.94

MM = Dim X 25.4

WWW.MARATHONSP.COM

1-419-352-8441

PDS 0294 REV B 2/25/16