

THIS DRAWING IS UNPUBLISHED. RELEASED FOR PUBLICATION, 19 .
 © COPYRIGHT 19 BY AMP INCORPORATED. ALL INTERNATIONAL RIGHTS RESERVED.

LOC	DIST	P	F	ZONE	LTR	DESCRIPTION	DATE	APPD
AF	50				A	REV PER 0335-94	6/23/94	JR/JG

1 SUPPLIED IN LOOSE PIECE.

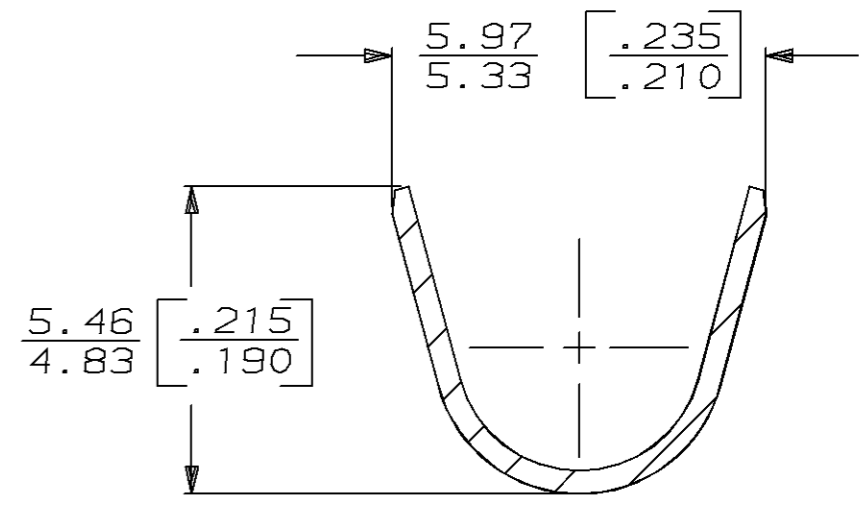
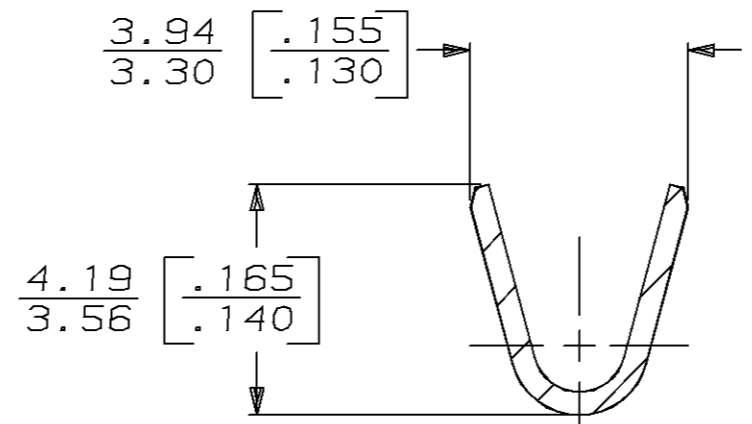
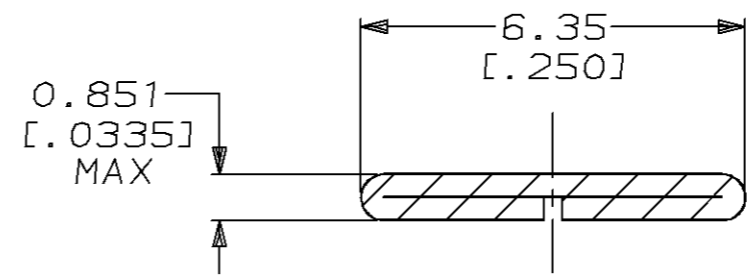
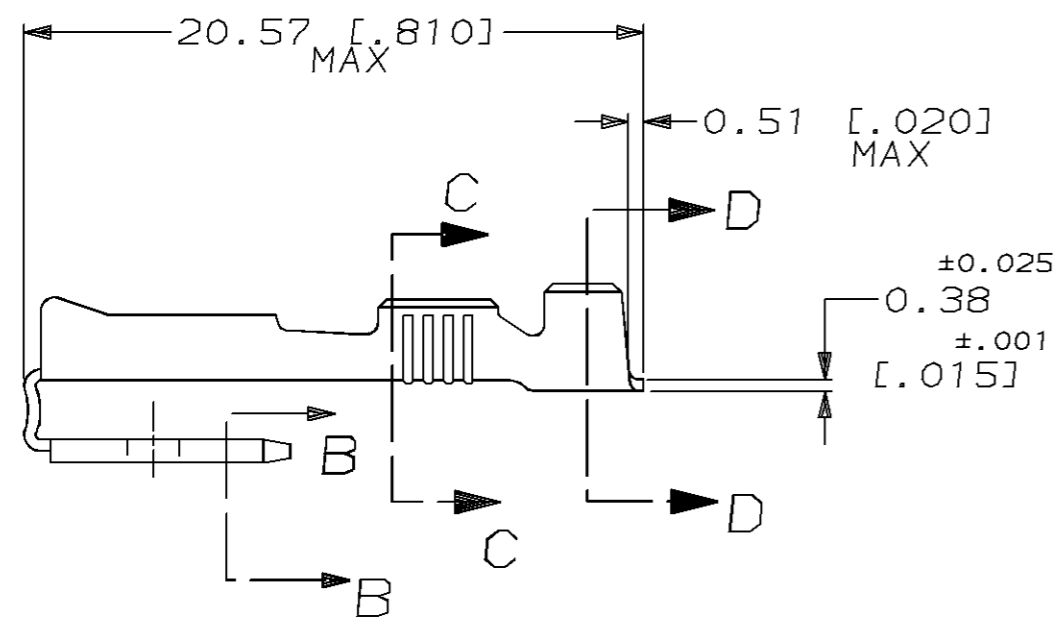

THIS DRAWING IS A CONTROLLED DOCUMENT FOR AMP INCORPORATED. IT IS SUBJECT TO CHANGE AND THE CONTROLLING ENGINEERING ORGANIZATION SHOULD BE CONTACTED FOR THE LATEST REVISION.

3.05-4.32 DIA [.120-.170] DIA	[#18-#14] AWG	TIN	60279-2
INSUL RANGE	WIRE SIZE	-	60279-1
DO NOT SCALE PRINT. UNLESS SPECIFIED DIMENSIONS IN mm [INCHES] TOLERANCES ON: 2 PLC DEC ± 0.25 [.010] 3 PLC DEC ± - ANGLES ± -	DR 11/17/93 JR RUTH CHK 11/17/93 MS FEHER APPD 11/17/93 J GILLESPIE APPD 11/17/93 R REINER PRODUCT SPEC -	FINISH	PART NO
MATERIAL #4H BRASS	FINISH SEE TABLE	AMP AMP Incorporated Harrisburg, PA 17105-3608	
		NAME RECEPTACLE, FASTON, 6.35 [.250] SERIES	
		SIZE B	CAGE CODE 00779
		SCALE 4:1	DRAWING NO C-60279
			SHEET 1 OF 1