

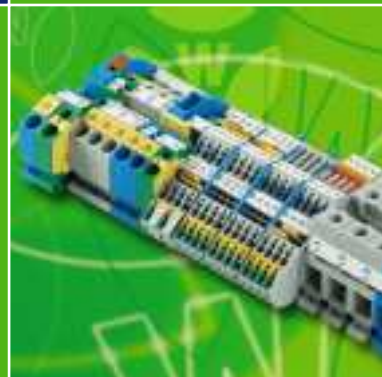

**fasis** BIT / **fasis** BIT-S / **selos** BIT

**DIN Rail Terminal Blocks  
for Junction Boxes**

**Variety as a Matter of Principle**





▲ Sales and Marketing Center in Bamberg



▲ Company headquarters in Bamberg



▲ STOCKO main plant in Wuppertal

# wieland group

## ACTIVE WORLDWIDE

The Wieland Group employs more than 2,000 people all around the globe. With some 15 locations and subsidiaries, and sales partners in more than 70 countries, the Wieland Holding is present in nearly all important key markets worldwide.

Always with a clear commitment to the German location where most of the products are still manufactured.



*automation*

*building*

*electronics*

## The group makes us strong

The Wieland Holding is based in Bamberg, Bavaria, and comprises two independently acting subsidiaries: Wieland Electric and STOCKO Contact.

Groundbreaking innovations made Wieland Electric one of the leading suppliers of electrical connection technology. This company, founded in Bamberg in 1910, is the largest subsidiary of the Wieland Holding.

STOCKO Contact is based in Wuppertal and joined the Wieland Group in 2001. Stocko has also more than 100 years of company history to its credit and is one of the greatest manufacturers of connector systems and crimp contacts.



**Established in industries**

Control cabinet engineering, industrial automation, building system technology – our large product portfolio provides solutions for all kinds of applications.

From innovative interface and network technology to terminal blocks to "safety first" – with modular system solutions and safety components. With Wieland products in your control cabinet, you are always on the safe side.

Energy bus systems for distributed automation or indoor and outdoor field

bus components – Wieland technology can be found everywhere, and in all kinds of applications.

In building system technology, Wieland Electric is the world market leader in pluggable electrical installation.

There are good reasons why our system solutions can be found in the most spectacular building projects worldwide. When it comes to electronic networking, Wieland leads the way to the "intelligent house".

**Welcome Future**

Wieland Electric is 100 years young, and full of innovative energy. And our commitment for the future is not only to find constantly new system solutions for our customers but also social responsibility.

Environmentally friendly high-tech products, manufactured to the latest production standards, an audited environmental management system and substantial investments in our locations are all part to this concept.

Global commitment and sustainable regional action – Wieland Electric is fit for the future: Contacts are green.



## DIN rail terminal blocks for junction boxes

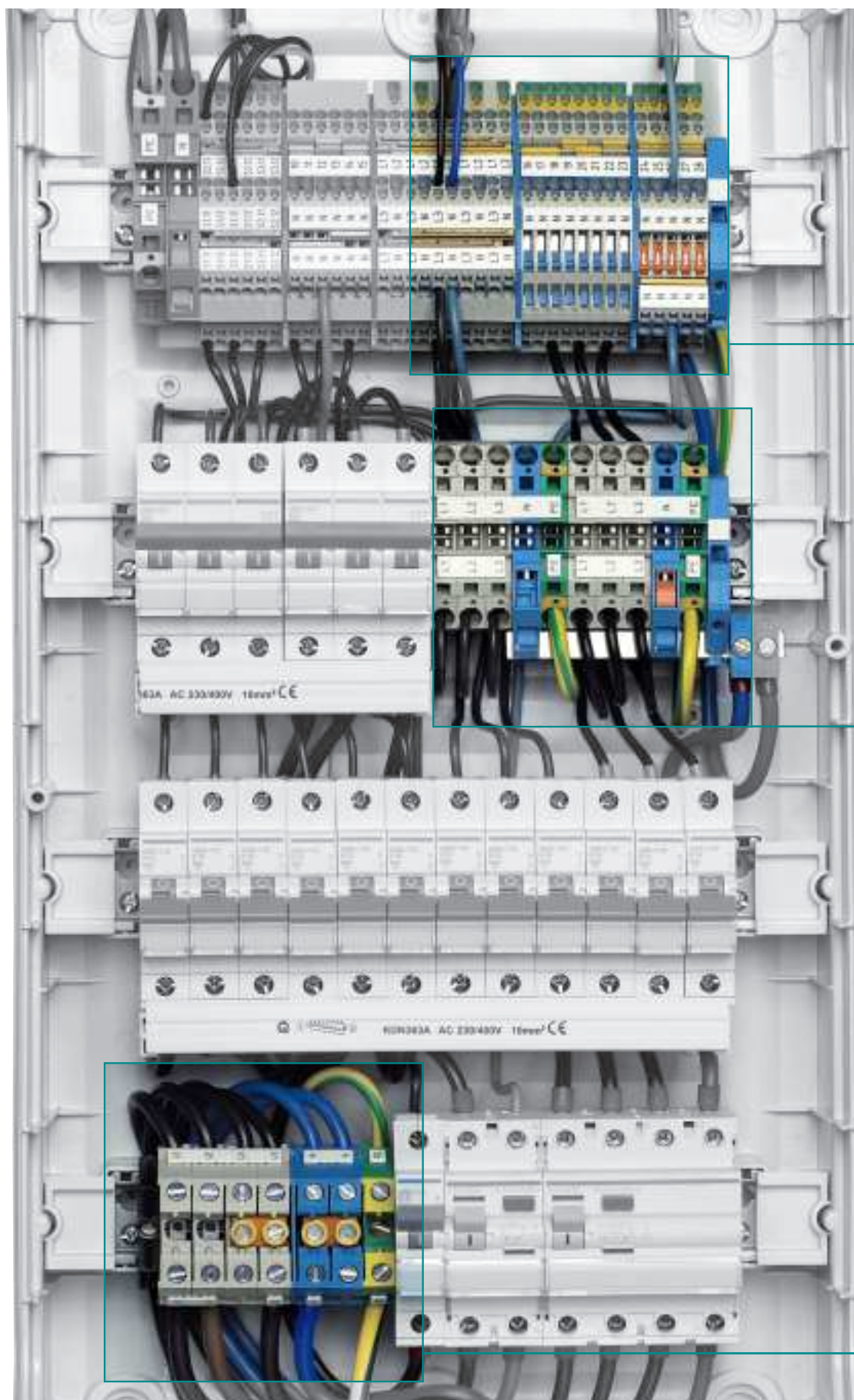

**“We at Wieland”** know what you need!

For more than 100 years we have been your competent partner in the field of connection technology for your products. Close cooperation with our customers helps to create innovative products manufactured according to the highest quality standards.

Increasing automation as well as the safety functions to be implemented inside buildings increase the requirements for power and signal management in electrical distribution systems. The growing number of circuits and the increasingly confined space available requires a DIN rail terminal block system that reduces the amount and costs of cabling but still enables clear and convenient wiring.

Wieland’s DIN rail terminal blocks provide you with the right solution.

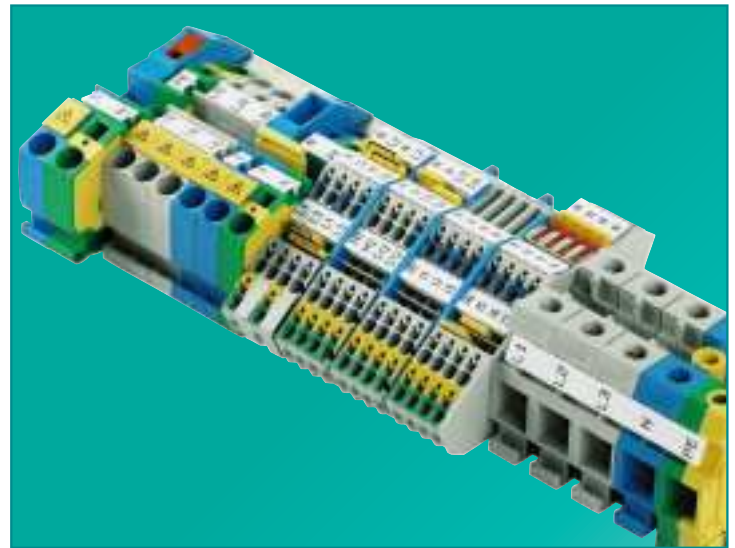

**selos/fasis**  
BIT

**fasis** BIT-S  
Type WKIS...

**selos** BIT  
Type WK/WKI...

**selos** BIT  
Type WK/WKI...

**The right solution for your application**

All DIN rail terminal blocks in the BIT series comply with the directives for the setup of high-voltage and supply systems for safety services according to VDE 0108 and have been designed for use in public buildings. Isolation measurement, for example, can be carried out with the wires connected.

You have the choice. The connection technology can be implemented either in purely spring clamp or screw technology or they can be mixed together.

**DIN rail terminal blocks with push-in spring**

The new installation blocks of series **fasis** BIT-S with push-in spring are an outstanding extension of the existing range.

**fasis** BIT-S helps to increase efficiency in electrical installations even more since rigid as well as flexible wires with ferrules can be directly connected without opening the termination point thus achieving considerable time savings.

**DIN rail terminal blocks with tension spring**

The tension spring technology of series **fasis** BIT stands out due to its maintenance-free and vibration-proof connection technology. The TOP connection is especially suitable for confined spaces.



































Due to its great product variety and a wire range between 0.5 mm<sup>2</sup> and 16 mm<sup>2</sup> the **fasis** BIT series enables many innovative solutions for various requirements.

**DIN rail terminal blocks with screw connection**

The screw connection technology of series **selos** BIT is the best known and most used connection technology worldwide. The lateral connection option makes wiring more convenient in installations, especially on the supply side and in the case of larger cross sections.

The **selos** BIT series can be used universally; with its wire range between 0.5 mm<sup>2</sup> and 50 mm<sup>2</sup> it is very user-friendly.

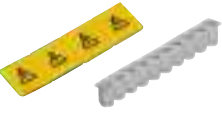
**DIN rail terminal blocks for junction boxes  
with tension spring connection, type *WKF/WKIF/WKIS***

<b>Page 14/15</b>	 WKF 2,5/35	 WKF 2,5 D1/2/35	 WKF 4 /35		 WKF 16/35 PV/WKF
<b>Page 16/17</b>	 WKF 6/35	 WKF 10/35	 WKIF 16/1 /35	 WKF 16/35	
<b>Page 18/19</b>	 WKF 4 NT/35	 WKF 10 NT/35	 WKIF 16/1 NT/35		 WAK 16/2, WAK 35/2
<b>Page 20/21</b>	 WKF 2,5 SL/35	 WKF 2,5 D1/2/SL/35	 WKF 4 SL/35		
<b>Page 22/23</b>	 WKF 6 SL/35	 WKF 10 SL/35	 WKIF 16/1 SL/35	 WKF 16 SL/35	
<b>Page 24/25</b>	 WKIF 2,5 D	 WKIF 2,5 D-D WKIF 2,5 N-D	 WKIF 2,5 D-D-SL WKIF 2,5 N-D-SL	 WKIF 2,5 NT-D-SL	 WKIF 2,5 NTM-D-SL
<b>Page 28/29</b>	 WKIS 2,5 D	 WKIS 2,5 D-D WKIS 2,5 N-D	 WKIS 2,5 D-D-SL WKIS 2,5 N-D-SL	 WKIS 2,5 NT-D-SL	 WKIS 2,5 NTM-D-SL
<b>Page 30/31</b>	 Cross connector	 Notching tool	 PS WKC/F	 Warning symbol/LEL	 Screwdriver

## DIN rail terminal blocks for junction boxes with screw connection, type *WK/WKI/WKN*

Page 36/37	 WK 2,5/U	 WK 4/U	 WKI 10/U	 WKI 16/U	 WKI 35/U
Page 38/39	 WKN 4 ETK/U	 WKI 10 ETK/U	 WKI 16 ETK/U		WAK 16/2 BLAU, WAK 35/2 BLAU, WAK 35/2
Page 40/41	 WK 2,5 SL/35	 WK 4 SL/35	 WKI 10 SL/35	 WKI 16 SL/35	 WKI 35 SL/35
Page 42/43	 WKI 10 PEN/35	 WKI 16 PEN/35	 WKI 35 PEN/35		
Page 44/45	 WKI 4 DU	 WKI 4 D-D	 WKI 4 D-D-SL	 WKI 4 N-D-SL	 WKI 4 NT-D-SL (-GL)
Page 46	 WKI 4 NTN-D-SL	 WKI 4 TKG-D-SL			
Page 48/49	 Cross connectors	 Cross connectors uninsulated+ insulated	 Jumper bars insulated	 Cover with warning symbol	 Partition plate/cover
Page 50/51	 TS 35x7,5	 TS 35x15	 TS 35x15	 End clamp for TS 35	 End clamp for TS 35
Page 52/53	 marcom	 wiemarc	 wieplot	 Marking accessories	 Engraving unit
Page 54/55	 Marking accessories	 Marking tags	 2.5mm <sup>2</sup> /5mm wide	 4mm <sup>2</sup> /6mm wide	 10mm <sup>2</sup> /10mm wide 16mm <sup>2</sup> /12mm wide 35mm <sup>2</sup> /16mm wide
Page 56/57	 Ferrules			 Wire strippers 0.08-10mm <sup>2</sup>	 Pressing tools

## Configuration software for junction boxes, DIN rail terminal blocks



**wieplan** was developed to provide you with a powerful software tool for the configuration of terminal block assemblies using Wieland DIN rail terminal blocks.

**wieplan** is available in 4 languages. It is user-friendly and its intuitive user interface guides you step by step through the entire configuration process.

wieplan supports you in your planning activities with CAE systems providing direct data exchange, e.g. with EPLAN. After completion you can optionally order your configured terminal block assembly from Wieland for complete preassembly.

Thus **wieplan** helps you to save time and money.

### Managing projects **Benefits:**

- To begin each configuration you automatically start from the basic project management menu.
- You create new projects and are reliably guided through the easy and practice-oriented program logics.
- You always have the choice of either opening an already existing project or of creating a new one.

### Configuring terminal block assemblies without errors

#### **Benefits:**

- You work with high-quality graphs viewing the terminal blocks from the top; the accessories added are visible at any time.
- You continually use the plausibility check that reminds you of the accessories required such as end plates.
- You are provided with a product catalog with search function; you can add your own order numbers, if required; and you can create libraries for self-defined products.

### Entering order data

#### **Benefits:**

- You enter your data such as invoice and delivery address in the order data screen only once and can use them for any follow-up orders.
- You may order by e-mail; in this case the terminal block assembly data are zipped automatically.

### Terminal block assembly output

#### **Benefits:**

- You print out the order, the parts list and the drawing data, and, if required, your own order numbers.
- You create a DXF file and export the current terminal block assembly to a CAD program.
- You export the marking in CSV format including all marking data for further processing in **wiemarc**, for example.
- You can use a bidirectional interface available for your CAE system EPLAN.





## Marking system for junction boxes, DIN rail terminal blocks

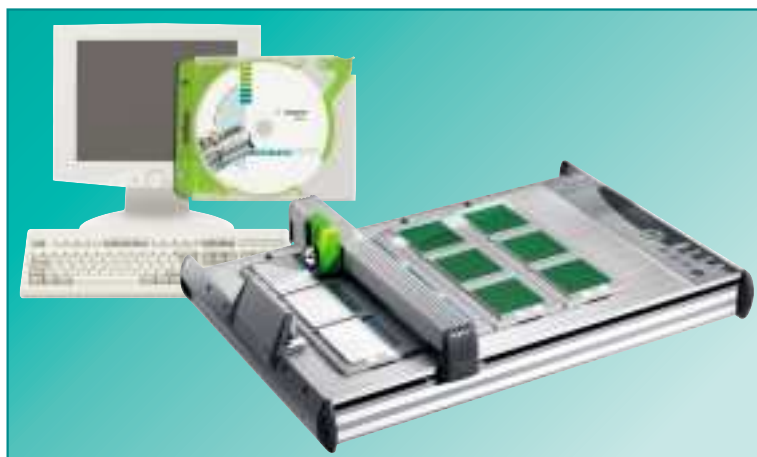

Individual marking of DIN rail terminal blocks means **wiemarc** and **wieplot** at Wieland Electric. The **wiemarc** software was developed to provide you with maximum flexibility in marking your terminal block assemblies. Together with **wieplot** you have a powerful marking system that enables you to work professionally from the individual marking tag to series marking of your terminal block assemblies. You feel confident with the system due to its easy handling and visual representation of your marking, even when you use it for the first time.

But **wieplot** offers even more!

In addition to the marking tags for DIN rail terminal blocks you can also print self-adhesive tags and labels or cable markings. A slight modification can even make your plotter a powerful engraving system.



### Marking with a system – **selos – fasis**

- Individual marking of all terminal blocks for clear wire/termination point assignment
- One single marking system for all designs
- Marking of individual tags; marking strips in the relevant terminal block spacing; or group markings
- Individual planning of terminal block assemblies and markings with **wieplan**



### Ready for universal use – **wieplot**

- Marks all common marking systems available for DIN rail terminal blocks
- Different marking tags can be marked individually in one single work step
- Marking of labels, self-adhesive tags and cables is possible



### Easy and quick – **wiemarc**

- Simple and intuitive user interface
- Direct graphical display of the marking tags including plausibility check
- Customized layouts can be created individually
- Data import from CAD, Excel, text or **wieplan** files



### Durable and safe – **wieplot** engraving system

- Easy modification to **wieplot** to make it an engraving system
- Engraving of multi-layer plastic boards
- Clean and dust-proof operation due to integrated vacuum device
- Create individual layouts using **wiemarc**

## DIN rail terminal blocks for junction boxes with tension spring connection, type *WKF/WKIF*

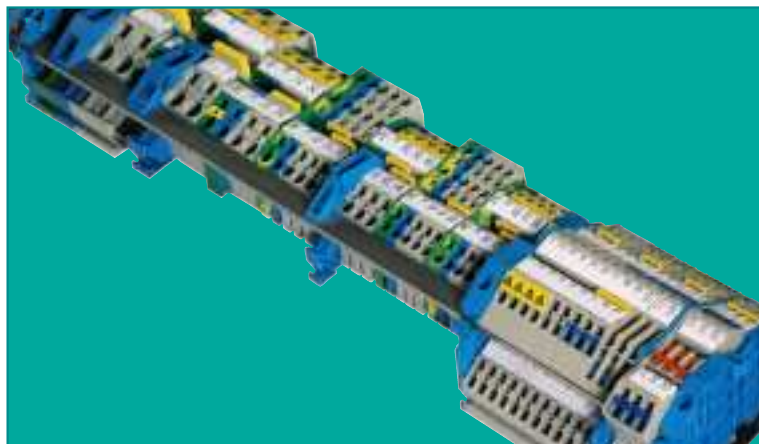

The tension spring technology of series **fasis** BIT stands out due to its maintenance-free and vibration-proof connection technology. The TOP connection is especially suitable for confined spaces. The **fasis** BIT series has been designed for use in distribution systems. It accommodates the standardized dimensions for small and field distribution units with cover according to DIN 43871.

The neutral disconnect function integrated in **fasis** BIT enables the specified isolation measurement of all active conductors without having to disconnect the neutral conductor; the system can therefore be used in public and functional buildings.



**Installation block  
WKIF 2,5...**

### **Circuit wiring with only one terminal block**

- Wiring and assignment of the circuits clearly visible due to 5 mm wide, three-tier design.
- Neutral conductor connection, line feed-through and ground connection are combined in one terminal block.
- Safety and convenience due to selectable neutral disconnect
  - Disconnect unit for the neutral busbar, version ...NT-D-SL
  - Internal disconnect of the neutral potential, version ...NTM-D-SL

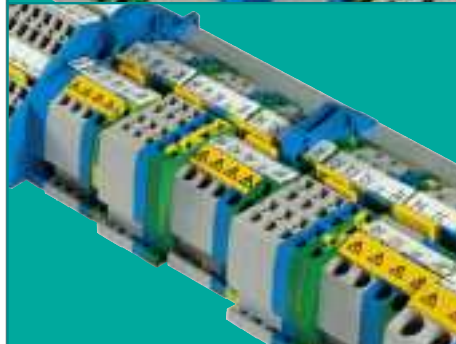

**Standard  
DIN rail terminal  
blocks for junction  
boxes**

### **Power supply and distribution**

- Incoming supply, power distribution in sub-systems and routing to other sub-systems.
- Ground contact to the mounting rail is made immediately after snap-on of the ground block.
- PEN function with 2 pole cross connector and ground connection through neutral feed-through block.
- Safe disconnect of the neutral potential from the neutral busbar due to selectable neutral disconnect unit.



**Operation of the terminal blocks**

### **Convenient switching and operation**

- Convenient operation due to screwless spring connection technology without screws in inclined design. Wire entry and terminal operation are performed in parallel on one tier.
- Permanently secure and dynamic connection due to the spring connection technology with tension spring system and separation of electrical and mechanical functions.
- Safety and user-friendly operation even when the neutral conductor is disconnected from the neutral busbar by means of a disconnect unit to perform an insulation test with visual control.



**Mixed  
and single-sort  
application**

### **Combinations within the system**

- A combination of the installation blocks with standard DIN rail terminal blocks and different connection styles.
- Example:
  - Incoming supply and circuit wiring with the screwless spring connection of **fasis** BIT throughout.
  - Incoming supply with the proven **selos** BIT screw connection style and circuit wiring with the compact **fasis** BIT installation blocks.

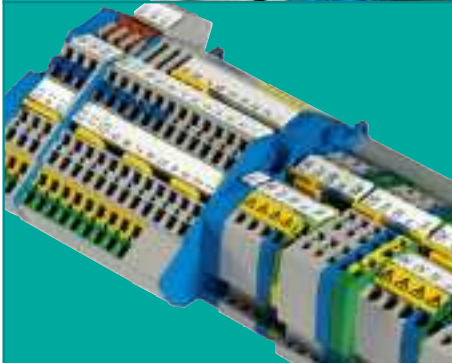

### Accumulating and isolating the neutral potential

- Combining the neutral conductors of the individual circuits through the neutral busbar up to a current load of 140 A.
- Connection of the busbar's neutral potential to the ground-fault circuit interrupter or supply for the distribution unit with connector clamp WAK in 16 or 35 mm<sup>2</sup>.
- Safe and stable 3D positioning of the neutral busbar through busbar support with end clamping function.

### Jumpering the terminal blocks

- Touchproof jumpering with insulated cross connector.
- High resistance of the cross connectors to the "rated current" of the rated cross section.
- High resistance to mechanical wear.
  - Due to a separation of the mechanical and electrical functions
  - Protection against excessive bending of the contact spring due to its structural design

### Marking live potentials

- Marking of live components for greater safety.
- For terminal blocks that remain live when the main switch is disconnected (DIN VDE 0113).
- The snap-on cover can only be removed with a tool.

### Clearly marking all clamping points

- Marking tags easily readable even with the wires connected.
- Clear assignment of wire to clamping point during wiring.
- Simplified troubleshooting for servicing.
- Individual marking with the **wiemarc** and **wieplot** marking systems.

### Selection of high-quality materials

- Special alloys enable low contact resistance and provide a gas-tight contact area:
  - Clamping spring: stainless CrNi steel
  - Busbar: tin-plated copper
- Polyamide has excellent electrical, chemical and mechanical characteristics:
  - Temperature resistance: up to 120 °C
  - Creepage resistance: CTI 600
  - Flammability class: self-extinguishing, UL94-V0

DIN rail terminal blocks for junction boxes with tension spring connection, type *WKF/WKIF*

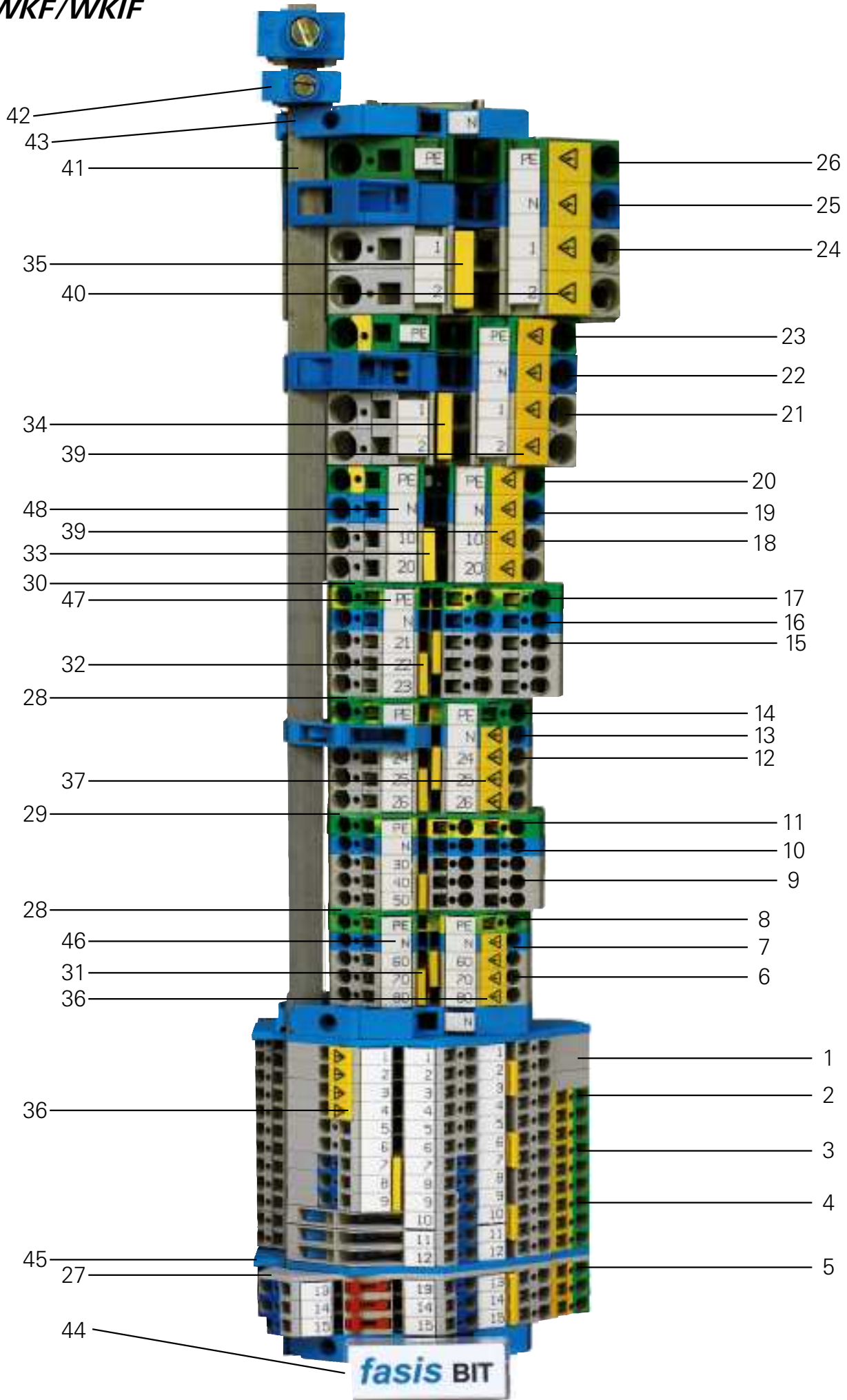

Item	Description	Type	Part No.
1	Installation block	WKIF 2,5 D-D	56.703.9753.0
2	Installation block	WKIF 2,5 D-D-SL	56.703.9853.0
3	Installation block	WKIF 2,5 N-D-SL	56.703.9453.0
4	Installation block	WKIF 2,5 NT-D-SL	56.703.9553.0
5	Installation block	WKIF 2,5 NTM-D-SL	56.703.8653.0
6	Feed-through block	WKF 2,5 /35	56.703.0053.0
7	Feed-through block, blue	WKF 2,5 /35 BLAU	56.703.0053.6
8	Ground block	WKF 2,5 SL/35	56.703.9053.0
9	Duo feed-through block	WKF 2,5 D1/2/35	56.703.5053.0
10	Duo feed-through block, blue	WKF 2,5 D1/2/35 BLAU	56.703.5053.6
11	Duo ground block	WKF 2,5 D1/2/SL/35	56.703.9353.0
12	Feed-through block	WKF 4 /35	56.704.0053.0
13	Neutral disconnect block	WKF 4 NT/35	56.704.8153.0
14	Ground block	WKF 4 SL/35	56.704.9053.0
15	Duo feed-through block	WKF 4 D1/2/35	56.704.5053.0
16	Duo feed-through block, blue	WKF 4 D1/2/35 BLAU	56.704.5053.6
17	Duo feed-through block	WKF 4 D1/2/SL/35	56.704.9353.0
18	Feed-through block	WKF 6 /35	56.706.0053.0
19	Neutral disconnect block	WKF 6 /35 BLAU	56.706.0053.6
20	Ground block	WKF 6 SL/35	56.706.9053.0
21	Feed-through block	WKF 10 /35	56.710.0053.0
22	Neutral disconnect block	WKF 10 NT/35	56.710.8153.0
23	Ground block	WKF 10 SL/35	56.710.9053.0
24	Feed-through block	WKIF 16/2 /35	56.716.1155.0
25	Neutral disconnect block	WKIF 16/2 NT/35	56.716.8155.0
26	Ground block	WKIF 16/2 SL/35	56.716.9155.0
27	End plate	APIF 2,5 TM	07.312.8053.0
28	End plate, green	APF 2,5-4 GRÜN	07.312.2153.7
29	End plate, green	APF 2,5 D1/2 GRÜN	07.312.2353.0
30	End plate, green	APF 4 D1/2 GRÜN	07.312.4853.7
31	Cross connector, 2 pole	IVB-WKF 2,5-2	Z7.280.6227.0
32	Cross connector, 2 pole	IVB-WKF 4-2	Z7.261.1227.0
33	Cross connector, 2 pole	IVB-WKF 6-2	Z7.282.4227.0
34	Cross connector, 2 pole	IVB-WKF 10-2	Z7.283.4227.0
35	Cross connector, 2 pole	IVB-WKF 16-2	Z7.284.4227.0
36	Cover with warning symbol	ADF 2,5/4 GELB	04.343.6053.8
37	Cover with warning symbol	ADF 4/4 GELB	04.343.6153.8
38	Cover with warning symbol	ADF 6/4 GELB	04.343.6253.8
39	Cover with warning symbol	ADF 10/4 GELB	04.343.6453.8
40	Cover with warning symbol	ADF 16/4 GELB	04.343.6653.8
41	Busbar, E-Cu, 10 x 3mm, tin-plated	9813 M SN	98.290.1000.0
42	Connector clamp f. busbar	WAK 16/2 BLAU	30.494.3021.6
43	Busbar support as end clamp	WKIF SH/E/35	Z1.108.8453.0
44	Group marking tag with carrier	BS/R	Z4.243.8453.0
45	Busbar support	WKIF SH/35	01.108.7653.0
46	Marking strips 5 mm	9705 A/5/10	04.242.5053.0
47	Marking strips 6 mm	9705 A/6/10	04.242.6053.0
48	Marking strips 8 mm	9705 A/8/10	04.242.8053.0

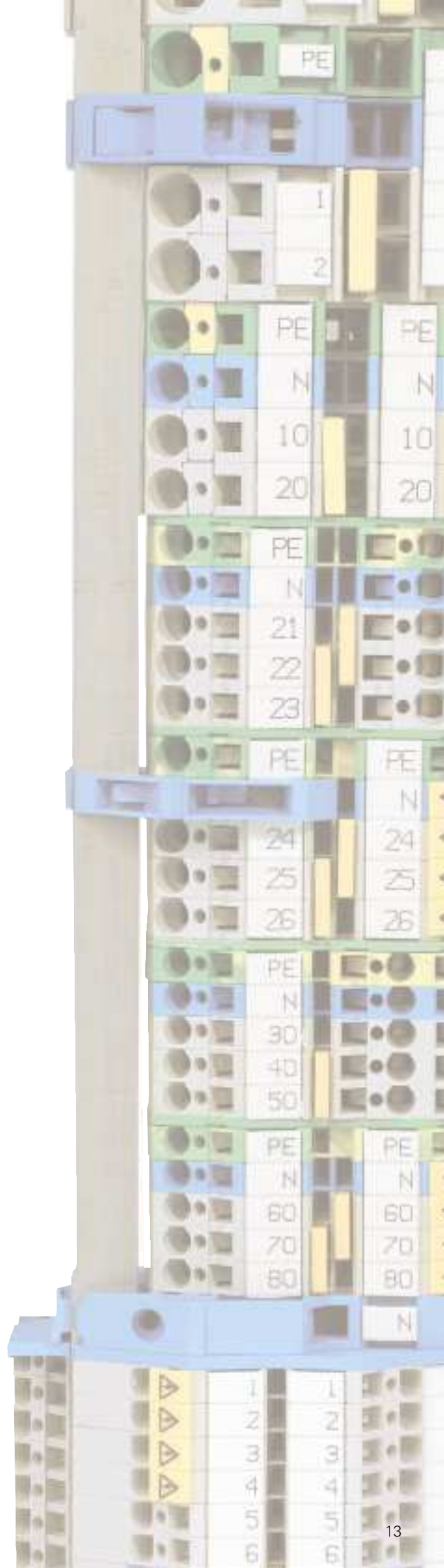

# Feed-through blocks for junction boxes with tension spring connection, type **WKF**

\*) In order to maintain the proper isolation distances, the open side of a feed-through terminal block as well as both sides of a jumper are to be covered by partitions.

1) Please note the mounting instructions.

2) Do not use in Ex environments.

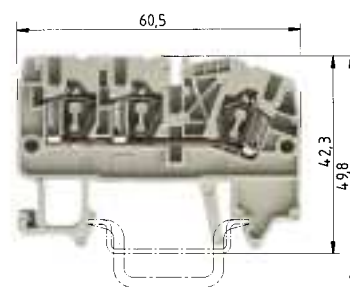
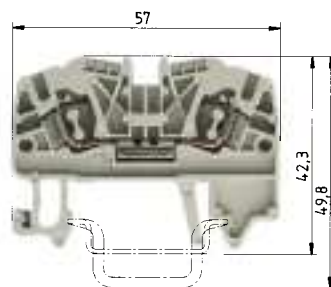

0344 II 2GD IM2

Ex e I/II

EN 60 947-7-1:2002

UL ratings

field/factory wiring

CSA ratings

KEMA 01 ATEX 2087 U<sup>1)</sup> EN 60079-0/EN 60079-7

Width

Wire strip length

Approvals

## WKF 2,5/35

fine-stranded solid	V	A
0.13 – 2.5 mm <sup>2</sup> 0.13 – 4 mm <sup>2</sup>	800 V/8 kV/3	24
No. 22-12 AWG	600 V	20/30
No. 24-12 AWG	600 V	25
0.5 – 2.5 mm <sup>2</sup> 0.5 – 4 mm <sup>2</sup>	690 V <sup>*)</sup>	22
5 mm		11 mm

ATEX RINA LR BV

## WKF 2,5 D1/2/35

fine-stranded solid	V	A
0.13 – 2.5 mm <sup>2</sup> 0.5 – 4 mm <sup>2</sup>	800 V/8 kV/3	24
No. 22-12 AWG	600 V	20/30
No. 24-12 AWG	600 V	25
0.5 – 2.5 mm <sup>2</sup> 0.5 – 4 mm <sup>2</sup>	690 V <sup>*)</sup>	22
5 mm		11 mm

ATEX RINA LR BV

		Type	Part No.	Std. Pack	Type	Part No.	Std. Pack
Feed-through block	gray	WKF 2,5/35	56.703.0053.0	100			
Feed-through block	blue	WKF 2,5/35 BLAU	56.703.0053.6	100			
Duo feed-through block	gray						
Duo feed-through block	blue						
Supply block	gray						
Accessories							
1. Mounting rail 35, DIN rail 7.5 mm high	L = 2 m	35x27x7,5 EN 60715	98.300.0000.0	1			
Mounting rail 35, DIN rail 15 mm high	L = 2 m	35x24x15 EN 60715	98.360.0000.0	1			
2. End clamp TS 35, with screw <sup>2)</sup>	8 mm wide	9708/2 S35	Z5.522.8553.0	100			
End clamp TS 35, without screw	8 mm wide	WEF 1/35	Z5.523.9353.0	100			
3. End plate	gray	APF 2,5 – 4	07.312.2153.0	10			
	blue	APF 2,5 – 4 BLAU	07.312.2153.6	10			
4. Partition	gray	TWF 2,5 – 4	07.312.2253.0	10			
	blue	TWF 2,5 – 4 BLAU	07.312.2253.6	10			
5. Cross connector, insulated	2 pole	IVB WKF 2,5 – 2	Z7.280.6227.0	10			
	3 pole	IVB WKF 2,5 – 3	Z7.280.6327.0	10			
	4 pole	IVB WKF 2,5 – 4	Z7.280.6427.0	10			
	5 pole	IVB WKF 2,5 – 5	Z7.280.6527.0	10			
	6 pole	IVB WKF 2,5 – 6	Z7.280.6627.0	10			
	7 pole	IVB WKF 2,5 – 7	Z7.280.6727.0	20			
	8 pole	IVB WKF 2,5 – 8	Z7.280.6827.0	20			
	9 pole	IVB WKF 2,5 – 9	Z7.280.6927.0	20			
	10 pole	IVB WKF 2,5 – 10	Z7.280.7027.0	20			
6. Wire entry guide	0.13 – 0.2 mm <sup>2</sup>	LEL 2,5/1 WEISS	05.561.6553.0	100			
	0.25 – 0.5 mm <sup>2</sup>	LEL 2,5/2 GRAU	05.561.6653.0	100			
	0.75 – 1.0 mm <sup>2</sup>	LEL 2,5/3 SCHWARZ	05.561.6753.0	100			
7. Cover with warning symbol over 4 blocks		ADF 2,5/4 GELB	04.343.6053.8	10			
8. Busbar, E-Cu 10 x 3 mm, tin-plated	L = 1 m						
9. Connector clamp for busbar	8.5 mm wide						
	12.5 mm wide						
	17 mm wide						
10. Busbar support	8 mm wide						
11. Screwdriver, uninsulated		DIN 5264 B 0,6x3,5	06.502.4000.0	5			
Marking accessories see page 52-54							

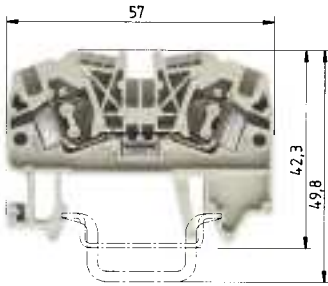

**WKF 4/35**

fine-stranded solid V A  
 0.13 – 4 mm<sup>2</sup> 0.13 – 6 mm<sup>2</sup> 800 V/8 kV/3 32  
 No. 22-10 AWG 600 V 20/30  
 No. 22-10 AWG 600 V 35  
 0.5 – 4 mm<sup>2</sup> 0.5 – 6 mm<sup>2</sup> 690 V\*) 28  
 6 mm 11 mm



Potential-distribution					
	one side		both sides		
Jumpering	single	double	single	double	
WKF 2.5	I <sub>max</sub>	48	68	72	76
	I <sub>Nblock</sub>	24	24	24	24
WKF 4	I <sub>max</sub>	64	76	76	76
	I <sub>Nblock</sub>	32	32	32	32

$$I_{max} = \sum I_n \leq \sum I_{Nblock}$$

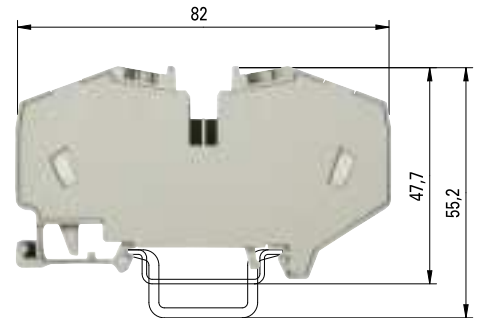

**WKF 16/35 PV/WKF**

fine-stranded solid/stranded V A  
 4 – 16 mm<sup>2</sup> 4 – 16 mm<sup>2</sup> 800 V/8 kV/3 76<sup>3)</sup>  
 No. 12-6 AWG 600 V 20  
 No. 12-6 AWG 600 V 20  
 4 – 16 mm<sup>2</sup> 4 – 16 mm<sup>2</sup> 690 V 69  
 12 mm 11 mm



Type	Part No.	Std. Pack	Type	Part No.	Std. Pack
WKF 4/35	56.704.0053.0	100			
WKF 4/35 BLAU	56.704.0053.6	100			
			WKF 16/35 PV/WKF	56.716.0153.0	20
35x27x7,5 EN 60715	98.300.0000.0	1	35x27x7,5 EN 60715	98.300.0000.0	1
35x24x15 EN 60715	98.360.0000.0	1	35x24x15 EN 60715	98.360.0000.0	1
9708/2 S35	Z5.522.8553.0	100	9708/2 S35	Z5.522.8553.0	100
WEF 1/35	Z5.523.9353.0	100	WEF 1/35	Z5.523.9353.0	100
APF 2,5 – 4	07.312.2153.0	10			
APF 2,5 – 4 BLAU	07.312.2153.6	10			
TWF 2,5 – 4	07.312.2253.0	10			
TWF 2,5 – 4 BLAU	07.312.2253.6	10			
IVB WKF 4 – 2	Z7.261.1227.0	10	} depending on the terminal block IVB WKF 2,5... 5 mm spacing IVB WKF 4... 6 mm spacing		
IVB WKF 4 – 3	Z7.261.1327.0	10			
IVB WKF 4 – 4	Z7.261.1427.0	10			
IVB WKF 4 – 5	Z7.261.1527.0	10			
IVB WKF 4 – 6	Z7.261.1627.0	10			
IVB WKF 4 – 7	Z7.261.1727.0	20			
IVB WKF 4 – 8	Z7.261.1827.0	20			
IVB WKF 4 – 9	Z7.261.1927.0	20			
IVB WKF 4 – 10	Z7.261.2027.0	20			
LEL 4/1 WEISS	05.561.8553.0	100			
LEL 4/2 GRAU	05.561.8653.0	100			
LEL 4/3 SCHWARZ	05.561.8753.0	100			
ADF 4/4 GELB	04.343.6153.8	10	ADF 16/4 GELB	04.343.6653.8	10
DIN 5264 B 0,6x3,5	06.502.4000.0	5	DIN 5264 B 1,0x5,5	06.502.4200.0	5

# Feed-through blocks for junction boxes with tension spring connection, type *WKF/WKIF*

\*) In order to maintain the proper isolation distances, the open side of a feed-through terminal block as well as both sides of a jumper are to be covered by partitions.  
 1) Please note the mounting instructions.  
 2) Do not use in Ex environments.

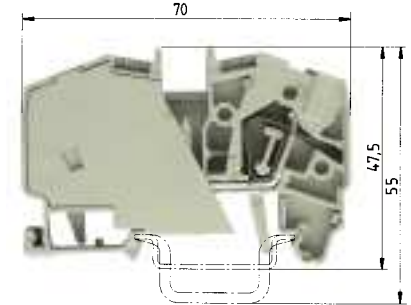
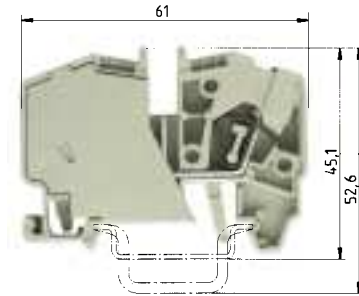

0344 II 2GD IM2  
 Ex e I/II  
 EN 60 947-7-1:2002  
 UL ratings field/factory wiring  
 CSA ratings  
 KEMA 01 ATEX 2087 U<sup>1)</sup> EN 60079-0/EN 60079-7  
 Width Wire strip length  
 Approvals

### WKF 6/35

fine-stranded	solid		V	A
0.5 – 6 mm <sup>2</sup>	0.5 – 6 mm <sup>2</sup>	800 V/8 kV/3	41	
No. 20-10 AWG		600 V	40	
No. 20-10 AWG		600 V	47	
0.5 – 6 mm <sup>2</sup>	0.5 – 6 mm <sup>2</sup>	750 V	38	
8 mm				12 mm

ATEX RINA LR BV RU IECEx

### WKF 10/35

fine-stranded	solid		V	A
2.5 – 10 mm <sup>2</sup>	2.5 – 10 mm <sup>2</sup>	800 V/8 kV/3	57	
No. 14-8 AWG		600 V	55	
No. 14-8 AWG		600 V	65	
2.5 – 10 mm <sup>2</sup>	2.5 – 10 mm <sup>2</sup>	750 V	54	
10 mm				13 mm

ATEX RINA LR BV RU IECEx

		Type	Part No.	Std. Pack	Type	Part No.	Std. Pack
Feed-through block	gray	WKF 6/35	56.706.0053.0	100	WKF 10/35	56.710.0053.0	50
Feed-through block	blue	WKF 6/35 BLAU	56.706.0053.6	100	WKF 10/35 BLAU	56.710.0053.6	50
Neutral disconnecter block	blue						
Ground block	green/yellow						
Accessories							
1. Mounting rail 35, DIN rail 7.5 mm high	L = 2 m	35x27x7,5 EN 60715	98.300.0000.0	1	35x27x7,5 EN 60715	98.300.0000.0	1
Mounting rail 35, DIN rail 15 mm high	L = 2 m	35x24x15 EN 60715	98.360.0000.0	1	35x24x15 EN 60715	98.360.0000.0	1
2. End clamp TS 35, with screw <sup>2)</sup>	8 mm wide	9708/2 S35	Z5.522.8553.0	100	9708/2 S35	Z5.522.8553.0	100
End clamp TS 35, without screw	8 mm wide	WEF 1/35	Z5.523.9353.0	100	WEF 1/35	Z5.523.9353.0	100
3. End plate	gray						
	blue						
4. Partition	gray						
	blue						
5. Cross connector, insulated	2 pole	IVB WKF 6 – 2	Z7.282.4227.0	10	IVB WKF 10 – 2	Z7.283.8227.0	10
	3 pole						
	4 pole						
	5 pole						
	6 pole						
	7 pole						
	8 pole						
	9 pole						
	10 pole						
6. Wire entry guide	0.13 – 0.2 mm <sup>2</sup>						
	0.25 – 0.5 mm <sup>2</sup>						
	0.75 – 1.0 mm <sup>2</sup>						
7. Cover with warning symbol over 4 blocks		ADF 6/4 GELB	04.343.6253.8	10	ADF 10/4 GELB	04.343.6453.8	10
8. Busbar, E-Cu 10x3 mm, tin-plated	L = 1 m	9813 M SN	98.290.1000.0	1	9813 M SN	98.290.1000.0	1
9. Connector clamp for busbar	8.5 mm wide						
	12.5 mm wide						
	17 mm wide						
10. Busbar support	8 mm wide	WKIF SH/E/35	Z1.108.8453.0	100	WKIF SH/E/35	Z1.108.8453.0	100
11. Screwdriver uninsulated		DIN 5264 B 0,8x4	06.502.4100.0	5	DIN 5264 B 0,8x4	06.502.4100.0	5
Marking accessories see page 52-54							



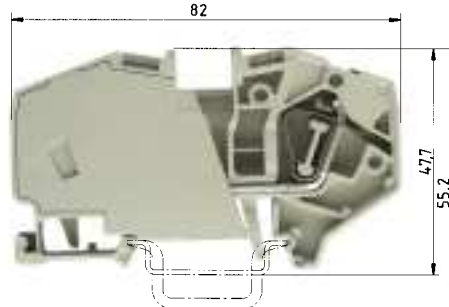
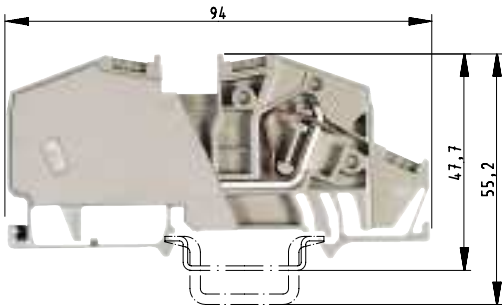

centered on the mounting rail

**WKIF 16/1 /35**

fine-stranded	stranded	V	A
4 – 16 mm <sup>2</sup>	4 – 16 mm <sup>2</sup>	800 V/8 kV/3	76

12 mm

16 mm

**WKF 16/35**

fine-stranded	stranded	V	A
4 – 16 mm <sup>2</sup>	4 – 16 mm <sup>2</sup>	800 V/8 kV/3	76

No. 24-4 AWG		600 V	75
--------------	--	-------	----

No. 12-4 AWG		600 V	78
--------------	--	-------	----

4 – 16 mm <sup>2</sup>	4 – 16 mm <sup>2</sup>	690 V	69
------------------------	------------------------	-------	----

12 mm

15 mm

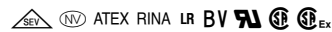

Type	Part No.	Std. Pack	Type	Part No.	Std. Pack
WKIF 16/1 /35	56.716.1155.0	50	WKF 16/35	56.716.0053.0	50
WKIF 16/1 /35 BLAU	56.716.1155.6	50	WKF 16/35 BLAU	56.716.0053.6	50
35x27x7,5 EN 60715	98.300.0000.0	1	35x27x7,5 EN 60715	98.300.0000.0	1
35x24x15 EN 60715	98.360.0000.0	1	35x24x15 EN 60715	98.360.0000.0	1
9708/2 S35	Z5.522.8553.0	100	9708/2 S35	Z5.522.8553.0	100
WEF 1/35	Z5.523.9353.0	100	WEF 1/35	Z5.523.9353.0	100
IVB WKF 16 – 2	Z7.284.4227.0	10	IVB WKF 16 – 2	Z7.284.4227.0	10
9813 M SN	98.290.1000.0	1	ADF 16/4 GELB	04.343.6653.8	10
WKIF SH/E/35	Z1.108.8453.0	100	DIN 5264 B 1x5,5	06.502.4200.0	5
DIN 5264 B 1x5,5	06.502.4200.0	5			

## Neutral disconnect blocks for junction boxes with tension spring connection, type *WKF/WKIF*

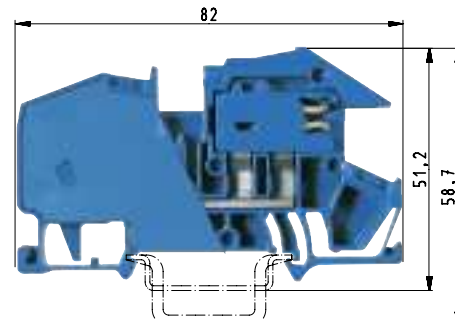
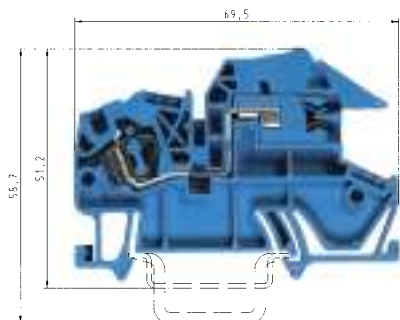

### WKF 4 NT/35

fine-stranded solid V A  
0.13 – 4 mm<sup>2</sup> 0.13 – 6 mm<sup>2</sup> 400 V/6 kV/3 25

### WKF 10 NT/35

fine-stranded stranded V A  
2.5 – 10 mm<sup>2</sup> 2.5 – 10 mm<sup>2</sup> 400 V/6 kV/3 57

EN 60 947-7-1; 1991/DIN VDE 0611 T1/08.92

UL ratings field/factory wiring

CSA ratings

Width Wire strip length

Approvals **SE** 6 mm 11 mm 10 mm 13 mm

	Type	Part No.	Std. Pack	Type	Part No.	Std. Pack
Feed-through block gray						
Feed-through block blue						
Neutral disconnect block blue	WKF 4 NT/35	56.704.8153.0	100	WKF 10 NT/35	56.710.8153.0	50
Connector clamp for Cu busbar blue						
	unplated					
<b>Accessories</b>						
1. Mounting rail 35, DIN rail 7.5 mm high L = 2 m	35x27x7,5 EN 60715	98.300.0000.0	1	35x27x7,5 EN 60715	98.300.0000.0	1
Mounting rail 35, DIN rail 15 mm high L = 2 m	35x24x15 EN 60715	98.360.0000.0	1	35x24x15 EN 60715	98.360.0000.0	1
2. End clamp TS 35, with screw 8 mm wide	9708/2 S35	Z5.522.8553.0	100	9708/2 S35	Z5.522.8553.0	100
End clamp TS 35, without screw 8 mm wide	WEF 1/35	Z5.523.9353.0	100	WEF 1/35	Z5.523.9353.0	100
3. End plate gray						
blue	APF 4 NT	07.312.5653.0	10			
<b>4. Partition</b>						
5. Cross connector, insulated 2 pole	IVB WKF 4 – 2	Z7.261.1227.0	10	IVB WKF 10 – 2	Z7.283.8227.0	10
3 pole	IVB WKF 4 – 3	Z7.261.1327.0	10			
4 pole	IVB WKF 4 – 4	Z7.261.1427.0	10			
5 pole	IVB WKF 4 – 5	Z7.261.1527.0	10			
6 pole	IVB WKF 4 – 6	Z7.261.1627.0	10			
7 pole	IVB WKF 4 – 7	Z7.261.1727.0	20			
8 pole	IVB WKF 4 – 8	Z7.261.1827.0	20			
9 pole	IVB WKF 4 – 9	Z7.261.1927.0	20			
10 pole	IVB WKF 4 – 10	Z7.261.2027.0	20			
6. Wire entry guide 0.13 – 0.2 mm <sup>2</sup>	LEL 4/1 WEISS	05.561.8553.0	100			
0.25 – 0.5 mm <sup>2</sup>	LEL 4/2 GRAU	05.561.8653.0	100			
0.75 – 1.0 mm <sup>2</sup>	LEL 4/3 SCHWARZ	05.561.8753.0	100			
7. Cover with warning symbol over 4 blocks	ADF 4/4 GELB	04.343.6153.8	10	ADF 10/4 GELB	04.343.6453.8	10
8. Busbar, E-Cu 10 x 3 mm, blank, I <sub>N</sub> = 140 A L = 1 m						
E-Cu 10 x 3 mm, tin-plated, I <sub>N</sub> = 140 A L = 1 m	9813 M SN	98.290.1000.0	1	9813 M SN	98.290.1000.0	1
9. Connector clamp for busbar 8.5 mm wide	WAK 16/2 BLAU	30.494.3021.6	100	WAK 16/2 BLAU	30.494.3021.6	100
12.5 mm wide	WAK 35/2 BLAU	30.494.4021.6	100	WAK 35/2 BLAU	30.494.4021.6	100
17 mm wide	WAK 35/2	30.494.4121.0	50	WAK 35/2	30.494.4121.0	50
10. Busbar support 8 mm wide	WKIF SH/E/35	Z1.108.8453.0	100	WKIF SH/E/35	Z1.108.8453.0	100
11. Screwdriver uninsulated	DIN 5264 B 0,6x3,5	06.502.4000.0	5	DIN 5264 B 0,8x4	06.502.4100.0	5
12. Switching disable for neutral disconnect switch				SPNT	05.565.6855.9	10

Marking accessories see page 52-54

# Connector clamp for Cu busbar (10 x 3 mm), type WAK

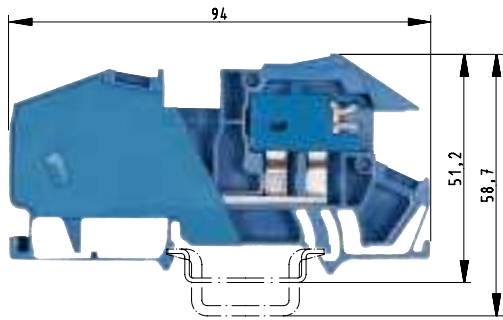

EN 60 998-2-1 CCA/CH

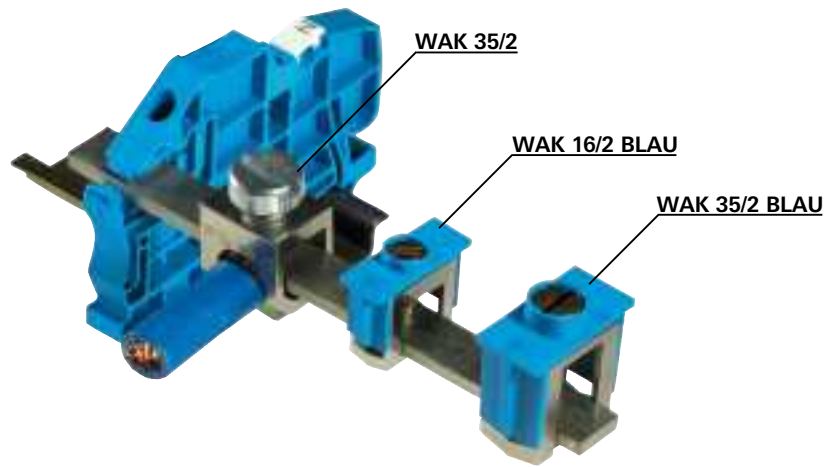

EN 60 998-2-1 CCA/CH

### WKIF 16/1 NT/35

fine-stranded 4 – 16 mm<sup>2</sup>    stranded 4 – 16 mm<sup>2</sup>    V 400 V/6 kV/3    A 76

12 mm

15 mm

### WAK 16/2

fine-stranded 1.5 – 16 mm<sup>2</sup>    stranded 10 – 16 mm<sup>2</sup>    V    A 76

8,4 mm



### WAK 35/2

fine-stranded 16 – 35 mm<sup>2</sup>    stranded 16 – 35 mm<sup>2</sup>    V    A 125

17 mm



14 mm

Type	Part No.	Std. Pack	Type	Part No.	Std. Pack	Type	Part No.	Std. Pack
WKIF 16/1 NT/35	56.716.8155.0	50	WAK 16/2 BLAU/VO	30.494.3021.6	100	WAK 35/2 BLAU	30.494.4021.0	50
						WAK 35/2	30.494.4121.0	50
35x27x7,5 EN 60715	98.300.0000.0	1						
35x24x15 EN 60715	98.360.0000.0	1						
9708/2 S35	Z5.522.8553.0	100						
WEF 1/35	Z5.523.9353.0	100						
IVB WKIF 16 – 2	Z7.284.4227.0	10						
ADF 16/4 GELB	04.343.6653.8	10						
			9813 M	98.290.0000.0	1	9813 M	98.290.0000.0	1
9813 M SN	98.290.1000.0	1	9813 M SN	98.290.1000.0	1	9813 M SN	98.290.1000.0	1
WAK 16/2 BLAU	30.494.3021.6	100						
WAK 35/2 BLAU	30.494.4021.6	100						
WAK 35/2	30.494.4121.0	50						
WKIF SH/E/35	Z1.108.8453.0	100	WKIF SH/E/35	Z1.108.8453.0	100	WKIF SH/E/35	Z1.108.8453.0	100
DIN 5264 B 1x5,5	06.502.4200.0	5						
SPNT	05.565.6855.9	10						

# Ground blocks for junction boxes with tension spring connection, type WKF

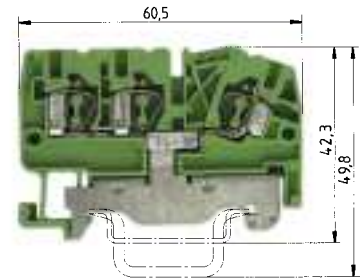
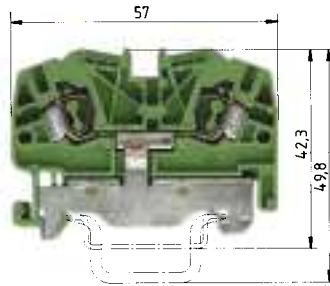

- \*<sup>1)</sup> In order to maintain the proper isolation distances, the open side of a feed-through terminal block as well as both sides of a jumper are to be covered by partitions.
- <sup>2)</sup> Please note the mounting instructions.
- <sup>3)</sup> Do not use in Ex environments.
- <sup>4)</sup> For the current carrying capability of the mounting rail see **facts** & DATA
- <sup>5)</sup> Ratings for adjacent feed-through blocks of the same series and size.

0344 II 2GD IM2  
 Ex e I/II  
 EN 60 947-7-2:2002  
 UL ratings field/factory wiring  
 CSA ratings  
 KEMA 01 ATEX 2087 U<sup>1)</sup> EN 60079-0/EN 60079-7  
 Width Wire strip length  
 Approvals

### WKF 2,5 SL/35

fine-stranded solid V A  
 0.13 – 2.5 mm<sup>2</sup> 0.13 – 4 mm<sup>2</sup> 800 V/8 kV/3<sup>4)</sup> <sup>3)</sup>  
 No. 22-12 AWG 600 V  
 No. 24-12 AWG 600 V  
 0.5 – 2.5 mm<sup>2</sup> 0.5 – 4 mm<sup>2</sup> \*)  
 5 mm 11 mm

### WKF 2,5 D1/2/SL/35

fine-stranded solid V A  
 0.13 – 2.5 mm<sup>2</sup> 0.5 – 4 mm<sup>2</sup> 800 V/8 kV/3<sup>4)</sup> <sup>3)</sup>  
 No. 22-12 AWG 600 V 20/30  
 No. 24-12 AWG 600 V 25  
 0.5 – 2.5 mm<sup>2</sup> 0.5 – 4 mm<sup>2</sup> \*)  
 5 mm 11 mm

		Type	Part No.	Std. Pack	Type	Part No.	Std. Pack
Ground block	yellow/green	WKF 2,5 SL/35	56.703.9053.0	100			
Duo ground block	yellow/green				WKF 2,5/D1/2/SL/35	56.703.9353.0	100
<b>Accessories</b>							
1. Mounting rail 35, DIN rail 7.5 mm high	L = 2 m	35x27x7,5 EN 60715	98.300.0000.0	1	35x27x7,5 EN 60715	98.300.0000.0	1
Mounting rail 35, DIN rail 15 mm high	L = 2 m	35x24x15 EN 60715	98.360.0000.0	1	35x24x15 EN 60715	98.360.0000.0	1
2. End clamp TS 35, with screw <sup>2)</sup>	8 mm wide	9708/2 S35	Z5.522.8553.0	100	9708/2 S35	Z5.522.8553.0	100
End clamp TS 35, without screw	8 mm wide	WEF 1/35	Z5.523.9353.0	100	WEF 1/35	Z5.523.9353.0	100
3. End plate	gray						
	blue						
	green	APF 2,5 – 4 GRÜN	07.312.2153.7	10	APF 2,5 D1/2 GRÜN	07.312.2353.7	10
4. Partition	gray						
	blue						
5. Cross connector, insulated	2 pole						
	3 pole						
	4 pole						
	5 pole						
	6 pole						
	7 pole						
	8 pole						
	9 pole						
	10 pole						
6. Wire entry guide	0.13 – 0.2 mm <sup>2</sup>	LEL 2,5/1 WEISS	05.561.6553.0	100	LEL 2,5/1 WEISS	05.561.6553.0	100
	0.25 – 0.5 mm <sup>2</sup>	LEL 2,5/2 GRAU	05.561.6653.0	100	LEL 2,5/2 GRAU	05.561.6653.0	100
	0.75 – 1.0 mm <sup>2</sup>	LEL 2,5/3 SCHWARZ	05.561.6753.0	100	LEL 2,5/3 SCHWARZ	05.561.6753.0	100
7. Cover with warning symbol over 4 blocks					ADF 2,5/4 GELB	04.343.6053.8	10
8. Busbar, E-Cu 10x3 mm, tin-plated	L = 1 m						
9. Connector clamp for busbar	8.5 mm wide						
	12.5 mm wide						
	17 mm wide						
10. Busbar support	8 mm wide						
11. Screwdriver uninsulated		DIN 5264 B 0,6x3,5	06.502.4000.0	5	DIN 5264 B 0,6x3,5	06.502.4000.0	5
Marking accessories see page 52-54							

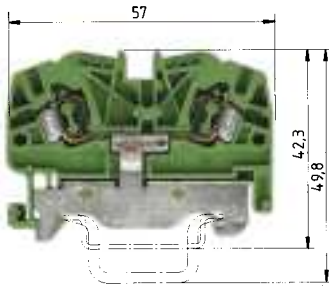

**WKF 4 SL/35**

fine-stranded solid V A  
 0.13 – 4 mm<sup>2</sup> 0.13 – 6 mm<sup>2</sup> 800 V/8 kV/3<sup>4)</sup> 3)  
 No. 22-10 AWG 600 V  
 No. 22-10 AWG 600 V  
 0.5 – 4 mm<sup>2</sup> 0.5 – 6 mm<sup>2</sup> \*)  
 6 mm 11 mm



Type	Part No.	Std. Pack	
WKF 4 SL/35	56.704.9053.0	100	
35x27x7,5 EN 60715	98.300.0000.0	1	
35x24x15 EN 60715	98.360.0000.0	1	
9708/2 S35	Z5.522.8553.0	100	
WEF 1/35	Z5.523.9353.0	100	
APF 2,5 – 4 GRÜN	07.312.2153.7	10	
LEL 4/1 WEISS	05.561.8553.0	100	
LEL 4/2 GRAU	05.561.8653.0	100	
LEL 4/3 SCHWARZ	05.561.8753.0	100	
DIN 5264 B 0,6x3,5	06.502.4000.0	5	

# Ground blocks for junction boxes with tension spring connection, type *WKF/WKIF*

- \*<sup>1)</sup> In order to maintain the proper isolation distances, the open side of a feed-through terminal block as well as both sides of a jumper are to be covered by partitions.
- <sup>1)</sup> Please note the mounting instructions
- <sup>2)</sup> Do not use in Ex environments.
- <sup>3)</sup> For the current carrying capability of the mounting rail see **facts** & DATA.
- <sup>4)</sup> Ratings for adjacent feed-through blocks of the same series an size.

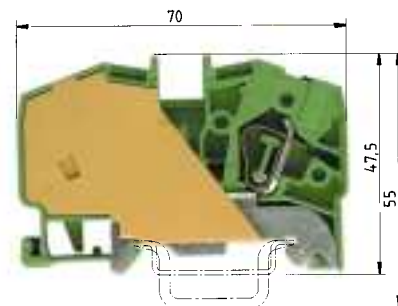
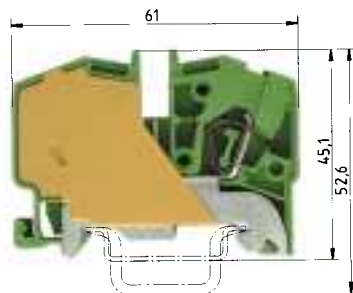

0344 II 2GD IM2  
 Ex e I/II  
 EN 60 947-7-2:2002  
 UL ratings  
 CSA ratings  
 KEMA 01 ATEX 2087 U<sup>1)</sup>  
 Width  
 Approval

field/factory wiring

EN 60079-0/EN 60079-7

Wire strip length

## WKF 6 SL/35

fine-stranded solid V A  
 0.5 – 6 mm<sup>2</sup> 0.5 – 6 mm<sup>2</sup> 800 V/8 kV/3<sup>4)</sup> 41<sup>3)</sup>  
 No. 20-10 AWG 600 V  
 No. 20-10 AWG 600 V  
 0.5 – 6 mm<sup>2</sup> 0.5 – 6 mm<sup>2</sup>  
 8 mm 12 mm



## WKF 10 SL/35

fine-stranded solid V A  
 2.5 – 10 mm<sup>2</sup> 2.5 – 10 mm<sup>2</sup> 800 V/8 kV/3<sup>4)</sup> 3<sup>3)</sup>  
 No. 14-8 AWG 600 V  
 No. 14-8 AWG 600 V  
 2.5 – 10 mm<sup>2</sup> 2.5 – 10 mm<sup>2</sup>  
 10 mm 13 mm



		Type	Part No.	Std. Pack	Type	Part No.	Std. Pack
Ground block	yellow/green	WKF 6 SL/35	56.706.9053.0	100	WKF 10 SL/35	56.710.9053.0	50
<b>Accessories</b>							
1. Mounting rail 35, DIN rail 7.5 mm high	L = 2 m	35x27x7,5 EN 60715	98.300.0000.0	1	35x27x7,5 EN 60715	98.300.0000.0	1
Mounting rail 35, DIN rail 15 mm high	L = 2 m	35x24x15 EN 60715	98.360.0000.0	1	35x24x15 EN 60715	98.360.0000.0	1
2. End clamp TS 35, with screw <sup>2)</sup>	8 mm wide	9708/2 S35	Z5.522.8553.0	100	9708/2 S35	Z5.522.8553.0	100
End clamp TS 35, without screw	8 mm wide	WEF 1/35	Z5.523.9353.0	100	WEF 1/35	Z5.523.9353.0	100
3. End plate	gray						
	blue						
	green						
4. Partition	gray						
	blue						
5. Cross connector, insulated	2 pole						
	3 pole						
	4 pole						
	5 pole						
	6 pole						
	7 pole						
	8 pole						
	9 pole						
	10 pole						
6. Wire entry guide	0.13 – 0.2 mm <sup>2</sup>						
	0.25 – 0.5 mm <sup>2</sup>						
	0.75 – 1.0 mm <sup>2</sup>						
7. Cover with warning symbol over 4 blocks		ADF 6/4 GELB	04.343.6253.8	10	ADF 10/4 GELB	04.343.6453.8	10
8. Busbar, E-Cu 10x3 mm, tin-plated	L = 1 m	9813 M SN	98.290.1000.0	1	9813 M SN	98.290.1000.0	1
9. Connector clamp for busbar	8.5 mm wide	WAK 16/2 BLAU	30.494.3021.6	100	WAK 16/2 BLAU	30.494.3021.6	100
	12.5 mm wide	WAK 35/2 BLAU	30.494.4021.6	100	WAK 35/2 BLAU	30.494.4021.6	100
	17 mm wide	WAK 35/2	30.494.4121.0	50	WAK 35/2	30.494.4121.0	50
10. Busbar support	8 mm wide	WKIF SH/E/35	Z1.108.8453.0	100	WKIF SH/E/35	Z1.108.8453.0	100
11. Screwdriver uninsulated		DIN 5264 B 0,8x4	06.502.4100.0	5	DIN 5264 B 0,8x4	06.502.4100.0	5
Marking accessories see page 52-54							

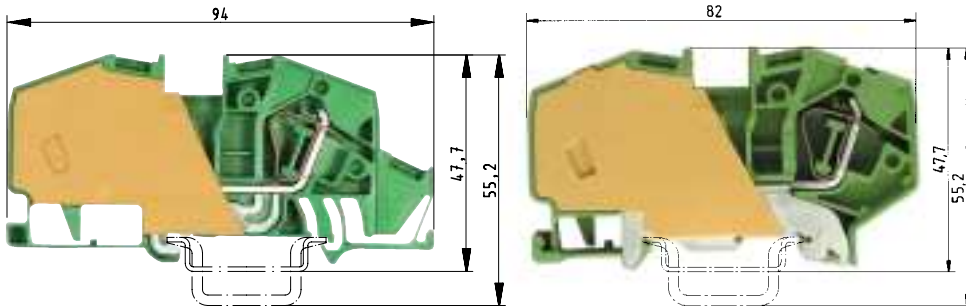

centered on the mounting rail

**WKIF 16/1 SL/35**

fine-stranded    stranded    V    A  
 4 – 16 mm<sup>2</sup>    4 – 16 mm<sup>2</sup>    800 V/8 kV/3    76

12 mm    15 mm

**WKF 16 SL/35**

fine-stranded    stranded    V    A  
 4 – 16 mm<sup>2</sup>    4 – 16 mm<sup>2</sup>    800 V/8 kV/3<sup>4)</sup>    3)

No. 24-4 AWG    600 V  
 No. 12-4 AWG    600 V

4 – 16 mm<sup>2</sup>    4 – 16 mm<sup>2</sup>  
 12 mm    15 mm



Type	Part No.	Std. Pack	Type	Part No.	Std. Pack
WKIF 16/1 SL/35	56.716.9155.0	50	WKF 16 SL/35	56.716.9053.0	50
35x27x7,5 EN 60715	98.300.0000.0	1	35x27x7,5 EN 60715	98.300.0000.0	1
35x24x15 EN 60715	98.360.0000.0	1	35x24x15 EN 60715	98.360.0000.0	1
9708/2 S35	Z5.522.8553.0	100	9708/2 S35	Z5.522.8553.0	100
WEF 1/35	Z5.523.9353.0	100	WEF 1/35	Z5.523.9353.0	100
IVB WKF 16 – 2	Z7.284.4227.0	10			
ADF 16/4 GELB	04.343.6653.8	10			
9813 M SN	98.290.1000.0	1			
WAK 16/2 BLAU	30.494.3021.6	100			
WAK 35/2 BLAU	30.494.4021.6	100			
WAK 35/2	30.494.4121.0	50			
WKIF SH/E/35	Z1.108.8453.0	100			
DIN 5264 B 1x5,5	06.502.4200.0	5	DIN 5264 B 1x5,5	06.502.4200.0	5

# Multi-tier blocks for junction boxes with tension spring connection, type WKIF

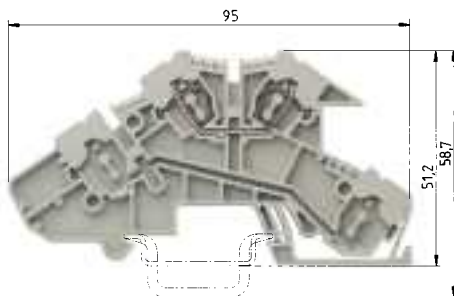

D – line feed-through, upper tier  
Only upper tier equipped.

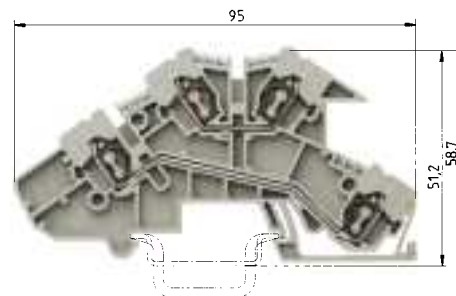

D – line feed-through  
D – line feed-through  
N – neutral feed-through

## WKIF 2,5 D

fine-stranded solid V A  
0.13 – 2.5 mm<sup>2</sup> 0.13 – 4 mm<sup>2</sup> 400 V/6 kV/3 24

pending  
5 mm 11 mm



## WKIF 2,5 D-D WKIF 2,5 N-D

fine-stranded solid V A  
0.13 – 2.5 mm<sup>2</sup> 0.13 – 4 mm<sup>2</sup> 400 V/250 V/4 kV/3 24

pending  
5 mm 11 mm



EN 60947-7-1/DIN VDE 0611 T1  
UL ratings field/factory wiring  
CSA ratings  
Width Wire strip length  
Approvals

		Type	Part No.	Std. Pack	Type	Part No.	Std. Pack
Installation block	gray	WKIF 2,5 D	56.703.9653.0	50	WKIF 2,5 D-D	56.703.9753.0	50
Installation block	gray				WKIF 2,5 N-D	auf Anfrage	
Accessories							
1. Mounting rail 35, DIN rail 7.5 high	L = 2 m	35 x 27 x 7,5 EN 60715	98.300.0000.0	1	35 x 27 x 7,5 EN 60715	98.300.0000.0	1
Mounting rail 35, DIN rail 15 high	L = 2 m	35 x 24 x 15 EN 60715	98.360.0000.0	1	35 x 24 x 15 EN 60715	98.360.0000.0	1
2. End clamp TS 35, with screw	8 mm wide	9708/2 S35	Z5.522.8553.0	100	9708/2 S35	Z5.522.8553.0	100
End clamp TS 35, without screw	8 mm wide	WEF 1/35	Z5.523.9353.0	100	WEF 1/35	Z5.523.9353.0	100
3. End plate	1.5 mm wide	APIF 2,5	07.311.8353.0	10	APIF 2,5	07.311.8353.0	10
4. Partition	gray						
5. Cross connector, insulated	2 pole	IVB WKF 2,5-2	Z7.280.6227.0	10	IVB WKF 2,5-2	Z7.280.6227.0	10
	3 pole	IVB WKF 2,5-3	Z7.280.6327.0	10	IVB WKF 2,5-3	Z7.280.6327.0	10
	4 pole	IVB WKF 2,5-4	Z7.280.6427.0	10	IVB WKF 2,5-4	Z7.280.6427.0	10
	5 pole	IVB WKF 2,5-5	Z7.280.6527.0	10	IVB WKF 2,5-5	Z7.280.6527.0	10
	6 pole	IVB WKF 2,5-6	Z7.280.6627.0	10	IVB WKF 2,5-6	Z7.280.6627.0	10
	7 pole	IVB WKF 2,5-7	Z7.280.6727.0	20	IVB WKF 2,5-7	Z7.280.6727.0	20
	8 pole	IVB WKF 2,5-8	Z7.280.6827.0	20	IVB WKF 2,5-8	Z7.280.6827.0	20
	9 pole	IVB WKF 2,5-9	Z7.280.6927.0	20	IVB WKF 2,5-9	Z7.280.6927.0	20
	10 pole	IVB WKF 2,5-10	Z7.280.7027.0	20	IVB WKF 2,5-10	Z7.280.7027.0	20
6. Wire entry guide	0.13 – 0.2 mm <sup>2</sup>	LEL 2,5/1 WEISS	05.561.6553.0	100	LEL 2,5/1 WEISS	05.561.6553.0	100
	0.25 – 0.5 mm <sup>2</sup>	LEL 2,5/2 GRAU	05.561.6653.0	100	LEL 2,5/2 GRAU	05.561.6653.0	100
	0.75 – 1.0 mm <sup>2</sup>	LEL 2,5/3 SCHWARZ	05.561.6753.0	100	LEL 2,5/3 SCHWARZ	05.561.6753.0	100
7. Cover with warning symbol over 4 blocks		ADF 2,5/4 GELB	04.343.6053.8	10	ADF 2,5/4 GELB	04.343.6053.8	10
8. Busbar, E-Cu 10 x 3 mm, tin-plated	L = 1 m	9813 M Sn	98.290.1000.0	1	9813 M Sn	98.290.1000.0	1
9. Connector clamp for busbar							
	16 mm <sup>2</sup> 8.5 mm wide	WAK 16/2 BLAU	30.494.3021.6	100	WAK 16/2 BLAU	30.494.3021.6	100
	35 mm <sup>2</sup> 12.5 mm wide	WAK 35/2 BLAU	30.494.4021.6	100	WAK 35/2 BLAU	30.494.4021.6	100
	35 mm <sup>2</sup> 17 mm wide	WAK 35/2	30.494.4121.0	50	WAK 35/2	30.494.4121.0	50
10. Busbar support	2 mm wide	WKIF/SH/35	01.108.7653.0	10	WKIF/SH/35	01.108.7653.0	10
Busbar support, as end clamp	8 mm wide	WKIF SH/E/35	Z1.108.8453.0	100	WKIF SH/E/35	Z1.108.8453.0	100
11. Screwdriver, uninsulated		DIN 5264 B 0,6 x 3,5	06.502.4000.0	5	DIN 5264 B 0,6 x 3,5	06.502.4000.0	5
Marking accessories see page 52-54							



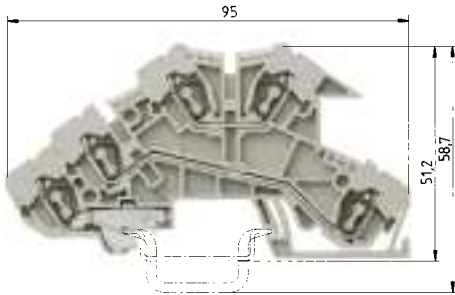

D – line feed-through  
N – neutral feed-through  
SL – ground

**WKIF 2,5 D-D-SL**  
**WKIF 2,5 N-D-SL**

fine-stranded solid V A  
0.13 – 2.5 mm<sup>2</sup> 0.13 – 4 mm<sup>2</sup> 400 V/250 V/4 kV/3 24

being prepared 11 mm  
5 mm

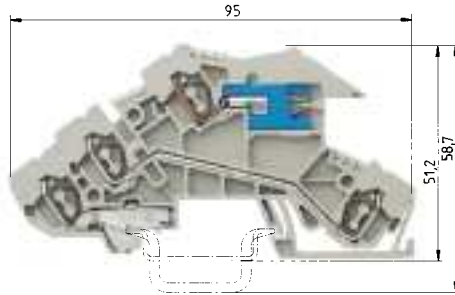

D – line feed-through  
NT – neutral feed-through, disconnectable  
SL – ground

**WKIF 2,5 NT-D-SL**

fine-stranded solid V A  
0.13 – 2.5 mm<sup>2</sup> 0.13 – 4 mm<sup>2</sup> 400 V/250 V/6 kV/3 20

being prepared 11 mm  
5 mm

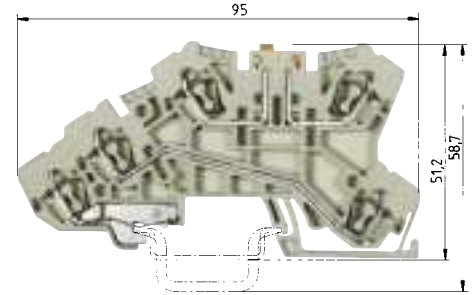

D – line feed-through  
NTM – neutral feed-through, knife edge disconnect  
SL – ground

**WKIF 2,5 NTM-D-SL**

fine-stranded solid V A  
0.13 – 2.5 mm<sup>2</sup> 0.13 – 4 mm<sup>2</sup> 400 V/250 V/6 kV/3 16

being prepared 11 mm  
5 mm

Type	Part No.	Std. Pack	Type	Part No.	Std. Pack	Type	Part No.	Std. Pack
WKIF 2,5 D-D-SL	56.703.9853.0	50	WKIF 2,5 NT-D-SL	56.703.9553.0	50	WKIF 2,5 NTM-D-SL	56.703.8653.0	50
WKIF 2,5 N-D-SL	56.703.9453.0	50						
35 x 27 x 7,5 EN 60715	98.300.0000.0	1	35 x 27 x 7,5 EN 60715	98.300.0000.0	1	35 x 27 x 7,5 EN 60715	98.300.0000.0	1
35 x 24 x 15 EN 60715	98.360.0000.0	1	35 x 24 x 15 EN 60715	98.360.0000.0	1	35 x 24 x 15 EN 60715	98.360.0000.0	1
9708/2 S35	Z5.522.8553.0	100	9708/2 S35	Z5.522.8553.0	100	9708/2 S35	Z5.522.8553.0	100
WEF 1/35	Z5.523.9353.0	100	WEF 1/35	Z5.523.9353.0	100	WEF 1/35	Z5.523.9353.0	100
APIF 2,5	07.311.8353.0	10	APIF 2,5	07.311.8353.0	10	APIF 2,5 TM	07.312.8053.0	10
IVB WKF 2,5-2	Z7.280.6227.0	10	IVB WKF 2,5-2	Z7.280.6227.0	10	IVB WKF 2,5-2	Z7.280.6227.0	10
IVB WKF 2,5-3	Z7.280.6327.0	10	IVB WKF 2,5-3	Z7.280.6327.0	10	IVB WKF 2,5-3	Z7.280.6327.0	10
IVB WKF 2,5-4	Z7.280.6427.0	10	IVB WKF 2,5-4	Z7.280.6427.0	10	IVB WKF 2,5-4	Z7.280.6427.0	10
IVB WKF 2,5-5	Z7.280.6527.0	10	IVB WKF 2,5-5	Z7.280.6527.0	10	IVB WKF 2,5-5	Z7.280.6527.0	10
IVB WKF 2,5-6	Z7.280.6627.0	10	IVB WKF 2,5-6	Z7.280.6627.0	10	IVB WKF 2,5-6	Z7.280.6627.0	10
IVB WKF 2,5-7	Z7.280.6727.0	20	IVB WKF 2,5-7	Z7.280.6727.0	20	IVB WKF 2,5-7	Z7.280.6727.0	20
IVB WKF 2,5-8	Z7.280.6827.0	20	IVB WKF 2,5-8	Z7.280.6827.0	20	IVB WKF 2,5-8	Z7.280.6827.0	20
IVB WKF 2,5-9	Z7.280.6927.0	20	IVB WKF 2,5-9	Z7.280.6927.0	20	IVB WKF 2,5-9	Z7.280.6927.0	20
IVB WKF 2,5-10	Z7.280.7027.0	20	IVB WKF 2,5-10	Z7.280.7027.0	20	IVB WKF 2,5-10	Z7.280.7027.0	20
LEL 2,5/1 WEISS	05.561.6553.0	100	LEL 2,5/1 WEISS	05.561.6553.0	100	LEL 2,5/1 WEISS	05.561.6553.0	100
LEL 2,5/2 GRAU	05.561.6653.0	100	LEL 2,5/2 GRAU	05.561.6653.0	100	LEL 2,5/2 GRAU	05.561.6653.0	100
LEL 2,5/3 SCHWARZ	05.561.6753.0	100	LEL 2,5/3 SCHWARZ	05.561.6753.0	100	LEL 2,5/3 SCHWARZ	05.561.6753.0	100
ADF 2,5/4 GELB	04.343.6053.8	10	ADF 2,5/4 GELB	04.343.6053.8	10	ADF 2,5/4 GELB	04.343.6053.8	10
9813 M Sn	98.290.1000.0	1	9813 M Sn	98.290.1000.0	1	9813 M Sn	98.290.1000.0	1
WAK 16/2 BLAU	30.494.3021.6	100	WAK 16/2 BLAU	30.494.3021.6	100	WAK 16/2 BLAU	30.494.3021.6	100
WAK 35/2 BLAU	30.494.4021.6	100	WAK 35/2 BLAU	30.494.4021.6	100	WAK 35/2 BLAU	30.494.4021.6	100
WAK 35/2	30.494.4121.0	50	WAK 35/2	30.494.4121.0	50	WAK 35/2	30.494.4121.0	50
WKIF/SH/35	01.108.7653.0	10	WKIF/SH/35	01.108.7653.0	10	WKIF/SH/35	01.108.7653.0	10
WKIF SH/E/35	Z1.108.8453.0	100	WKIF SH/E/35	Z1.108.8453.0	100	WKIF SH/E/35	Z1.108.8453.0	100
DIN 5264 B 0,6 x 3,5	06.502.4000.0	5	DIN 5264 B 0,6 x 3,5	06.502.4000.0	5	DIN 5264 B 0,6 x 3,5	06.502.4000.0	5

## DIN rail terminal blocks for junction boxes with push-in spring connection, type *WKIS*



**Operating the installation block**

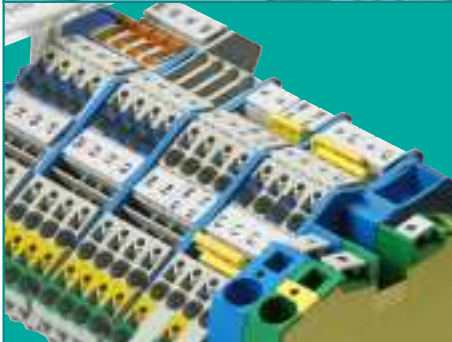

**Installation block WKIS 2,5...**



**Standard DIN rail terminal blocks for junction boxes**  
**WKF 2,5 – WKF 16**  
**WKF 2,5 – WKI 35**



The new installation blocks of the **fasis** BIT-S series with push-in spring extend the existing range and add value for the customer.

With **fasis** BIT-S the electrical installation can be made even more efficient. Rigid and flexible wires with ferrules can be connected directly without opening the termination point which can save much time.

The **fasis** BIT-S series has been designed for use in distribution systems. It accommodates the standardized dimensions for small and field distribution units with cover according to DIN 43871.

The neutral disconnect function integrated in **fasis** BIT-S enables the specified isolation measurement of all active conductors without having to disconnect the neutral conductor; the system can therefore be used in public and functional buildings.

### **Efficient connection and user-friendly circuit operation**

- Time savings and user-friendly operation with direct connection of rigid wires up to 4 mm<sup>2</sup> and flexible wires with ferrules up to 2.5 mm<sup>2</sup> without using any tools.
- Durably safe and dynamic connection due to the spring clamp connection with direct connection technology and isolation of the electrical and mechanical functions.
- Safety and user-friendliness even when disconnecting the neutral conductor from the busbar using a disconnect slide with position indicator.

### **Circuit wiring with only one terminal block**

- Clear wiring and assignment of the circuits due to 5 mm wide, three-tier design.
- Neutral conductor connection, line feed-through and ground connection are combined in one terminal block.
- Safe and user-friendly due to switchable neutral disconnect
  - Disconnect unit for the neutral busbar, version ...NT-D-SL
  - Internal disconnect of the neutral potential, version...NTM-D-SL

### **Power supply and distribution**

Standard DIN rail terminal blocks for junction boxes are available for supply, distribution and routing of power to the sub-distribution units.

- **fasis** BIT, DIN rail terminal blocks with tension spring up to 16 mm<sup>2</sup>
- **selos** BIT, DIN rail terminal blocks with screw connection up to 50 mm<sup>2</sup>

The ability to combine the installation blocks **fasis** BIT-S with standard DIN rail terminal blocks makes your applications flexible.

- Completely equipped with spring clamp technology
  - Circuit wiring using the efficient and compact **fasis** BIT-S installation blocks with direct connection technology
  - Supply and potential distribution in the likewise vibration-proof **fasis** BIT tension spring technology.
- Equipped with a combination of spring clamp and screw technology
  - Circuit wiring using the efficient and compact **fasis** BIT-S installation blocks with direct connection technology.
  - Supply and potential distribution using the universal and proven **selos** BIT screw technology.

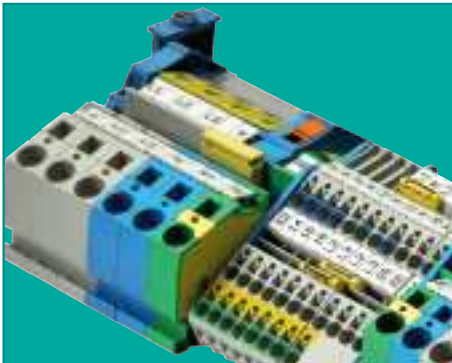

**Accumulating and isolating the neutral potential**

- Combining the neutral conductors of the individual circuits through the neutral busbar up to a current load of 140 A.
- Connection of the busbar’s neutral potential to the ground-fault circuit interrupter or supply for the distribution unit with connector clamp WAK in 16 or 35 mm<sup>2</sup>.
- Safe and stable 3D positioning of the neutral busbar through busbar support with end clamping function.

**Jumpering the terminal blocks**

- Touchproof jumpering with insulated cross connector.
- Flexible potential distribution with double jumpering channel and releasable links.
- High resistance of the cross connectors to the “rated current” of the rated cross section.
- High resistance to mechanical wear.
  - Due to a separation of the mechanical and electrical functions
  - Protection against excessive bending of the contact spring due to its structural design

**Marking live potentials**

- Marking of live components for greater safety.
- For terminal blocks that remain live when the main switch is disconnected (DIN VDE 0113).
- The snap-on cover can only be removed with a tool.

**Clearly marking all clamping points**

- Marking tags easily readable even with the wires connected.
- Clear assignment of wire to clamping point during wiring.
- Simplified troubleshooting for servicing.
- Individual marking with the **wiemarc** and **wieplot** marking systems.

**Selection of high-quality materials**

- Special alloys enable low contact resistance and provide a gas-tight contact area:
  - Clamping spring: stainless CrNi steel
  - Busbar: tin-plated copper
- Polyamide has excellent electrical, chemical and mechanical characteristics:
  - Temperature resistance: up to 120 °C
  - Creepage resistance: CTI 600
  - Flammability class: self-extinguishing, UL94-V0

# Multi-tier terminal blocks for junction boxes with push-in spring connection, type **WKIS**

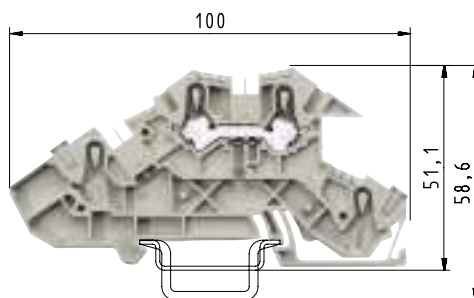

D – line feed-through, upper tier  
Only upper tier equipped.

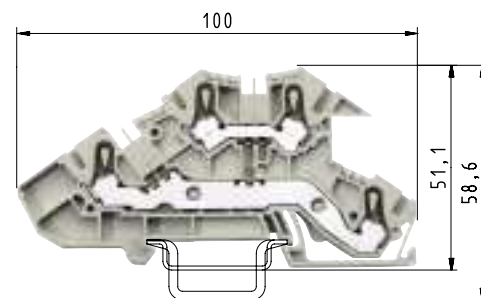

D – line feed-through  
D – line feed-through  
N – neutral feed-through

### WKIS 2,5 D

fine-stranded	solid	V	A
0.13 – 4 mm <sup>2</sup>	0.13 – 4 mm <sup>2</sup>	400 V/6 kV/3	24
	for 4 mm <sup>2</sup>		32

### WKIS 2,5 D-D WKIS 2,5 N-D

fine-stranded	solid	V	A
0.13 – 4 mm <sup>2</sup>	0.13 – 4 mm <sup>2</sup>	400 V/6 kV/3	24
	for 4 mm <sup>2</sup>		30
	for 4 mm <sup>2</sup> up to 3 blocks		32
5 mm			11 mm

EN 60947-7-1/DIN VDE 0611 T1

Width	Wire strip length	5 mm	11 mm
Approvals			

		Type	Part No.	Std. Pack	Type	Part No.	Std. Pack
Installation block	gray	WKIS 2,5 D	56.203.9653.0	50	WKIS 2,5 D-D	56.203.9753.0	50
Installation block	gray				WKIS 2,5 N-D	56.203.8953.0	50
Accessories							
1. Mounting rail 35, DIN rail 7.5 high	L = 2 m	35 x 27 x 7,5 EN 60715	98.300.0000.0	1	35 x 27 x 7,5 EN 60715	98.300.0000.0	1
Mounting rail 35, DIN rail 15 high	L = 2 m	35 x 24 x 15 EN 60715	98.360.0000.0	1	35 x 24 x 15 EN 60715	98.360.0000.0	1
2. End clamp TS 35, with screw	8 mm wide	9708/2 S35	Z5.522.8553.0	100	9708/2 S35	Z5.522.8553.0	100
End clamp TS 35, without screw	8 mm wide	WEF 1/35	Z5.523.9353.0	100	WEF 1/35	Z5.523.9353.0	100
3. End plate	gray, 1.5 mm wide	APIS 2,5	07.313.0253.0	10	APIS 2,5	07.313.0253.0	10
4. Partition	gray, 1.5 mm wide						
5. Cross connector, insulated							
	2 pole	IVB WKF 2,5-2	Z7.280.6227.0	10	IVB WKF 2,5-2	Z7.280.6227.0	10
	3 pole	IVB WKF 2,5-3	Z7.280.6327.0	10	IVB WKF 2,5-3	Z7.280.6327.0	10
	4 pole	IVB WKF 2,5-4	Z7.280.6427.0	10	IVB WKF 2,5-4	Z7.280.6427.0	10
	5 pole	IVB WKF 2,5-5	Z7.280.6527.0	10	IVB WKF 2,5-5	Z7.280.6527.0	10
	6 pole	IVB WKF 2,5-6	Z7.280.6627.0	10	IVB WKF 2,5-6	Z7.280.6627.0	10
	7 pole	IVB WKF 2,5-7	Z7.280.6727.0	20	IVB WKF 2,5-7	Z7.280.6727.0	20
	8 pole	IVB WKF 2,5-8	Z7.280.6827.0	20	IVB WKF 2,5-8	Z7.280.6827.0	20
	9 pole	IVB WKF 2,5-9	Z7.280.6927.0	20	IVB WKF 2,5-9	Z7.280.6927.0	20
	10 pole	IVB WKF 2,5-10	Z7.280.7027.0	20	IVB WKF 2,5-10	Z7.280.7027.0	20
Vertical jumper	1 pole	IVB WKF-V	Z7.261.1127.0	10	IVB WKF-V	Z7.261.1127.0	10
6. Notching tool compound plug			95.300.0500.0	1		95.300.0500.0	1
7. Wire entry guide							
	0.13 – 0.2 mm <sup>2</sup>	LELN 2,5/1 WEISS	05.564.3753.0	100	LELN 2,5/1 WEISS	05.564.3753.0	100
	0.25 – 0.5 mm <sup>2</sup>	LELN 2,5/2 GRAU	05.564.3853.0	100	LELN 2,5/2 GRAU	05.564.3853.0	100
	0.75 – 1.0 mm <sup>2</sup>	LELN 2,5/3 SCHWARZ	05.564.3953.0	100	LELN 2,5/3 SCHWARZ	05.564.3953.0	100
8. Cover with warning symbol over 4 blocks		ADF 2,5/4 GELB	04.343.6053.8	10	ADF 2,5/4 GELB	04.343.6053.8	10
9. Busbar, E-Cu 10x3 mm, tin-plated	L = 1 m	9813 M Sn	98.290.1000.0	1	9813 M Sn	98.290.1000.0	1
10. Connector clamp for busbar							
	16 mm <sup>2</sup> , 8.5 mm wide	WAK 16/2 BLAU	30.494.3021.6	100	WAK 16/2 BLAU	30.494.3021.6	100
	35 mm <sup>2</sup> , 12.5 mm wide	WAK 35/2 BLAU	30.494.4021.6	100	WAK 35/2 BLAU	30.494.4021.6	100
	35 mm <sup>2</sup> , 17 mm wide	WAK 35/2	30.494.4121.0	50	WAK 35/2	30.494.4121.0	50
11. Busbar support	2 mm wide	WKIF/SH/35	01.108.7653.0	10	WKIF/SH/35	01.108.7653.0	10
Busbar support, as end clamp	8 mm wide	WKIF SH/E/35	Z1.108.8453.0	100	WKIF SH/E/35	Z1.108.8453.0	100
12. Screwdriver, uninsulated							
	LONG, angled	DIN 5264 B 0,6 x 3,5 W	05.502.4100.0	10	DIN 5264 B 0,6 x 3,5 W	05.502.4100.0	10
	MINI, straight	DIN 5264 B 0,6 x 3,5 M	06.502.5000.0	10	DIN 5264 B 0,6 x 3,5 M	06.502.5000.0	10
	MINI, angled	DIN 5264 B 0,6 x 3,5 MW	05.502.4000.0	10	DIN 5264 B 0,6 x 3,5 MW	05.502.4000.0	10

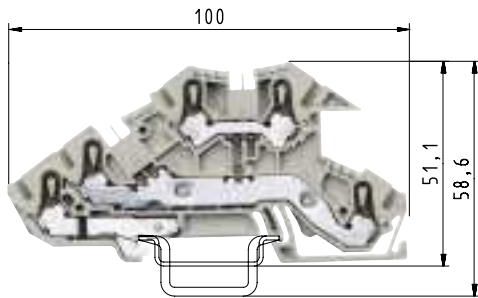

D – line feed-through  
N – neutral feed-through  
SL – ground

**WKIS 2,5 D-D-SL**  
**WKIS 2,5 N-D-SL**

fine-stranded solid V A  
0.13 – 4 mm<sup>2</sup> 0.13 – 4 mm<sup>2</sup> 250 V/400 V/4 kV/3 24  
for 4 mm<sup>2</sup> 30  
for 4 mm<sup>2</sup> up to 3 blocks 32  
5 mm 11 mm

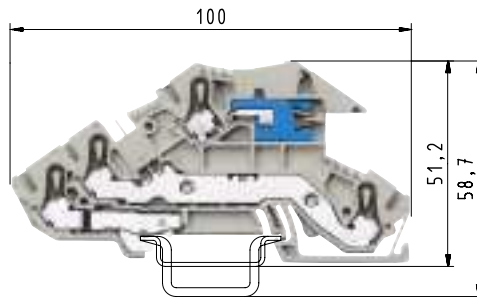

D – line feed-through  
NT – neutral feed-through, disconnectable  
SL – ground

**WKIS 2,5 NT-D-SL**

fine-stranded solid V A  
0.13 – 4 mm<sup>2</sup> 0.13 – 4 mm<sup>2</sup> 250 V/400 V/4 kV/3 22  
for 4 mm<sup>2</sup> 26  
5 mm 11 mm

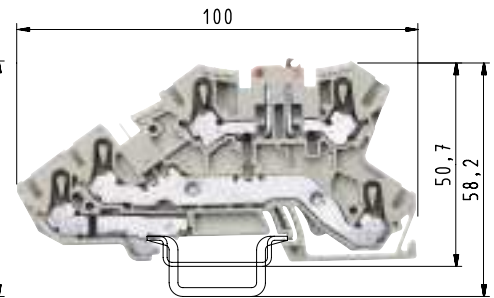

D – line feed-through  
NTM – neutral feed-through, knife edge disconnect  
SL – ground

**WKIS 2,5 NTM-D-SL**

fine-stranded solid V A  
0.13 – 4 mm<sup>2</sup> 0.13 – 4 mm<sup>2</sup> 250 V/400 V/4 kV/3 20  
for 4 mm<sup>2</sup> 24  
5 mm 11 mm

Type	Part No.	Std. Pack	Type	Part No.	Std. Pack	Type	Part No.	Std. Pack
WKIS 2,5 D-D-SL	56.203.9853.0	50	WKIS 2,5 NT-D-SL	56.203.9553.0	50	WKIS 2,5 NTM-D-SL	56.203.8653.0	50
WKIS 2,5 N-D-SL	56.203.9453.0	50						
35 x 27 x 7,5 EN 60715	98.300.0000.0	1	35 x 27 x 7,5 EN 60715	98.300.0000.0	1	35 x 27 x 7,5 EN 60715	98.300.0000.0	1
35 x 24 x 15 EN 60715	98.360.0000.0	1	35 x 24 x 15 EN 60715	98.360.0000.0	1	35 x 24 x 15 EN 60715	98.360.0000.0	1
9708/2 S35	Z5.522.8553.0	100	9708/2 S35	Z5.522.8553.0	100	9708/2 S35	Z5.522.8553.0	100
WEF 1/35	Z5.523.9353.0	100	WEF 1/35	Z5.523.9353.0	100	WEF 1/35	Z5.523.9353.0	100
APIS 2,5	07.313.0253.0	10	APIS 2,5	07.313.0253.0	10	APIS 2,5 TM	07.313.0353.0	10
IVB WKF 2,5-2	Z7.280.6227.0	10	IVB WKF 2,5-2	Z7.280.6227.0	10	IVB WKF 2,5-2	Z7.280.6227.0	10
IVB WKF 2,5-3	Z7.280.6327.0	10	IVB WKF 2,5-3	Z7.280.6327.0	10	IVB WKF 2,5-3	Z7.280.6327.0	10
IVB WKF 2,5-4	Z7.280.6427.0	10	IVB WKF 2,5-4	Z7.280.6427.0	10	IVB WKF 2,5-4	Z7.280.6427.0	10
IVB WKF 2,5-5	Z7.280.6527.0	10	IVB WKF 2,5-5	Z7.280.6527.0	10	IVB WKF 2,5-5	Z7.280.6527.0	10
IVB WKF 2,5-6	Z7.280.6627.0	10	IVB WKF 2,5-6	Z7.280.6627.0	10	IVB WKF 2,5-6	Z7.280.6627.0	10
IVB WKF 2,5-7	Z7.280.6727.0	20	IVB WKF 2,5-7	Z7.280.6727.0	20	IVB WKF 2,5-7	Z7.280.6727.0	20
IVB WKF 2,5-8	Z7.280.6827.0	20	IVB WKF 2,5-8	Z7.280.6827.0	20	IVB WKF 2,5-8	Z7.280.6827.0	20
IVB WKF 2,5-9	Z7.280.6927.0	20	IVB WKF 2,5-9	Z7.280.6927.0	20	IVB WKF 2,5-9	Z7.280.6927.0	20
IVB WKF 2,5-10	Z7.280.7027.0	20	IVB WKF 2,5-10	Z7.280.7027.0	20	IVB WKF 2,5-10	Z7.280.7027.0	20
IVB WKF-V	Z7.261.1127.0	10	IVB WKF-V	Z7.261.1127.0	10	IVB WKF-V	Z7.261.1127.0	10
	95.300.0500.0	1		95.300.0500.0	1		95.300.0500.0	1
LELN 2,5/1 WEISS	05.564.3753.0	100	LELN 2,5/1 WEISS	05.564.3753.0	100	LELN 2,5/1 WEISS	05.564.3753.0	100
LELN 2,5/2 GRAU	05.564.3853.0	100	LELN 2,5/2 GRAU	05.564.3853.0	100	LELN 2,5/2 GRAU	05.564.3853.0	100
LELN 2,5/3 SCHWARZ	05.564.3953.0	100	LELN 2,5/3 SCHWARZ	05.564.3953.0	100	LELN 2,5/3 SCHWARZ	05.564.3953.0	100
ADF 2,5/4 GELB	04.343.6053.8	10	ADF 2,5/4 GELB	04.343.6053.8	10	ADF 2,5/4 GELB	04.343.6053.8	10
9813 M Sn	98.290.1000.0	1	9813 M Sn	98.290.1000.0	1	9813 M Sn	98.290.1000.0	1
WAK 16/2 BLAU	30.494.3021.6	100	WAK 16/2 BLAU	30.494.3021.6	100	WAK 16/2 BLAU	30.494.3021.6	100
WAK 35/2 BLAU	30.494.4021.6	100	WAK 35/2 BLAU	30.494.4021.6	100	WAK 35/2 BLAU	30.494.4021.6	100
WAK 35/2	30.494.4121.0	50	WAK 35/2	30.494.4121.0	50	WAK 35/2	30.494.4121.0	50
WKIF/SH/35	01.108.7653.0	10	WKIF/SH/35	01.108.7653.0	10	WKIF/SH/35	01.108.7653.0	10
WKIF SH/E/35	Z1.108.8453.0	100	WKIF SH/E/35	Z1.108.8453.0	100	WKIF SH/E/35	Z1.108.8453.0	100
DIN 5264 B 0,6 x 3,5 W	05.502.4100.0	10	DIN 5264 B 0,6 x 3,5 W	05.502.4100.0	10	DIN 5264 B 0,6 x 3,5 W	05.502.4100.0	10
DIN 5264 B 0,6 x 3,5 M	06.502.5000.0	10	DIN 5264 B 0,6 x 3,5 M	06.502.5000.0	10	DIN 5264 B 0,6 x 3,5 M	06.502.5000.0	10
DIN 5264 B 0,6 x 3,5 MW	05.502.4000.0	10	DIN 5264 B 0,6 x 3,5 MW	05.502.4000.0	10	DIN 5264 B 0,6 x 3,5 MW	05.502.4000.0	10

## Accessories

### DIN rail terminal blocks for junction boxes



**Cross connector  
for feed-through blocks**



**Notching tool  
for cross connectors**



**Test plug**

for WKF, WKIF, WKIS 2,5 and WKF 4  
 solid fine-stranded V A  
 0.13 - 1.5 mm<sup>2</sup> 0.13 - 1.5 mm<sup>2</sup> 400 V 13,5  
 5 mm or 6 mm\* 8 mm

Type	Part No.	Std. Pack	Type	Part No.	Std. Pack	Type	Part No.	Std. Pack
<b>2.5 mm<sup>2</sup>, 5 mm wide</b>			<b>2.5 mm<sup>2</sup>, 5 mm wide</b>			<b>2.5 mm<sup>2</sup>, 5 mm wide</b>		
IVB WKF 2,5-2	Z7.280.6227.0	10	AKW /A	95.300.0500.0	1	Test plug PSWKC/F	Z1.299.9753.0	10
IVB WKF 2,5-3	Z7.280.6327.0	10				Blind piece	01.299.9753.0	10
IVB WKF 2,5-4	Z7.280.6427.0	10				End plate ZP/AP PS	07.312.6053.0	10
IVB WKF 2,5-5	Z7.280.6527.0	10						
IVB WKF 2,5-6	Z7.280.6627.0	10						
IVB WKF 2,5-7	Z7.280.6727.0	20						
IVB WKF 2,5-8	Z7.280.6827.0	20						
IVB WKF 2,5-9	Z7.280.6927.0	20						
IVB WKF 2,5-10	Z7.280.7027.0	20						
IVB WKF-V	Z7.261.1127.0	10						
<b>4 mm<sup>2</sup>, 6 mm wide</b>			<b>4 mm<sup>2</sup>, 6 mm wide</b>			<b>4 mm<sup>2</sup>, 6 mm wide</b>		
IVB WKF 4-2	Z7.261.1227.0	10	AKW /A	95.300.0500.0	1	Test plug PSWKC/F	Z1.299.9753.0	10
IVB WKF 4-3	Z7.261.1327.0	10				Blind piece	01.299.9753.0	10
IVB WKF 4-4	Z7.261.1427.0	10				End plate ZP/AP PS	07.312.6053.0	10
IVB WKF 4-5	Z7.261.1527.0	10						
IVB WKF 4-6	Z7.261.1627.0	10						
IVB WKF 4-7	Z7.261.1727.0	10						
IVB WKF 4-8	Z7.261.1827.0	10						
IVB WKF 4-9	Z7.261.1927.0	10						
IVB WKF 4-10	Z7.261.2027.0	10						
<b>6 mm<sup>2</sup>, 8 mm wide</b>			Notice!					
IVB WKF 6-2	Z7.282.4227.0	10	When using cross connectors notched out in terminal blocks of type WKF 2,5 and WKF 4 the rated voltages are reduced. Staggered plug-in of the jumpers is only possible for the terminal blocks of type WKIS.					
<b>10 mm<sup>2</sup>, 10 mm wide</b>								
IVB WKF 10-2	Z7.283.8227.0	10						
<b>16 mm<sup>2</sup>, 12 mm wide</b>								
IVB WKF 16-2	Z7.284.4227.0	10						



**Cover with warning symbol over 4 blocks**



**Wire entry guides**  
for wires with cross sections smaller than 1 mm<sup>2</sup>



**Screwdriver as operating tool**

Type	Part No.	Std. Pack	Type	Part No.	Std. Pack	Type	Part No.	Std. Pack
<b>2.5 mm<sup>2</sup>, 5 mm wide</b>			<b>2.5 mm<sup>2</sup>, 5 mm wide</b>			<b>2.5 mm<sup>2</sup>, 5 mm wide</b>		
ADFN 2,5/4 GELB	04.343.8353.8	10	LELN 2,5/1 WEISS	05.564.3753.0	100	Uninsulated, long and straight		
			for 0.13 - 0.2 mm <sup>2</sup> wires			DIN 5264 B 0,6x3,5	06.502.4000.0	10
			LELN 2,5/1 GRAU	05.564.3853.0	100	Uninsulated, short and straight		
			for 0.25 - 0.5 mm <sup>2</sup> wires			DIN 5264 B 0,6x3,5 M	06.502.5000.0	10
			LELN 2,5/1 SCHWARZ	05.564.3953.0	100	Uninsulated, long and angled		
			for 0.75 - 1.0 mm <sup>2</sup> wires			DIN 5264 B 0,6x3,5 W	05.502.4100.0	10
						Uninsulated, short and angled		
						DIN 5264 B 0,6x3,5 MW	05.502.4000.0	10
<b>4 mm<sup>2</sup>, 6 mm wide</b>			<b>4 mm<sup>2</sup>, 6 mm wide</b>			<b>4 mm<sup>2</sup>, 6 mm wide</b>		
ADF 4/4 GELB	04.343.6153.8	10	LEL 4/1 WEISS	05.561.8553.0	100	Uninsulated, long and straight		
			for 0,13 - 0,2 mm <sup>2</sup> wires			DIN 5264 B 0,6x3,5	06.502.4000.0	10
			LEL 4/2 GRAU	05.561.8653.0	100	Uninsulated, short and straight		
			for 0,25 - 0,5 mm <sup>2</sup> wires			DIN 5264 B 0,6x3,5 M	06.502.5000.0	10
			LEL 4/3 SCHWARZ	05.561.8753.0	100	Uninsulated, long and angled		
			for 0,75 - 1,0 mm <sup>2</sup> wires			DIN 5264 B 0,6x3,5 W	05.502.4100.0	10
						Uninsulated, short and angled		
						DIN 5264 B 0,6x3,5 MW	05.502.4000.0	10
<b>6 mm<sup>2</sup>, 8 mm wide</b>			<b>6 mm<sup>2</sup>, 8 mm wide</b>			<b>6 mm<sup>2</sup>, 8 mm wide</b>		
ADF 6/4 GELB	04.343.6253.8	10				DIN 5264 B 0,8x4	06.502.4100.0	5
<b>10 mm<sup>2</sup>, 10 mm wide</b>			<b>10 mm<sup>2</sup>, 10 mm wide</b>			<b>10 mm<sup>2</sup>, 10 mm wide</b>		
ADF 10/4 GELB	04.343.6453.8	10				DIN 5264 B 0,8x4	06.502.4100.0	5
<b>16 mm<sup>2</sup>, 12 mm wide</b>			<b>16 mm<sup>2</sup>, 12 mm wide</b>			<b>16 mm<sup>2</sup>, 12 mm wide</b>		
ADF 16/4 GELB	04.343.6653.8	10				DIN 5264 B 1x5,5	06.502.4200.0	5

## DIN rail terminal blocks for junction boxes with screw connection, type *WK/WKI*

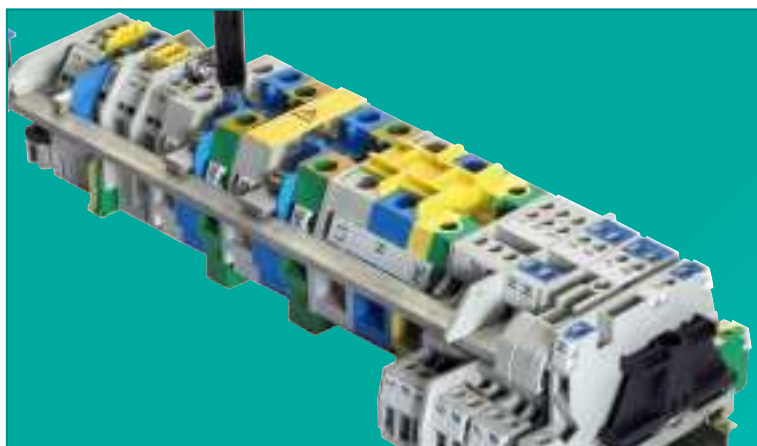

**Installation block  
WKI 4...**

**Standard  
DIN rail terminal  
blocks for junction  
boxes**

**Operation  
of the terminal blocks**

**Mixed  
and single-sort  
application**

The screw connection technology of series **selos** BIT is the best known and most widely used connection technology worldwide. The lateral connection technology is user-friendly both for supplying larger cross sections and for wiring the circuits. Thus, two conductors can be wired in one termination point, for example.

The **selos** BIT series has been designed for use in distribution systems. It accommodates the standardized dimensions for small and field distribution units with cover according to DIN 43871.

The neutral disconnect function integrated in **selos** BIT enables the specified isolation measurement of all active conductors without having to disconnect the neutral conductor; the system can therefore be used in public and functional buildings.

### **Circuit wiring with only one terminal block**

- Clear wiring and assignment of the circuits due to 6 mm<sup>2</sup> wide, three-tier design.
- Neutral conductor connection, line feed-through and ground connection are combined in one terminal block.
- Safe and user-friendly due to switchable neutral disconnect
  - Disconnect slide for the neutral busbar, version ...NT-D-SL
  - Internal disconnect of the neutral potential, version ...NTN-D-SL

### **Power supply and distribution**

- Incoming supply, power distribution in sub-systems and routing to other sub-systems.
- Tightening the clamping screw causes contact of the ground conductor to the mounting rail.
- PEN function is achieved using PEN blocks with the same contour.
- Safe disconnect of the neutral potential from the neutral busbar due to switchable neutral disconnect slide.

### **Convenient switching and operation**

- Operating safety thanks to worldwide proven screw connection. The funneled wire entries allow easy connection from the side even in crowded spaces.
- Gas-tight and dynamic connection thanks to screw connection technology in rising cage clamp system with one-piece threaded collar.
- User-friendly operation, even when the neutral conductor is disconnected from the neutral busbar, via disconnect unit.

### **Combinations within the system**

- A combination of the installation blocks with standard DIN rail terminal blocks and different connection styles.
- Example:
  - Consistent supply and circuit wiring with the proven **selos** BIT screw connection technology
  - Supply with **selos** BIT screw connection technology and circuit wiring with the compact installation blocks, for example with the **fasis** BIT-S direct connection technology.





### Busbar

#### Accumulating and isolating the neutral potential

- Combining the neutral conductors of the individual circuits through the neutral busbar up to a current load of 140 A.
- Connection of the busbar's neutral potential to the ground-fault circuit interrupter or supply for the distribution unit with connector clamp WAK in 16 or 35 mm<sup>2</sup>.
- Safe and stable 3D positioning of the neutral busbar through busbar support with end clamping function.



### Cross connectors

#### Jumpering the terminal blocks

- Choice between insulated and uninsulated cross connectors.
- Touch-proof insulated cross connectors according to IP 20 without additional actions.
- Uninsulated cross connectors require covers to make them touch-proof.
- Jumper bars as additional jumpering option are inserted into the clamping body together with the conductor.



### Cover

#### Marking live potentials

- Marking of live components for greater safety.
- For terminal blocks that remain live when the main switch is disconnected (DIN VDE 0113).
- The snap-on cover can only be removed with a tool.



### Partition plates

#### Potential isolation

- Rated voltage can be applied to adjacent uninsulated cross connectors.
- Can be mounted later on without loss due to separation
- The snap-on partition plate can only be removed with a tool.

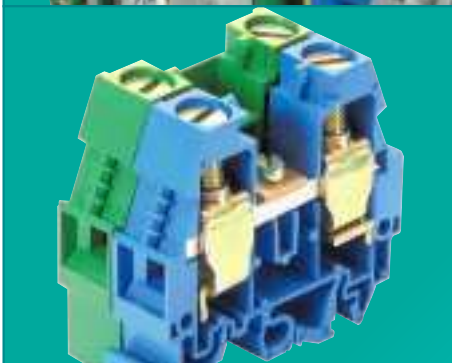

### Marking system

#### Clearly mark all clamping points

- Marking tags easily readable even with the wires connected.
- Clear assignment of wire to termination point on wiring.
- Simplified troubleshooting for maintenance.
- Individual marking with the **wiemarc** and **wieplot** marking system.

### Material

#### Selection of high-quality materials

- Special alloys enable low contact resistance and provide a gas-tight contact area:
  - Clamping spring: steel, zinc-plated and dichromated
  - Busbar: tin-plated copper
- Polyamide has excellent electrical, chemical and mechanical characteristics:
  - Temperature resistance: up to 120 °C
  - Creepage resistance: CTI 600
  - Flammability class: self-extinguishing, UL94-V0

**Multi-tier terminal blocks for junction boxes with screw connection, type *WKI***

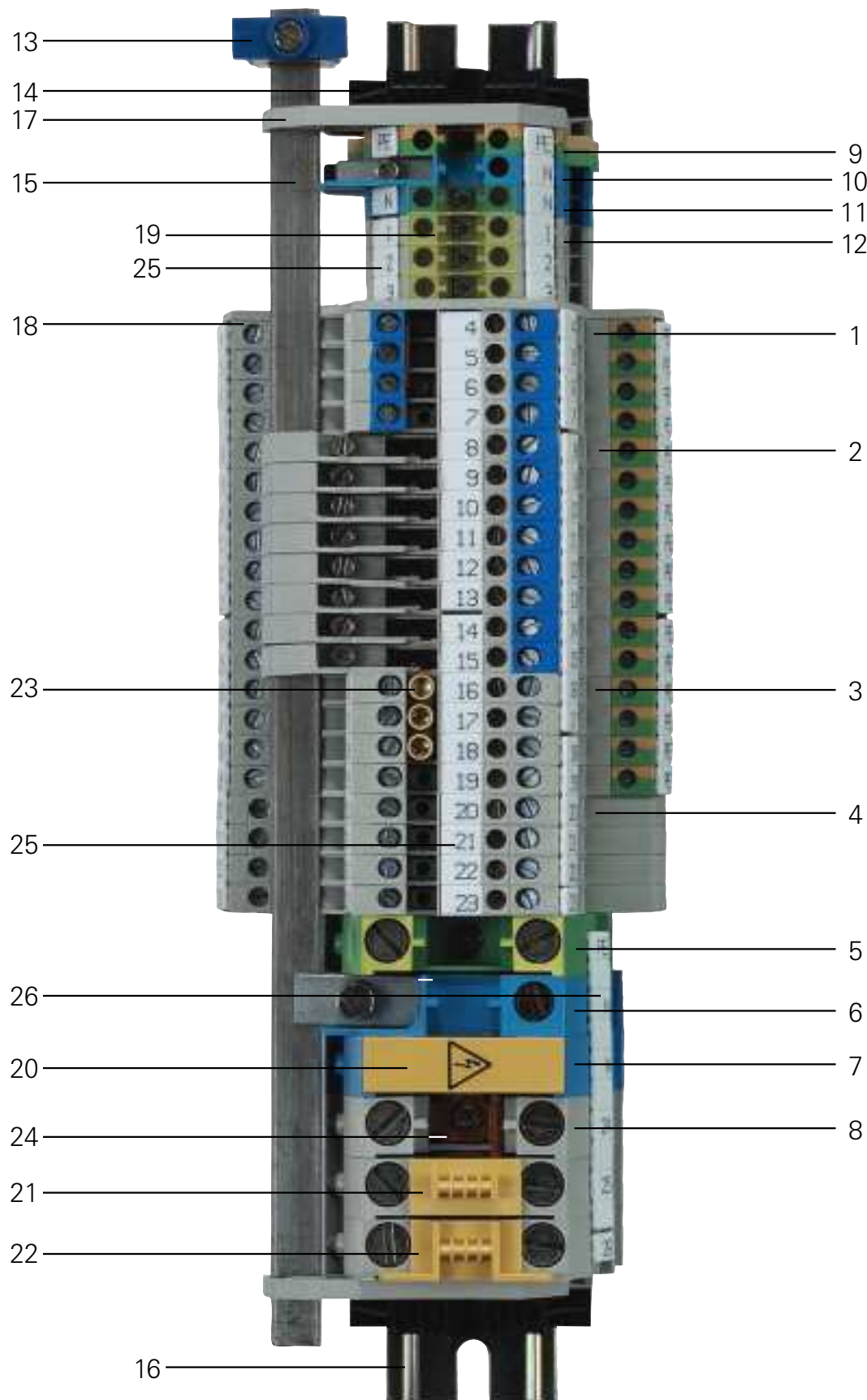

Item Description	Type	Part No.
1 Installation block	WKI 4 N-D-SL	56.404.9455.0
2 Installation block	WKI 4 NT-D-SL	56.404.9555.0
3 Installation block	WKI 4 D-D-SL	56.404.9855.0
4 Installation block	WKI 4 D-D	56.404.9755.0
5 Ground block	WKI 16 SL/35	56.516.9255.0
6 Neutral disconnect block	WKI 16 ETK/U	57.516.8255.0
7 Feed-through block	WKI 16 /U BLAU	57.516.1155.6
8 Feed-through block	WKI 16 /U	57.516.1155.0
9 Ground block	WK 4 SL/U	57.504.9055.0
10 Neutral disconnect block	WKN 4 ETK/U	57.504.8155.0
11 Feed-through block	WK 4 /U BLAU	57.504.0055.6
12 Feed-through block	WK 4 /U	57.504.0055.0
13 Connector clamp	WAK 16/2 BLAU	30.494.3021.6
14 End clamp	9708/2 S35	Z5.522.8553.0
15 Busbar 10x3	9813 M Sn	98.290.1000.0
16 Mounting rail	35x27x7,5	98.300.0000.0
17 Busbar support	WKI SH/U	01.108.3255.0
18 End plate	API 4/2	07.311.6555.0
19 Cover with warning symbol	AD 4/4 GELB	04.343.4856.8
20 Cover with warning symbol	ADI 16/1 GELB	04.325.8553.8
21 Cover with marking option	AD VB 16 GELB	04.326.2453.8
22 Partition plate with marking option	TS 16 GELB	07.311.2453.8
23 Cross connector, insulated (12 pole)	IVB WKI 4-12	Z7.271.5227.0
24 Cross connector, uninsulated	VB WKI 16-3	Z7.289.0327.0
25 Marking strip	9705 A/6/10 B	04.842.6053.0
26 Marking strip	9705 A/6/10/5 B	04.842.6553.0

# Feed-through blocks for junction boxes with screw connection, type *WKI*

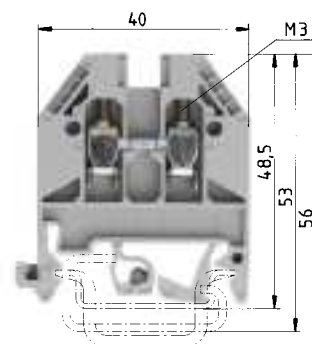
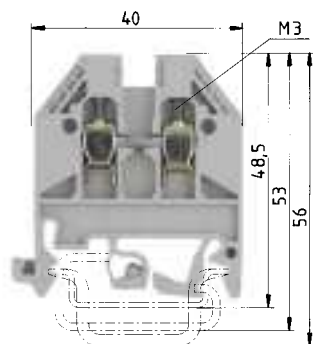

### WK 2,5/U

fine-stranded solid V A  
 0.5 – 2.5 mm<sup>2</sup> 0.5 – 4 mm<sup>2</sup> 800 V/8 kV/3 24  
 No. 22-12 AWG 600 V 20/30  
 No. 24-12 AWG 600 V 25  
 5 mm 9 mm



### WK 4/U

fine-stranded solid V A  
 0.5 – 4 mm<sup>2</sup> 0.5 – 6 mm<sup>2</sup> 800 V/8 kV/3 32  
 No. 22-10 AWG 600 V 30/35  
 No. 20-10 AWG 600 V 40  
 6 mm 9 mm



EN 60 947-7-1/DIN VDE 0611 T1  
 UL ratings field-factory wiring  
 CSA ratings  
 Width Wire strip length  
 Approvals

	Type	Part No.	Std. Pack	Type	Part No.	Std. Pack		
<b>Feed-through block</b>	gray	WK 2,5/U/V0	57.503.0055.0	100	WK 4/U/V0	57.504.0055.0	100	
<b>Feed-through block</b>	blue	WK 2,5/U BL/V0	57.503.0055.6	100	WK 4/U BL/V0	57.504.0055.6	100	
<b>Accessories</b>								
1. Mounting rail 35, DIN rail 7.5 high	L = 2 m	35 x 27 x 7,5 EN 60715	98.300.0000.0	1	35 x 27 x 7,5 EN 60715	98.300.0000.0	1	
Mounting rail 35, DIN rail 15 high	L = 2 m	35 x 27 x 15 EN 60715	98.360.0000.0	1	35 x 27 x 15 EN 60715	98.360.0000.0	1	
2. End clamp, TS 35, with screw	8 mm wide	9708/2 S35	Z5.522.8553.0	100	9708/2 S35	Z5.522.8553.0	100	
End clamp, TS 35, without screw	8 mm wide	WEF 1/35	Z5.523.9353.0	100	WEF 1/35	Z5.523.9353.0	100	
3. End plate	1.5 mm thick	gray	AP 2,5-4	07.311.0155.0	10	AP 2,5-4	07.311.0155.0	10
	1.5 mm thick	blue	AP 2,5-4 BLAU	07.311.0155.6	10	AP 2,5-4 BLAU	07.311.0155.6	10
	1.5 mm thick	green						
End plate	2 mm thick	gray						
	2 mm thick	blue						
	2 mm thick	green						
4. Partition	gray	TW 2,5-4	07.311.1155.0	10	TW 2,5-4	07.311.1155.0	10	
5. Cross connector with screws,	2 pole	IVB WK 2,5 - 2	Z7.280.2227.0	10	IVB WK 4-2	Z7.281.1227.0	10	
E-Cu, insulated	3 pole	IVB WK 2,5 - 3	Z7.280.2327.0	10	IVB WK 4-3	Z7.281.1327.0	10	
	4 pole	IVB WK 2,5 - 4	Z7.280.2427.0	10	IVB WK 4-4	Z7.281.1427.0	10	
	5 pole	IVB WK 2,5 - 5	Z7.280.2527.0	10	IVB WK 4-5	Z7.281.1527.0	10	
	6 pole	IVB WK 2,5 - 6	Z7.280.2627.0	10	IVB WK 4-6	Z7.281.1627.0	10	
6. Partition plate with marking option	yellow	TS 2,5 GELB	07.311.2053.8	10	TS 4 GELB	07.311.2153.8	10	
7. Cover with marking option	yellow	AD VB 2,5 GELB	04.326.2053.8	10	AD VB 4 GELB	04.326.2153.8	10	
8. Cover with warning symbol over 4 blocks	yellow	AD VB 5/4 GELB	04.343.4756.8	10	AD VB 6/4 GELB	04.343.4856.8	10	
Cover with warning symbol for 1 block	yellow							
9. Busbar								
E-Cu 10 x 3 mm, tin-plated, I <sub>N</sub> = 140	L = 1 m							
E-Cu 10 x 3 mm, blank, I <sub>N</sub> = 140 A	L = 1 m							
10. Connector clamp for busbar								
	16 mm <sup>2</sup>	8.5 mm wide						
	35 mm <sup>2</sup>	17 mm wide						
11. Busbar support	4 mm wide							
Busbar support	8 mm wide							
Marking accessories see page 52-55								

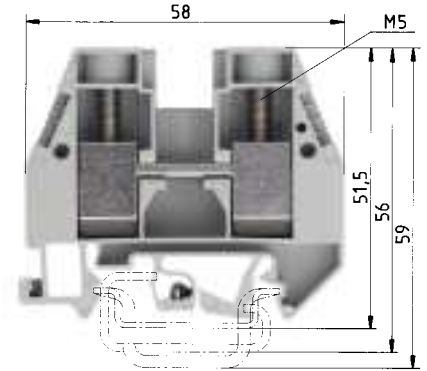
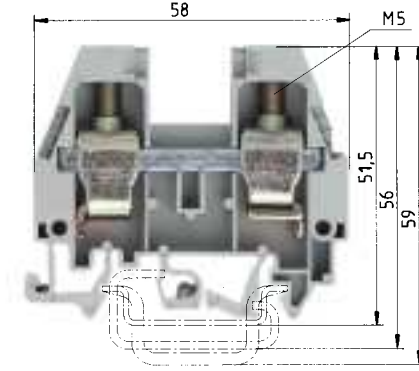
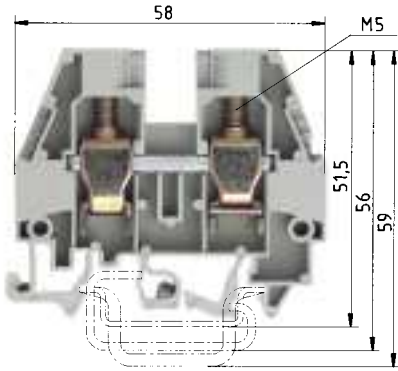

**WKI 10/U**

fine-stranded	solid/stranded	V	A
1–10 mm <sup>2</sup>	1.5–16 mm <sup>2</sup>	400 V/6 kV/3	57
No. 16-6 AWG		600 V	65/65
No. 16-6 AWG		600 V	70
10 mm			18 mm



**WKI 16/U**

fine-stranded	solid/stranded	V	A
1–16 mm <sup>2</sup>	1.5–25 mm <sup>2</sup>	400 V/6 kV/3	76
No. 12-4 AWG		600 V	65/90
No. 14-4 AWG		600 V	95
12 mm			16 mm



**WKI 35/U**

fine-stranded	stranded	V	A
6–35 mm <sup>2</sup>	6–50 mm <sup>2</sup>	400 V/6 kV/3	125
No. 10-2 AWG		600 V	95/95
No. 10-2 AWG		600 V	110
16 mm			13 mm



Type	Part No.	Std. Pack	Type	Part No.	Std. Pack	Type	Part No.	Std. Pack
WKI 10/U/V0	57.510.1155.0	50	WKI 16/U/V0	57.516.1155.0	50	WKI 35/U/V0	57.535.1155.0	20
WKI 10/U BL/V0	57.510.1155.6	50	WKI 16/U BL/V0	57.516.1155.6	50	WKI 35/U BL/V0	57.535.1155.6	20
35 x 27 x 7,5 EN 60715	98.300.0000.0	1	35 x 27 x 7,5 EN 60715	98.300.0000.0	1	35 x 27 x 7,5 EN 60715	98.300.0000.0	1
35 x 27 x 15 EN 60715	98.360.0000.0	1	35 x 27 x 15 EN 60715	98.360.0000.0	1	35 x 27 x 15 EN 60715	98.360.0000.0	1
9708/2 S35	Z5.522.8553.0	100	9708/2 S 35	Z5.522.8553.0	100	9708/2 S 35	Z5.522.8553.0	100
WEF 1/35	Z5.523.9353.0	100						
API 10-16	07.311.9455.0	10	API 10-16	07.311.9455.0	10	API 35	07.311.8855.0	10
API 10-16 BLAU	07.311.9455.6	10	API 10-16 BLAU	07.311.9455.6	10	API 35 BLAU	07.311.8855.6	10
IVB WKN 10-2	Z7.283.2227.0	10	IVB WKI 16-2	Z7.284.9227.0	10	IVB WKI 35-2	Z7.285.4227.0	5
IVB WKN 10-3	Z7.283.2327.0	10	IVB WKI 16-3	Z7.284.9327.0	10	IVB WKI 35-3	Z7.285.4327.0	5
IVB WKN 10-4	Z7.283.2427.0	10	IVB WKI 16-4	Z7.284.9427.0	10	IVB WKI 35-4	Z7.285.4427.0	5
IVB WKN 10-5	Z7.283.2527.0	10	IVB WKI 16-5	Z7.284.9527.0	10	IVB WKI 35-5	Z7.285.4527.0	5
IVB WKN 10-6	Z7.283.2627.0	10	IVB WKI 16-6	Z7.284.9627.0	10	IVB WKI 35-6	Z7.285.4627.0	5
TS 10 GELB	07.311.2353.8	10	TS 16 GELB	07.311.2453.8	10	TS 35 GELB	07.311.8653.8	10
AD VB 10 GELB	04.342.1056.8	10	AD VB 16 GELB	04.326.2453.8	10			
ADI 10/1 GELB	04.325.8553.8	10	ADI 16/1 GELB	04.325.8653.8	10	ADI 35/1 GELB	04.325.8753.8	10

# Neutral disconnect blocks for junction boxes with screw connection, type *WKI*

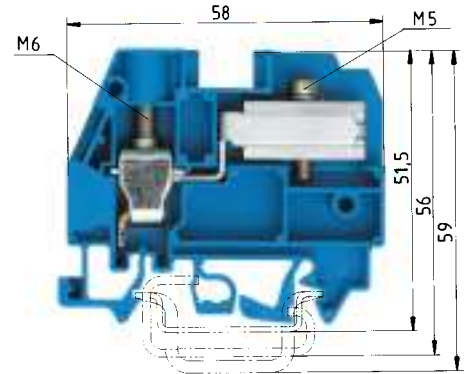
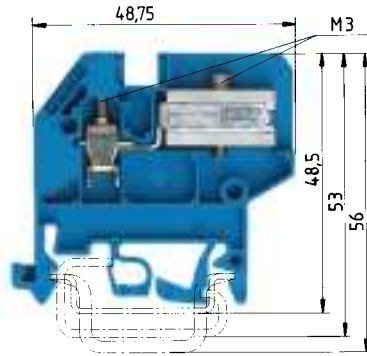

\*\*\*) for use in grounded networks

Current carrying capability:  
 fine-stranded: 4 mm<sup>2</sup> 25 A  
 solid: 6 mm<sup>2</sup> 30 A

Current carrying capability:  
 fine-stranded: 10 mm<sup>2</sup> 45 A  
 stranded: 16 mm<sup>2</sup> 50 A

### WKN 4 ETK/U

fine-stranded solid V A  
 0.5 – 4 mm<sup>2</sup> 0.5 – 6 mm<sup>2</sup> 400 V/6 kV/3\*\*)

### WKI 10 ETK/U

fine-stranded solid/stranded V A  
 1 – 10 mm<sup>2</sup> 1 – 16 mm<sup>2</sup> 400 V/6 kV/3\*\*)

EN 60 947-7-1/DIN VDE 0611 T1

U ratings

CSA ratings

Width

Approvals

Wire strip length

No. 20-10 AWG 600 V 25  
 6 mm 9 mm

No. 16-6 AWG 600 V 45  
 10 mm 13 mm



	Type	Part No.	Std. Pack	Type	Part No.	Std. Pack
<b>Neutral disconnect block</b> blue	WKN 4 ETK/U	57.504.8155.0	100	WKI 10 ETK/U	57.510.8255.0	50
<b>Connector clamp for Cu busbar</b> blue						
unplated						
<b>Accessories</b>						
1. Mounting rail 35, DIN rail 7.5 high L = 2 m	35 x 27 x 7,5 EN 60715	98.300.0000.0	1	35 x 27 x 7,5 EN 60715	98.300.0000.0	1
Mounting rail 35, DIN rail 15 high L = 2 m	35 x 27 x 15 EN 60715	98.360.0000.0	1	35 x 27 x 15 EN 60715	98.360.0000.0	1
2. End clamp, TS 35, with screw 8 mm wide	9708/2 S35	Z5.522.8553.0	100	9708/2 S35	Z5.522.8553.0	100
End clamp, TS 35, without screw 8 mm wide	WEF 1/35	Z5.523.9353.0	100	WEF 1/35	Z5.523.9353.0	100
3. End plate 1.5 mm thick gray						
1.5 mm thick blue	APN 4 ETK	07.311.1155.0	10	API 10-16 ETK/1	07.312.1955.0	10
1.5 mm thick green						
End plate 2 mm thick gray						
2 mm thick blue						
2 mm thick green						
4. Partition gray						
5. Cross connector with screws, 2 pole						
E-Cu, insulated 3 pole						
4 pole						
5 pole						
6 pole						
6. Partition plate with marking option yellow						
7. Cover with marking option yellow						
8. Cover with warning symbol over 4 blocks yellow						
Cover with warning symbol for 1 block yellow						
9. Busbar						
E-Cu 10 x 3 mm, blank, I <sub>N</sub> = 140 A L = 1 m	9813 M	98.290.0000.0	1	9813 M	98.290.0000.0	1
E-Cu 10 x 3 mm, tin-plated, I <sub>N</sub> = 140 A L = 1 m	9813 M SN	98.290.1000.0	1	9813 M SN	98.290.1000.0	1
10. Connector clamp for busbar						
16 mm <sup>2</sup> 8.5 mm wide	WAK 16/2 BLAU	30.494.3021.6	100	WAK 16/2 BLAU	30.494.3021.6	100
35 mm <sup>2</sup> 17 mm wide	WAK 35/2	30.494.4121.0	50	WAK 35/2	30.494.4121.0	50
11. Busbar support 4 mm wide	WKI SH/U	01.108.3255.0	10	WKI SH/U	01.108.3255.0	10
Busbar support 8 mm wide	WKIF SH/E/35	Z1.108.8453.0	100	WKIF SH/E/35	Z1.108.8453.0	100
Marking accessories see page 52-55						

# Connector clamp for Cu busbar (10x3 mm), type WAK

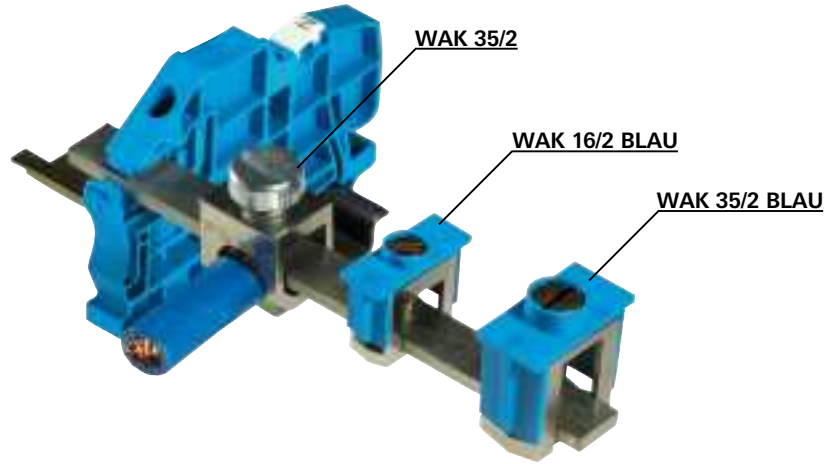
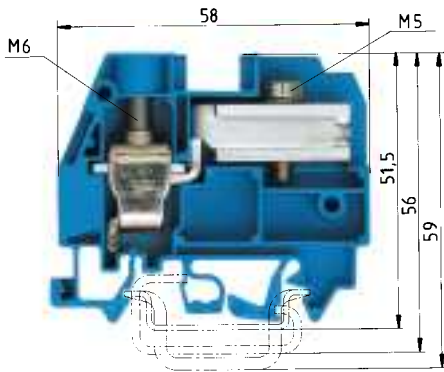

Current carrying capability:  
 fine-stranded: 16 mm<sup>2</sup> 62 A  
 stranded: 25 mm<sup>2</sup> 67 A

EN 60 998-2-1 CCA/CH

EN 60 998-2-1 CCA/CH

## WKI 16 ETK/U

fine-stranded solid/stranded V A  
 1 – 16 mm<sup>2</sup> 1 – 25 mm<sup>2</sup> 400 V/6 kV/3\*\*)

No. 14-4 AWG 600 V 65  
 12 mm 15 mm



## WAK 16/2

fine-stranded stranded V A  
 1.5 – 16 mm<sup>2</sup> 10 – 16 mm<sup>2</sup> 76

8,4 mm 16 mm



## WAK 35/2

fine-stranded stranded V A  
 16 – 35 mm<sup>2</sup> 16 – 35 mm<sup>2</sup> 125

17 mm 14 mm



Type	Part No.	Std. Pack	Type	Part No.	Std. Pack	Type	Part No.	Std. Pack
WKI 16 ETK/U/V0	57.516.8255.0	50	WAK 16/2 BLAU/V0	30.494.3021.6	100	WAK 35/2 BLAU	30.494.4021.0	50
						WAK 35/2	30.494.4121.0	50
35 x 27 x 7,5 EN 60715	98.300.0000.0	1						
35 x 27 x 15 EN 60715	98.360.0000.0	1						
9708/2 S35	Z5.522.8553.0	100						
API 10-16 ETK/1	07.312.1955.0	10						
9813 M	98.290.0000.0	1	9813 M	98.290.0000.0	1	9813 M	98.290.0000.0	1
9813 M SN	98.290.1000.0	1	9813 M SN	98.290.1000.0	1	9813 M SN	98.290.1000.0	1
WAK 16/2 BLAU	30.494.3021.6	100						
WAK 35/2	30.494.4121.0	50						
WKI SH/U	01.108.3255.0	10	WKI SH/U	01.108.3255.0	10	WKI SH/U	01.108.3255.0	10
WKIF SH/E/35	Z1.108.8453.0	100	WKIF SH/E/35	Z1.108.8453.0	100	WKIF SH/E/35	Z1.108.8453.0	100

# Ground blocks for junction boxes with screw connection, type *WKI SL*

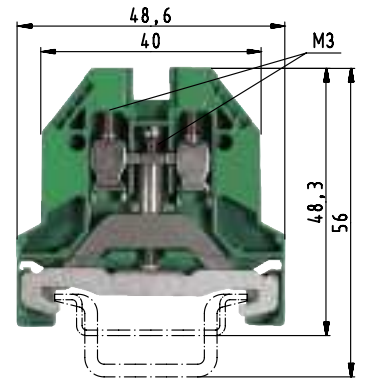
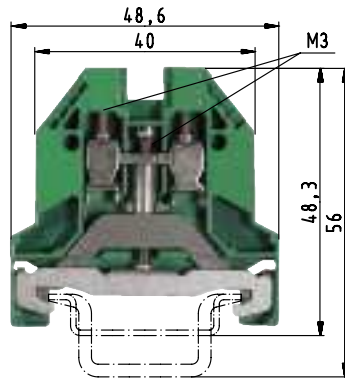

\*) Ratings to adjacent feed-through blocks of the same series and size

EN 60 947-7-2/DIN VDE 0611 T3  
 UL ratings  
 CSA ratings  
 Width  
 Approvals

Wire strip length

### WK 2,5 SL/35

fine-stranded solid V A  
 0.5 – 2.5 mm<sup>2</sup> 0.5 – 4 mm<sup>2</sup> 500 V/6 kV/3\*)  
 No. 22-12 AWG  
 No. 24-12 AWG  
 5 mm 9 mm

### WK 4 SL/35

fine-stranded solid V A  
 0.5 – 4 mm<sup>2</sup> 0.5 – 6 mm<sup>2</sup> 800 V/8 kV/3\*)  
 No. 22-10 AWG  
 No. 22-10 AWG  
 6 mm 9 mm

Ground block for TS 35		Type	Part No.	Std. Pack	Type	Part No.	Std. Pack
green/yellow		WK 2,5 SL/35	56.503.9055.0	100	WK 4 SL/35	56.504.9055.0	100
<b>Accessories</b>							
1. Mounting rail 35, DIN rail 7.5 high	L = 2 m	35 x 27 x 7,5 EN 60715	98.300.0000.0	1	35 x 27 x 7,5 EN 60715	98.300.0000.0	1
Mounting rail 35, DIN rail 15 high	L = 2 m	35 x 27 x 15 EN 60715	98.360.0000.0	1	35 x 27 x 15 EN 60715	98.360.0000.0	1
2. End clamp, TS 35, with screw	8 mm wide				9708/2 S35	Z5.522.8553.0	100
End clamp, TS 35, without screw	8 mm wide				WEF 1/35	Z5.523.9353.0	100
3. End plate	1.5 mm thick						
	1.5 mm thick						
	1.5 mm thick	AP 2,5-4 SL	07.311.7155.0	10	AP 2,5-4 SL	07.311.7155.0	10
End plate	2 mm thick						
	2 mm thick						
	2 mm thick						
4. Partition	gray						
5. Cross connector with screws,	2 pole						
E-Cu, insulated	3 pole						
	4 pole						
	5 pole						
	6 pole						
6. Partition plate with marking option	yellow						
7. Cover with marking option	yellow	AD VB 2,5 GELB	04.326.2053.8	10	AD VB4 GELB	04.326.2153.8	10
8. Cover with warning symbol over 4 blocks	yellow	AD VB 5/4 GELB	04.343.4756.8	10	AD VB 6/4 GELB	04.343.4856.8	10
Cover with warning symbol for 1 block	yellow						
9. Busbar							
E-Cu 10 x 3 mm, tin-plated, I <sub>N</sub> = 140 A	L = 1 m						
E-Cu 10 x 3 mm, blank, I <sub>N</sub> = 140 A	L = 1 m						
10. Connector clamp for busbar							
	16 mm <sup>2</sup> 8.5 mm wide						
	35 mm <sup>2</sup> 17 mm wide						
11. Busbar support	4 mm wide						
Busbar support	8 mm wide						
Marking accessories see page 52-55							



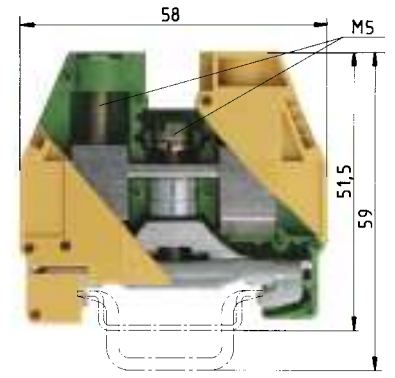
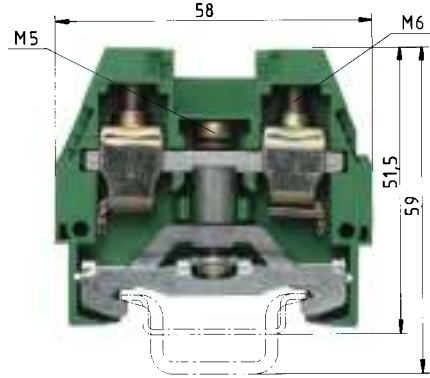
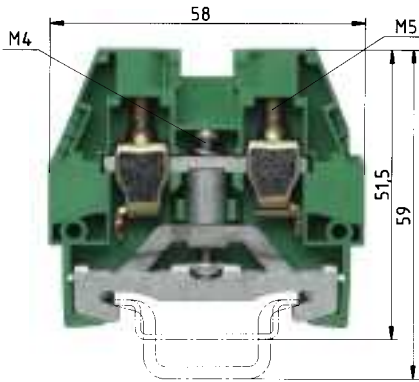

enclosed design

**WKI 10 SL/35**

fine-stranded solid/stranded V A  
 1 – 10 mm<sup>2</sup> 1.5 – 16 mm<sup>2</sup> 800 V/8 kV/3\*)  
 No. 16-6 AWG 600 V\*)  
 No. 16-6 AWG  
 10 mm 18 mm



**WKI 16 SL/35**

fine-stranded solid/stranded V A  
 1 – 16 mm<sup>2</sup> 1.5 – 25 mm<sup>2</sup> 400 V/6 kV/3\*)  
 No. 12-4 AWG 600 V\*)  
 12 mm 16 mm



**WKI 35 SL/35**

fine-stranded stranded V A  
 6 – 35 mm<sup>2</sup> 6 – 50 mm<sup>2</sup> 400 V/6 kV/3\*)  
 No. 10-2 AWG  
 16 mm 13 mm



Type	Part No.	Std. Pack	Type	Part No.	Std. Pack	Type	Part No.	Std. Pack
WKI 10 SL/35	56.510.9255.0	50	WKI 16 SL/35	56.516.9255.0	50	WKI 35 SL/35	56.535.9255.0	20
35 x 27 x 7,5 EN 60715	98.300.0000.0	1	35 x 27 x 7,5 EN 60715	98.300.0000.0	1	35 x 27 x 7,5 EN 60715	98.300.0000.0	1
35 x 27 x 15 EN 60715	98.360.0000.0	1	35 x 27 x 15 EN 60715	98.360.0000.0	1	35 x 27 x 15 EN 60715	98.360.0000.0	1
9708/2 S35	Z5.522.8553.0	100	9708/2 S35	Z5.522.8553.0	100	9708/2 S35	Z5.522.8553.0	100
WEF 1/35	Z5.523.9353.0	100						
API 10-16 SL	07.311.9555.0	10	API 10-16 SL	07.311.9555.0	10			
AD VB 10 GELB	04.326.2353.8	10	AD VB 16 GELB	04.326.2453.8	10	AD VB 10 GELB	04.326.2353.8	10
AD 10/1 GELB	04.325.8553.8	10	AD 16/1 GELB	04.325.8653.8	10	AD 35/1 GELB	04.325.8753.8	10

# PEN assembly block for junction boxes with screw connection, type *WKI*...

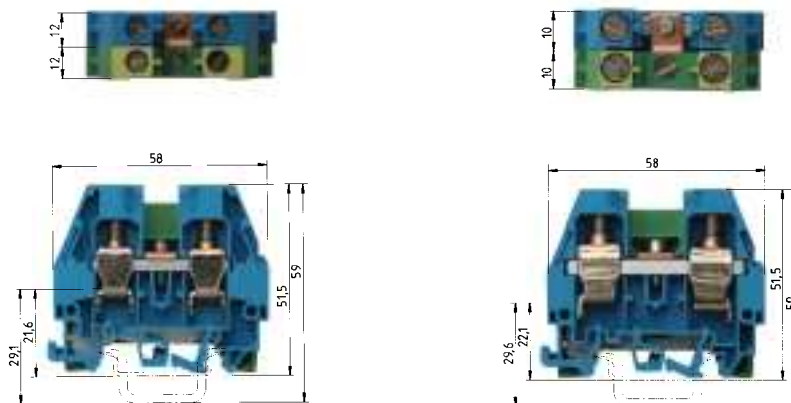

EN 60 947-7-1, EN 60 947-7-2

U ratings

CSA ratings

Width

Approvals

Wire strip length

## WKI 10 PEN/35

fine-stranded	solid/stranded	V	A
1 – 10 mm <sup>2</sup>	1.5 – 16 mm <sup>2</sup>	400 V/6 kV/3	57
No. 16-6 AWG		600 V	65/65
No. 16-6 AWG		600 V	70
20 mm			18 mm

## WKI 16 PEN/35

fine-stranded	solid/stranded	V	A
1 – 16 mm <sup>2</sup>	1.5 – 25 mm <sup>2</sup>	400 V/6 kV/3	76
No. 12-4 AWG		600 V	65/65
No. 14-4 AWG		600 V	95
24 mm			16 mm

PEN assembly block		Type	Part No.	Std. Pack	Type	Part No.	Std. Pack
green/yellow – blue		WKI 10 PEN/35/V0	56.510.9455.0	20	WKI 16 PEN/35/V0	56.516.9455.0	20
<b>Accessories</b>							
1. Mounting rail 35, DIN rail 7.5 high	L = 2 m	35 x 27 x 7,5 EN 60715	98.300.0000.0	1	35 x 27 x 7,5 EN 60715	98.300.0000.0	1
Mounting rail 35, DIN rail 15 high	L = 2 m	35 x 27 x 15 EN 60715	98.360.0000.0	1	35 x 27 x 15 EN 60715	98.360.0000.0	1
2. End clamp, TS 35, with screw	8 mm wide	9708/2 S35	Z5.522.8553.0	100	9708/2 S35	Z5.522.8553.0	100
End clamp, TS 35, without screw	8 mm wide	WEF 1/35	Z5.523.9353.0	100			
3. End plate	1.5 mm thick						
	1.5 mm thick						
	1.5 mm thick						
End plate	2 mm thick						
	2 mm thick						
	2 mm thick						
4. Partition							
5. Cross connector with screws,	2 pole						
E-Cu, insulated	3 pole						
	4 pole						
	5 pole						
	6 pole						
6. Partition plate with marking option	yellow	TS 10 GELB	07.311.2353.8	10	TS 16 GELB	07.311.2453.8	10
7. Cover with marking option	yellow	AD VB 10 GELB	04.326.2353.8	10	AD VB 16 GELB	04.326.2453.8	10
8. Cover with warning symbol over 4 blocks	yellow						
Cover with warning symbol for 1 block	yellow	ADI 10/1 GELB	04.325.8553.8	10	AD 16/1 GELB	04.325.8653.8	10
9. Busbar							
E-Cu 10 x 3 mm, tin-plated, I <sub>N</sub> = 140 A	L = 1 m						
E-Cu 10 x 3 mm, blank, I <sub>N</sub> = 140 A	L = 1 m						
10. Connector clamp for busbar							
	16 mm <sup>2</sup> 8.5 mm wide						
	35 mm <sup>2</sup> 17 mm wide						
11. Busbar support	4 mm wide						
Busbar support	8 mm wide						
Marking accessories see page 52-55							

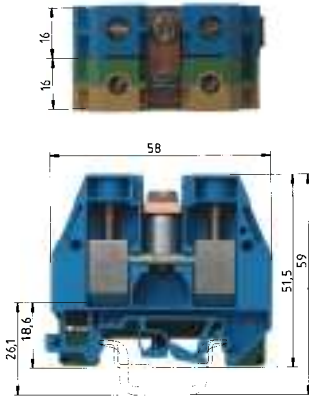

**WKI 35 PEN/35**

fine-stranded	stranded	V	A
6 – 35 mm <sup>2</sup>	6 – 50 mm <sup>2</sup>	400 V/6 kV/3	125
No. 10-2 AWG		600 V	95/95
No. 10-2 AWG		600 V	110
32 mm			13 mm

Type	Part No.	Std. Pack
WKI 35 PEN/35/V0	56.535.9455.0	10
35 x 27 x 7,5 EN 60715	98.300.0000.0	1
35 x 27 x 15 EN 60715	98.360.0000.0	1
9708/2 S35	Z5.522.8553.0	100
API 35 BLAU	07.311.8855.6	10
TS 35 GELB	07.311.8653.8	10
AD 35/1 GELB	04.325.8753.8	10

**PEN assembly block for junction box IEC 947-7-2 EN 60947-7-2**

Electrical power is often supplied to the plant in a 4 conductor three phase system (L1, L2, L3, and Ground). However, the electrical equipment in the plant may require a 5 conductor three phase system (L1, L2, L3, N, and Ground). Therefore, it is important to have a connection system to accommodate both possibilities.

The Wieland **WKI...PEN/35** system accomplishes this task. The PEN assembly terminal block consists of a ground terminal which is grounded to the DIN rail and a neutral terminal (color coded blue) which is electrically isolated from the DIN rail. The two terminals are commoned via a cross connector (jumper bar) thereby, tying the neutral terminal to ground.

When using the PEN assembly terminal block system, the DIN mounting rail only acts as a grounding bus. Therefore, copper mounting rail is not required and standard zinc plated steel DIN can be used for grounding purposes.

These assemblies have the same symmetry as the corresponding feed-through terminals of the WKI series and fit the height required for junction boxes per DIN 43871 when using DIN rail size 35 x 27 x 7.5.

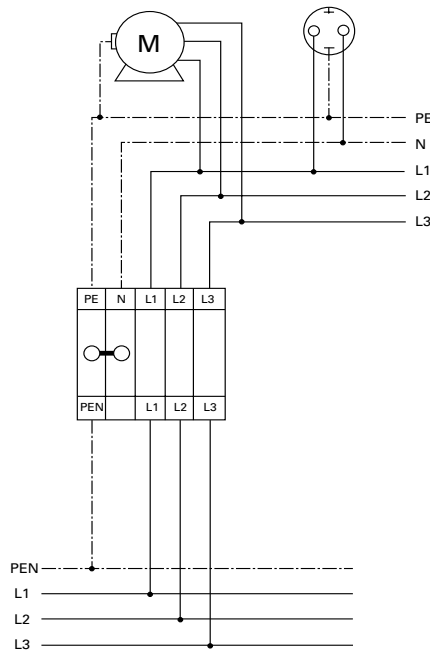

# Multi-tier terminal blocks for junction boxes with screw connection, type *WKI 4...*

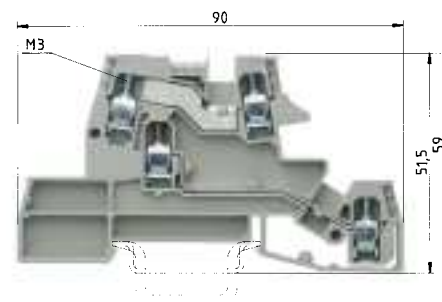
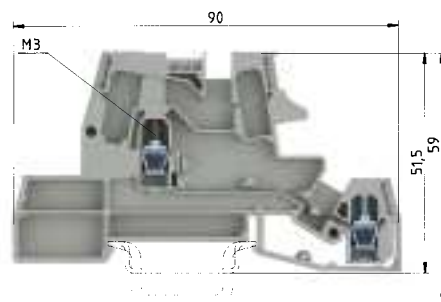

\*) For the current carrying capability of the mounting rail see **facts** & DATA

DU – line feed-through block  
Lower contact equipped only

D – line feed-through block  
D – line feed-through block

EN 60947-7-1/DIN VDE 0611 T1  
EN 60947-7-2  
U ratings  
CSA ratings  
Width  
Approvals

Wire strip length

### WKI 4 DU

fine-stranded solid		V	A
0.5 – 4 mm <sup>2</sup>	0.5 – 6 mm <sup>2</sup>	400 V/6 kV/3	26
No. 22-10 AWG		300 V	24
No. 22-10 AWG		300 V	25
6 mm			7 mm

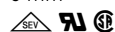

### WKI 4 D-D

fine-stranded solid		V	A
0.5 – 4 mm <sup>2</sup>	0.5 – 6 mm <sup>2</sup>	400 V/6 kV/3	26
No. 22-10 AWG		300 V	24
No. 22-10 AWG		300 V	25
6 mm			7 mm

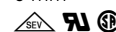

	Type	Part No.	Std. Pack	Type	Part No.	Std. Pack
<b>Installation block</b> gray				WKI 4 D-D	56.404.9755.0	50
<b>Lower tier of installation block equipped only</b>	WKI 4 DU	56.404.9655.0	50			
<b>Installation block with indicator lamp</b>						
<b>Accessories</b>						
1. Mounting rail 35, DIN rail 7.5 high L = 2 m	35 x 27 x 7,5 EN 60715	98.300.0000.0	1	35 x 27 x 7,5 EN 60715	98.300.0000.0	1
Mounting rail 35, DIN rail 15 high L = 2 m	35 x 24 x 15 EN 60715	98.360.0000.0	1	35 x 24 x 15 EN 60715	98.360.0000.0	1
2. End clamp TS 35, with screw 8 mm wide	9708/2 S35	Z5.522.8553.0	100	9708/2 S35	Z5.522.8553.0	100
End clamp, without screw 8 mm thick	WEF 1/35	Z5.523.9353.0	100	WEF 1/35	Z5.523.9353.0	100
3. End plate 2 mm thick	API 4/2	07.311.6555.0	10	API 4/2	07.311.6555.0	10
4. Partition	TWI 4	07.311.6955.0	10	TWI 4	07.311.6955.0	10
5. Cross connector with screws, E-Cu						
uninsulated 2 pole	9703/6-2	Z7.211.0227.0	50	9703/6-2	Z7.211.0227.0	50
up to 6 pole	9703/6-6	Z7.211.0627.0	50	9703/6-6	Z7.211.0627.0	50
insulated 12 pole	IVB WKI 4-12	Z7.271.5227.0	10	IVB WKI 4-12	Z7.271.5227.0	10
Field divisible strip – uninsulated, 70 pole	9703/6 M-70	Z7.211.0027.0	10	9703/6 M-70	Z7.211.0027.0	10
6. Busbar, E-Cu 10 x 3 mm, I <sub>N</sub> = 140 A L = 1 m	9813 M	98.290.0000.0	1	9813 M	98.290.0000.0	1
Busbar tin-plated, I <sub>N</sub> = 140 A L = 1 m	9813 M Sn	98.290.1000.0	1	9813 M Sn	98.290.1000.0	1
7. Busbar support 4 mm wide	WKI/SH/U	01.108.3255.0	10	WKI/SH/U	01.108.3255.0	10
Busbar support 8 mm wide	WKIF SH/E/35	Z1.108.8453.0	100	WKIF SH/E/35	Z1.108.8453.0	100
8. Connector clamp for busbar						
16 mm <sup>2</sup> 8.5 mm wide	WAK 16/2 BLAU	30.494.3021.6	100	WAK 16/2 BLAU	30.494.3021.6	100
35 mm <sup>2</sup> 17 mm wide	WAK 35/2	30.494.4121.0	50	WAK 35/2	30.494.4121.0	50
9. Screwdriver, uninsulated	DIN 5264 B 0,6 x 3,5	06.502.4000.0	5	DIN 5264 B 0,6 x 3,5	06.502.4000.0	5
Marking accessories see page 52-55						

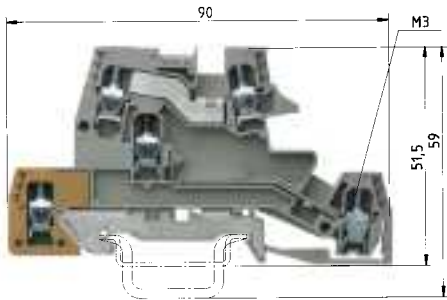

D – line feed-through block  
 D – line feed-through block  
 SL – ground

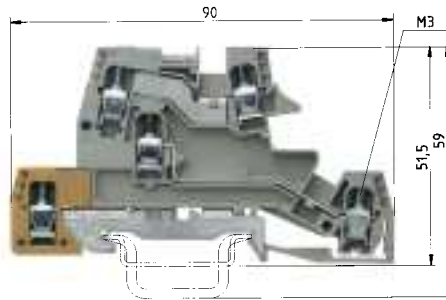

N – neutral feed-through block  
 D – line feed-through block  
 SL – ground

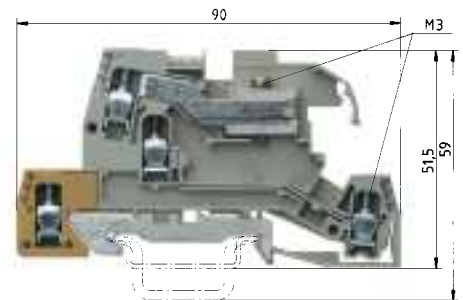

N – disconnect block  
 D – line feed-through block  
 SL – ground  
 GL – indicator lamp

**WKI 4 D-D-SL**

fine-stranded	solid	V	A
0.5 – 4 mm <sup>2</sup>	0.5 – 6 mm <sup>2</sup>	400 V/6 kV/3	26
No. 22-10 AWG		300 V	24
No. 22-10 AWG		300 V	25
6 mm			7 mm



**WKI 4 N-D-SL**

fine-stranded	solid	V	A
0.5 – 4 mm <sup>2</sup>	0.5 – 6 mm <sup>2</sup>	400 V/6 kV/3	26*)
No. 22-10 AWG		300 V	24
No. 22-10 AWG		300 V	25
6 mm			7 mm



**WKI 4 NT-D-SL (-GL)**

fine-stranded	solid	V	A
0.5 – 4 mm <sup>2</sup>	0.5 – 6 mm <sup>2</sup>	400 V/6 kV/3	26*)
No. 22-10 AWG		300 V	24
No. 22-10 AWG		300 V	25
6 mm			7 mm

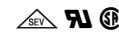

Type	Part No.	Std. Pack	Type	Part No.	Std. Pack	Type	Part No.	Std. Pack
WKI 4 D-D-SL	56.404.9855.0	50	WKI 4 N-D-SL	56.404.9455.0	50	WKI 4 NT-D-SL	56.404.9555.0	50
						WKI 4 NT-D-SL-GL	56.404.9255.0	50
35 x 27 x 7,5 EN 60715	98.300.0000.0	1	35 x 27 x 7,5 EN 60715	98.300.0000.0	1	35 x 27 x 7,5 EN 60715	98.300.0000.0	1
35 x 24 x 15 EN 60715	98.360.0000.0	1	35 x 24 x 15 EN 60715	98.360.0000.0	1	35 x 24 x 15 EN 60715	98.360.0000.0	1
9708/2 S35	Z5.522.8553.0	100	9708/2 S35	Z5.522.8553.0	100	9708/2 S35	Z5.522.8553.0	100
WEF 1/35	Z5.523.9353.0	100	WEF 1/35	Z5.523.9353.0	100	WEF 1/35	Z5.523.9353.0	100
API 4/2	07.311.6555.0	10	API 4/2	07.311.6555.0	10	API 4/2	07.311.6555.0	10
TWI 4	07.311.6955.0	10	TWI 4	07.311.6955.0	10	TWI 4	07.311.6955.0	10
9703/6-2	Z7.211.0227.0	50	9703/6-2	Z7.211.0227.0	50	9703/6-2	Z7.211.0227.0	50
9703/6-6	Z7.211.0627.0	50	9703/6-6	Z7.211.0627.0	50	9703/6-6	Z7.211.0627.0	50
IVB WKI 4-12	Z7.271.5227.0	10	IVB WKI 4-12	Z7.271.5227.0	10	IVB WKI 4-12	Z7.271.5227.0	10
9703/6 M-70	Z7.211.0027.0	10	9703/6 M-70	Z7.211.0027.0	10	9703/6 M-70	Z7.211.0027.0	10
9813 M	98.290.0000.0	1	9813 M	98.290.0000.0	1	9813 M	98.290.0000.0	1
9813 M Sn	98.290.1000.0	1	9813 M Sn	98.290.1000.0	1	9813 M Sn	98.290.1000.0	1
WKI/SH/U	01.108.3255.0	10	WKI/SH/U	01.108.3255.0	10	WKI/SH/U	01.108.3255.0	10
WKIF SH/E/35	Z1.108.8453.0	100	WKIF SH/E/35	Z1.108.8453.0	100	WKIF SH/E/35	Z1.108.8453.0	100
WAK 16/2 BLAU	30.494.3021.6	100	WAK 16/2 BLAU	30.494.3021.6	100	WAK 16/2 BLAU	30.494.3021.6	100
WAK 35/2	30.494.4121.0	50	WAK 35/2	30.494.4121.0	50	WAK 35/2	30.494.4121.0	50
DIN 5264 B 0,6 x 3,5	06.502.4000.0	5	DIN 5264 B 0,6 x 3,5	06.502.4000.0	5	DIN 5264 B 0,6 x 3,5	06.502.4000.0	5

# Multi-tier terminal blocks for junction boxes with screw connection, type *WKI 4...*

Nominal current according to VDE 0820 T2/EN 60 127-2 when using 1.6 W

- 6.3 A for single blocks
  - 4 A for blocks mounted directly adjacent to each other
- Voltage and current are determined by the LED and the fuse in the end application.

\*) For the current carrying capability of the mounting rail see **facts** & DATA

Busbar application:  
Position these terminals at the beginning or end of the assembly when incorporating the busbar system.

EN 60 947-7-1, EN 60 947-7-2

U ratings

CSA ratings

Width

Approvals

Wire strip length

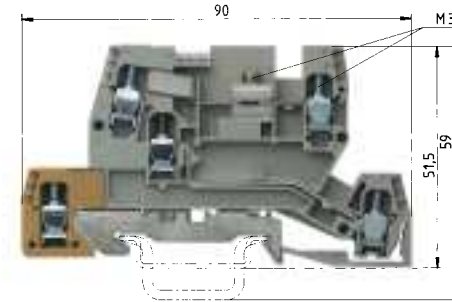

- NTN – disconnect block
- D – line feed-through block
- SL – ground

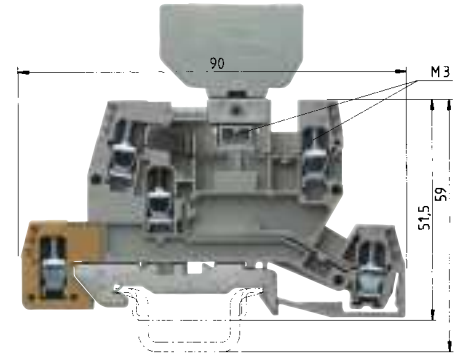

- TKG – fuse plug
- D – line feed-through block
- SL – ground block

### WKI 4 NTN-D-SL

fine-stranded	solid	V	A
0.5 – 4 mm <sup>2</sup>	0.5 – 6 mm <sup>2</sup>	400 V/6 kV/3	26*)
No. 22-10 AWG		300 V	24
No. 22-10 AWG		300 V	25
6 mm			7 mm



### WKI 4 TKG-D-SL

fine-stranded	solid	V	A
0.5 – 4 mm <sup>2</sup>	0.5 – 6 mm <sup>2</sup>	400 V/6 kV/3	26*)
No. 22-10 AWG		300 V	12
No. 22-10 AWG		300 V	25
6 mm			7 mm



		Type	Part No.	Std. Pack	Type	Part No.	Std. Pack
<b>Installation block</b>	gray	WKI 4 NTN-D-SL	56.404.9155.0	50	WKI 4 TKG-D-SL	56.404.8855.0	50
<b>Fuse holder</b> for 5 x 20 fuse	gray				Si ST	Z1.299.4055.0	10
<b>Fuse holder</b> with indicator (24 V)	gray				Si ST LED	Z1.299.4155.0	10
<b>Fuse holder</b> with indicator (220 V)	gray				Si ST GL	Z1.299.4255.0	10
(G fuse-links DIN 41571, 250 V/6.3 A, 5 x 20 mm)							
<b>Accessories</b>							
1. Mounting rail 35, DIN rail 7.5 high	L = 2 m	35 x 27 x 7,5 EN 60715	98.300.0000.0	1	35 x 27 x 7,5 EN 60715	98.300.0000.0	1
Mounting rail 35, DIN rail 15 high	L = 2 m	35 x 24 x 15 EN 60715	98.360.0000.0	1	35 x 24 x 15 EN 60715	98.360.0000.0	1
2. End clamp for TS 35, with screw	8 mm wide	9708/2 S35	Z5.522.8553.0	100	9708/2 S35	Z5.522.8553.0	100
Endclamp, without screw	8 mm thick	WEF 1/35	Z5.523.5753.0	100	WEF 1/35	Z5.523.9353.0	100
3. End plate	2 mm thick	API 4/3	07.311.6855.0	10	API 4/3	07.311.6855.0	10
4. Partition							
5. Corss connector with screws, E-Cu							
	uninsulated 2 pole	9703/6-2	Z7.211.0227.0	50	9703/6-2	Z7.211.0227.0	50
	up to 6 pole	9703/6-6	Z7.211.0627.0	50	9703/6-6	Z7.211.0627.0	50
	insulated 12 pole	IVB WKI 4-12	Z7.271.5227.0	10	IVB WKI 4-12	Z7.271.5227.0	10
	Field-divisible strip – max. number of poles	9703/6 M-70	Z7.211.0027.0	10	9703/6 M-70	Z7.211.0027.0	10
6. Busbar, E-Cu 10 x 3 mm, I <sub>N</sub> = 140 A	L = 1 m						
Busbar tin-plated, I <sub>N</sub> = 140 A	L = 1 m						
7. Busbar support	4 mm wide						
Busbar support	8 mm wide						
8. Connector clamp for busbar							
	16 mm <sup>2</sup> 8.5 mm wide						
	35 mm <sup>2</sup> 17 mm wide	DIN 5264 B 0,6 x 3,5	06.502.4000.0	5	DIN 5264 B 0,6 x 3,5	06.502.4000.0	5
9. Screwdriver, uninsulated							
Marking accessories see page 52-55							



## Accessories

### DIN rail terminal blocks for junction boxes

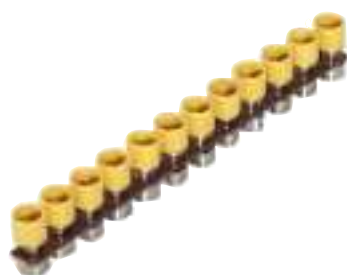

#### Cross connectors for installation blocks

#### Cross connectors for feed-through blocks

#### Insulated cross connectors for feed-through blocks

Type	Part No.	Std. Pack	Type	Part No.	Std. pack	Type	Part No.	Std. pack
for terminal blocks type			for terminal blocks type			for terminal blocks type		
<b>WKI 4 D-D</b>			<b>WK 4/U</b>			<b>WK 4/U</b>		
<b>WKI 4 DU</b>			2 pole VB WK 4-2 Z7.281.0227.0 10			2 pole IVB WK 4-2 Z7.281.1227.0 10		
<b>WKI 4 N-D-SL</b>			3 pole VB WK 4-3 Z7.281.0327.0 10			3 pole IVB WK 4-3 Z7.281.1327.0 10		
<b>WKI 4 NT-D-SL... (and variants)</b>			4 pole VB WK 4-4 Z7.281.0427.0 10			4 pole IVB WK 4-4 Z7.281.1427.0 10		
<b>WKI 4 NTN-D-SL</b>			5 pole VB WK 4-5 Z7.281.0527.0 10			5 pole IVB WK 4-5 Z7.281.1527.0 10		
<b>WKI 4 TKG-D-SL</b>			6 pole VB WK 4-6 Z7.281.0627.0 10			6 pole IVB WK 4-6 Z7.281.1627.0 10		
<b>WKI 4 D-D-SL</b>			70 pole VB WK 4 M-70 Z7.281.0027.0 10			7 pole IVB WK 4-7 Z7.281.1727.0 10		
<b>Cross connectors, uninsulated</b>			<b>WKI 10/U</b>			8 pole IVB WK 4-8 Z7.281.1827.0 10		
2 pole 9703/6-2	Z7.211.0227.0	50	2 pole VB WKI 10-2 Z7.288.0227.0 10			9 pole IVB WK 4-9 Z7.281.1927.0 10		
3 pole 9703/6-3	Z7.211.0327.0	50	3 pole VB WKI 10-3 Z7.288.0327.0 10			10 pole IVB WK 4-10 Z7.281.2027.0 10		
4 pole 9703/6-4	Z7.211.0427.0	50	4 pole VB WKI 10-4 Z7.288.0427.0 10			11 pole IVB WK 4-11 Z7.281.2127.0 10		
5 pole 9703/6-5	Z7.211.0527.0	50	5 pole VB WKI 10-5 Z7.288.0527.0 10			12 pole IVB WK 4-12 Z7.281.2227.0 10		
6 pole 9703/6-6	Z7.211.0627.0	50	6 pole VB WKI 10-6 Z7.288.0627.0 10			<b>WKI 10/U</b>		
70 pole 9703/6 M-70	Z7.211.0027.0	10	40 pole VB WKI 10 M-40 Z7.288.0027.0 10			2 pole IVB WKN 10-2 Z7.283.2227.0 10		
<b>Cross connectors, insulated</b>			<b>WKI 16/U</b>			3 pole IVB WKN 10-3 Z7.283.2327.0 10		
12 pole IVB WKI 4-12	Z7.271.5227.0	10	2 pole VB WKI 16-2 Z7.289.0227.0 10			4 pole IVB WKN 10-4 Z7.283.2427.0 10		
			3 pole VB WKI 16-3 Z7.289.0327.0 10			5 pole IVB WKN 10-5 Z7.283.2527.0 10		
			4 pole VB WKI 16-4 Z7.289.0427.0 10			6 pole IVB WKN 10-6 Z7.283.2627.0 10		
			5 pole VB WKI 16-5 Z7.289.0527.0 10			<b>WKI 16/U</b>		
			6 pole VB WKI 16-6 Z7.289.0627.0 10			2 pole IVB WKI 16-2 Z7.284.9227.0 10		
			20 pole VB WKI 16 M-20 Z7.289.0027.0 10			3 pole IVB WKI 16-3 Z7.284.9327.0 10		
						4 pole IVB WKI 16-4 Z7.284.9427.0 10		
						5 pole IVB WKI 16-5 Z7.284.9527.0 10		
						6 pole IVB WKI 16-6 Z7.284.9627.0 10		
						<b>WKI 35/U</b>		
						2 pole IVB WKI 35-2 Z7.285.4227.0 5		
						3 pole IVB WKI 35-3 Z7.285.4327.0 5		
						4 pole IVB WKI 35-4 Z7.285.4427.0 5		
						5 pole IVB WKI 35-5 Z7.285.4527.0 5		
						6 pole IVB WKI 35-6 Z7.285.4627.0 5		





**Jumper combs, insulated for installation blocks**

**Cover with warning symbol over 4 blocks  
Cover with warning symbol for 1 block**

**Partition plate with marking option  
Cover with marking option**

Type	Part No.	Std. pack	Type	Part No.	Std. Pack	Type	Part No.	Std. Pack
for terminal blocks type			for terminal blocks type			<b>Partition plate with marking option</b>		
						yellow		
<b>WKI 4 D-D</b>			<b>Cover with warning symbol over 4 blocks</b>			for terminal blocks type		
<b>WKI 4 DU</b>								
<b>WKI 4 N-D-SL</b>			<b>WK 4</b>			<b>WK 4/U</b>		
<b>WKI 4 NT-D-SL... (and variations)</b>			AD VB 6/4 GELB	04.343.4856.8	10	TS 4 GELB 07.311.2153.8	10	
<b>WKI 4 NTN-D-SL</b>								
<b>WKI 4 TGK-D-SL</b>						<b>WKI 10</b>		
<b>WKI 4 D-D-SL</b>			<b>Cover with warning symbol for 1 block</b>			TS 10 GELB07.311.2353.8	10	
0,5 mm thick, 6 mm spacing		yellow						
2 pole IVB 0,5 WK 4..-2	Z7.255.0227.0	10	<b>WKI 10</b>					
3 pole IVB 0,5 WK 4..-3	Z7.255.0327.0	10	ADI 10/1 GELB	04.325.8553.8	10	<b>WKI 16</b>		
4 pole IVB 0,5 WK 4..-4	Z7.255.0427.0	10				TS 16 GELB07.311.2453.8	10	
5 pole IVB 0,5 WK 4..-5	Z7.255.0527.0	10						
6 pole IVB 0,5 WK 4..-6	Z7.255.0627.0	10	<b>WKI 16</b>					
7 pole IVB 0,5 WK 4..-7	Z7.255.0727.0	10	ADI 16/1 GELB	04.325.8653.8	10	<b>WKI 35</b>		
8 pole IVB 0,5 WK 4..-8	Z7.255.0827.0	10				TS 35 GELB	07.311.8653.8	10
9 pole IVB 0,5 WK 4..-9	Z7.255.0927.0	10						
10 pole IVB 0,5 WK 4..-10	Z7.255.1027.0	10	<b>WKI 35</b>			<b>Cover with marking options</b>		
11 pole IVB 0,5 WK 4..-11	Z7.255.1127.0	10	ADI 35/1 GELB	04.325.8753.0	10	<b>for cross connector</b>	yellow	
12 pole IVB 0,5 WK 4..-12	Z7.255.1227.0	10				for terminal blocks type		
1 mm thick, 6 mm spacing		yellow				<b>WK 4</b>		
2 pole IVB 1 WK 4..-2	Z7.255.4227.0	10				AD VB 4 GELB	04.326.2153.8	10
3 pole IVB 1 WK 4..-3	Z7.255.4327.0	10						
4 pole IVB 1 WK 4..-4	Z7.255.4427.0	10				<b>WKI 10</b>		
5 pole IVB 1 WK 4..-5	Z7.255.4527.0	10				AD VB 10 GELB	04.326.2353.8	10
6 pole IVB 1 WK 4..-6	Z7.255.4627.0	10						
7 pole IVB 1 WK 4..-7	Z7.255.4727.0	10				<b>WKI 16</b>		
8 pole IVB 1 WK 4..-8	Z7.255.4827.0	10				AD VB 16 GELB	04.326.2453.8	10
9 pole IVB 1 WK 4..-9	Z7.255.4927.0	10						
10 pole IVB 1 WK 4..-10	Z7.255.5027.0	10						
11 pole IVB 1 WK 4..-11	Z7.255.5127.0	10						
12 pole IVB 1 WK 4..-12	Z7.255.5227.0	10						

## Accessories

### DIN rail terminal blocks for junction boxes

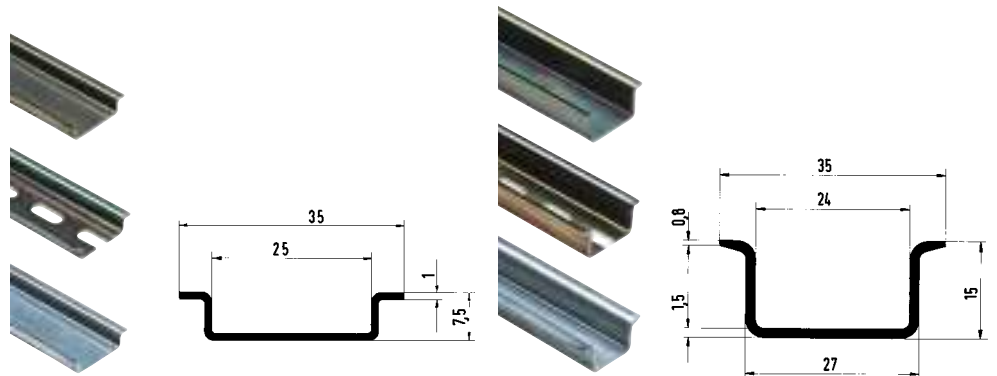

**Mounting rail 35 x 7.5**  
according to DIN EN 60715

**Mounting rail 35 x 15**  
according to DIN EN 60715

	Type	Part No.	Std. Pack	Type	Part No.	Std. Pack
<b>Mounting rail</b>						
1. Steel, galv. zinc-plated and dichromated, unslotted L = 2 m	35 x 27 x 7,5 EN 50022	98.300.0000.0	1	35 x 27 x 15 EN 50022	98.370.0000.0	1
Steel, galv. zinc-plated and dichromated, slotted L = 2 m	35 x 27 x 7,5 EN 50022 gelocht	98.300.1000.0	1	35 x 27 x 15 EN 50022	98.370.1000.0	1
2. Steel, unplated unslotted L = 2 m	35 x 27 x 7,5 EN 50022 blank	98.300.0010.0	1			
Steel, unplated slotted L = 2 m						
3. Steel, hot-galvanized unslotted L = 2 m						
Steel, hot-galvanized slotted L = 2 m						
4. E copper unslotted L = 2 m						
E copper slotted L = 2 m						
<b>End clamp</b>						
5. End clamp, TS 35, with screw 8 mm wide						
6. End clamp, TS 35, with screw 8/17.5 mm wide with marking facility for block assemblies						
7. End clamp, TS 35, without screw 8 mm wide						
8. End clamp, TS 35, without screw 8/17.5 mm wide with marking facility for block assemblies						
9. Busbar support, without screw 8 mm wide						
Busbar support, tag included 8 mm						
10. Clamping screw for busbar support						
11. Marking tag with carrier						
12. Marking card in perforated sheets (1 sheet = 100 single tags)						

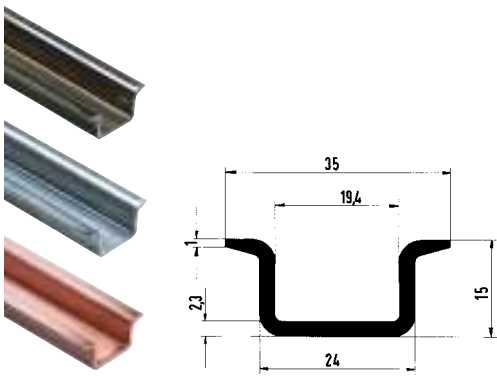

**Mounting rail 35 x 15**  
according to DIN EN 60715

**End clamp for TS 35**  
screw mount

**End clamp for TS 35**  
screwless mount

Type	Part No.	Std. Pack	Type	Part No.	Std. Pack	Type	Part No.	Std. Pack
35 x 27 x 15 EN 50022	98.360.0000.0	1						
35 x 27 x 15 EN 50022 ZN	98.360.0004.0	1						
35 x 27 x 15 EN 50022 CU	98.380.0000.0	1						
			9708/2 S/35	Z5.522.8553.0	100			
			9708/2 BS/35	69.920.0553.0	100			
						WEF 1/35	Z5.523.9353.0	100
						WEF 1 BS/35	69.920.1053.0	100
						WKIF SH/E/35*	Z1.108.8453.0	100
							69.920.1153.0	100
							05.091.0212.0	100
						BS/R	Z4.243.8453.0	10
				04.019.0289.0	10		04.019.0289.0	10

\* Spacing between WKIF SH and WKIF SH max. 200 mm

## Configuration system and marking accessories for DIN rail terminal blocks



### Configuration software **wieplan**

### Marking computer **marcom 2**

### Marking software **wiemarc**

Type	Part No.	Std. Pack	Type	Part No.	Std. Pack	Type	Part No.	Std. Pack
wieplan CD	95.502.1000.0	1	marcom 2	95.502.0000.0	1	wiemarc CD	95.502.0501.0	1
<b>Contents:</b>			<b>Contents:</b>			<b>Contents:</b>		
CD with cover			Marking computer in case			CD with cover		
			European power supply unit					
			Power Pack					
			Data cassette with job memory					
			Marking tag carrier					
			Plotter pen, 0.25 mm					
			Cleaning set					
<b>Description:</b>			<b>Description:</b>			<b>Description</b>		
<b>wieplan</b> is a software used to configure, document and order DIN rail terminal block assemblies. The intuitive user interface makes working with <b>wieplan</b> as easy as child's play.			<b>wieland marcom 2</b> is a freely programmable marking computer for DIN rail terminal blocks, pluggable connectors, switching devices and cables. The computer provides of a large number of fonts, with numerical and alphanumerical characters and symbols.			<b>wiemarc</b> is a Windows® based plotter software for customized marking using the <b>wieplot</b> 500 plotter system.		
<b>wieplan</b> enables data exchange through CAE systems:			<b>marcom 2</b> is portable and can be used at any location; it can be operated either using the mains or batteries.			Both the Wieland standard marking system and marking tags and labels of other suppliers can be marked easily. The <b>wiemarc</b> software version 4.0 provides the option of connecting to the		
– EPLAN 5						<b>wieplot</b> 500 E-UNIT engraving system.		
– EPLAN Electric P8								
<b>System requirements:</b>			<b>Technical data:</b>			<b>System requirements:</b>		
Pentium II PC or compatible, min. 200 MHz			Operator panel: 190 mm x 45 mm			Pentium II PC or compatible, min. 200 MHz		
64 Mbyte RAM			Resolution: 0.01 mm			64 Mbyte RAM		
CD-ROM drive			Power supply unit: 50/60 Hz, 100 - 230 V			CD-ROM drive		
VGA graphics adapter and monitor			Output voltage: 9.5 V (150 mV/1.4 VA)			VGA graphics adapter and monitor		
			14 V (450 mA/6.3 VA)					
<b>wieplan</b> supports: Windows 98®			Replaceable battery: 16.8 V (14 NiCd cells)			<b>wieplan</b> supports: Windows 98®		
Windows 2000®			Dimensions: 380 mm x 190 mm x 63 mm			Windows 2000®		
Windows NT®			Weight: 6.2 kg			Windows NT®		
Windows ME®						Windows ME®		
Windows XP®						Windows XP®		



**Plotter system *wieplot* 500**

**Accessories for *wieplot* 500**

**Engraving unit for *wieplot* 500**

Type	Part No.	Std. Pack	Type	Part No.	Std. Pack	Type	Part No.	Std. Pack
Complete package			Accessories kit	95.502.0610.0	1	wieplot 500 E-UNIT	95.502.0700.0	1
wieplot 500	95.502.0604.0	1						
<b>Contents:</b>			<b>Contents:</b>			<b>Contents:</b>		
Plotter <i>wieplot</i> 500			Plotter pen 0.25 mm with ink cartridge			Engraving spindle		
Data cable and manual			Permanent plotter pen 0.3 mm			Engraving head (with fuse and counter bearing)		
4 receptacles for WSB*			Cleaning set			Control unit <i>wieplot</i> VEC 500		
Accessories kit						Vacuum cleaner <i>wieplot</i> VC 500		
Software <i>wiemarc</i>			<b>Plotter pens for <i>wieplot</i> 500 systems:</b>			Connection cables		
			Plotter pen 0.18 mm	95.502.0118.0				
			Plotter pen 0.25 mm	95.502.0125.0				
			Plotter pen 0.35 mm	95.502.0135.0				
			Plotter pen 0.50 mm	95.502.0150.0				
<b>Description</b>			Plotter pen 0.70 mm	95.502.0170.0		<b>Description:</b>		
With <i>wiemarc</i> you can create customized marking data on your PC. These can then be output on the <i>wieplot</i> 500 plotter system to various marking plates.			Plotter pen 1.00 mm	95.502.0100.0		The <i>wieplot</i> 500 E-UNIT engraving unit has been designed for use with the <i>wieplot</i> 500 plotter. The system is set up for engraving multi-layer plastic tags.		
			Perm. plotter pen 0.30 mm	95.502.0230.0		The Plotboard A4 in a 297 x 202 mm format is the receptacle for marking paper sheets and labels and also enables engraving of plastic boards.		
* WSB (= Wieland standard marking system)			Perm. plotter pen 0.70mm	95.502.0270.0				
			Dispos. plotter pen 0.25 mm	95.502.0125.1				
			Dispos. plotter pen 0.35 mm	95.502.0135.1				
			Hand pens 0.25 mm	95.502.0425.0				
			Hand pens 0.35 mm	95.502.0435.0				
			Hand pens 0.50 mm	95.502.0450.0				
			Hand pens 0.70 mm	95.502.0470.0				
<b>Technical data:</b>			<b>Accessories:</b>			<b>Accessories:</b>		
Resolution: 0.01 mm			Ink cartridge P1.0, 5 x 1 ml	95.502.0199.0		Graving tool SET, complete	95.502.0710.0	
Accuracy: +/- 0.05 mm			Cleaning set	95.502.0198.0		Graving tool 0.2 mm	95.502.0710.2	
Power supply unit: 50/60 Hz, 100 – 240 V,			Pen cleaner	95.502.0197.0		Graving tool 0.3 mm	95.502.0710.3	
Output voltage: 24 V DC 1.4 A			Dust protection hood	95.502.0612.0		Graving tool 0.4 mm	95.502.0710.4	
Current input: approx. 0.3 A at 220 V			Service kit for pen station	95.502.0613.0		Graving tool 0.5 mm	95.502.0710.5	
Approval: UL-UL1950			Seal inserts kit			Graving tool 0.7 mm	95.502.0710.7	
						Graving tool 1.0 mm	95.502.0711.0	
			<b>Receptacles for Wieland marking plates</b>			<b>Receptacle:</b>		
Radio interf. suppr.: FCC class B			Receptacle for WSB	95.502.0620.0		Plotboard A4	95.502.0625.0	
Dimensions: 660 mm x 440 mm x 125 mm								
Weight: 8 kg			Available on request:					
Interfaces: USB level 1.1, parallel			Receptacles for marking systems from competition					
			Use of <i>wiemarc</i> with non-Wieland plotter systems					

## Marking accessories

### DIN rail terminal blocks for junction boxes



Material:  
Polyamide 6.6  
black figures on white background

DIN rail terminal blocks, type WKF, can accept marking tags on both sides on top of the block in a 3-chamber slot. It can be either 3 single number tags from the tear-off marking strip, or single tags, or marking strips.

- 1. Marking strips** marked and unmarked made from Polyamide 6.6, suitable for 10 terminal blocks. Marking 1-10, 11-20 etc. up to 991-999.
  - Type 9705 A/5/10 (5 mm spacing) for DIN rail terminal blocks type WK/WKIF/WKIS 2,5...
  - Type 9705 A/6/10 (6 mm spacing) for DIN rail terminal blocks type WK/WKI/WKF 4...
  - Type 9705 A/5/10/5 B (10 mm spacing) for DIN rail terminal blocks type WKI/WKF 10...
  - Type 9705 A/6/10/5 B (12 mm spacing) for DIN rail terminal blocks type WKI/WKIF 16...
  - Type 9705 A/8/10/5 B (16 mm spacing) for DIN rail terminal blocks type WKI 35...
- 2. Tear-off marking strips** with 10 marking tags made from Polyamide 6.6, white, marked and unmarked.
 

This marking system considerably reduces the time required for marking terminal block assemblies. For numerical of terminal block rows only 11 stock positions are required. As the time used for picking and attaching the tags is reduced, and as stockkeeping is low and the prices extremely favorable, attractive cost savings are the result from using these tear-off marking strips.

Type 9704 A...
- 3. Single marking tag** made from Polyamide 6.6, white, marked and unmarked. Type 9705 A...
  - | Type                           | Part No.      | Std. Pack          | Type                                | Part No.      | Std. Pack |
|--------------------------------|---------------|--------------------|-------------------------------------|---------------|-----------|
| <b>Marking plate, unmarked</b> |               |                    | <b>Single marking tag, unmarked</b> |               |           |
| <b>Size 5 x 8.3 mm</b>         |               | 110 tags per plate | <b>Size 5 x 8.3 mm</b>              |               |           |
| 9075 A/5/10/11                 | Z4.242.5053.0 | 10                 | 9705 A                              | 04.242.0850.0 | 500       |
| <b>Size 5 x 14 mm</b>          |               | 60 tags per plate  | <b>Size 5 x 14 mm</b>               |               |           |
| 9705 AL/5/10/6                 | Z4.242.5153.0 | 10                 | 9705 AL                             | 04.242.1553.0 | 500       |
| <b>Marking plate, unmarked</b> |               |                    | <b>Single marking tag, unmarked</b> |               |           |
| <b>Size 6 x 8.3 mm</b>         |               | 110 tags per plate | <b>Size 5 x 8.3 mm</b>              |               |           |
| 9705 A/6/10/11                 | Z4.242.6053.0 | 10                 | 9705 AB*                            | 04.842.0850.0 | 500       |
| <b>Size 6 x 14 mm</b>          |               | 60 tags per plate  | <b>Size 5 x 14 mm</b>               |               |           |
| 9705 AL/6/10/6                 | Z4.242.6153.0 | 10                 | 9705 ALB                            | 04.842.1553.0 | 500       |
| <b>Marking plate, unmarked</b> |               |                    |                                     |               |           |
| <b>Size 8 x 8.3 mm</b>         |               | 70 tags per plate  |                                     |               |           |
| 9705 A/8/10/7                  | Z4.242.8053.0 | 10                 |                                     |               |           |

**All terminal blocks / 5 mm wide and larger**

**Marking plates**  
for the **marcom** 2 marking computer  
for the **wieplot** 500 plotter system

Type	Part No.	Std. Pack	Type	Part No.	Std. Pack
<b>Marking plate, unmarked</b>			<b>Single marking tag, unmarked</b>		
<b>Size 5 x 8.3 mm</b>		110 tags per plate	<b>Size 5 x 8.3 mm</b>		
9075 A/5/10/11	Z4.242.5053.0	10	9705 A	04.242.0850.0	500
<b>Size 5 x 14 mm</b>		60 tags per plate	<b>Size 5 x 14 mm</b>		
9705 AL/5/10/6	Z4.242.5153.0	10	9705 AL	04.242.1553.0	500
<b>Marking plate, unmarked</b>			<b>Single marking tag, unmarked</b>		
<b>Size 6 x 8.3 mm</b>		110 tags per plate	<b>Size 5 x 8.3 mm</b>		
9705 A/6/10/11	Z4.242.6053.0	10	9705 AB*	04.842.0850.0	500
<b>Size 6 x 14 mm</b>		60 tags per plate	<b>Size 5 x 14 mm</b>		
9705 AL/6/10/6	Z4.242.6153.0	10	9705 ALB	04.842.1553.0	500
<b>Marking plate, unmarked</b>					
<b>Size 8 x 8.3 mm</b>		70 tags per plate			
9705 A/8/10/7	Z4.242.8053.0	10			

\* Custom marking upon request



**2.5 mm<sup>2</sup>/5 mm wide**

**4 mm<sup>2</sup>/6 mm wide**

**10 mm<sup>2</sup>/10 mm wide  
16 mm<sup>2</sup>/12 mm wide  
35 mm<sup>2</sup>/16 mm wide**

Type	Part No.	Std. Pack	Type	Part No.	Std. Pack	Type	Part No.	Std. Pack		
<b>Marking strips, unmarked</b>			<b>Marking strips, unmarked</b>			<b>10 mm<sup>2</sup>/10 mm wide</b>				
9705 A/5/10	04.242.5053.0	25	9705 A/6/10	04.242.6053.0	25	<b>marked for 5 blocks (every 2nd tag) *</b>				
<b>Marking strips, marked</b>			<b>Marking strips, marked</b>			<b>16 mm<sup>2</sup>/12 mm wide</b>				
9705 A/5/9 B	1 - 9	04.842.4953.0	25	9705 A/6/9 B	1 - 9	04.842.5953.0	25	9705 A/5/10/5 B	04.842.5553.0	25
9705 A/5/10 B*		04.842.5053.0	25	9705 A/6/10 B*		04.842.6053.0	25	<b>marked for 5 blocks (every 2nd tag) *</b>		
9705 A/5/10 B	1 - 10	04.845.0153.0	25	9705 A/6/10 B	1 - 10	04.846.0153.0	25	<b>35 mm<sup>2</sup>/16 mm wide</b>		
	11 - 20	04.845.0253.0	25		11 - 20	04.846.0253.0	25	<b>marked for 5 blocks (every 2nd tag) *</b>		
	21 - 30	04.845.0353.0	25		21 - 30	04.846.0353.0	25	9705 A/6/10/5 B		
	31 - 40	04.845.0453.0	25		31 - 40	04.846.0453.0	25	04.842.6553.0		
	41 - 50	04.845.0553.0	25		41 - 50	04.846.0553.0	25	25		
	51 - 60	04.845.0653.0	25		51 - 60	04.846.0653.0	25			
	61 - 70	04.845.0753.0	25		61 - 70	04.846.0753.0	25			
	71 - 80	04.845.0853.0	25		71 - 80	04.846.0853.0	25			
	81 - 90	04.845.0953.0	25		81 - 90	04.846.0953.0	25			
	91 - 100	04.845.1053.0	25		91 - 100	04.846.1053.0	25			
	⊕ (10 x)	04.855.0053.0	25		⊕ (10 x)	04.856.0053.0	25			
	⊖ (10 x)	04.855.0153.0	25		⊖ (10 x)	04.856.0153.0	25			
	+	04.855.0253.0	25		+	04.856.0253.0	25	<b>marked for 5 blocks (every 2nd tag) *</b>		
	-	04.855.0353.0	25		-	04.856.0353.0	25	9705 A/8/10/5 B		
	L1 (10 x)	04.855.0453.0	25		L1 (10 x)	04.856.0453.0	25	04.842.8553.0		
	L2 (10 x)	04.855.0553.0	25		L2 (10 x)	04.856.0553.0	25	25		
	L3 (10 x)	04.855.0653.0	25		L3 (10 x)	04.856.0653.0	25			
	PE (10 x)	04.855.0753.0	25		PE (10 x)	04.856.0753.0	25			
	SL (10 x)	04.855.3153.0	25		SL (10 x)	04.856.3153.0	25			
	N (10 x)	04.855.3253.0	25		N (10 x)	04.856.3253.0	25			
	F1 (10 x)	04.855.0953.0	25		F1 (10 x)	04.856.0953.0	25			
	F2 (10 x)	04.855.1053.0	25		F2 (10 x)	04.856.1053.0	25			
	L1, L2, L3, N, PE (2 x)	04.855.0853.0	25		L1, L2, L3, N, PE (2 x)	04.856.0853.0	25			
with enlarged marking area			with enlarged marking area							
9705 AL/5/10	04.242.5153.0	25	9705 AL/6/10	04.242.6353.0	25					
* Custom marking upon request			* Custom marking upon request			* Specify required marking with part no.				

## Ferrules DIN rail terminal blocks for junction boxes

### Ferrules with insulating material sleeve

**Materials:**

Sleeve: Polypropylene, temperature resistance 105 °C, creepage resistant

Tube: E-Cu, galvanically tin-plated

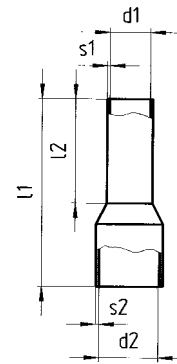

### Ferrules without insulating material sleeve

**Material:**

Tube: E-Cu, galvanically tin-plated

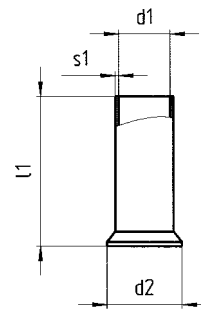

	Cross section mm <sup>2</sup>	Color	Part No.	Std. Pack	
<b>Ferrules with insulating material sleeve</b>	0.50	norm.	white	06.600.2027.0	100
<b>according to DIN 46 228 T4</b>	0.75	norm.	gray	06.600.2127.0	100
	1.00	norm.	red	06.600.2227.0	100
	1.50	norm.	black	06.600.2327.0	100
	1.50	long	black	06.600.2427.0	100
	2.50	norm.	blue	06.600.2527.0	100
	2.50	long	blue	06.600.2627.0	100
	4.00	norm.	gray	06.600.2727.0	100
	4.00	long	gray	06.600.2827.0	100
	6.00	norm.	yellow	06.600.2927.0	100
	6.00	long	yellow	06.600.3027.0	100
	10.00	norm.	red	06.600.3127.0	100
	10.00	long	red	06.600.3227.0	100
	16.00	norm.	blue	06.600.3327.0	100
	16.00	long	blue	06.600.3427.0	100
	25.00	half-long	yellow	06.600.3527.0	50
<b>Ferrules without insulating material sleeve</b>	0.50	norm.		06.600.4027.0	1000
<b>according to DIN 46 228 T1</b>	0.75	norm.		06.600.4127.0	1000
	1.00	norm.		06.600.4227.0	1000
	1.50	norm.		06.600.4327.0	1000
	2.50	norm.		06.600.4427.0	1000
	4.00	norm.		06.600.4527.0	1000
	6.00	norm.		06.600.4627.0	500
	10.00	norm.		06.600.4727.0	500
	16.00	norm.		06.600.4827.0	100
	25.00	norm.		06.600.4927.0	100
	35.00	norm.		06.600.5027.0	100





## Hotline • Advice Additional information

### Technical Support

#### Automation technology:

- Safety technology **safety**  
Phone: +49 951 9324-999  
**e-mail: [safety@wieland-electric.com](mailto:safety@wieland-electric.com)**
- Remote power distribution **podis**®  
Phone: +49 951 9324-998
- **interface**: Power supply, industrial Ethernet switches, timer relays, measuring and monitoring relays, coupling relays, analog modules, remote I/O, surge protection, passive interfaces  
Phone: +49 951 9324-995
- DIN rail terminal blocks **fasis, selos**  
Phone: +49 951 9324-991
- Industrial multipole connectors **revos**  
Phone: +49 951 9324-992
- PCB terminals and connectors **wiecon**  
Appliance terminals, european terminal strips, housings for electronic components  
Phone: +49 951 9324-993

**Fax: +49 951 9326-991**  
**e-mail: [AT.TS@wieland-electric.com](mailto:AT.TS@wieland-electric.com)**

**General information and news:**  
**[www.wieland-electric.com](http://www.wieland-electric.com)**

**Visit our e-catalog at**  
**<http://eshop.wieland-electric.com>**

### Technical Support

#### Building services engineering:

- System connectors for building installation  
**gesis** CON, **gesis** RAN, **gesis** ELECTRONIC  
Phone: +49 951 9324-996
- DIN rail terminal blocks **fasis** BIT, **selos** BIT  
Phone: +49 951 9324-991  
Fax: +49 951 9326-996  
**e-mail: [BIT.TS@wieland-electric.com](mailto:BIT.TS@wieland-electric.com)**

### Technical Support

#### Photovoltaics/solar technology:

- Photovoltaics **gesis** SOLAR  
Phone: +49 951 9324-972  
Fax: +49 951 9326-977  
**e-mail: [Solar@wieland-electric.com](mailto:Solar@wieland-electric.com)**

### Sales Service:

- To contact our sales department regarding availability, delivery schedules, and pricing please call  
Phone: +49 951 9324-990



## Our subsidiaries

... and the addresses of our representations worldwide are available at:

[www.wieland-electric.com](http://www.wieland-electric.com)



### USA

**Wieland Electric Inc.**  
49 International Road  
Burgaw, N.C. 28425  
Phone +1-910-259 5050  
Fax +1-910-259 3691  
sales@wielandinc.com  
www.wielandinc.com



### CANADA

**Wieland Electric Inc.**  
2889 Brighton Road  
Oakville, Ontario L6H 6C9  
Phone +1-905-829 8414  
Fax +1-905-829 8413  
info@wieland-electric.ca  
www.wieland-electric.ca



### GREAT BRITAIN

**Wieland Electric Ltd.**  
Riverside Business Centre,  
Walnut Tree Close  
GB-Guildford /Surrey GU1 4UG  
Phone +44-1483-531 213  
Fax +44-1483-505 029  
sales@wieland.co.uk



### FRANCE

**Wieland Electric SARL.**  
Le Céramê Hall 6  
47, avenue des Genottes  
CS 48313  
95803 Cergy-Pontoise Cedex  
Phone +33-1-30 32 07 07  
Fax +33-1-30 32 07 14  
infos@wieland-electric.fr



### SPAIN

**Wieland Electric S.L.**  
C/ Maria Auxiliadora 2 bajos  
E-08017 Barcelona  
Phone +34-93-252 3820  
Fax +34-93-252 3825  
ventas@wieland.es



### ITALY

**Wieland Electric S.r.l.**  
Via Edison, 209  
I-20019 Settimo Milanese  
Phone +39-02-48 91 63 57  
Fax +39-02-48 92 06 85  
info@wieland-electric.it



### POLAND

**Wieland Electric Sp. Zo.o.**  
Św. Antoniego 8  
62-080 Swadzim  
Phone +48-61-2 22 54 00  
Fax +48-61-8 40 71 66  
office@wieland-electric.pl



### CHINA

**Wieland Electric Trading**  
Unit 2703  
International Soho City  
889 Renmin Rd., Huang Pu District  
PRC- Shanghai 200010  
Phone +86-21-63 555 833  
Fax +86-21-63 550 090  
info-shanghai@wieland-electric.cn



### CZECH REPUBLIC

(Production)  
**Wieland Electric s.r.o.**  
Nadražni 1557  
356 01 Sokolov  
Phone +420-352 302 011  
Fax +420-352 302 027



### DENMARK

**Wieland Electric A/S**  
Vallørækken 26  
DK-4600 Køge  
Phone +45-70-26 66 35  
Fax +45-70-26 66 37  
sales@wieland-electric.dk



◀ Informational material for ordering and for downloading from our websites

Subject to technical modifications!

**gesis**®, **podis**®, **samos**® are registered trademarks of Wieland Electric GmbH



# wieland

Headquarters:

Wieland Electric GmbH  
Brennerstraße 10 – 14  
96052 Bamberg, Germany

Sales and Marketing Center:

Wieland Electric GmbH  
Benzstraße 9  
96052 Bamberg, Germany

Phone +49 951 9324-0

Fax +49 951 9324-198

[www.wieland-electric.com](http://www.wieland-electric.com)

[www.gesis.com](http://www.gesis.com)

[info@wieland-electric.com](mailto:info@wieland-electric.com)

## Industrial technology

### Solutions for the control cabinet

- DIN rail terminal blocks
  - Screw, tension spring or push-in connection technology
  - Wire cross sections up to 240 mm<sup>2</sup>
  - Numerous special functions
  - Software solutions interfacing to CAE systems
- Safety
  - Safe signal acquisition
  - Safety switching devices
  - Modular safety modules
  - Compact safety controllers
  - Applicative consultancy and training
- Network engineering and fieldbus systems
  - Remote maintenance via VPN industrial router and VPN service portal
  - Industrial Ethernet switches
  - PLC and I/O systems, standard and increased environmental conditions
- Interface
  - Power supply units
  - Overvoltage protection
  - Coupling relays, semiconductor switches
  - Timer relays, measuring and monitoring relays
  - Analog coupling and converter modules
  - Passive interfaces

### Solutions for field applications

- Decentralized installation and automation technology
  - Electrical installation for wind tower
  - Fieldbus interfaces and motor starters
- Connectors for industrial applications
  - Rectangular and round connectors
  - Aluminum or plastic housings
  - Degree of protection up to IP68
  - Current-carrying capacity up to 100 A
  - Connectors for hazardous areas
  - Modular, application-specific technology

### PC board terminals and connectors

- Screw or spring clamp connection technology
- Spacings: 3.5 mm to 10.16 mm
- Reflow or wave soldering process

## Building and installation technology

- Building installation systems
  - Main power supply connectors IP 20/IP 65... IP 68
  - Bus connectors
  - Low-voltage connectors
  - Power distribution system with flat cables
  - Distribution systems
  - Bus systems in KNX, LON and radio technology
  - DIN rail terminal blocks for electrical installations
  - Overvoltage protection

contacts  
are  
green.