

Home: Crimp Terminals>

Part Number: 56035-8000

2.00mm Pitch Mi II™ System Wire-to-Wire Crimp Terminal, Reel

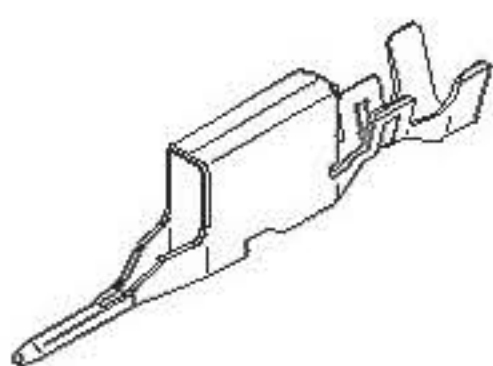

Series Image - Reference only

Status: New Business Not Supported
Replacement: Contact Molex
Series: [56035](#)
Category: Crimp Terminals

Go to [Part Detail](#) ▼

[CHECK DISTRIBUTOR INVENTORY](#)

- [Add to My Parts](#)
- [Email this page](#)

Use With:
[51206](#)

Specifications & Other Documents:

Note - Please disable browser pop-up blockers to view documents on www.molex.com

Product Environmental Compliance

Questions on Product Environmental Compliance? Email productcompliance@molex.com

[EU ELV](#): Not Relevant
[EU RoHS](#): Compliant

[China RoHS](#):
[REACH SVHC](#): Contains SVHC(2015 June 15): No
[Low-Halogen Status](#): Low-Halogen

- [RoHS Certificate of Compliance \(PDF\)](#)
- [Multiple Part Product Compliance Form](#)

Part Detail

[COLLAPSE ALL](#)

▼ **General**

Status	New Business Not Supported
Category	Crimp Terminals
Series	56035
Application	Signal
Obsolete Date	2004/08/01
Product Name	Mi II™
UPC	800753302778

▼ **Physical**

Durability (mating cycles max)	30
Gender	Male
Material - Metal	Phosphor Bronze
Material - Plating Mating	Unplated
Net Weight	80.000/mg
Packaging Type	Reel
Termination Interface: Style	Crimp or Compression
Wire Insulation Diameter	1.20-1.80mm
Wire Size AWG	22, 24, 26
Wire Size mm²	N/A

▼ **Electrical**

(Please review the Product Specification for specific details.)

Current - Maximum per Contact	2.5A
Voltage - Maximum	125V

▼ **Material Info**

▼ **Reference - Drawing Numbers**

Product Specification	PS-51225-003, PS-52484-004
Sales Drawing	SD-56035-002

Application Tooling

[FAQ](#)

Tooling specifications and manuals are found by selecting the products below.

Crimp Height Specifications are then contained in the Application Tooling Specification document.

Japan

Description	Product #
Applicator for M211A Bench Press, 22-26 AWG Wire	57399-3000
Hand Extraction Tool	57399-6000

Crimp Quality Equipment

[Molex also offers wire strippers, pull testers, shut-height gauges, micro-meters and more](#)

Previously Available Application Tooling

[Check our list of old tooling that used to be available for this part](#)

Molex Connectors

- Wire-to-Board
- Board-to-Board
- Wire-to-Wire
- Input/Output (IO)
- FFC/FPC
- Sockets

Other Products

- Optical Solutions
- Antennas
- Industrial Automation
- Membrane Switches
- Copper Flex
- PCB Assemblies
- Woodhead Electrical
- Solid State Lighting
- Application Tooling
- Noise Suppression Sheets

Resources

- Contact Us
- Catalog
- Cross-Reference
- Industries
- Literature
- Product Name

Company Info

- About Us
- California Supply Chains Act
- Careers
- Compliance
- ecocare
- Investors
- Press Room
- Shows & Events
- Supplier Portal

Other Info

- Feedback
- Help
- Legal Disclaimer
- Trademarks
- View Mobile Site
- Privacy Policy
- Sitemap

Stay Connected with Molex:

