

**CONNECTOR
DESIGNATORS
A-F-H-L-S
SELF-LOCKING
ROTATABLE
COUPLING**

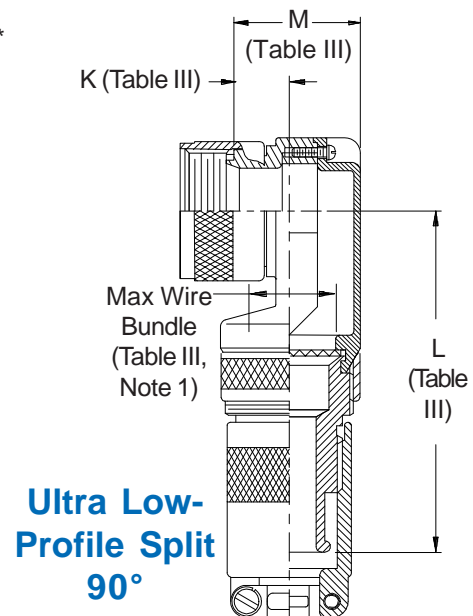

447-427
EMI/RFI Non-Environmental Band-in-a-Can Backshell
 with Cable Clamp Strain-Relief
 Self-Locking Rotatable Coupling - Split Shell

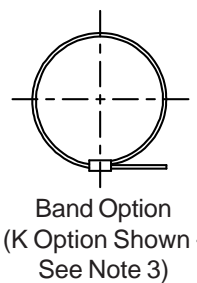
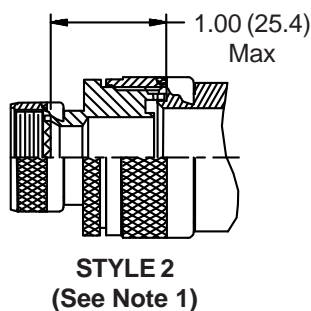
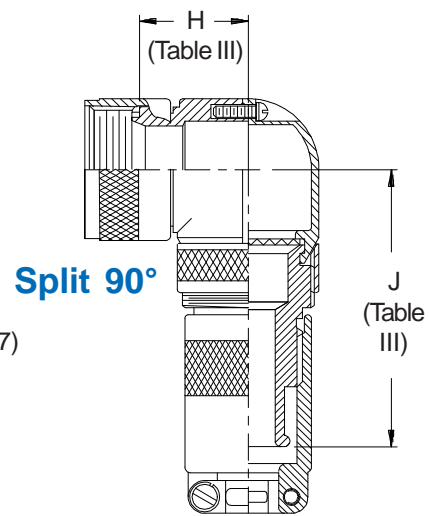
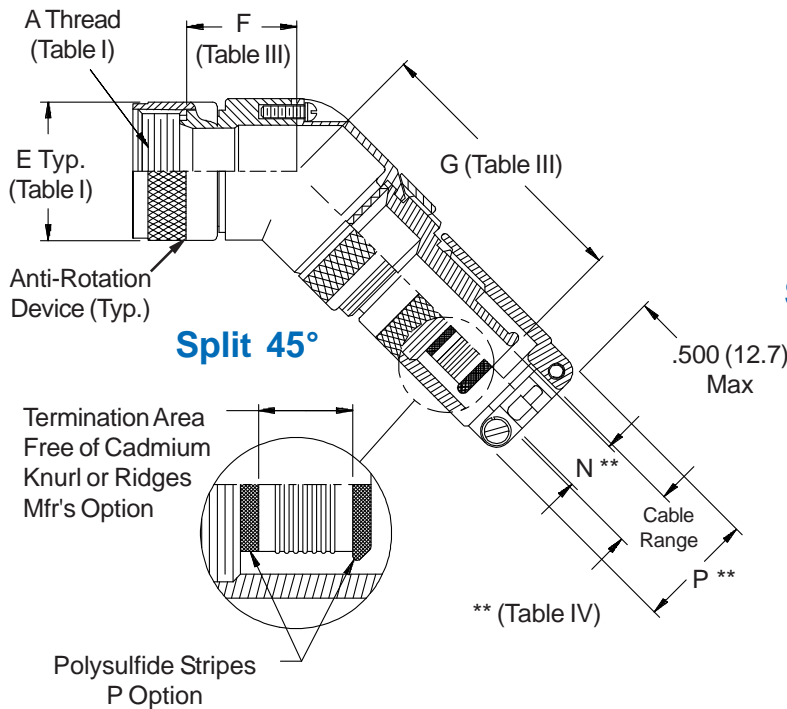
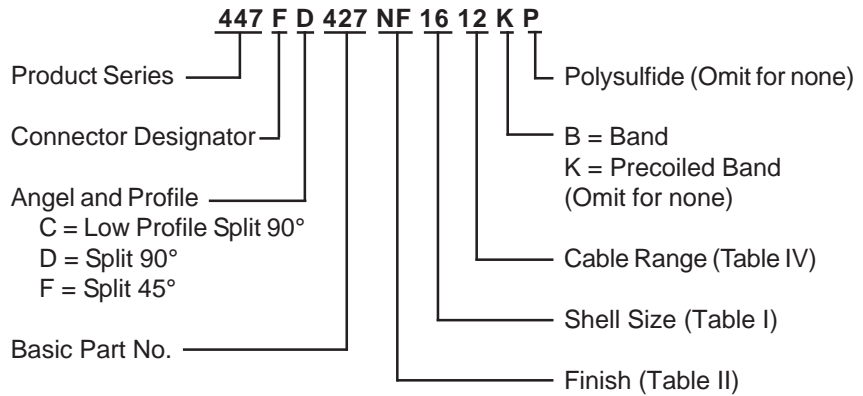

See inside back cover fold-out or pages 13 and 14 for Tables I and II.

TABLE III: ELBOW DIMENSIONS								
Shell Size	F Max	G Max	H Max	J Max	K Ref	L Max	M Max	Function C Max Wire Bundle
08/09	.596 (15.1)	1.840 (46.7)	.836 (21.2)	1.780 (45.2)	.496 (12.6)	2.120 (53.8)	.837 (21.3)	.250 (6.4)
10/11	.656 (16.7)	1.900 (48.3)	.906 (23.0)	1.840 (46.7)	.426 (10.8)	2.280 (57.9)	.887 (22.5)	.375 (9.5)
12/13	.716 (18.2)	1.970 (50.0)	.966 (24.5)	1.910 (48.5)	.426 (10.8)	2.280 (57.9)	.887 (22.5)	.375 (9.5)
14/15	.776 (19.7)	2.000 (50.8)	1.026 (26.1)	1.940 (49.3)	.436 (11.1)	2.350 (59.7)	.987 (25.1)	.500 (12.7)
16/17	.836 (21.2)	2.100 (53.3)	1.086 (27.6)	2.040 (51.8)	.576 (14.6)	2.400 (61.0)	1.137 (28.9)	.625 (15.9)
18/19	.906 (23.0)	2.160 (54.9)	1.156 (29.4)	2.100 (53.3)	.796 (20.2)	2.430 (61.7)	1.337 (34.0)	.625 (15.9)
20/21	.976 (24.8)	2.220 (56.4)	1.216 (30.9)	2.160 (54.9)	.796 (20.2)	2.430 (61.7)	1.337 (34.0)	.625 (15.9)
22/23	1.036 (26.3)	2.280 (57.9)	1.276 (32.4)	2.220 (56.4)	.696 (17.7)	2.580 (65.5)	1.337 (34.0)	.750 (19.1)
24/25	1.096 (27.8)	2.340 (59.4)	1.336 (33.9)	2.280 (57.9)	.696 (17.7)	2.580 (65.5)	1.337 (34.0)	.750 (19.1)

TABLE IV: CABLE RANGE							
Dash No.	N		P		Cable Range		
	±.030	±(.8)	Max		Min	Max	
10	.220	(5.6)	1.000	(25.4)	.130	(3.3)	.250 (6.4)
12	.310	(7.9)	1.250	(31.8)	.250	(6.4)	.380 (9.7)
14	.440	(11.2)	1.340	(34.0)	.310	(7.9)	.440 (11.2)
16	.560	(14.2)	1.470	(37.3)	.375	(9.5)	.630 (16.0)
18	.630	(16.0)	1.560	(39.6)	.560	(14.2)	.690 (17.5)
20	.750	(19.1)	1.620	(41.1)	.630	(16.0)	.750 (19.1)
22	.880	(22.4)	1.750	(44.5)	.750	(19.1)	.880 (22.4)
24	1.000	(25.4)	1.870	(47.5)	.880	(22.4)	1.000 (25.4)
28	1.060	(26.9)	1.970	(50.0)	1.000	(25.4)	1.130 (28.7)
32	1.190	(30.2)	2.090	(53.1)	1.130	(28.7)	1.250 (31.8)

1. When maximum cable entry (page 21) is exceeded, Style 2 will be supplied. Dimensions F, G, H, and J will not apply. Please consult factory.
2. Metric dimensions (mm) are indicated in parentheses.
3. Backshells supplied with 600-052-* band, see Glenair Series 600 Tool Catalog for installation.
4. Angular function "C", low-profile split elbow, not available with "S" connector designator.