

CONNECTOR DESIGNATORS
A-B*-C-D-E-F
G-H-J-K-L-S
 * Conn. Desig. B See Note 3
DIRECT COUPLING

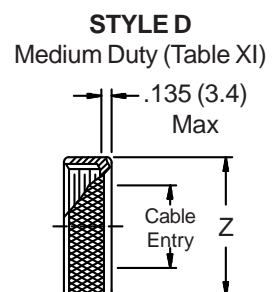

443-010
EMI/RFI Cable Sealing Backshell
Band-in-a-Can with Strain-Relief
Direct Coupling - Full Radius Profile

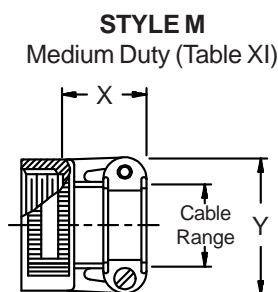
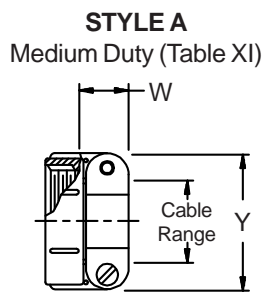
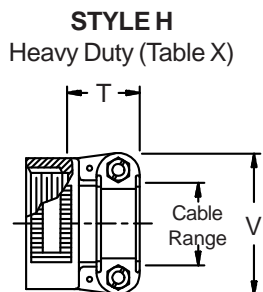
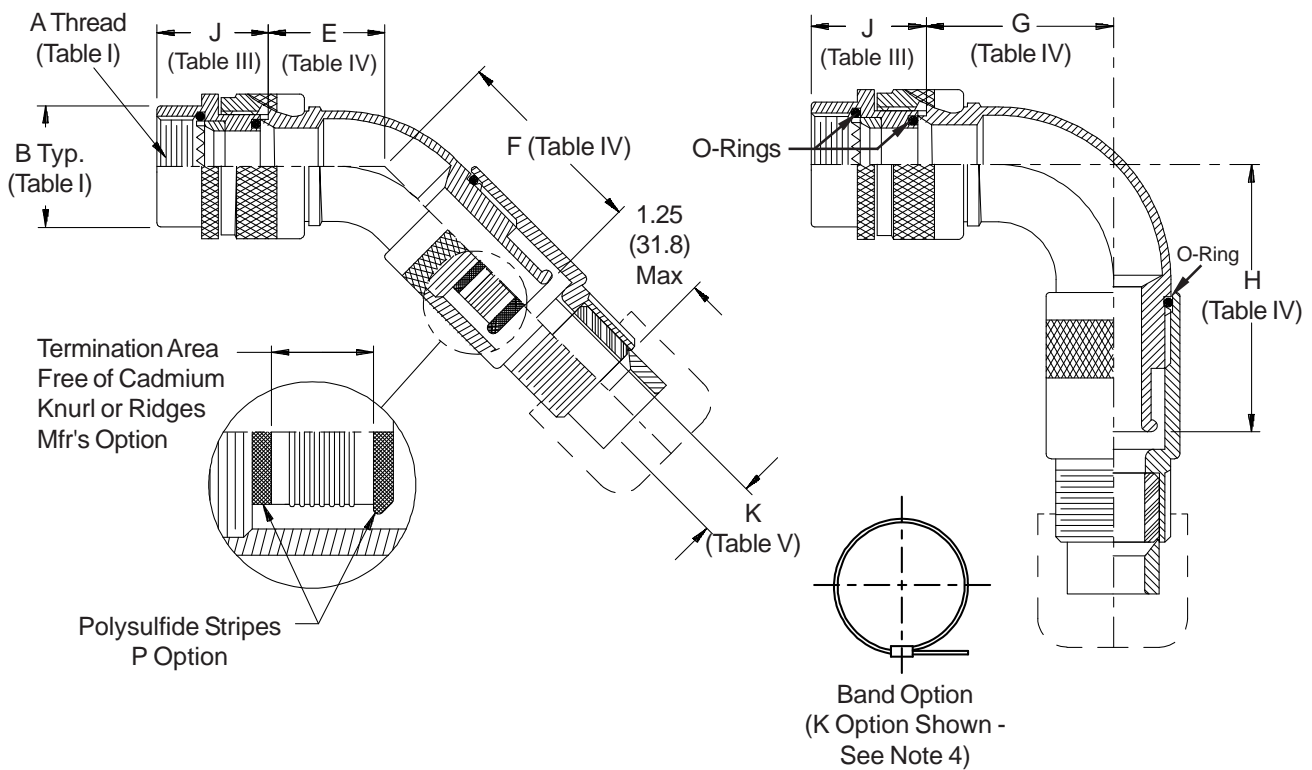
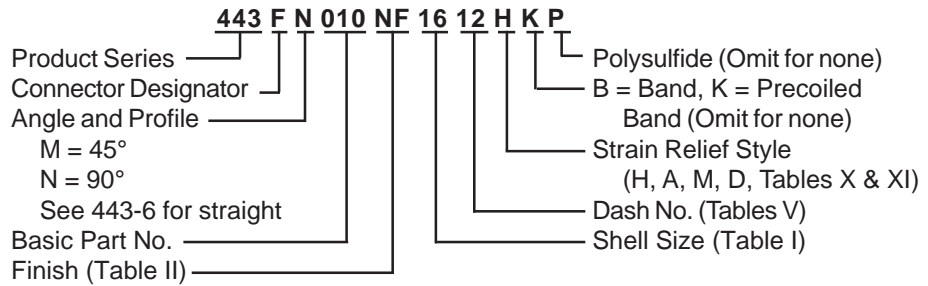

TABLE III: FRONT ADAPTER

Shell Size	J Max - Conn. Designator		
	A-E-F		
	J-H-L-S	D-B-G-K	C
08/09	1.180 (30.0)	1.250 (31.8)	
10/11	1.180 (30.0)	1.250 (31.8)	
12/13	1.180 (30.0)	1.250 (31.8)	1.735 (44.1)
14/15	1.180 (30.0)	1.250 (31.8)	1.915 (48.6)
16/17	1.380 (35.0)	1.560 (39.6)	1.915 (48.6)
18/19	1.380 (35.0)	1.560 (39.6)	1.915 (48.6)
20/21	1.380 (35.0)	1.560 (39.6)	1.915 (48.6)
22/23	1.380 (35.0)	1.560 (39.6)	1.915 (48.6)
24/25	1.380 (35.0)	1.560 (39.6)	1.915 (48.6)
28/29	1.610 (40.9)	1.560 (39.6)	1.915 (48.6)
32/33	1.610 (40.9)	1.750 (44.5)	1.915 (48.6)
36	1.610 (40.9)	1.750 (44.5)	1.915 (48.6)
40	1.610 (40.9)	2.190 (55.6)	1.915 (48.6)

TABLE IV: ELBOW DIMENSIONS

Elbow Size	E Max	F Max	G Max	H Max
04	.875 (22.2)	1.100 (27.9)	1.250 (31.8)	1.505 (38.2)
06	.938 (23.8)	1.160 (29.5)	1.375 (34.9)	1.625 (41.3)
08	.938 (23.8)	1.160 (29.5)	1.375 (34.9)	1.625 (41.3)
10	1.062 (27.0)	1.290 (32.8)	1.625 (41.3)	1.875 (47.6)
12	1.094 (27.8)	1.350 (34.3)	1.750 (44.5)	1.995 (50.7)
16	1.156 (29.4)	1.410 (35.8)	1.875 (47.6)	2.125 (54.0)
20	1.570 (39.9)	1.820 (46.2)	2.765 (70.2)	2.500 (63.5)
24	1.570 (39.9)	1.820 (46.2)	2.765 (70.2)	2.500 (63.5)
28	1.820 (46.2)	2.070 (52.6)	3.225 (81.9)	2.620 (66.5)

See inside
back cover fold-out or
pages 13 and 14
for Tables I and II.

1. Metric dimensions (mm) are indicated in parentheses.
2. Cable range is defined as the accommodations range for the wire bundle or cable. Dimensions shown are not intended for inspection criteria.
3. When using Connector Designator B refer to pages 18 and 19 for part number development.
4. Backshells supplied with 600-052-* band, see Glenair Series 600 Tool Catalog for installation.

TABLE V: CABLE ENTRY

Dash No.	Clamp Size	K Dia
05	04	.312 (7.9)
06	06	.375 (9.5)
07	06	.438 (11.1)
08	08	.500 (12.7)
09	10	.562 (14.3)
10	10	.625 (15.9)
11	12	.688 (17.5)
12	12	.750 (19.1)
13	16	.812 (20.6)
14	16	.875 (22.2)
15	16	.938 (23.8)
16	20	1.000 (25.4)
17	20	1.062 (27.0)
18	20	1.125 (28.6)
20	20	1.250 (31.8)
22	24	1.375 (34.9)
24	28	1.500 (38.1)

TABLE X: CABLE ENTRY

Clamp Size	T Max	V Max	Cable Range			
			Min		Max	
			04	.780 (19.8)	.957 (24.3)	.125 (3.2)
06	.780 (19.8)	1.145 (29.1)	.250 (6.4)	.437 (11.1)		
08	.780 (19.8)	1.332 (33.8)	.387 (9.8)	.562 (14.3)		
10	.780 (19.8)	1.332 (33.8)	.350 (8.9)	.625 (15.9)		
12	.811 (20.6)	1.551 (39.4)	.500 (12.7)	.750 (19.1)		
16	.905 (23.0)	1.770 (45.0)	.625 (15.9)	.937 (23.8)		
20	1.092 (27.7)	2.113 (53.7)	.875 (22.2)	1.250 (31.8)		
24	1.124 (28.5)	2.363 (60.0)	1.000 (25.4)	1.375 (34.9)		
28	1.399 (35.5)	2.770 (70.4)	1.250 (31.8)	1.625 (41.3)		

TABLE XI: CABLE ENTRY

Clamp Size	W Max	X Max	Y Max	Z Max	Cable Range	
					Min **	Max
					03*	.437 (11.1)
04*	.437 (11.1)	.760 (19.3)	.906 (23.0)	.755 (19.2)	.188 (4.8)	.312 (7.9)
06*	.500 (12.7)	.760 (19.3)	1.093 (27.8)	.942 (23.9)	.281 (7.1)	.438 (11.1)
08	.563 (14.3)	.760 (19.3)	1.187 (30.1)	1.067 (27.1)	.387 (9.8)	.562 (14.3)
10	.563 (14.3)	.760 (19.3)	1.281 (32.5)	1.192 (30.3)	.375 (9.5)	.625 (15.9)
12	.563 (14.3)	.760 (19.3)	1.500 (38.1)	1.380 (35.1)	.438 (11.1)	.750 (19.1)
16	.656 (16.7)	1.073 (27.3)	1.719 (43.7)	1.535 (39.0)	.625 (15.9)	.938 (23.8)
20	.656 (16.7)	1.323 (33.6)	2.062 (52.4)	1.848 (46.9)	.875 (22.2)	1.250 (31.8)
24	.656 (16.7)	1.323 (33.6)	2.312 (58.7)	2.255 (57.3)	1.000 (25.4)	1.375 (34.9)
28	1.188 (30.2)	1.572 (39.9)	2.719 (69.1)	2.505 (63.6)	1.250 (31.8)	1.625 (41.3)

* Not available in Style M clamp. ** Not Applicable Style D