

CONNECTOR DESIGNATORS
A-F-H-L-S
SELF-LOCKING
ROTATABLE
COUPLING

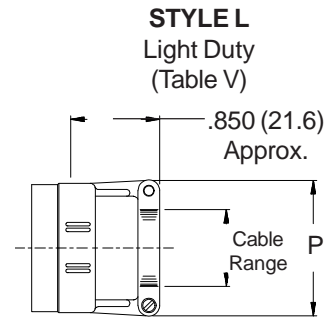
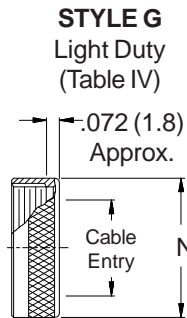
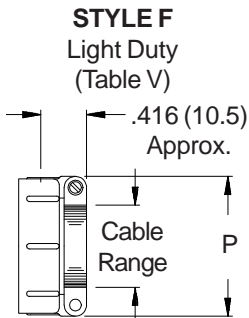
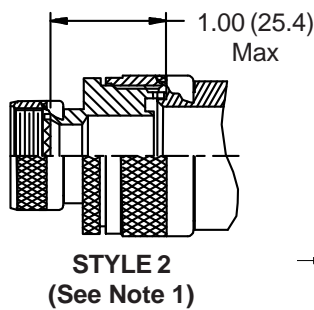
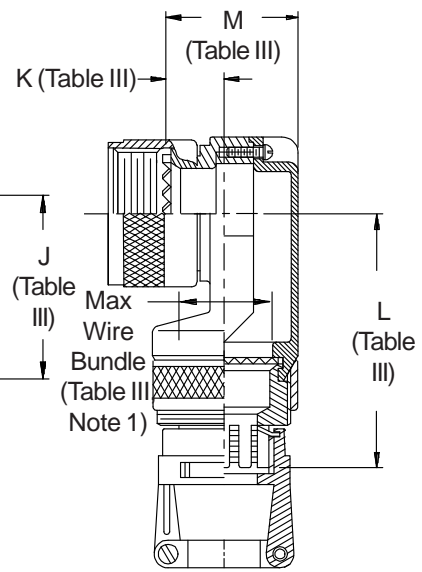
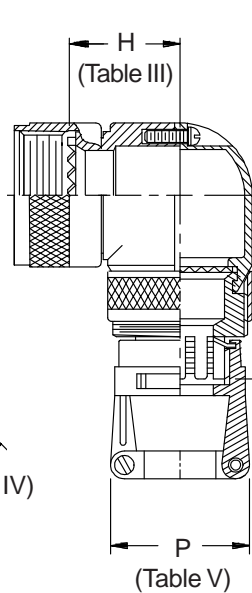
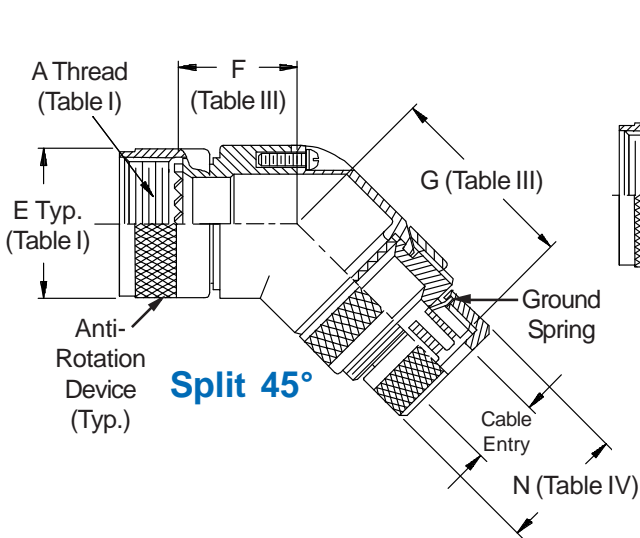
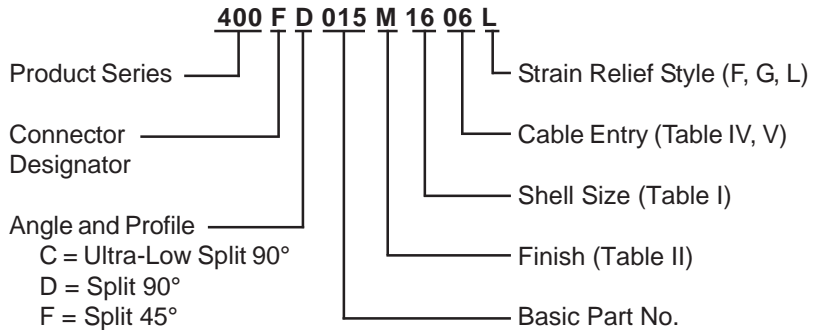

**See inside back cover
fold-out or pages 13 and
14 for Tables I and II.**

TABLE III: DIMENSIONS

Shell Size	F Max	G Max	H Max	J Max	K Ref	L Max	M Max	Function C Max Wire Bundle
08/09	.596 (15.1)	1.500 (38.1)	.836 (21.2)	1.440 (36.6)	.496 (12.6)	2.060 (52.3)	.837 (21.3)	.250 (6.4)
10/11	.656 (16.7)	1.560 (39.6)	.906 (23.0)	1.500 (38.1)	.426 (10.8)	2.220 (56.4)	.887 (22.5)	.375 (9.5)
12/13	.716 (18.2)	1.630 (41.4)	.966 (24.5)	1.570 (39.9)	.426 (10.8)	2.220 (56.4)	.887 (22.5)	.375 (9.5)
14/15	.776 (19.7)	1.660 (42.2)	1.026 (26.1)	1.600 (40.6)	.436 (11.1)	2.290 (58.2)	.987 (25.1)	.500 (12.7)
16/17	.836 (21.2)	1.760 (44.7)	1.086 (27.6)	1.700 (43.2)	.576 (14.6)	2.340 (59.4)	1.137 (28.9)	.625 (15.9)
18/19	.906 (23.0)	1.820 (46.2)	1.156 (29.4)	1.760 (44.7)	.796 (20.2)	2.370 (60.2)	1.337 (34.0)	.625 (15.9)
20/21	.976 (24.8)	1.880 (47.8)	1.216 (30.9)	1.820 (46.2)	.796 (20.2)	2.370 (60.2)	1.337 (34.0)	.625 (15.9)
22/23	1.036 (26.3)	1.940 (49.3)	1.276 (32.4)	1.880 (47.8)	.696 (17.7)	2.520 (64.0)	1.337 (34.0)	.750 (19.1)
24/25	1.096 (27.8)	2.000 (50.8)	1.336 (33.9)	1.940 (49.3)	.696 (17.7)	2.520 (64.0)	1.337 (34.0)	.750 (19.1)

TABLE IV: CABLE ENTRY

Dash No.	N Max	Cable Entry Max
02	.545 (13.8)	.250 (6.4)
03	.670 (17.0)	.375 (9.5)
04	.795 (20.2)	.500 (12.7)
05	.920 (23.4)	.625 (15.9)
06	1.045 (26.5)	.750 (19.1)
07	1.170 (29.7)	.875 (22.2)
08	1.295 (32.9)	1.000 (25.4)
09	1.420 (36.1)	1.125 (28.6)
10	1.670 (42.4)	1.250 (31.8)

TABLE V: CABLE ENTRY

Dash No.	P Max	Cable Range	
		Min	Max
02	.968 (24.6)	.125 (3.2)	.250 (6.4)
03	1.046 (26.6)	.250 (6.4)	.375 (9.5)
04	1.156 (29.4)	.250 (6.4)	.500 (12.7)
05	1.218 (30.9)	.375 (9.5)	.625 (15.9)
06	1.343 (34.1)	.500 (12.7)	.750 (19.1)
07	1.468 (37.3)	.625 (15.9)	.875 (22.2)
08	1.593 (40.5)	.625 (15.9)	1.000 (25.4)
09	1.718 (43.6)	.750 (19.1)	1.125 (28.6)
10	1.843 (46.8)	.875 (22.2)	1.250 (31.8)

1. When maximum cable entry (page 21) is exceeded, Style 2 will be supplied (not available in Function C). Dimensions F, G, H and J will not apply. Please consult factory.
2. Metric dimensions (mm) are indicated in parentheses.
3. Cable range is defined as the accommodations range for the wire bundle or cable. Dimensions shown are not intended for inspection criteria.
4. Angular function "C", low-profile split elbow, not available with "S" connector designator.