

Enclosed Cord and Plug Series

3PN Series

The cased plug-in models feature a ventilated steel case, input line cord and plug, fused NEMA rated output receptacle, and an illuminated on/off switch. They are connected for output voltage increase with a clockwise rotation, and the dials are graduated from 0-100% of the voltage setting.

For application flexibility, two field modification kits have been added. The 3PN-MK kit allows either the 3PN221B or

3PN501B to be wall, bench top, or machine mounted. The 3PN-SK kit provides an adjustable voltage stop for either the 3PN1000, 3PN1200, or 3PN1500 series.

Cased plug-in models are also available with a pivot and jewel AC voltmeter or ammeter (with $\pm 5\%$ full scale accuracy) conveniently located atop the enclosure for easy readout.

VOLTS	PART NO.	INPUT		OUTPUT				SCHEMATIC (Pg. 8 & 9)	NET WT LBS
		HERTZ	VOLTS	CONSTANT CURRENT LOAD		CONSTANT IMPEDANCE LOAD			
				MAX AMPS	MAX KVA	MAX AMPS	MAX KVA		
120	3PN221B	60	0-132	2.50	0.33	—	—	3	3
	3PN501B	50/60	0-140	5.0 †	0.70	—	—	3	7 3/4
	3PN1010B	50/60	0-140	10 †	1.4	—	—	3	10 1/4
	3PN1010BA 3PN1010BV	50/60	0-140	10 †	1.4	w/Ammeter w/Voltmeter		9	10 1/4
	3PN1210B	60	0-120	12 †	1.44	15	1.80	11	10 1/4
	3PN1510B	50/60	0-140	15 †	2.10	—	—	3	18
	3PN1510BA 3PN1510BV	50/60	0-140	15 †	2.10	w/Ammeter w/Voltmeter		9	18
	3PN2210B	50/60	0-140	22 †	3.08	—	—	3	24 1/4
240	3PN1020B	50/60	0-280	3.5 †	0.98	—	—	3	10 1/4
	3PN1020BA 3PN1020BV	50/60	0-280	3.5 †	0.98	w/Ammeter w/Voltmeter		9	10 1/4
	3PN1220B	60	0-240	5.0 †	1.20	7.0	1.68	11	10 1/4
	3PN1520B	50/60	0-280	9.5 †	2.66	—	—	3	22
	3PN2520B	50/60	0-280	10 †	2.80	—	—	3	24 1/4

† Unit is fused for the constant current rating at the factory.



3PN221B,
3PN501B



3PN-MK-Kit



3PN1010B



3PN-SK-Kit

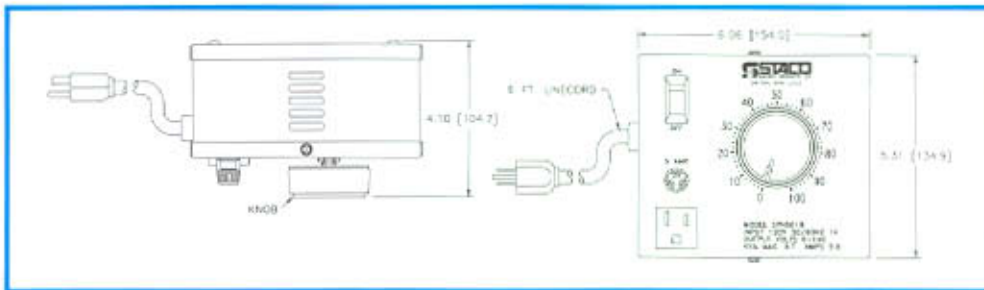

3PN221B, 3PN501B

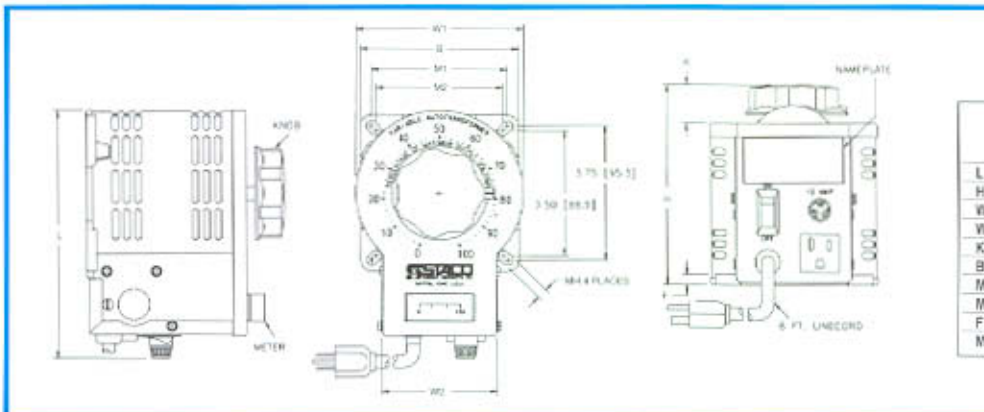

3PN1010BV & 3PNJ201BV, A Cord and Plug

	3PN1000B 3PN1200B 3PN1500B Series	3PN1500B 3PNJ401B Series	3PN2210B 3PN2520B
L	6.98" (176.8 mm)	9.35" (237.4 mm)	10.85" (275.6 mm)
H	5.50" (139.7 mm)	6.00" (152.4 mm)	6.31" (160.3 mm)
W1	4.62" (117.4 mm)	6.24" (158.4 mm)	7.95" (202.1 mm)
W2	3.18" (80.8 mm)	4.31" (109.6 mm)	4.31" (109.6 mm)
K	1.06" (27.0 mm)	1.00" (25.4 mm)	1.85" (47.0 mm)
B	4.38" (111.1 mm)	5.50" (139.7 mm)	7.13" (181.0 mm)
M1	3.75" (95.3 mm)	4.75" (120.7 mm)	6.38" (161.9 mm)
M2	3.50" (88.9 mm)	—	5.88" (149.2 mm)
F	0.28" (7.1 mm)	0.32" (8.1 mm)	0.32" (8.1 mm)
NH	0.29" (7.4 mm)	0.31" (7.9 mm)	0.36" (9.1 mm)

Enclosed Cord and Plug Series



3PN1510B



3PN2210B



3PN1010BV

L Series

These fully enclosed variable voltage controls provide protection from physical abuse, chemical spills, and other hazards. They are ideal for about every laboratory application including control of electric heating elements, lighting, electric motor speed or power, and electrical testing. Output voltage is controlled with a large slip resistant knob which increases the voltage linearly as it is turned clockwise.

In addition to portable use, the rugged, flat-topped enclosure has a slot at top rear for wall mounting. All models include line cord and plug, receptacle, switch, pilot lamp and fuse (the metered unit includes a circuit breaker). A voltmeter and ammeter are included in the L1010VA. The meter accuracy is $\pm 3\%$, and a meter range selector is used to increase reading resolution.

MODEL NUMBER*	LINE VOLTAGE	OUTPUT		DIMENSIONS			WEIGHT (LBS.)
		VOLTAGE	CURRENT	HEIGHT	WIDTH	DEPTH	
L221	120	0-132	1.75	6.31" [160.4]	5.00" [127.0]	4.25" [108.0]	3.5
L501			4.5	7.75" [197.0]	5.38" [136.5]	5.62" [142.9]	7.25
L1010		0-140	10.0	9.41" [238.9]	6.50" [165.1]	6.25" [158.8]	12.25
L1010VA		10.0	12.38" [314.3]	10.75" [273.0]	6.25" [158.8]	17.75	

* All models 50/60 Hz operation except L221, which is 60 Hz only.



3PN 120-VOLT TYPES
3PN (120)



3PN 240-VOLT TYPES
3PN (240)

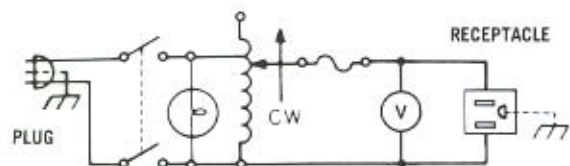

Schematics and Wiring Diagrams

General Wiring Information

Common is used as the third leg in a three phase open delta or as neutral in a three wire single phase series and four wire, three phase wye connection. It is not used in two wire series or three wire wye connection.

If ganged units are used in a system that ordinarily has a common neutral or ground between source and load, the neutral or ground must be connected to the common terminals of the variable transformer assembly. If the system has no neutral, the load must be balanced or the transformers will be damaged.

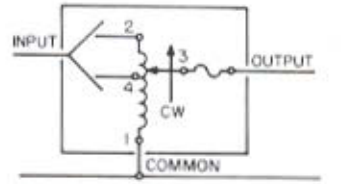

FUSE RECOMMENDED BUT NOT SUPPLIED

1

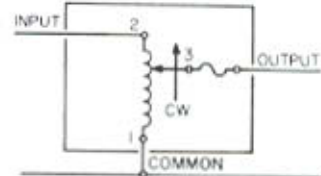

FUSE RECOMMENDED BUT NOT SUPPLIED

2

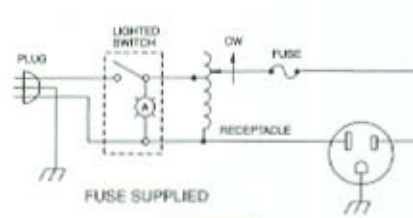

FUSE SUPPLIED

3

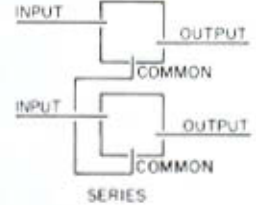

SERIES

4

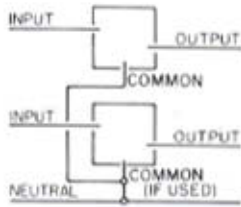

THREE PHASE OPEN DELTA

5

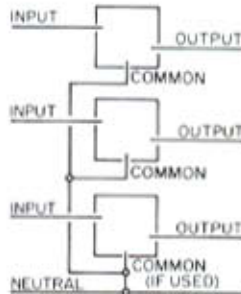

THREE PHASE WYE

6

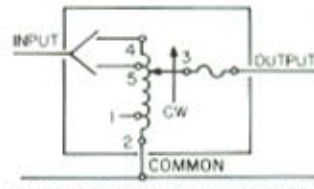

FUSE RECOMMENDED BUT NOT SUPPLIED.

7

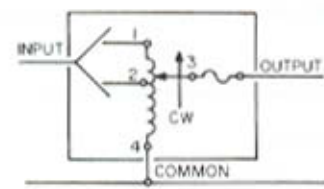

FUSE RECOMMENDED BUT NOT SUPPLIED

8

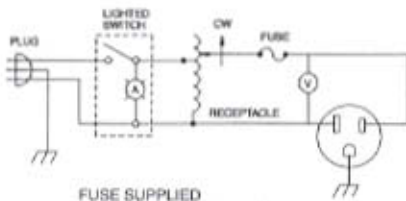

FUSE SUPPLIED

9

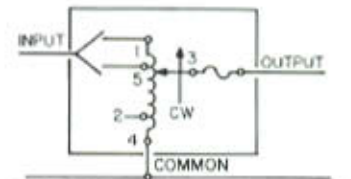

FUSE RECOMMENDED BUT NOT SUPPLIED.

10

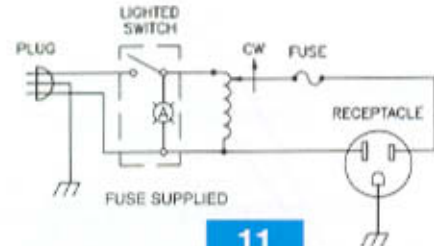

FUSE SUPPLIED

11

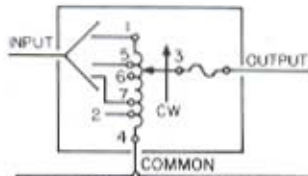

FUSE RECOMMENDED BUT NOT SUPPLIED.

12

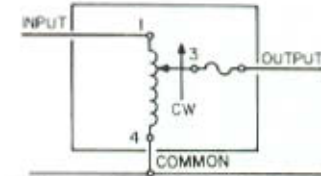

FUSE RECOMMENDED BUT NOT SUPPLIED.

13

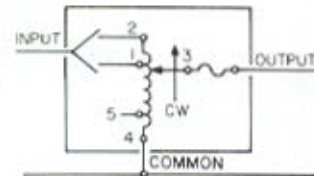

FUSE RECOMMENDED BUT NOT SUPPLIED.

14

Schematics and Wiring Diagrams

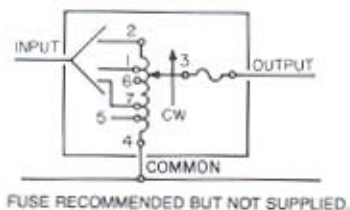

15

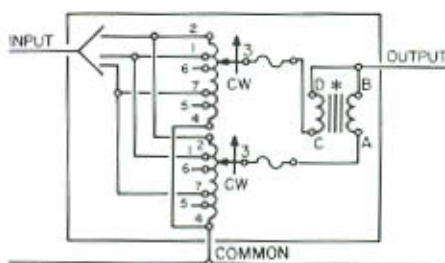

* PARALLELING CHOKE FOR 2510-51LAC
 * PARALLELING CHOKE FOR 2520-52LAC
 TERMINALS #6 AND #7 OMITTED ON 2510
 FUSE RECOMMENDED BUT NOT SUPPLIED.

16

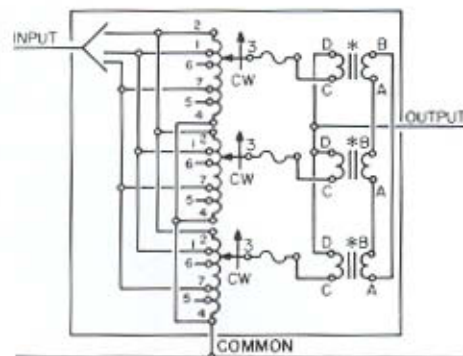

* PARALLELING CHOKE FOR 2510-51LAC
 * PARALLELING CHOKE FOR 2520-52LAC
 TERMINALS #6 AND #7 OMITTED ON 2510
 FUSE RECOMMENDED BUT NOT SUPPLIED.

17

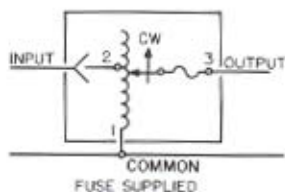

18

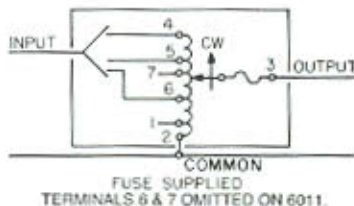

19

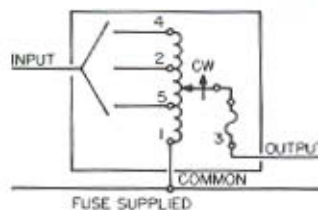

Terminals 4 and 5 omitted on 5011 Series
 Terminal 5 omitted on 6011 Series

20

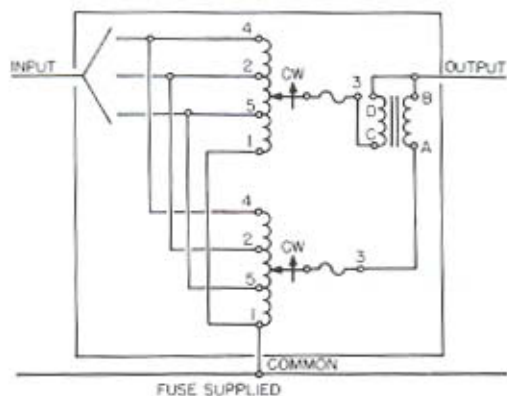

Terminals 4 and 5 omitted on 5011 Series
 Terminal 5 omitted on 6011 Series

21

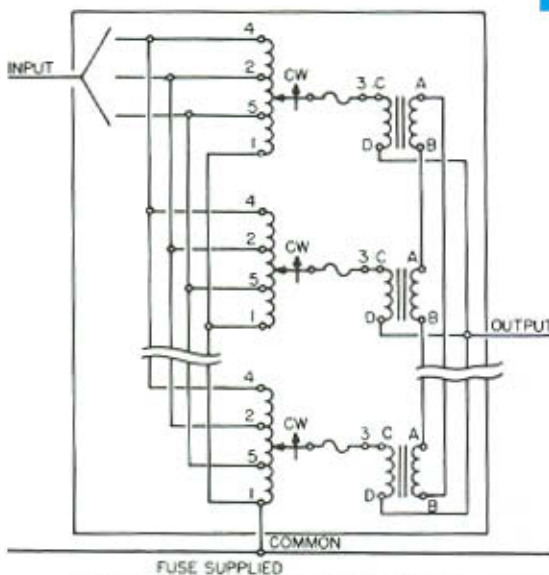

Terminals 4 and 5 omitted on 5011 Series
 Terminal 5 omitted on 6011 Series

22

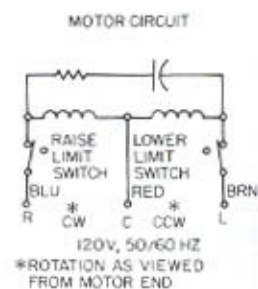

23