



8.00mm (.315") Pitch Beau Eurostyle® Terminal Strip

39150 Two Screw, Terminal Strip



C15 Series

FEATURES AND SPECIFICATIONS

Features and Benefits

- Modular design can be cut into smaller sections
- Dead front construction
- Captive wire protectors (option)

Electrical

Voltage: 300V
Maximum Current: 10 Amp
Insulation Resistance: >3 x 10⁶ Megaohms

Mechanical

Rec. Tightening Torque: 4 in.-lbs., .45 Nm
Operating Temperature: 105°C

Physical

Housing: Nylon 6.6, UL94 V-2, white
Contacts: Brass, chemically tinned
Wire Protector: 18/18 stainless band steel
Screws: Steel
Screw Plating: Zinc
Terminals: Brass
Terminal Plating: Nickel
Wire Range: 12 to 18 AWG, 2.5 to 0.75mm²

Reference Information

UL : File No. E82573
Guide No. XCFR2
CSA: File No. 025562

CATALOG DRAWING (FOR REFERENCE ONLY)

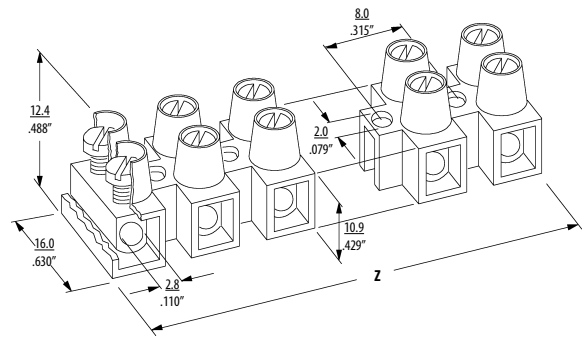
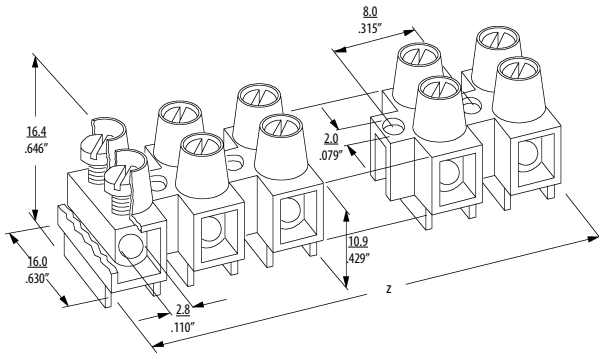

ORDERING INFORMATION AND DIMENSIONS

Part Numbers - With Standoffs				# of Circuits	Dimensions Z	
No Wire Protector		Wire Protector			in	mm
Order #	Engineering #	Order #	Engineering #			
39150-0102	C1502	39150-0302	C1502-151	2	.54	13.8
39150-0103	C1503	39150-0303	C1503-151	3	.86	21.8
39150-0104	C1504	39150-0304	C1504-151	4	1.17	29.8
39150-0105	C1505	39150-0305	C1505-151	5	1.49	37.8
39150-0106	C1506	39150-0306	C1506-151	6	1.80	45.8
39150-0107	C1507	39150-0307	C1507-151	7	2.12	53.8
39150-0108	C1508	39150-0308	C1508-151	8	2.43	61.8
39150-0109	C1509	39150-0309	C1509-151	9	2.75	69.8
39150-0110	C1510	39150-0310	C1510-151	10	3.06	77.8
39150-0111	C1511	39150-0311	C1511-151	11	3.38	85.8
39150-0112	C1512	39150-0312	C1512-151	12	3.69	93.8

Part Numbers - Low Profile				# of Circuits	Dimensions Z	
No Wire Protector		Wire Protector			in	mm
Order #	Engineering #	Order #	Engineering #			
39150-0202	C1502-L	39150-0402	C1502-L-151	2	.54	13.8
39150-0203	C1503-L	39150-0403	C1503-L-151	3	.86	21.8
39150-0204	C1504-L	39150-0404	C1504-L-151	4	1.17	29.8
39150-0205	C1505-L	39150-0405	C1505-L-151	5	1.49	37.8
39150-0206	C1506-L	39150-0406	C1506-L-151	6	1.80	45.8
39150-0207	C1507-L	39150-0407	C1507-L-151	7	2.12	53.8
39150-0208	C1508-L	39150-0408	C1508-L-151	8	2.43	61.8
39150-0209	C1509-L	39150-0409	C1509-L-151	9	2.75	69.8
39150-0210	C1510-L	39150-0410	C1510-L-151	10	3.06	77.8
39150-0211	C1511-L	39150-0411	C1511-L-151	11	3.38	85.8
39150-0212	C1512-L	39150-0412	C1512-L-151	12	3.69	93.8

Molex Industrial Division
New England Operations
Gilford, NH 03249-6600
Phone (603) 524-5101
Fax (603) 524-1627