

**CONNECTOR DESIGNATORS**  
**A-F-H-L-S**

**ROTATABLE COUPLING**

**TYPE E INDIVIDUAL AND/OR OVERALL SHIELD TERMINATION**

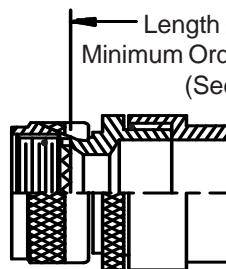
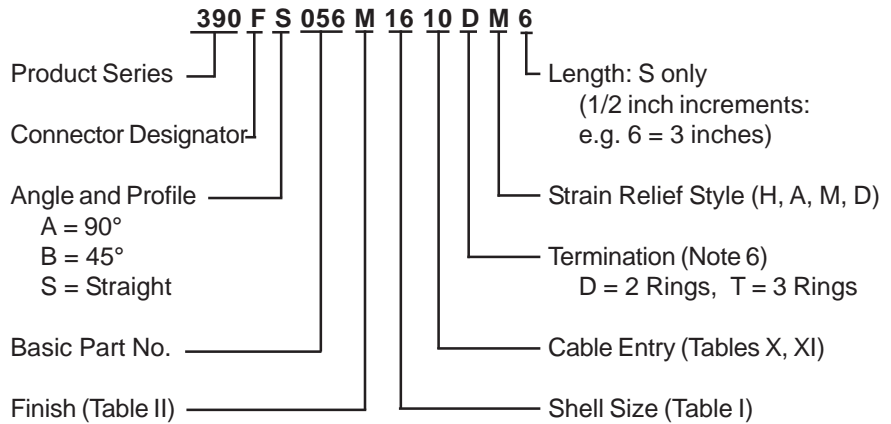

**STYLE 2 (STRAIGHT)**  
 See Note 1)

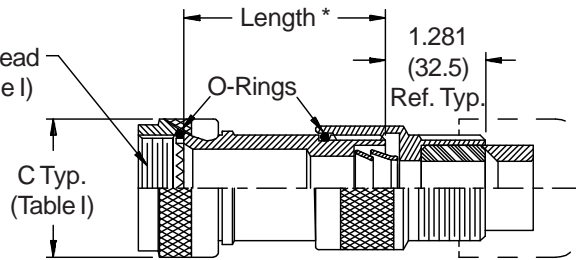

\* Length  $\pm .060$  (1.52)  
 Minimum Order Length 1.5 Inch (See Note 4)

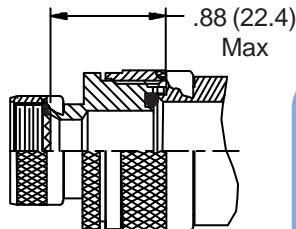

**STYLE 2 (45° & 90°)**  
 See Note 1)

**-445** Now Available with the "NESTOR"  
**Glenair's Non-Detent, Spring-Loaded, Self-Locking Coupling.**  
 Add "-445" to Specify This AS85049 Style "N" Coupling Interface.

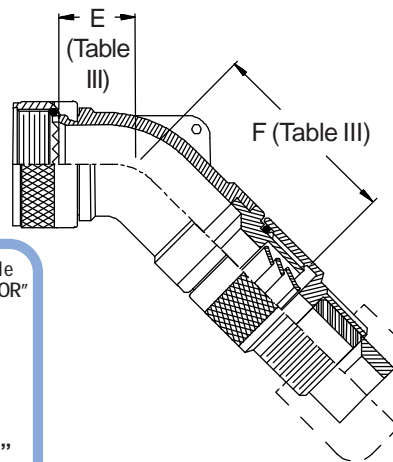

**STYLE A**  
 Medium Duty (Table XI)

**STYLE M**  
 Medium Duty (Table XI)

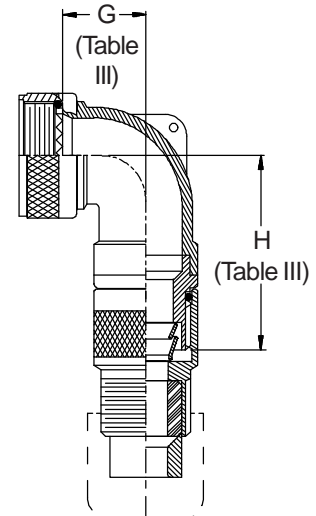

**STYLE D**  
 Medium Duty (Table XI)

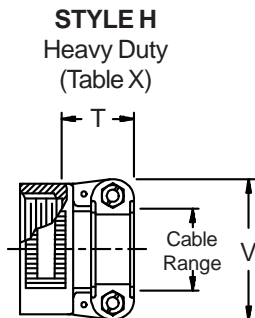

**STYLE H**  
 Heavy Duty (Table X)

