

**CONNECTOR
 DESIGNATORS
 A-F-H-L-S
 SELF-LOCKING
 ROTATABLE
 COUPLING**

**TYPE E INDIVIDUAL
 AND/OR OVERALL
 SHIELD TERMINATION**

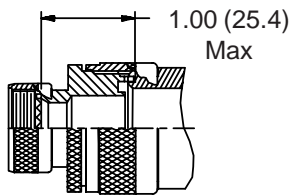

STYLE 2
 (See Note 1)

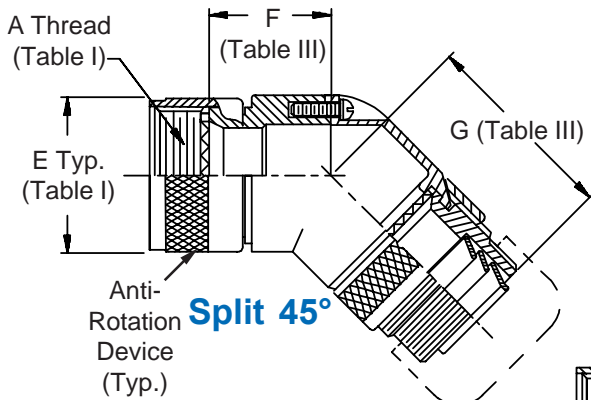
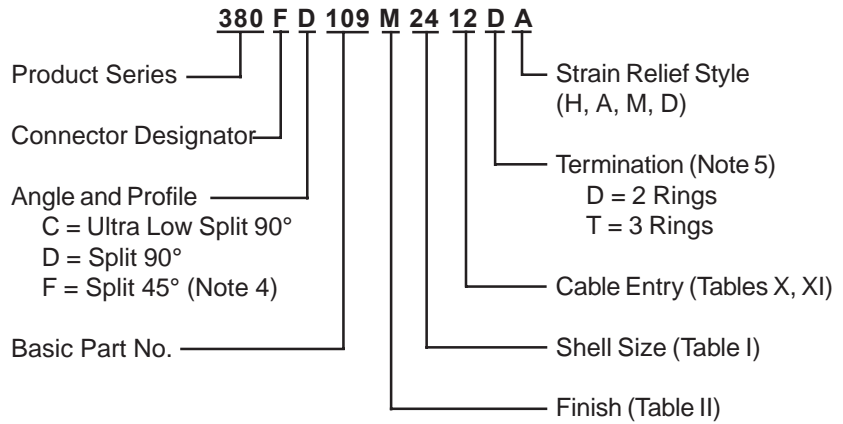